

Controller



Controller

PMEC/AMEC
PSEP/ASEP/DSEP
MSEP
ERC3
ERC2
PCON-CA/CFA
PCON
ACON

PCON/ACON-ABU
SCON-CA
MSCON
PSEL
ASEL
SSEL
XSEL
PS-24



PMEC/AMEC



PSEP/ASEP/DSEP



MSEP



ERC3



ERC2



PCON-CA



ACON



PCON-ABU
ACON-ABU



SCON-CA



MSCON



PSEL



ASEL



SSEL



XSEL



PS241/PS242

Controller

PMEC	3 Position Controller for RCP3/RCP2	PMEC-C	537
AMEC	3 Position Controller for RCA2/RCA/RCL	AMEC-C	
PSEP	3 Position Controller for RCP3/RCP2	PSEP-C / CW	547
ASEP	3 Position Controller for RCA2/RCA/RCL	ASEP-C / CW	
DSEP	3 Position Controller for RCD	DSEP-C / CW	
MSEP	Position Controller for RCP4/RCP3/RCP2/RCA2/RCA/RCL, 8-axis type	MSEP-C	563
ERC3	ERC3 Controller	ERC3	577
ERC2	ERC2 Controller	ERC2	597
PCON-CA/CFA	Position Controller for RCP4 (with high output driver) /RCP3/RCP2	PCON-CA / CFA	607
PCON	Position Controller for RCP3/RCP2	PCON-CY / PL / PO / SE	623
ACON	Position Controller for RCA2/RCA/RCL	ACON-C / CG / CY / PL / PO / SE	631
PCON-ABU ACON-ABU	Simple Absolute Unit for PCON/ACON Controller	PCON / ACON-ABU	641
SCON-CA	Position Controller for RCS3/RCS2	SCON-CA	643
MSCON	Position Controller for RCS3/RCS2, 6-axis type	MSCON-C	655
PSEL	Program Controller for RCP3/RCP2	PSEL-CS	665
ASEL	Program Controller for RCA2/RCA/RCL	ASEL-CS	675
SSEL	Program Controller for RCS3/RCS2	SSEL-CS	685
XSEL	Multi-axis Program Controller for RCS3/RCS2	X-SEL-J / K / P / Q / R / S	695
PS-24	24-VDC Power Supply for ROBO Cylinder	PS-241 / 242	717

Controller

PMEC
AMECPSEP
ASEP
DSEP

MSEP

ERC3

ERC2

PCON
-CA

PCON

ACON

SCON
-CA

MSCON

PSEL

ASEL

SSEL









XSEL

PS-24

Pulse
MotorServo
Motor
(24V)Servo
Motor
(200V)Linear
Servo
Motor

Controller

Controller/Actuator Correspondence Table

Classification		Positioner Type								
Controller model		PMEC-C	AMEC-C	PSEP-C /W	ASEP-C /W	DSEP-C /W	MSEP-C	PCON-CA	PCON-CFA	PCON-CY/PL/PO/SE
Appearance										
Input voltage		AC100V AC200V	AC100V	DC24V						
Number of controllable axes		1 axis only				1 to 8 axes		1 axis only		
Motor type (*1)		20P, 20SP, 28P, 28SP, 35P, 42P, 56P	2, 5, 5S, 10, 20, 20S, 30	20P, 20SP, 28P, 28SP, 35P, 42P, 56P	2, 5, 5S, 10, 20, 20S, 30	2.5	20P, 20SP, 28P, 28SP, 35P, 42P, 56P	60P, 86P	20P, 20SP, 28P, 28SP, 35P, 42P, 56P	
Supported actuators	Slider type	RCP4					●	●		
		RCP2/RCP3	●		●		●	●	●	
		RCP2-HS8□							●	
		RCA/RCA2		●		●		●		
		RCA2-SA2A□		●		●		●		
	RCS2/RCS3									
	Rod type	RCP4						●	●	
		RCP3	●		●			●	●	●
		RCP4-RA8□/RA10□							●	
		RCP2	●		●			●	●	●
		RCA/RCA2		●		●		●		
		RCA2-RA2A□		●		●		●		
		RCS2								
		RCS2-□□5N								
		RCS2-RA13R								
	RCS2-RA13R with Load cell									
	RCD					●				
	Table type	RCP3	●		●			●	●	●
		RCA/RCA2		●		●		●		
		RCA2-□□3NA/□□4NA		●		●		●		
		RCS2								
		RCS2-□□□5N								
	Gripper type	RCP2	●		●			●	●	●
		RCS2								
	Rotary type	RCP2	● (*3)		● (*3)			●	●	●
		RCS2								
	Linear Servo type	RCL		●		●		●		
	Cleanroom type	RCP4CR						●	●	
		RCP2CR	●		●			●	●	●
		RCP2CR-HS8□							●	
RCACR			●		●		●			
RCS2CR/RCS3CR										
Dustproof/splash-proof type	RCP4W							●		
	RCP2W	●		●			●	●	●	
	RCAW		●		●		●			
	RCS2W									
Position detection method		Incremental		Incremental Simple Absolute		Incremental	Incremental Simple Absolute		Incremental	Incremental (Simple absolute unit can be connected)
Supported absolute batteries		—		SEP-ABUM SEP-ABUM-W		—	MSEP-ABB	AB-7 SEP-ABU SEP-ABUS	—	PCON-ABU
Number of programs		No program is required.								
Number of program steps										
Number of multi-tasking programs										
Number of positions		Max. 3 points				Max. 3 points	Max. 512 points			
Data input tool	Teaching pendant	SEP-PT/CON-PTA-C/ CON-PDA-C/CON-PGAS-C-S				CON-PTA-C CON-PDA-C CON-PGA-C-S	CON-PTA-C CON-T/TGS CON-PDA-C CON-PGAS-C-S		CON-PTA-C CON-T/TGS CON-PDA-C CON-PGA-C-S	
	PC software	MEC PC software (Free)		RCM-101-MW RCM-101-USB						
Standard I/Os (PIOs)		4 input points/4 output points				4 input points 4 output points	16 input points 16 output points		Varies depending on the controller type	
Expansion I/Os (PIOs)		(Not expandable)								
Supported field networks	DeviceNet	—	—	—	—	—	●	●	●	—
	CC-Link	—	—	—	—	—	●	●	●	—
	PROFIBUS-DP	—	—	—	—	—	●	●	●	—
	MECHATROLINK-I/II	—	—	—	—	—	—	●	●	—
	CompoNet	—	—	—	—	—	●	●	●	—
	Ethernet	—	—	—	—	—	—	—	—	—
	EtherNet/IP	—	—	—	—	—	—	●	●	—
EtherCAT	—	—	—	—	—	(*)5	●	●	—	
Regenerative resistor unit		—	—	—	—	—	—	—	—	

(*1) The "Motor type" field indicates the motor size for a pulse motor (□P) and motor wattage for a servo motor.

(*2) RCS2-RA7/SRA7/□□5N actuators cannot be connected to XSEL-P/Q controllers of 5/6-axis type, XSEL-R/S controllers or MSCON controllers.

Controller Overview

The ROBO Cylinder model can be selected from an ultra-simple type, which is operable with the same controls as a solenoid valve, to a high functionality type compatible with networks; A variety of models are available according to the customer's usage.

Controller types can be categorized according to the 3 groups below based on their operations.

ROBO Cylinder Controllers

- Controller
- PMEC AMEC
- PSEP ASEP DSEP
- MSEP
- ERC3
- ERC2
- PCON -CA
- PCON
- ACON
- SCON -CA
- MSCON
- PSEL
- ASEL
- SSEL
- XSEL
- PS-24
- Pulse Motor
- Servo Motor (24V)
- Servo Motor (200V)
- Linear Servo Motor

Positioner Type

- Operable simply with an ON/OFF signal; easy-to-operate type.
- Operable with the same signal as a solenoid valve.
- Pulse train input type is available as well which is operable freely based on the customer's control.

Program Type

- Standalone operation available without master devices such as a PLC.
- Interpolated motion for 2-6 axes is possible; available for application and transferring movements.

Network Type

- Connection to a main field network such as DeviceNet, CC-link, or EtherNet/IP is available; applicable for large scale equipment.
- Position can be specified directly using a numeric value; there will be no limit of positioning points.
- Only one dedicated cable is needed; The number of operational steps will be significantly reduced.

See
page 529.

See
page 531.

See
page 533.



3-Position Controller
AC100V/AC200V Type
PMEC/AMEC



3-Position Controller
DC24V Type
PSEP/ASEP/DSEP



Position Controller
DC24V/AC100V/AC200V Type
PCON/ACON/SCON



Program Controller
DC24V Type
PSEL/ASEL



Program Controller
AC100V/AC200V Type
SSEL/XSEL



Network
Controller
DC24V Type
MSEP



Network
Dedicated
Controller
DC24V Type
MSCON



Network Compatible Controller
DC24V/AC100V/AC200V Type
PCON/ACON/SCON/PSEL/ASEL/SSEL/XSEL

Positioner Type

The positioner type controller stores positions to which the actuator is moved by specifying a target position number.

If you are considering motorizing your air-cylinder system, the positioner type is an ideal choice because this controller can directly use the signals you have been using to operate your air cylinder. This means that you can motorize your system with minimum changes to significantly improve the productivity of your system.

1 No programming needed

The positioner type controller operates by selecting the target position number externally using I/O after teaching the position data.

Therefore, no operation programming is needed, allowing for immediate operation directly after mounting to the equipment.

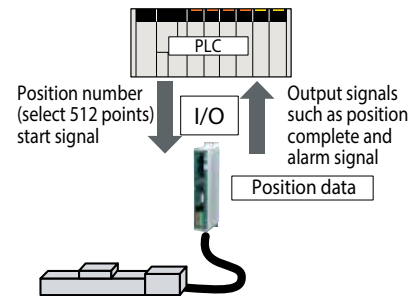

2 Operation using the same signal as solenoid valve possible (PMEC/AMEC, PSEP/ASEP/DSEP controllers)

Same as single solenoid-type valve, traveling between front/back ends is possible only by the single ON/OFF.

Furthermore, if the double solenoid-type valve signal (two signals) are used, positioning at 3 points including an intermediate position is possible.

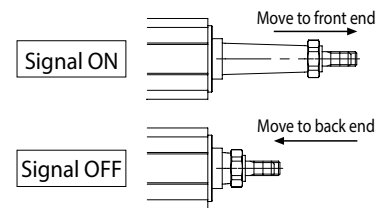

3 Reasonable price

A reasonable price range is offered for the pulse motor type controllers which maintain the effective functionality of a servo motor.

The PMEC controller, including the power supply, PC software and communication cable, is sold as a set at a reasonable price.



4 Wide Variations and Functions

Positioner controllers are available in many different types, from the 3-point positioning type that accepts the same operation signals used for air cylinders, to the enhanced positioning type accommodating up to 512 points and the space-saving type that can connect up to 8 axes per controller. Choose the type that best meets your specific application.

Each controller also comes with various functions including smart tuning and maintenance, all designed to fully demonstrate the performance of your actuator.

PMEC/AMEC Controller

- Every element needed for operation such as the controller, power supply, PC software and communication cable, etc. are supplied in the set so that direct operation right after the purchase is possible.
- Intuitive operation is possible without the need for instruction. Acceleration/deceleration and speed can be programmed from the front panel of the controller.
- Operable with the same signals as a solenoid valve.
- Power supply of the controller is single-phase AC100V/AC200V (Only AC100V for AMEC)



See page 537.

PSEP/ASEP Controller

- Operable with the same signals as a solenoid valve.
- Splash-proof type having good resistance to water splashes.
- Simple absolute type setting which eliminates the need for home return upon power-on.
- Controller power supply: DC24V



See page 547.

PCON/ACON/SCON/MSEP Controller

- Positioning is possible for up to 512 points.
- Compatible for pulse train input control. (MSEP is excluded)
- When combined with the RCP4, the PCON-CA achieves significantly higher performance of up to 1.5 times the maximum speed and twice the payload of an existing model of comparable size.
- With the offboard tuning function you can increase the maximum acceleration/deceleration of the SCON-CA to 2G.
- Despite its compact body, the MSEP is able to connect and operate up to 8 actuator axes.
- You can choose the absolute specification(*) that makes home return no longer necessary, for all controllers in the PCON, ACON, SCON and MSEP series.

(*) PCON, ACON and MSEP series are simple absolute specifications.



See page 607.



See page 631.



See page 643.



See page 563.

PMEC
AMEC

PSEP
ASEP
DSEP

MSEP

ERC3

ERC2

PCON
-CA

PCON

ACON

SCON
-CA

MSCON

PSEL

ASEL

SSEL

XSEL

PS-24

Pulse
Motor

Servo
Motor
(24V)

Servo
Motor
(200V)

Linear
Servo
Motor

Program Type

The program type controller executes programs that are input to it.

Programs input to the controller are used to perform various tasks such as operating the actuator and communicating with external equipment. Ideal for small systems where a PLC is not required which leads to cost savings.

1 High-level control available using simple language.

A program is generated for the program type controller using the simple and easy Super SEL Language to execute operation of the actuator and communication between peripheral equipment.

Expert knowledge is not needed to use the Super SEL Language, so it's easy to create programs even for beginners.

No.	B	E	N	Cnd	Cmd	Operand 1	Operand 2
1					HOME	100	
2					HOME	11	
3					VEL	200	
4					WTON	1	
5					MOVL	1	
6					BTON	301	
7					WTON	2	
8					BTOF	301	
9					MOVL	2	
10					BTON	302	

2 Interpolation possible up to 2/8 axes

Simultaneous movement of the actuators is possible up to 2 axes for PSEL/ASEL/SSEL controllers and 8 axes for the XSEL controller.

Depending on the program, interpolation is available to easily perform arc or path movements needed for dispensing jobs.

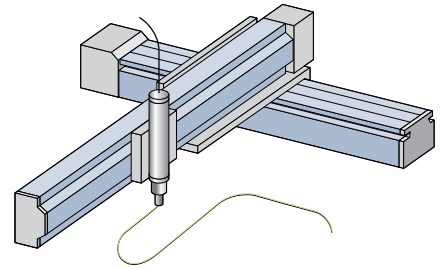

3 Controlling external equipment is possible

Multi-purpose I/O signals are available for the controller which makes communication with peripheral equipment possible.

Therefore, receiving signals from sensors and such through the controller or outputting signals from the controller to lamps or moving equipment, etc. to operate them is possible.

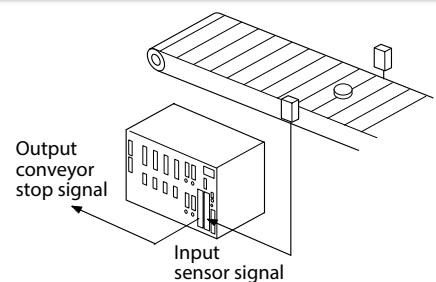

4 No home return needed for absolute type and simple absolute type

A direct operation without home return is possible upon power-on if an absolute type actuator and controller are applied for ASEL/SSEL/XSEL Controllers.

The PSEL controller is also operable without home return just like an absolute type actuator by installing the simple absolute unit between the actuator and the controller.



PSEL/ASEL/SSEL Controller

- Program controller with reasonable price and compact body.
- Interpolation of up to 2 axes is possible which is applicable for dispensing jobs.
- By selecting the positioner mode, can be used in the same manner as the position controller.
- Communication via PC USB port and direct USB cable is possible with integrated USB port.
- Can store up to 1500 points for PSEL/ASEL and 20,000 points for SSEL.
- Absolute type available for ASEL/SSEL controllers. PSEL controller is available for the same operation if a simple absolute unit is connected.
- Controller power supply is DC24V for PSEL/ASEL and single-phase AC100V/200V for SSEL.



See page 665.



See page 675.



See page 685.

XSEL Controller

- High-function controller with up to 8 axes that can be simultaneously controlled.
- Precise dispensing jobs are possible through high velocity uniformity and tracking accuracy.
- Absolute type available for selection.
- A maximum of 53,332 points can be stored for positioning.
- Expansion I/O is available up to a maximum of 576 points.
- Up to 16 PCON/ACON/SCON/MSEP controller axes can be connected via serial communication or field network to operate ROBO Cylinders using programs stored in the XSEL controller.



See page 695.

Network Type

The network type controller is available for field networks or serial communication. Compatible with the majority of main field networks widely used over the world. There is a large variety available for use with various kinds of FA equipment such as a PLC or touch panel, etc.

1 Compatible with main field networks

Direct connection is possible with main field networks such as DeviceNet or CC-Link, etc.

A position controller is available for an operation defined by movement specified with position number and direct coordinate value using the network. (When defining coordinate values directly, there is no restriction for the number of positioning points.)



Compatible Networks and Functions

Controller series		Positioner Type					Program Type			
		PCON-CA	ACON	SCON-CA	MSEP	MSCON	PSEL	ASEL	SSEL	XSEL
Appearance										
Field network types	DeviceNet	●	●	●	●	●	●	●	●	●
	CC-Link	●	●	●	●	●	●	●	●	●
	PROFIBUS-DP	●	●	●	●	●	●	●	●	●
	MECHATROLINK -I/II	●	●	●	—	—	—	—	—	—
	CompoNet	●	●	●	●	●	—	—	—	—
	Ethernet	—	—	—	—	—	—	—	—	●
	EtherNet/IP	●	●	●	●	●	—	—	—	●
	EtherCAT	●	●	●	(*2)	(*2)	—	—	—	●
Applicable ROBO Cylinder		RCP4 RCP3 RCP2	RCA2 RCA RCL	RCS3 RCS2	RCP4 RCP3 RCP2 RCA2 RCA RCL	RCS3 RCS2	RCP3 RCP2	RCA2 RCA RCL	RCS3 RCS2	RCS3 RCS2
Maximum number of positioning points (*1)		768 points			256 points		1,500 points		20,000 points	53,332 points
Operating method	Movement by specifying positions	○	○	○	○	○	○	○	○	○
	Movement by specifying direct values	○	○	○	○	○	X	X	X	X

(*1) When it is operated by movement by specifying direct values, the number of positioning points is unlimited. (*2) To be released soon.

2 Operating Up to 16 ROBO Cylinder Axes from One XSEL Controller

The RC gateway function of the XSEL controller lets you connect multiple ROBO Cylinder controllers via serial communication or DeviceNet communication to operate up to 16 axes using programs stored in the XSEL controller. Combined with up to 8 axes that can be operated directly by the XSEL controller, you can effortlessly operate a maximum of 24 axes from one controller.

Another advantage is that wiring is much easier compared to when ROBO Cylinder controllers are PIO-controlled.

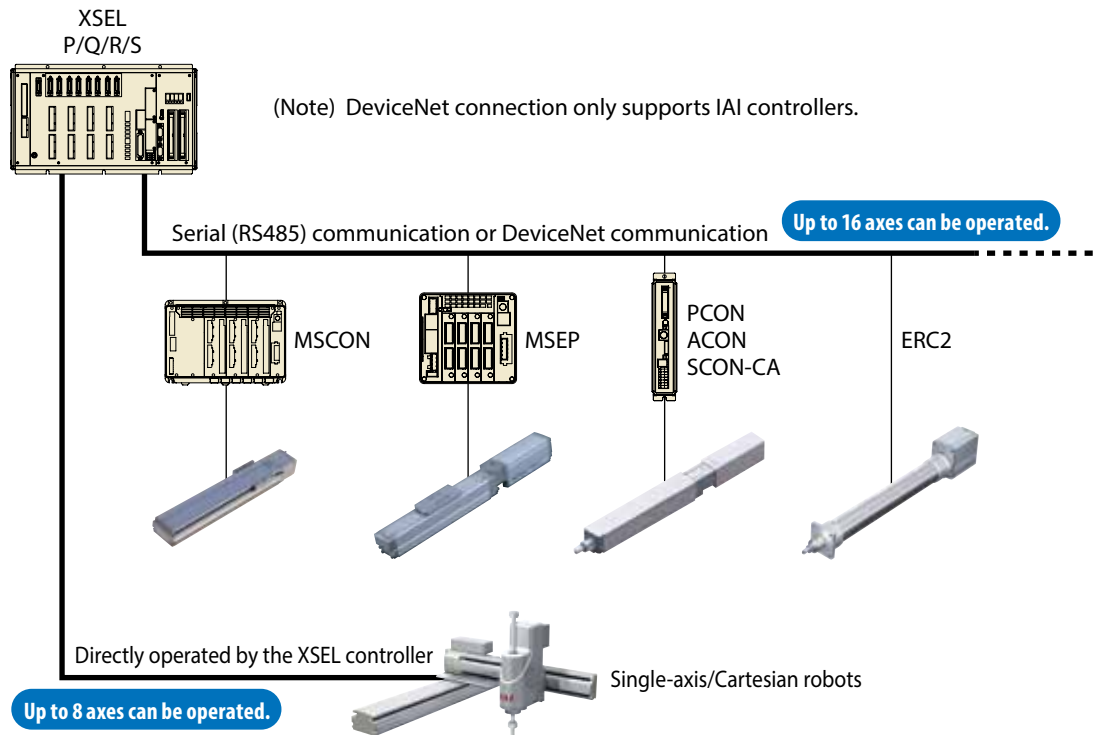

Specification

	Serial Communication Type	DeviceNet Communication Type
Supported controllers	XSEL-P/Q/R/S type	XSEL-P/Q/R/S type (*1)
Connectable controllers	ERC2-SE PCON-SE/ACON-SE SCON-CA ROBONET	PCON-DV/ACON-DV SCON-DV/MSEP-DV MSCON-DV * All controllers must be of the DeviceNet specification.
Maximum number of connectable ROBO Cylinder axes	16	16
Baud rate	230.4kbps	500kbps
Communication cable length	Total cable length of no more than 100m	Total cable length of no more than 100m
Required connection equipment	RCB-CV-GW CB-RCB-SIO050 CB-RCB-CTL002	DeviceNet gateway master board (*2)

(*1) XSEL-P/Q controllers of DeviceNet communication type must be custom-ordered. (XSEL-R/S controllers of this type are available as standard models.)

(*2) Your XSEL controller will come with this board if an applicable code is specified in the model name of the controller.

Network Type

3 Vision System

With the XSEL controller, you can directly connect a vision system of any leading brand to take advantage of the convenience of vision system functions, such as reading coordinate values into the controller and using these coordinates to move actuators.

(1) Any leading vision system can be connected directly

High-functional vision systems from leading brands, such as Omron, Keyence and Cognex, can be used with ease.



Examples of vision system models				
Brand	Model			Interface
Cognex	In-Sight 5000 series			Ethernet
Omron	F210-C10	FZ3	—	RS232C
Keyence	CV2000	CV3000	CV5000	XG-7000
				Ethernet RS232C

(2) No need for complex communication programs

Coordinates read by the camera are sent to the robot controller via a dedicated command and stored as part of position data in the controller. There is no need for complex communication programs, etc.

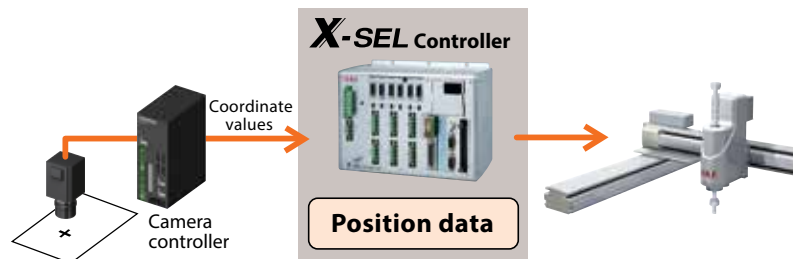

(3) Able to communicate with other networks while communicating with the vision system via Ethernet

XSEL-R/S controllers can communicate with DeviceNet, CC-Link or PROFIBUS-DP while communicating with the vision system via EtherNet/IP or EtherCAT.

This means that, for example, you can use Ethernet for communication between the XSEL controller and vision system, while allowing the XSEL controller to send and receive I/Os to/from peripherals via a CC-Link network.

* XSEL-P/Q controllers can be set up to support one network selected from the types mentioned above.

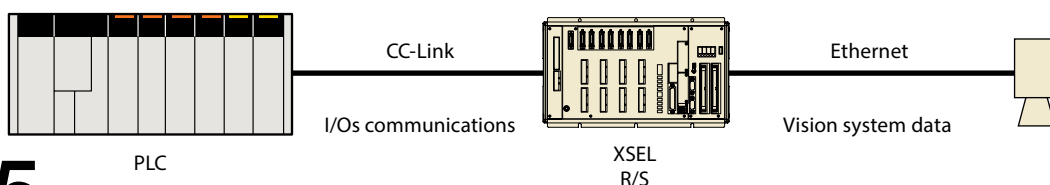

535

Controller

MSEP Controller

- Up to 8 axes of pulse/servo motor actuators can be connected to this compact controller of just 123mm (W) x 115mm (H) in size. The compact body, which is 60% slimmer than a comparable model, saves space in the control panel.
- You can specify the target position numerically.
- Significantly shorter communication time within the controller. (Supported actuators) RCP4/RCP3/RCP2/RCA2/RCA/RCL series



See page
563.

MSCON Controller

- Dedicated low-cost network controller of space-saving design that connects up to 6 axes.
- You can specify the target position numerically.
- Significantly shorter communication time within the controller. (Supported actuators) RCS3/RCS2 series.



See page
655.

Controller compatible with field network *Network type set for each controller



See page
607.



See page
631.



See page
643.



See page
665.



See page
675.



See page
658.

- Able to connect to major networks directly.
- The position controllers let you operate your actuator by directly sending the values of target position, speed, acceleration, etc., via network.



See page
695.

- Controller
- PMEC
AMEC
- PSEP
ASEP
DSEP
- MSEP
- ERC3
- ERC2
- PCON
-CA
- PCON
- ACON
- SCON
-CA
- MSCON
- PSEL
- ASEL
- SSEL
- XSEL
- PS-24
- Pulse Motor
- Servo Motor (24V)
- Servo Motor (200V)
- Linear Servo Motor

PMEC

3-position, AC100/200V controller for RCP2/RCP3 Series

AMEC

3-position, AC100V controller for RCA/RCA2/RCL Series



ROBO Cylinder 3-position controller MEC (Mechanical Engineer Control)

Feature

1 Low Cost

The MEC package, which combines a controller, power supply, acceleration/speed change function and PC connection cable, among others, is at an affordable price. The MEC PC software can be downloaded free of charge from IAI's website.



2 Easy Operation

Even a beginner can set up the controller without reading the operation manual. The acceleration and speed can be adjusted using the knobs on the controller.

* The setting range for acceleration/speed varies depending on the actuator. Please refer to the instruction manual for further detail.

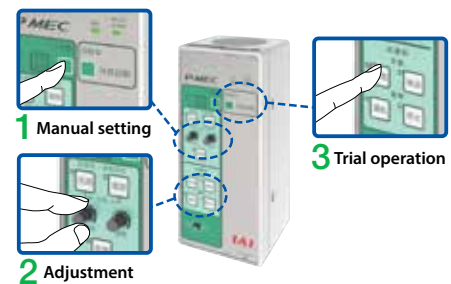

3 Easy Replacement from your Air-cylinder System

Operation signals are exactly the same as those used to operate air cylinders. This means that you can use the program of your current PLC directly.

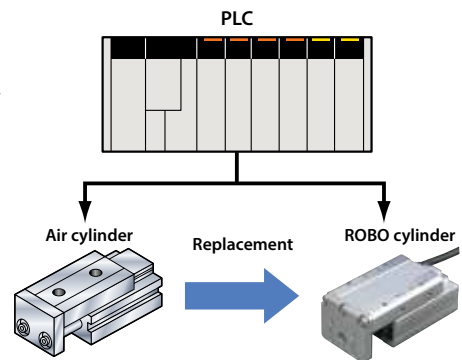

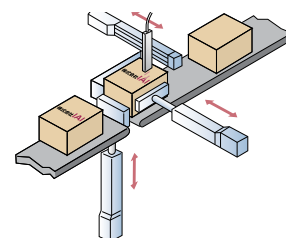

4 Push-motion Operation/Intermediate Stopping

Push-motion operation can be performed in the same manner as you would with any air-cylinder system. Also, you can cause the actuator to stop at any desired intermediate point between the home position and stroke end by changing the setting of the intermediate point using the MEC PC software.



Model List

Series	PMEC	AMEC
External View		
Applicable actuators	RCP2 / RCP3	
Power supply voltage	100V	100V-240V
Accessories	AC power supply cable (2m) USB cable (3m) I/O cable (2m) I/O connector EMG connector Standard mounting bracket	

Model

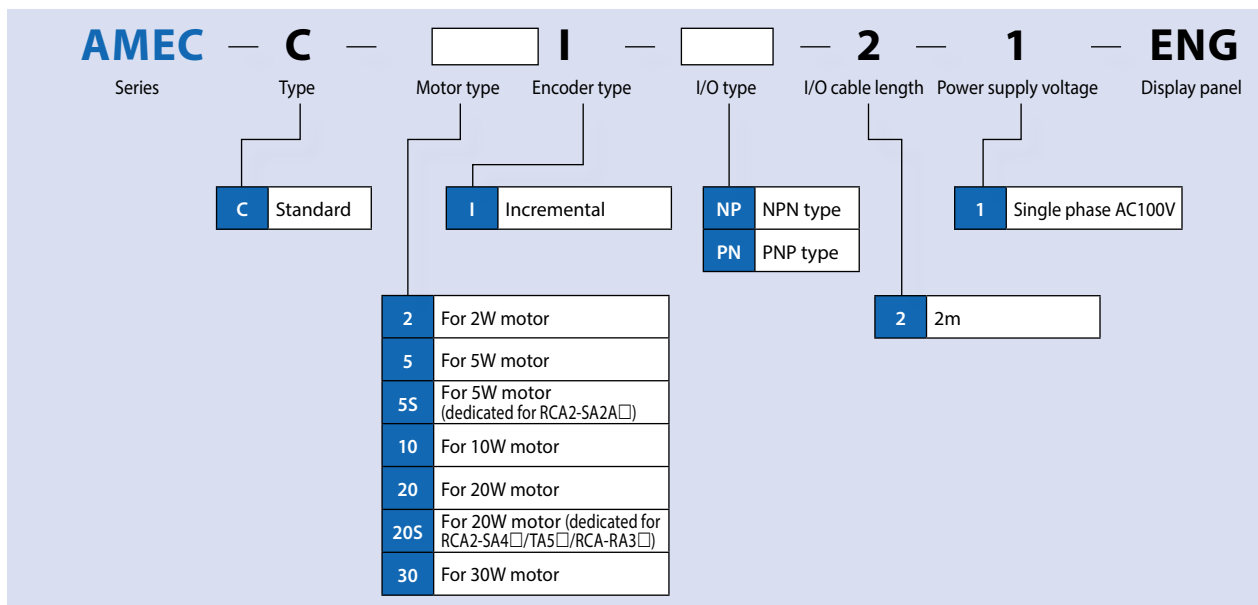
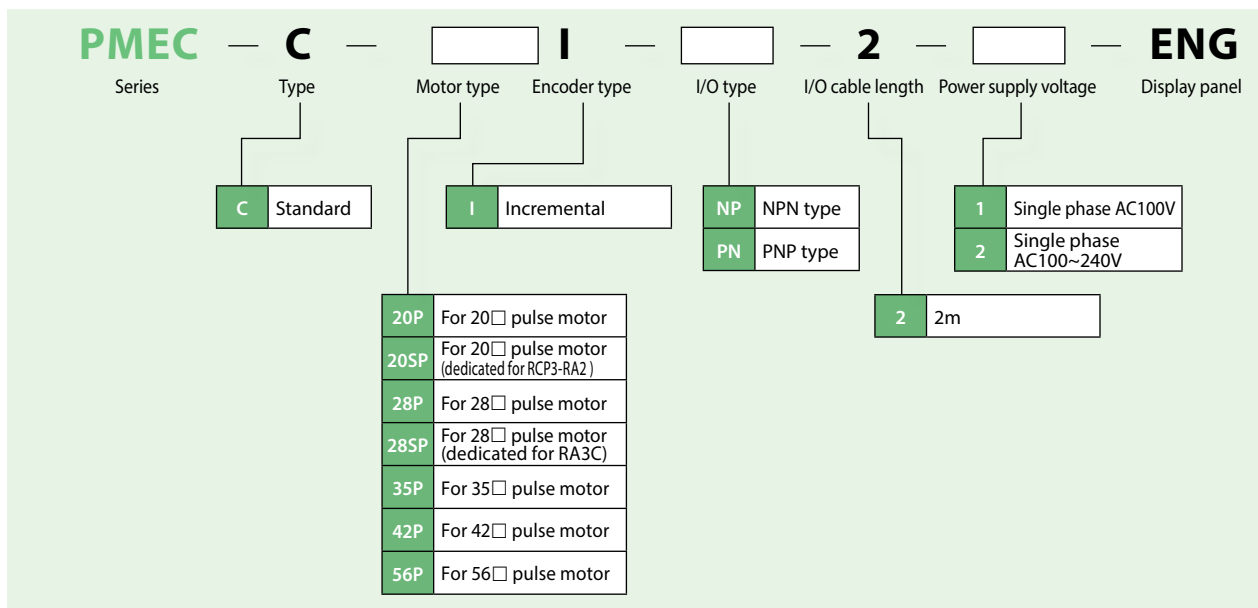

- Controller
- PMEC
AMEC
- PSEP
ASEP
DSEP
- MSEP
- ERC3
- ERC2
- PCON
-CA
- PCON
- ACON
- SCON
-CA
- MCON
- PSEL
- ASEL
- SSEL
- XSEL
- PS-24
- Pulse Motor
- Servo Motor (24V)
- Servo Motor (200V)
- Linear Servo Motor

System Configuration

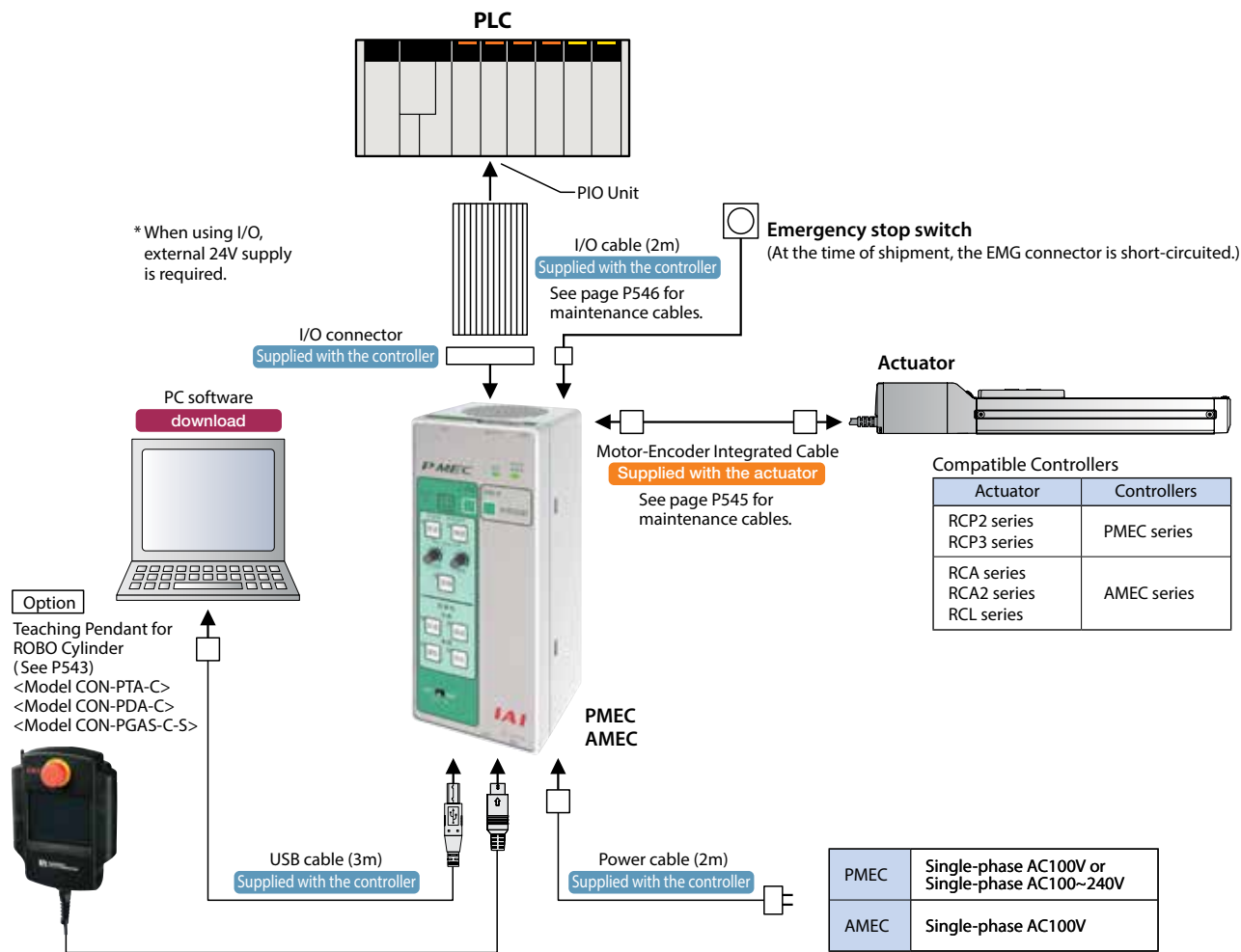

I/O Signal Table

(Note) External power supply is needed.

Motion Pattern			2-Position Travel		3-Position Travel	
Pin No.	Wire Color	Signal Type	Signal Name		Signal Name	
1	Brown	PIO power	24V (Note)		24V (Note)	
2	Red		0V (Note)		0V (Note)	
3	Orange	Input	ST0 (Solenoid A: ON moves to end position, OFF moves to home position)		ST0 (Solenoid A: Move signal 1)	
4	Yellow		—		ST1 (Solenoid B: Move signal 2)	
5	Green		RES (Alarm reset)		RES (Alarm reset)	
6	Blue		—		—	
7	Purple	Output	LS0 (home position detection)/PE0 (home positioning complete)*1		LS0 (home position detection)/PE0 (home positioning complete)*1	
8	Gray		LS1 (end position detection)/PE1 (end positioning complete)*1		LS1 (end position detection)/PE1 (end positioning complete)*1	
9	White		HEND (Homing complete)		LS2 (intermediate point detection)/PE2 (intermediate positioning complete)*1	
10	Black		*ALM (alarm)*2		*ALM (alarm)*2	

*1: Signals PE0 through PE2 will be output if the pushing motion was enabled in the initial setting. Otherwise, LS0 through LS2 will be output.
*2: *ALM is ON when normal, and OFF when it is activated.

MEC PC software

By using the MEC PC software you can change the stop position data or run a test operation.

In addition, you can change the setting on the intermediate stop function, pushing function or change the coordinates.

The MEC PC software can be downloaded from the IAI website.

IAI Website: www.intelligentactuator.com

Explanation of PIO Patterns

PIO Pattern (2-position travel)

This motion pattern is between two positions, the home position and the end position. The home and end positions can be configured numerically (using the MEC PC software or the optional touch panel teaching pendant). Two motions are possible: A positioning motion moves the rod or the slider to the specified position, and a pushing motion presses the rod against a workpiece.

Positioning

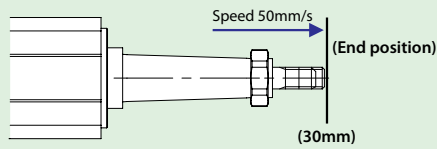

Input Signal

ST0	Solenoid A	ON
-----	------------	----

When ST0 is turned ON, the slider/rod moves at 50mm/s to the end position (30mm position).

End Position Data

Position	30mm
Speed	50mm/s
Pushing Force	—
Width	—

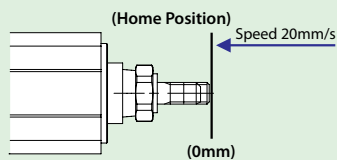

Input Signal

ST0	Solenoid A	OFF
-----	------------	-----

When ST0 is turned OFF, the slider/rod returns to the home position (0mm position) at 20mm/s.

Home Position Data

Position	0mm
Speed	20mm/s
Pushing Force	—
Width	—

PIO Pattern (2-position travel)

This motion pattern is between two positions, the home position and the end position, which enables a pushing motion of the rod against a workpiece.

Push

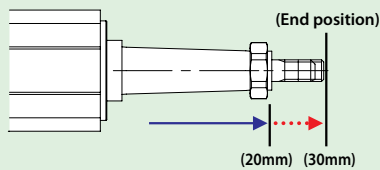

Input Signal

ST0	Solenoid A	ON
-----	------------	----

When ST0 is turned ON, the actuator moves the rod to the 20mm position at 80mm/s, and from there, pushes it at slower speed to the 30mm position.

End Position Data

Position	30mm
Speed	80mm/s
Pushing Force	50%
Width	10mm

* The pushing motion is performed when there is a numerical value in the controller's push force data. (If there is no numerical value, a positioning motion is performed instead.)

PIO Pattern (3-position travel)

This motion pattern enables moves between three positions: the end position and the home position, as well as an intermediate position.

The positions are switched by combining two signals, ST0 and ST1.

Positioning

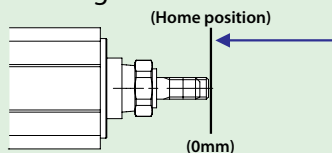

Input Signal

ST0	Solenoid A	ON
ST1	Solenoid B	OFF

When only ST0 is turned ON, the actuator moves to the starting position at a set acceleration and speed.

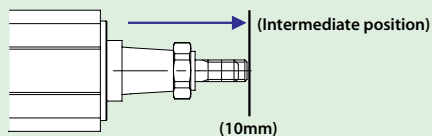

Input Signal

ST0	Solenoid A	ON*
ST1	Solenoid B	ON*

When both ST0 and ST1 are turned ON, it will move to the intermediate position at the set acceleration and speed. When both are turned OFF, it stops at the current position.

* You can also configure the initial settings so that the rod will move to the intermediate position with both signals turned OFF, and stop at the current position with both signals turned ON.

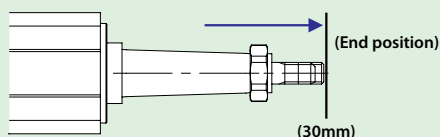

Input Signal

ST0	Solenoid A	OFF
ST1	Solenoid B	ON

When only ST1 is turned ON, the actuator moves to the end position at a set acceleration and speed.

- Controller
- PMEC
AMEC
- PSEP
ASEP
DSEP
- MSEP
- ERC3
- ERC2
- PCON
-CA
- PCON
- ACON
- SCON
-CA
- MSCON
- PSEL
- ASEL
- SSEL
- XSEL
- PS-24
- Pulse Motor
- Servo Motor (24V)
- Servo Motor (200V)
- Linear Servo Motor

Specifications Table

Item	Type		
	PMEC		AMEC
Controller Type	PMEC		AMEC
Connectible Actuators	RCP2/RCP3 Series Actuators		RCA/RCA2/RCL Series Actuators
Number of Controllable Axes	Single axis		
Operation Method	Positioner Type		
Number of Positions	2 positions / 3 positions		
Backup Memory	EEPROM		
I/O Connector	10-pin terminal block		
I/O Points	4 input points / 4 output points		
Power for I/O	Externally supplied DC24V±10%		
Serial Communication	RS485: 1ch/USB: 1ch		
Position Detection Method	Incremental encoder		
Power Supply Voltage	AC100~115V±10%	AC100V-240V±10%	AC100V~115V±10%
Rated Current	1.3A	0.67A (AC100V)/0.36A (AC200V)	2.4A
Rush Current	30A	15A (AC100V)/30A (AC200V)	15A
Leak Current	0.50mA max	0.40mA max (AC100V) 0.75mA max (AC200V)	0.50mA max
Dielectric Strength Voltage	DC500V 1MΩ		
Vibration Resistance	XYZ directions 10~57Hz One-side amplitude 0.035mm (continuous), 0.075mm (intermittent) 57~150Hz 4.9m/s ² (continuous), 9.8m/s ² (intermittent)		
Ambient Operating Temperature	0~40°C		
Ambient Operating Humidity	10~85% RH (non-condensing)		
Ambient Operating Atmosphere	Free from corrosive gases		
Protection Class	IP20		
Weight	500g	508g	614g

**Note: The minimum/maximum speeds vary depending on the actuator model.
For more information, see the instruction manual, or contact IAI.**

Outer Dimensions

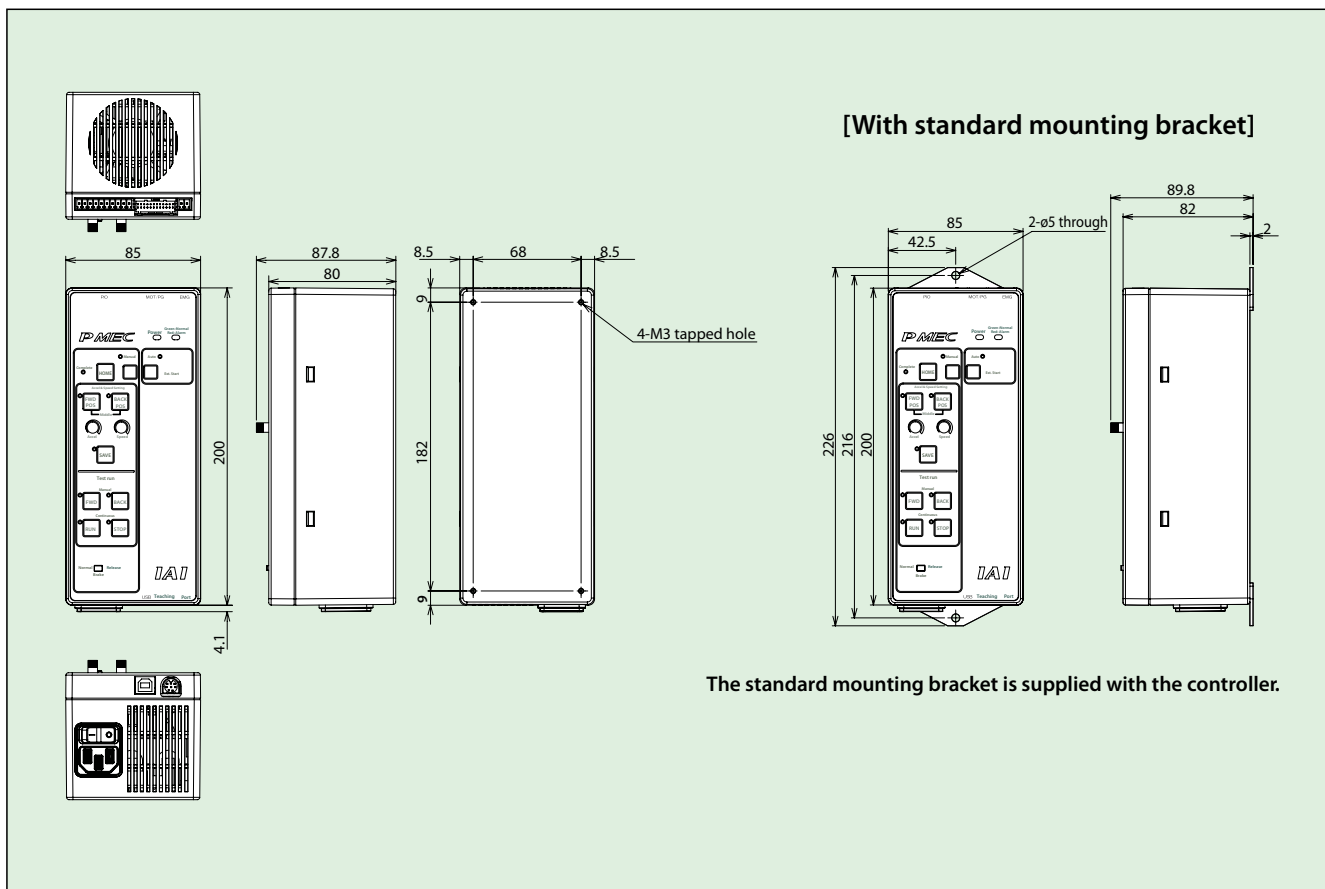

Names of Parts and Functions

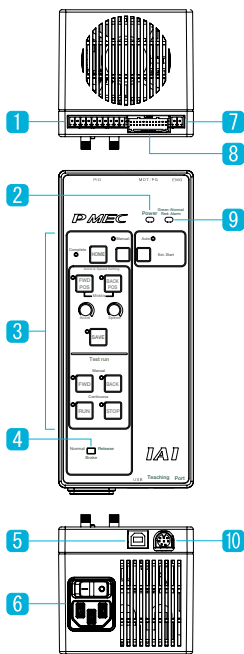

- 1 PIO connector** Connects with a PLC or other external controllers to communicate inputs and outputs (I/O).
- 2 Power LED** When the power is ON, it illuminates in green.
- 3 Control panel** See below
- 4 Brake switch**

Release	Used to release the brake of the actuator
Normal	The controller automatically controls the brake of the actuator
- 5 USB connector** When using MEC PC software, connect to the computer via USB.
- 6 AC inlet** Insert the power supply cable.
- 7 EMG connector** Connect the emergency stop button. Short-circuit it if you will not be using an emergency stop button.
- 8 M/PG connector** Insert the motor/encoder cable that connects with the actuator.
- 9 Status LED**

RUN (Green)	Indicates the servo status. On = Servo ON, Off=Servo OFF (Energy-saving) status Flashing (1Hz)=Auto servo OFF
ALM (Red) EMG (Red)	The LED illuminates if an alarm is turned ON or if the controller has come to an emergency stop.
- 10 SIO Connector** Connects with the teaching pendant (CON-PTA, SEP-PT).

Explanation of the Control Panel

HOME button

When starting, homing is performed first to confirm the 0mm coordinate.

Manual button

Press this button to set the acceleration and/or speed, or to run a test operation. (Press for at least 1 second)

AUTO button

Press this button when operating from the MEC PC software or the PLC commands. (Press for at least 1 second)

Acceleration/Speed Settings

Configure the actuator's motion.

FWD POS / **BACK POS** buttons

Switch the motion you want to configure (see types below).

FWD POS: Motion toward the end position
BACK POS: Motion toward the home position
Middle: Motion toward the middle position (Enabled from the MEC PC software and switched on by simultaneously pressing "FWD POS" and "BACK POS" buttons to switch. During a 2-position stop, simultaneous pressing is disabled.)

Acceleration / **Speed** knobs

By turning the knob, you can change the speed between 1%~100% of the actuator's maximum speed or rated acceleration / deceleration.

* The minimum speed may be less than 1% in some cases.

SAVE button

Saves the speed and acceleration adjusted above.

Test Operation

Confirm the saved motion by physically running the actuator.

FWD button

In a 2-position travel, the actuator moves from the BACK position to the FWD position. In a 3-position travel, the actuator moves from the BACK position to the middle position, then to the FWD position.

BACK button

The actuator returns to the home position.

RUN button

In a 2-position travel, the actuator moves back and forth between the FWD and BACK positions. In a 3-position travel, the actuator repeats its movement from the BACK position, middle position, FWD position, then BACK position.

STOP button

Stops the above operation.

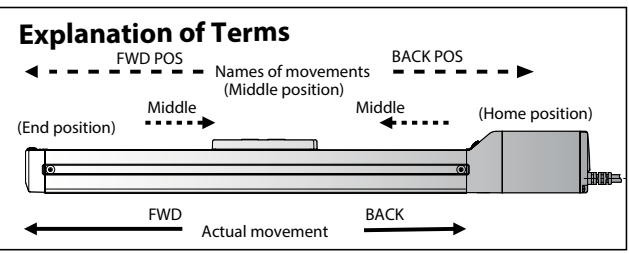

- Controller
- PMEC
AMEC
- PSEP
ASEP
DSEP
- MSEP
- ERC3
- ERC2
- PCON
-CA
- PCON
- ACON
- SCON
-CA
- MSCON
- PSEL
- ASEL
- SSEL
- XSEL
- PS-24
- Pulse Motor
- Servo Motor (24V)
- Servo Motor (200V)
- Linear Servo Motor

Options

Touch-panel Teaching Pendant for Position Controller CON-PTA/PDA/PGAS

Adopting an easy-to-use interactive touch-panel menu screen, these simple data devices can be operated without consulting to the manuals.



1. Color screen for greater ease of view
2. Supporting the takt time minimization function and maintenance information checking/input functions.
3. Position, parameters and other data can be saved in a SD card
4. Built-in clock function records the date & time of each event; data can then be saved in a SD card.

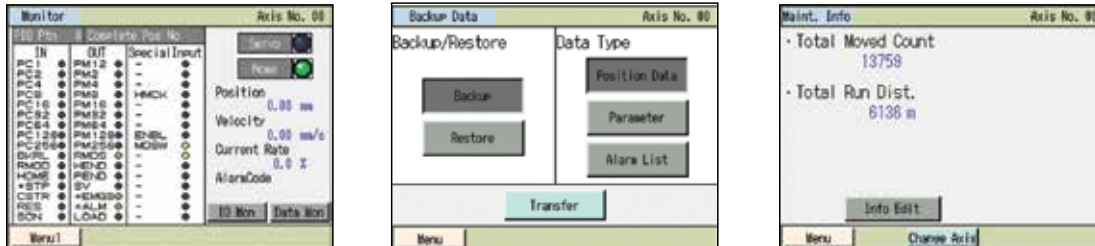

Model Numbers/Specifications

Item	Description		
	CON-PTA-C-ENG	CON-PDA-C-ENG	CON-PGAS-C-S-ENG (set)
Model number	CON-PTA-C-ENG	CON-PDA-C-ENG	CON-PGAS-C-S-ENG (set)
Type	Standard type	Enable switch type	Safety-category compliant type
Connectable controllers	ACON/PCON/SCON/RACON/RPCON/MSCON/ASEP/PSEP/MSEP/DSEP/AMEC/PMEC /ERC2 (*1) /ERC3		
3-position enable switch	×	○	○
Functions	<ul style="list-style-type: none"> • Position data input/editing • Moving function (moving to set positions, jogging/inching) • Parameter editing • Monitoring (current position, current speed, I/O signals, alarm code, alarm generation time) • Saving/reading data to/from external SD cards (position data parameters, alarm list) • Takt time minimization function • Maintenance information (total number of movements, total distance travelled, etc.) 		
Display	65,536 colors (16-bit colors), white LED backlight		
Ambient operating temperature/humidity	0 to 40°C, 85% RH or less (Non-condensing)		
Environmental resistance	IP40 or equivalent		
Mass	Approx. 570g		Approx. 600g
Cable length	5m		
Accessories	Stylus	Stylus	Stylus, TP adapter (Model number: RCB-LB-TGS) Dummy plug (Model number: DP-4S) Controller cable (Model number: CB-CON-LB005)
Standard price	—	—	—

*1 Among the ERC2 series, only the actuators bearing 4904 or greater number stamped on the serial number label can be connected.

Name of Each Part

■ Name of Each Part/External Dimensions

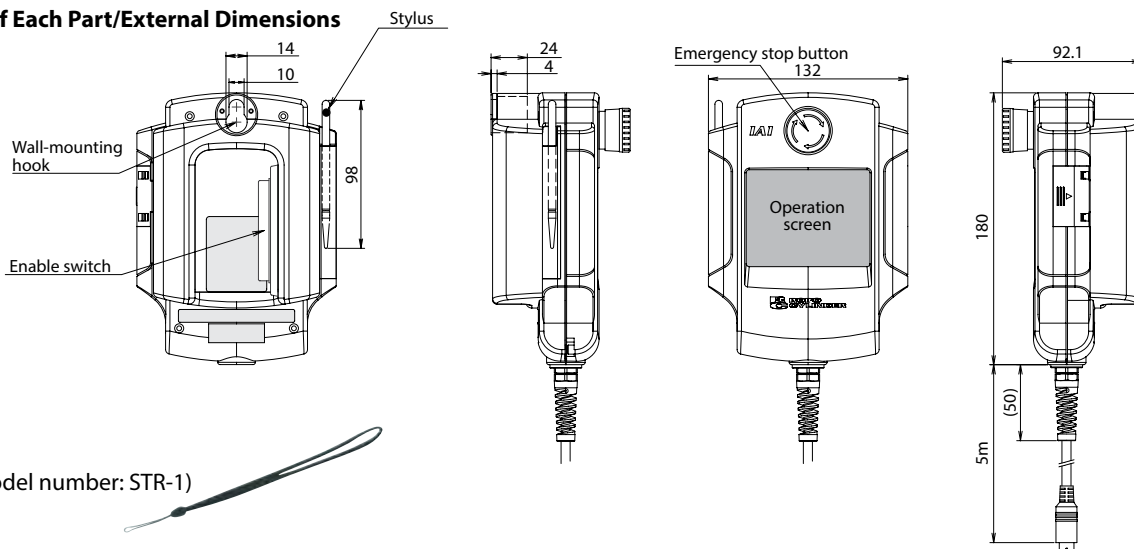

■ Option

- Strap (Model number: STR-1)

543 PMEC / AMEC

● DIN Rail Mounting Bracket MEC-AT-D

■ Dimensions

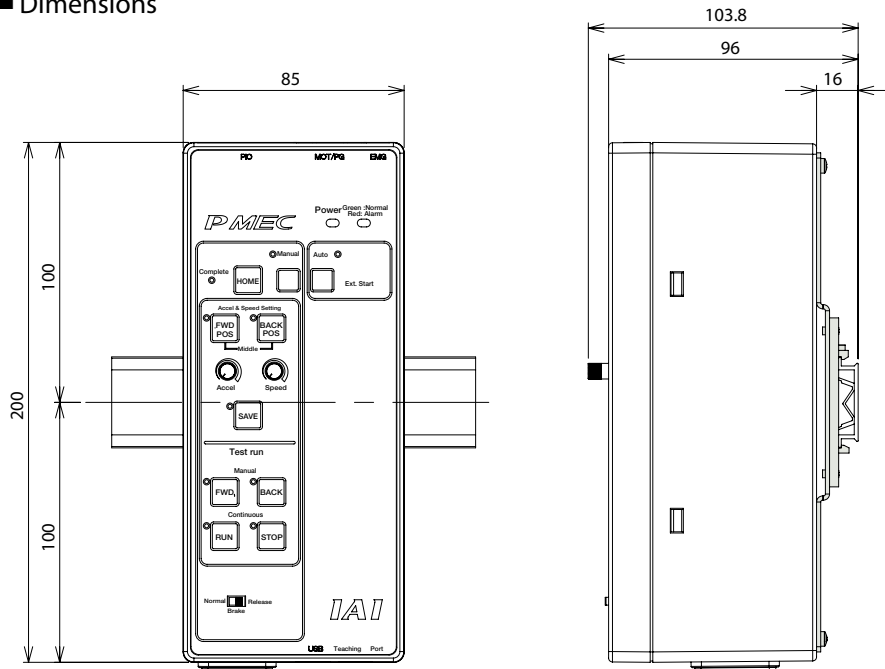

● Maintenance cable

■ List of maintenance cable models

Type	Cable length	Cable length	Model	Standard price
Integrated motor-encoder cable	PMEC ↔ RCP3 RCP2-GRSS/GRLS/ GRST/ SRA4R/SRGS4R/ SRGD4R	1m	CB-APSEP-MPA010	—
		3m	CB-APSEP-MPA030	—
		5m	CB-APSEP-MPA050	—
	AMEC ↔ RCA2/RCL	1m	CB-PSEP-MPA010	—
		3m	CB-PSEP-MPA030	—
		5m	CB-PSEP-MPA050	—
	PMEC ↔ RCP2	1m	CB-RPSEP-MPA010	—
		3m	CB-RPSEP-MPA030	—
		5m	CB-RPSEP-MPA050	—
	PMEC ↔ RCP2-RTBS/RTBSL -RTCS/RTCSL	1m	CB-ASEP-MPA010	—
		3m	CB-ASEP-MPA030	—
		5m	CB-ASEP-MPA050	—
AMEC ↔ RCA	2m	CB-APMEC-PIO020-NC	—	
	3m	CB-APMEC-PIO030-NC	—	
	5m	CB-APMEC-PIO050-NC	—	
I/O cable	3m	CB-SEL-USB030	—	

Components for maintenance

Please refer to the models listed below when arrangements such as cable replacement are needed after purchasing the product.

[RCP3/RCA2/RCL]-[PMEC/AMEC] Integrated motor-encoder robot cable for indirect connection/ Integrated motor-encoder cable

Model **CB-APSEP-MPA** / **CB-APSEP-MPA** -**LC** * indicated the cable length (L)
 Lengths up to 20m can be specified Example) 080=8m

*Refer to page A-59 for connectable actuators.

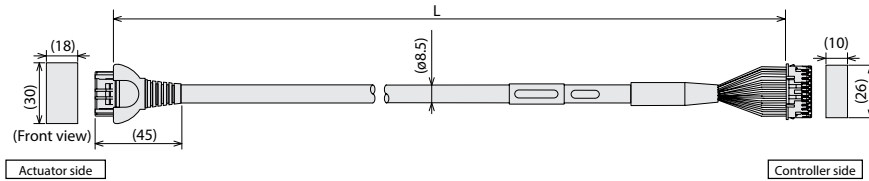

Minimum bend radius $r = 68\text{mm}$ or larger (when movable unit is used)

Actuator side Pin number		Controller side Pin number
A1	[PCON](ACON) Black [øA](U)	1
B1	White [VMM](V)	2
A2	Brown [øA](W)	5
B2	Green [øB](-)	3
A3	Yellow [VMM](-)	4
B3	Red [øB](-)	6
A4	Orange [LS+](BK+)	7
B4	Gray [LS-](BK-)	8
A6	White [-](A+)	11
B6	Yellow [-](A-)	12
A7	Red [A+](B+)	13
B7	Green [A-](B-)	14
A8	Black [B+](Z+)	15
B8	Brown [B-](Z-)	16
A5	Black (label)[BK+](LS+)	9
B5	Brown (label)[BK-](LS-)	10
A9	Green (label)[GND](S)[GND](S)	20
B9	Red (label)VPS	18
A10	White (label)VCC	17
B10	Yellow (label)GND	19
A11	NC	21
B11	Shield FG	24
	NC	22
	NC	23

[RCP2/RCP2CR/RCP2W]-[PMEC] Integrated motor-encoder robot cable for indirect connection

Model **CB-PSEP-MPA** * Robot cable is the standard specification. * indicated the cable length (L)
 Lengths up to 20m can be specified Example) 080=8m

*Refer to page A-59 for connectable actuators.

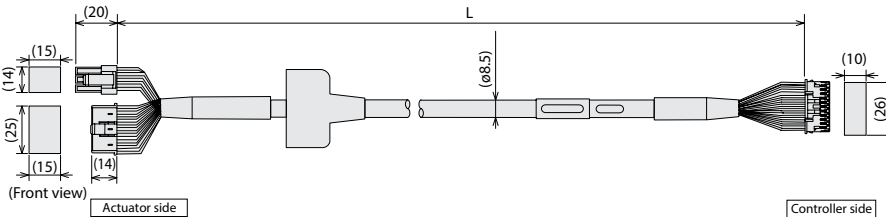

Minimum bend radius $r = 68\text{mm}$ or larger (when movable unit is used)

Actuator side Pin number		Controller side Pin number
1	Black [ØA]	1
2	White [VMM]	2
4	Red [ØB]	3
5	Green [VMM]	4
3	Brown [ØA]	5
6	Yellow [ØB]	6
16	Orange [BK+]	9
17	Gray [BK-]	10
5	NC	11
6	NC	12
13	Black [LS+]	7
14	Brown [LS-]	8
1	White [A+]	13
2	Yellow [A-]	14
3	Red [B+]	15
4	Green [B-]	16
10	White (label)[VCC]	17
11	Yellow (label)[VPS]	18
9	Red (label)[GND]	19
12	Green (label)[Spare]	20
15	NC	21
7	NC	22
8	NC	23
18	Shield [FG]	24

[RCA/RCACR/RCAW]-[AMEC] Integrated motor-encoder robot cable for indirect connection

Model **CB-ASEP-MPA** * Robot cable is the standard specification. * indicated the cable length (L)
 Lengths up to 20m can be specified Example) 080=8m

*Refer to page A-59 for connectable actuators.

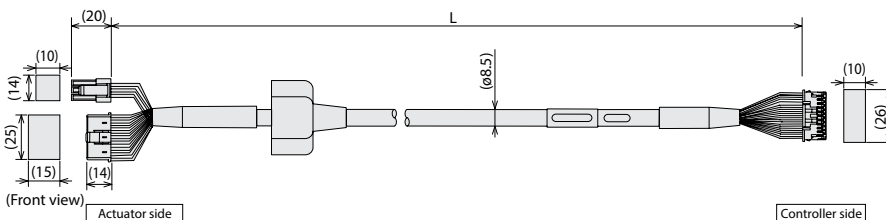

Minimum bend radius $r = 68\text{mm}$ or larger (when movable unit is used)

Actuator side Pin number		Controller side Pin number
1	Red [U]	1
2	Yellow [V]	2
-	NC	3
-	NC	4
3	Black [W]	5
-	NC	6
18	Orange [BK+]	7
17	Gray [BK-]	8
7	Black [LS+]	9
16	Brown [LS-]	10
1	White [A+]	11
2	Yellow [A-]	12
3	Red [B+]	13
4	Green [B-]	14
10	Black (label)[Z+]	15
11	Brown (label)[Z-]	16
14	White (label)[VCC]	17
13	Yellow (label)[VPS]	18
15	Red (label)[GND]	19
6	Green (label)[Spare]	20
5	NC	21
8	NC	22
12	NC	23
9	Shield [FG]	24

[RCP2-RTBS/RTBSL/RTCS/RTCSL]-[PMEC] Integrated motor-encoder robot cable for indirect connection

Model **CB-RPSEP-MPA** * Robot cable is the standard specification. * indicated the cable length (L)
Lengths up to 20m can be specified Example) 080=8m

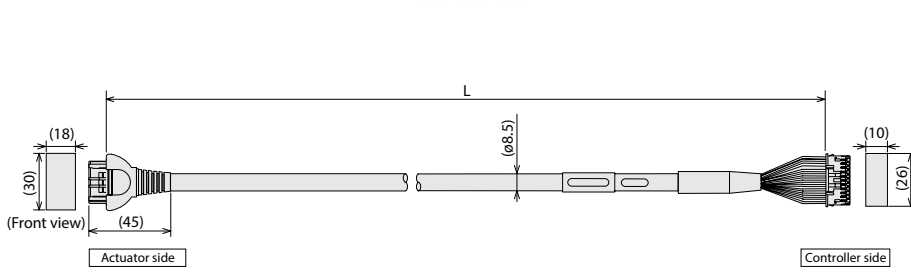

Minimum bend radius $r = 68\text{mm}$ or larger (when movable unit is used)

Actuator side		Controller side	
Pin number	Color	Pin number	Color
A1	Black [øA]	1	
B1	White [VMM]	2	
A2	Brown [ø/A]	5	
B2	Green [øB]	3	
A3	Yellow [VMM]	4	
B3	Red [ø/B]	6	
A6	Orange [LS+]	7	
B6	Gray [LS-]	8	
A7	Red [A+]	13	
B7	Green [A-]	14	
A8	Black [B+]	15	
B8	Brown [B-]	16	
A4	NC	7	
B4	NC	8	
A5	Black (label)[BK+]	9	
B5	Brown (label)[BK-]	10	
A9	Green (label)[GNDLS]	20	
B9	Red (label)[VPS]	18	
A10	White (label)[VCC]	17	
B10	Yellow (label)[GND]	19	
A11	NC	21	
B11	Shield FG	24	
		22	NC
		23	NC

I/O cable for PMEC-C/AMEC-C

Model **CB-APMEC-PIO** -NC * The 3 types differ in cable length: 020=2m, 030=3m, 050=5m

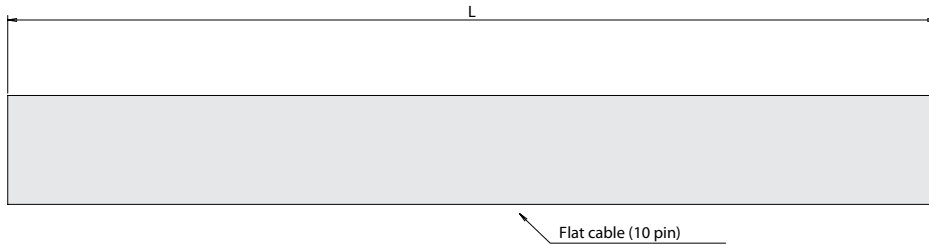

Pin NO.	Electric wire color	Signal
1	Brown	PIO Power supply
2	Red	
3	Orange	Input
4	Yellow	
5	Green	
6	Blue	
7	Purple	Output
8	Gray	
9	White	
10	Black	

- Controller
- PMEC
AMEC
- PSEP
ASEP
DSEP
- MSEP
- ERC3
- ERC2
- PCON
-CA
- PCON
- ACON
- SCON
-CA
- MSCON
- PSEL
- ASEL
- SSEL
- XSEL
- PS-24
- Pulse Motor
- Servo Motor (24V)
- Servo Motor (200V)
- Linear Servo Motor

<h1 style="font-size: 2em; margin: 0;">PSEP</h1>	<p>Model C/CW 3-position controller for RCP3/RCP2</p>	
<h1 style="font-size: 2em; margin: 0;">ASEP</h1>	<p>Model C/CW 3-position controller for RCA2/RCA/RCL</p>	
<h1 style="font-size: 2em; margin: 0;">DSEP</h1>	<p>Model C/CW 3-position controller for RCD</p>	

Feature

1 Can operate with the same signal as a solenoid valve.

The signal that operates the actuator is the same as the signal that operates the air cylinder. Therefore, the PLC program currently in use can be used without modification even if the air cylinder is replaced by an electric-powered cylinder. Either a single solenoid or a double solenoid may be used.

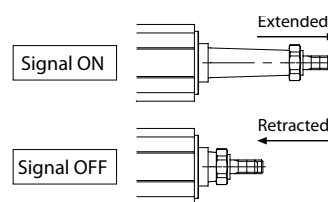

2 Establishes a dustproof type that supports IP53.

We provide dustproof type controllers with an IP53 equivalent (*1) protection structure, so that the controller can be mounted outside the control panel. (*1) The bottom surface is excluded.



3 Provides the simple absolute type that can be operated immediately upon power-ON without homing.

Since the simple absolute type can store the current position with the assistance of the absolute battery unit during power-up or after the emergency stop is deactivated; it can start the next operation at that position.

(Note 1) When the actuator is connected to the simple absolute type controller, the model is considered an incremental model.

(Note 2) It can not be used for the linear servo type.

(Note 3) Not applicable for the DSEP.

When mounting the absolute battery unit, mount it below the SEP controller to prevent heat damage.

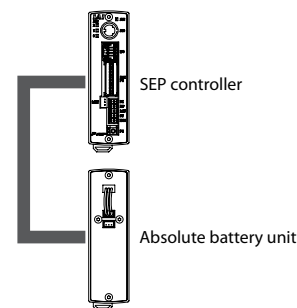

4 Pushing and intermediate stop operation is available.

Like air cylinders, the pushing operation is available. In this operation, you can stop with the rod being pushed to a workpiece.

Since the force for the push operation is adjustable within a range between 20 to 70 % of the maximum pushing force and a signal is generated when it reaches the specified pushing force, it can be used to perform such tasks as clamping the workpiece or determine its size.

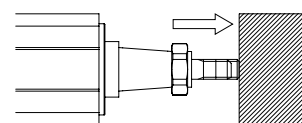

Push force can be adjusted from 20 to 70% of the maximum push force.

5 Easy data entry with the dedicated touch panel teaching unit.

Data, such as setting target positions or pushing force, are easily entered with the optional touch panel teaching unit model: CON-PTA-C-ENG.

Since the touch panel teaching unit provides an interactive menu and can be controlled directly on the screen, you can operate intuitively with no assistance from operation manuals.



Model List

Series	PSEP				ASEP				DSEP	
	C		CW		C		CW		C	CW
Name	Standard type		Dustproof type		Standard type		Dustproof type		Standard type	Dustproof type
Positioning method	Incremental encoder	Simple absolute type	Incremental encoder	Simple absolute type	Incremental encoder	Simple absolute type	Incremental encoder	Simple absolute type	Incremental encoder	Incremental encoder
External View										
Description	Position controller, for pulse motors, specialized to 2 positions / 3 positions positioning and easier control		PSEP-C dustproof type with an IP53 equivalent protection structure		Position controller, for servo motors, specialized to 2 positions / 3 positions positioning and easier control		ASEP-C dustproof type with an IP53 equivalent protection structure		Position controller, for the RCD actuator, specialized to 2 positions / 3 positions positioning and easier control	DSEP-C dustproof type with an IP53 equivalent protection structure
Number of positions	2 positions / 3 positions									
Standard price	—									

Model

PSEP — [] — [] — **I** — [] — [] — **0** — [] — []

Series: C Standard, CW Dustproof Type

Motor type: I Incremental

I/O type: NP NPN type, PN PNP type

I/O cable length: 0 No cable, 2 2m, 3 3m, 5 5m

Power supply voltage: 0 DC24V

Simple absolute compatible: ABUM Simple absolute type (with absolute battery unit), ABUMN Simple absolute type (without absolute battery unit), (Blank) Incremental type

High acceleration compatible model: Blank Standard, H High acceleration compatible model

* Enter "H" when connecting with the RCP3-SA4C/SA5C/SA6C or RCP2 (RCP2CR)-SA5C/SA6C that are high acceleration compatible models.

20P	20□ pulse motor compatible
20SP	20□ pulse motor compatible RCP3-RA2 high-thrust type only)
28P	28□ pulse motor compatible
28SP	28□ pulse motor compatible (RA3C only)
35P	35□ pulse motor compatible
42P	42□ pulse motor compatible
56P	56□ pulse motor compatible

ASEP — [] — [] — **I** — [] — [] — [] — **0** — [] — []

Series: C Standard, CW Dustproof Type

Motor type: I Incremental

Option: HA High-acceleration specification, LA Power-saving specification

I/O type: NP NPN type, PN PNP type

I/O cable length: 0 No cable, 2 2m, 3 3m, 5 5m

Power supply voltage: 0 DC24V

Simple absolute compatible: ABUM Simple absolute type (with absolute battery unit), ABUMN Simple absolute type (without absolute battery unit), (Blank) Incremental type

2	2W motor compatible
5	5W motor compatible
5S	5W motor compatible (SA2A□, RA2A□ only)
10	10W motor compatible
20	20W motor compatible
20S	20W motor compatible (RCA2-SA4□/TA5□, RCA-RA3□ only)
30	30W motor compatible

DSEP — [] — **3** — **I** — [] — [] — **0**

Series: C Standard type, CW Dustproof type

Motor type: 3 DC brushless 2.5W Motors

Encoder type: I Incremental Type

I/O type: NP NPN type, PN PNP type

I/O cable length: 0 Without cable, 2 2m, 3 3m, 5 5m

Power supply voltage: 0 DC24V

System Configuration

<PSEP>

Option

PC software
(See P559)
RS232 connection version
<Model: RCM-101-MW>
USB connection version
<Model: RCM-101-USB>
* The cable comes with the
PC software.
* Versions older than
7.00.01.00 cannot be used
with PSEP controller.

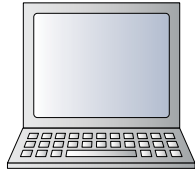

Standard cable 5m

Supplied with the PC software

Connection cable standard 0.5m

Supplied with the absolute battery unit



Supplied with the simple absolute type

Absolute battery unit for SEP controller
(See P560)
<Model: SEP-ABUM> (standard)
<Model: SEP-ABUM-W> (for dustproof)

Supplied with the actuator

Motor-encoder integrated robot cable
(See P561)
<Model CB-PSEP-MPA□□□>
Standard 1m / 3m / 5m

Actuator RCP2 series
Rotary type RCP2-RT
(See below for small rotary)
Gripper type
RCP2-GRS/GRM/GR3□□



RCP2 small rotary
(RCP2-RTBS/RTCS)
* The above models use
a dedicated cable.

Supplied with the actuator

Motor-encoder integrated robot cable
(See P562)
<Model CB-RPSEP-MPA□□□>
Standard 1m / 3m / 5m

Supplied with the actuator

Motor-encoder integrated robot cable
(See P561)
<Model CB-APSEP-MPA□□□>
Standard 1m / 3m / 5m



Actuator RCP3 series
RCP2-GRSS/GRLS/GRST
RCP2-SRA4R/SRGS4R/SRSD4R

PLC

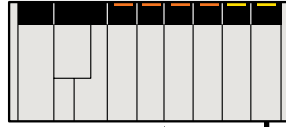

Field Network
DeviceNet/CC-Link/PROFIBUS

Supplied with Controller

PIO cable
(See P562)
<Model: CB-APSEP-PIO020> (standard)
<Model: CB-APSEPW-PIO020> (for dustproof)
Standard 2m

Option

DC24V power supply
<Model: PS-241 (100V input)>
<Model: PS-242 (200V input)>



<PCON/RPCON/PSEL>



Supplied with the actuator

Motor-encoder integrated robot cable
(See P630)
<Model CB-PCS-MPA□□□>
Standard 1m / 3m / 5m

- Controller
- PMEC AMEC
- PSEP ASEP DSEP
- MSEP
- ERC3
- ERC2
- PCON -CA
- PCON
- ACON
- SCON -CA
- MSCON
- PSEL
- ASEL
- SSEL
- XSEL
- PS-24
- Pulse Motor
- Servo Motor (24V)
- Servo Motor (200V)
- Linear Servo Motor

System configuration

<ASEP>

Option

PC software (See P559)
 RS232 connection version
 <Model: RCM-101-MW>
 USB connection version
 <Model: RCM-101-USB>
 * The cable comes with the PC software.
 * Versions older than 7.00.01.00
 cannot be used with ASEP controller.

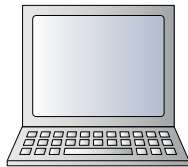

Standard cable 5m

Supplied with the PC software

Connection cable standard 0.5m

Supplied with the absolute battery unit



Supplied with the simple absolute type

Absolute battery unit for SEP controller
 (Refer to P. 560)
 <Model: SEP-ABUM> (standard)
 <Model: SEP-ABUM-W> (for dustproof)

Supplied with the actuator

Motor-encoder integrated robot cable
 (See P561)
 <Model CB-ASEP-MPA□□□>
 Standard 1m / 3m / 5m



Actuator RCA Series

Option

Teaching Pendant (See P557)
 <Model: CON-PTA/CON-PDA/CON-PGAS>
 Dedicated teaching pendant for SEP
 <Model: SEP-PT>



5m

Supplied with Controller

PIO cable
 (See P562)
 <Model: CB-APSEP-PIO020> (standard)
 <Model: CB-APSEPW-PIO020> (for dustproof)
 Standard 2m



Field Network
 DeviceNet/CC-Link/PROFIBUS

Option

DC24V power supply
 <Model: PS-241 (100V input)>
 <Model: PS-242 (200V input)>



<ACON/RACON/ASEL>



Supplied with the actuator

Motor-encoder integrated robot cable
 (See P561)
 <Model CB-ASEP-MPA□□□>
 Standard 1m / 3m / 5m



Actuator RCA2/RCL Series

Supplied with the actuator

Motor-encoder integrated robot cable
 (See P640)
 <Model CB-ACS-MPA□□□>
 Standard 1m / 3m / 5m

<DSEP>

Option

PC software (Refer to P. 559)
 RS232 connection version
 <Model: RCM-101-MW>
 USB connection version
 <Model: RCM-101-USB>
 * The cable comes with the PC software.
 * Versions older than 8.04.00.00
 cannot be used with DSEP controller.

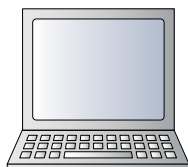

Standard cable 5m

Supplied with the PC software



Actuator RCD Series

Option

Teaching Pendant
 (See P557)
 <Model: CON-PTA/CON-PDA/CON-PGAS>
 Dedicated teaching pendant for SEP
 <Model: SEP-PT>



5m

Supplied with Controller

PIO cable
 (See P562)
 <Model: CB-APSEP-PIO020> (standard)
 <Model: CB-APSEPW-PIO020> (for dustproof)
 Standard 2m

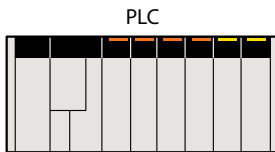

Option

DC24V power supply
 <Model: PS-241 (100V input)>
 <Model: PS-242 (200V input)>



Supplied with the actuator

Motor-encoder integrated cable (See P575)
 <Model CB-CA-MPA□□□> Standard 1m / 3m / 5m



PSEP / ASEP / DSEP



Toll Free Phone (877) SERV098
 Toll Free Fax (877) SERV099
 www.electromate.com
 sales@electromate.com

- PMEC
- AMEC
- PSEP
- ASEP
- DSEP
- MSEP
- ERC3
- ERC2
- PCON
- CA
- PCON
- ACON
- SCON
- CA
- MSCON
- PSEL
- ASEL
- SSEL
- XSEL
- PS-24

Pulse Motor

Servo Motor (24V)

Servo Motor (200V)

Linear Servo Motor

- Controller
- PMEC
AMEC
- PSEP
ASEP
DSEP
- MSEP
- ERC3
- ERC2
- PCON
-CA
- PCON
- ACON
- SCON
-CA
- MSCON
- PSEL
- ASEL
- SSEL
- XSEL
- PS-24
- Pulse Motor
- Servo Motor (24V)
- Servo Motor (200V)
- Linear Servo Motor

PIO Pattern Description

The SEP controller provides the following six PIO patterns from which you can choose for operation. Also, PIO patterns 0 to 2 support both the single solenoid and double solenoid signal configurations.

PIO pattern number		0		1		2		3		4		5	
PIO pattern name		Standard 2-position movement		Moving speed change		Position data change		2-input 3-position travel		3-input 3-position travel		Continuous cycle operation	
Feature		2-position motion		2-position motion		2-position motion		3-position motion		3-position motion		Continuous motion between 2 positions	
		Push		Push		Push		Push		Push		Push	
		—		Changing speed during motion		Motion position data change		—		—		—	
Supported solenoid configurations		Single	Double	Single	Double	Single	Double	—		—		—	
Input	0	Motion signal	Motion signal 1	Motion signal	Motion signal 1	Motion signal	Motion signal 1	Motion signal 1		Retract motion signal		Continuous operation signal	
	1	Pause signal	Motion signal 2	Pause signal	Motion signal 2	Pause signal	Motion signal 2	Motion signal 2		Extend motion signal		Pause signal	
	2	— (Reset signal)		Moving speed change signal (Reset signal)		Target position change signal (Reset signal)		— (Reset signal)		Intermediate motion signal (Reset signal)		— (Reset signal)	
	3	— /Servo-ON signal		— /Servo-ON signal		— /Servo-ON signal		— /Servo-ON signal		— /Servo-ON signal		— /Servo-ON signal	
Output	0	Retract motion output signal		Retract motion output signal		Retract motion output signal		Retract motion output signal		Retract motion output signal		Retract motion output signal	
	1	Extend motion output signal		Extend motion output signal		Extend motion output signal		Extend motion output signal		Extend motion output signal		Extend motion output signal	
	2	Homing completion signal /Servo-ON output signal		Homing completion signal /Servo-ON output signal		Homing completion signal /Servo-ON output signal		Intermediate position output signal		Intermediate position output signal		Homing completion signal /Servo-ON output signal	
	3	Alarm output signal /Servo-ON output signal		Alarm output signal /Servo-ON output signal		Alarm output signal /Servo-ON output signal		Alarm output signal /Servo-ON output signal		Alarm output signal /Servo-ON output signal		Alarm output signal /Servo-ON output signal	

*For details of the signals listed above, see the Controller User's Manual. (Can be downloaded from our corporate website.)

PIO pattern 0 (Standard 2-position travel)

This PIO pattern involves movements between two positions—the end position and the home position.

The positions can be set numerically to any position (by inputting to the controller using the PC software or the optional touch panel teaching pendant). Two motions are possible: A "positioning motion" moves the rod or the slider to the specified position, and a "pushing motion" pushes the rod against a workpiece.

Positioning motion (single solenoid)

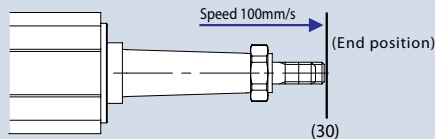

End position data	
Position	30
Speed	100
Push force	—
Width	—

Input signal

Input	Signal
Input 0	ON
Input 1	—
Input 2	—
Input 3	—

When Input 0 is turned ON, the slider/rod moves to the end position (30mm coordinate) at a speed of 100mm/s.

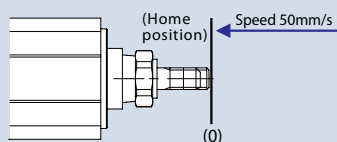

Home position data	
Position	0
Speed	50
Push force	—
Width	—

Input signal

Input	Signal
Input 0	OFF
Input 1	—
Input 2	—
Input 3	—

When input 0 is turned OFF, the slider/rod returns to the home position (0mm coordinate) at a speed of 50mm/s.

Positioning motion (double solenoid)

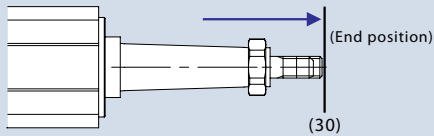

End position data	
Position	30
Speed	100
Push force	—
Width	—

Input signal

Input 0	OFF
Input 1	ON
Input 2	—
Input 3	—

When Input 1 is turned ON and Input 0 is turned OFF, the slider/rod moves to the end position (30mm coordinate) at a speed of 100mm/s.

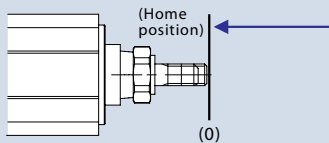

Home position data	
Position	0
Speed	50
Push force	—
Width	—

Input signal

Input 0	ON
Input 1	OFF
Input 2	—
Input 3	—

When Input 0 is turned ON and Input 1 is turned OFF, the slider/rod returns to the home position (0mm coordinate) at a speed of 50mm/s.

Push motion (single solenoid)

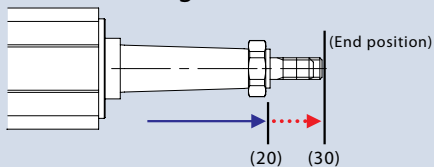

End position data	
Position	30
Speed	100
Push force	50
Width	10

Input signal

Input 0	ON
Input 1	—
Input 2	—
Input 3	—

When Input 0 is turned ON, the rod moves to the 20mm position at 100mm/s, and then starts pushing from the 20mm position to the 30mm position at slow speed.

* The pushing motion is performed only if there is a numerical value for the pushing force in the controller's position data. (If there is no numerical value for the pushing force, a positioning motion will be performed instead.)

Push motion (double solenoid)

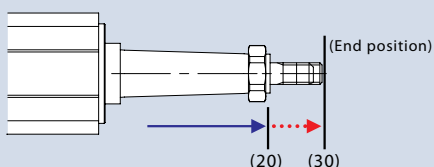

End position data	
Position	30
Speed	100
Push force	50
Width	10

Input signal

Input 0	OFF
Input 1	ON
Input 2	—
Input 3	—

When Input 1 is turned ON and Input 0 is turned OFF, the rod moves to the 20mm position at 100mm/s, and then starts pushing from the 20mm position to the 30mm position at slow speed.

* The pushing motion is performed only if there is a numerical value for the pushing force in the controller's position data. (If there is no numerical value for the pushing force, a positioning motion will be performed instead.)

PMEC
AMEC

PSEP
ASEP
DSEP

MSEP

ERC3

ERC2

PCON
-CA

PCON

ACON

SCON
-CA

MSCON

PSEL

ASEL

SSEL

XSEL

PS-24

Pulse
Motor

Servo
Motor
(24V)

Servo
Motor
(200V)

Linear
Servo
Motor

- Controller
- PMEC
AMEC
- PSEP
ASEP
DSEP
- MSEP
- ERC3
- ERC2
- PCON
-CA
- PCON
- ACON
- SCON
-CA
- MSCON
- PSEL
- ASEL
- SSEL
- XSEL
- PS-24
- Pulse Motor
- Servo Motor (24V)
- Servo Motor (200V)
- Linear Servo Motor

PIO pattern 1 (Speed Change during movement)

This PIO pattern involves movements between two positions—the end position and the home position. The speed can be changed in 2 stages. (The speed can be either increased or decreased.) The speed change occurs when the rod/slider passes the speed change position, specified in the position values.

(Single solenoid)

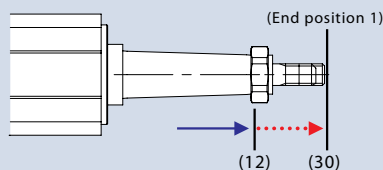
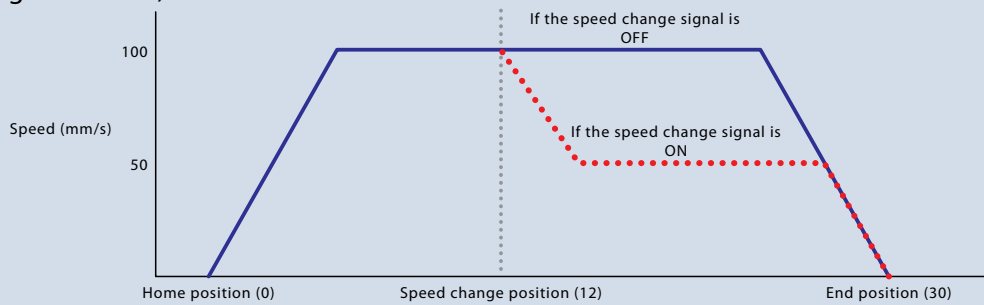

Input signal

Input 0	ON
Input 1	—
Input 2	ON
Input 3	—

When Input 0 is turned ON while Input 2 is turned ON, the rod moves at the initial speed up to the speed change position. After it passes the speed change position, the speed changes. If Input 2 is not turned ON, the speed will not change.

Home position data	
Position	0
Speed	50
Speed change position	12
Changed speed	100
Push force	—
Width	—

End position data	
Position	30
Speed	100
Speed change position	12
Changed speed	50
Push force	—
Width	—

PIO pattern 2 (position change)

This PIO pattern involves movements between two positions—the end position and the home position. You can set 2 sets of data for the end / home positions, speed, pushing force, and pushing width. Switching between the 2 sets of data can be done by turning ON/OFF Input 2, which is the signal for switching the target position.

(Single solenoid)

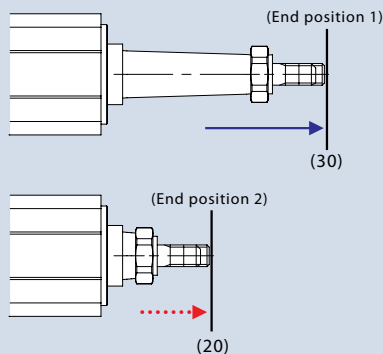
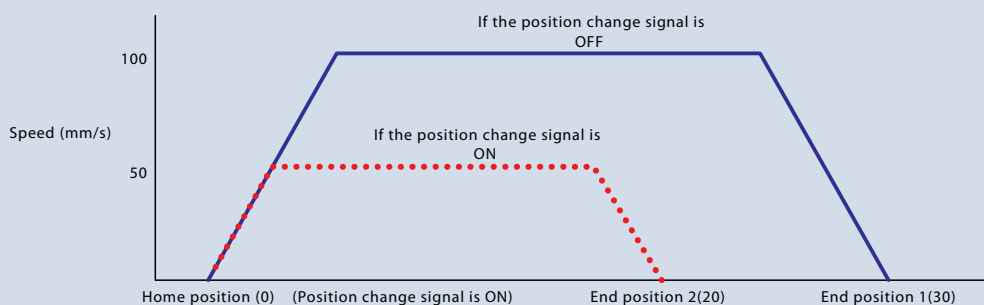

Input signal

Input 0	ON
Input 1	—
Input 2	ON
Input 3	—

If Input 2 (position change signal) is OFF when Input 0 is turned ON, the rod moves according to the position and speed set in "End Position Data 1" (position: 30 / speed: 100). If Input 2 is ON when Input 0 is turned ON, the rod's movement changes to the position and speed set in "End Position Data 2" (position: 20 / speed: 50). If Input 2 is OFF when the movement starts, but is turned ON in transit, the target position and speed is changed from that position.

End position data 1	
Position	30
Speed	100
Push force	—
Width	—

End position data 2	
Position	20
Speed	50
Push force	—
Width	—

PIO pattern 3 (2-input 3-position travel)

This PIO pattern involves movements between 3 positions—the end position, the home position, and an intermediate position. Changing between the positions is done by a combination of 2 signals, Input 0 and Input 1.

Positioning motion

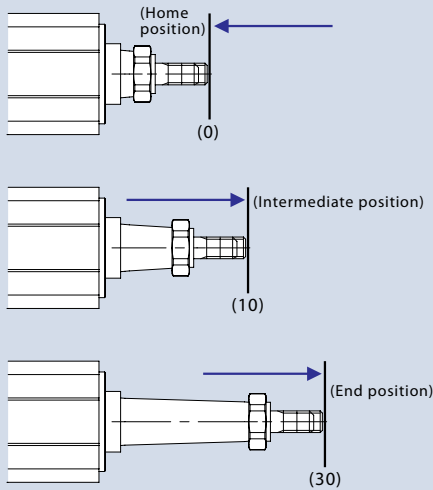

Input signal

Input 0	ON
Input 1	OFF
Input 2	—
Input 3	—

When only Input 0 is turned ON, the rod moves to the home position at the specified speed.

Input signal

Input 0	ON
Input 1	ON
Input 2	—
Input 3	—

When Input 0 and Input 1 are both turned ON, the rod moves to the intermediate position at the specified speed.

Input signal

Input 0	OFF
Input 1	ON
Input 2	—
Input 3	—

When only Input 1 is turned ON, the rod moves to the end position at the specified speed.

PIO pattern 4 (3-input 3-position travel)

This PIO pattern involves movements between 3 positions—the end position, the home position, and an intermediate position. Changing between positions is done by three signals—Input 0, Input 1 and Input 2, which are commanded to move to the home, end and intermediate positions, respectively.

Positioning motion

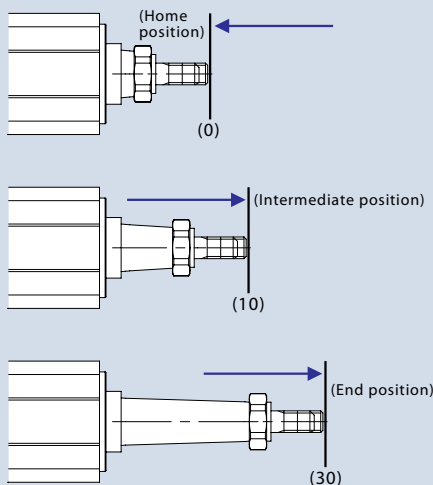

Input signal

Input 0	ON
Input 1	OFF
Input 2	OFF
Input 3	—

When Input 0 is turned ON, the rod moves to the home position at the specified speed.

Input signal

Input 0	OFF
Input 1	OFF
Input 2	ON
Input 3	—

When Input 2 is turned ON, the rod moves to the intermediate position at the specified speed.

Input signal

Input 0	OFF
Input 1	ON
Input 2	OFF
Input 3	—

When Input 1 is turned ON, the rod moves to the end position at the specified speed.

PIO pattern 5 (continuous cycle operation)

This PIO pattern involves continuous cycling between 2 positions—the end and home positions. When Input 0 (continuous operation signal) is turned ON, the rod continuously moves between the specified 2 positions. If Input 0 is turned OFF while in motion, it stops after reaching the current destination.

Positioning motion

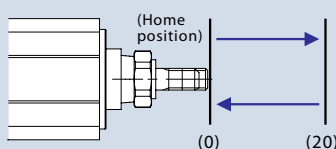

Input signal

Input 0	ON
Input 1	—
Input 2	—
Input 3	—

When Input 0 is turned ON, the rod moves continuously between the end and home positions at the specified speed.

- Controller
- PMEC
AMEC
- PSEP
ASEP
DSEP
- MSEP
- ERC3
- ERC2
- PCON
-CA
- PCON
- ACON
- SCON
-CA
- MCON
- PSEL
- ASEL
- SSEL
- XSEL
- PS-24
- Pulse
Motor
- Servo
Motor
(24V)
- Servo
Motor
(200V)
- Linear
Servo
Motor

I/O signal table

Pin No.	Cable color	PIO pattern number PIO pattern name	0		1		2		3	4	5	
			Standard 2-position travel		Speed change		Position change		2-input 3-position travel	3-input 3-position travel	Continuous cycle operation	
		Solenoid type	Single	Double	Single	Double	Single	Double	—	—	—	
1	Brown	COM	24V		24V		24V		24V	24V	24V	
2	Red	COM	0V		0V		0V		0V	0V	0V	
3	Orange	Input	0	ST0	ST0	ST0	ST0	ST0	ST0	ST0	ASTR	
4	Yellow		1	*STP	ST1(—)	*STP	ST1(—)	*STP	ST1(—)	ST1	ST1(—)	—/*STP
5	Green		2	— (RES)	SPDC (RES)	— (RES)	SPDC (RES)	— (RES)	SPDC (RES)	— (RES)	ST2 (RES)	— (RES)
6	Blue	Output	3	—/SON	—/SON	—/SON	—/SON	—/SON	—/SON	—/SON	—/SON	
7	Purple		0	LS0/PE0	LS0/PE0	LS0/PE0	LS0/PE0	LS0/PE0	LS0/PE0	LS0/PE0	LS0/PE0	
8	Gray		1	LS1/PE1	LS1/PE1	LS1/PE1	LS1/PE1	LS1/PE1	LS1/PE1	LS1/PE1	LS1/PE1	
9	White		2	HEND/SV	HEND/SV	HEND/SV	HEND/SV	HEND/SV	LS2/PE2	LS2/PE2	HEND/SV	
10	Black	3	*ALM/SV	*ALM/SV	*ALM/SV	*ALM/SV	*ALM/SV	*ALM/SV	*ALM/SV	*ALM/SV		

Note: The above signals marked with * are normally ON and turn OFF when active.

Specification table

Item	Specifications												
	PSEP		ASEP		DSEP								
Controller type	C	CW	C	CW	C	CW							
Connectable actuators	CP2/RCP3 series actuators		RCA/RCA2/RCL series actuators		RCD series actuators								
Number of control axes	1 Axis												
Operating method	Positioner type												
Number of positions	2-positions/ 3-positions (4-positions *2)												
Backup memory	EEPROM												
I/O connector	10-pin connector												
Number of I/O points	4 input points/4 output points												
I/O power supply	External supply DC24V±10%												
Dedicated type for serial communication	RS485 1ch												
Peripheral device communication cable	CB-APSEP-PIO□□□□	CB-APSEP-PW-PIO□□□□	CB-APSEP-PIO□□□□	CB-APSEP-PW-PIO□□□□	CB-APSEP-PIO□□□□	CB-APSEP-PW-PIO□□□□							
Position detection method	Incremental encoder (Attaching an absolute battery unit makes the simple absolute specification possible. *3)				Incremental encoder								
Motor-encoder cable	RCP2 connection-use	CB-PSEP-MPA□□□□		(Connection not possible)		(Connection not possible)							
	RCA connection-use	(Connection not possible)		CB-ASEP-MPA□□□□		(Connection not possible)							
	RCP3/RCA2 connection-use	CB-APSEP-MPA□□□□				(Connection not possible)							
	RCP2 small rotary connection-use	CB-RPSEP-MPA□□□□		(Connection not possible)		(Connection not possible)							
	RCD connection	(Connection not possible)				CB-CA-MPA□□□□							
Input voltage	DC24V±10%												
Control power supply capacity	0.5A (0.8A for the simple absolute specification)												
Motor power supply capacity	Motor size	Rated	Max. (*4)	Motor power output	Rated	Max	Motor power output	Rated	Max.				
	20P	0.17A	2.0A	2W	0.8A	Power-saving (*5)				Standard (*6) high acceleration/ deceleration			
				5W	1.0A	Not specified				4.6A			
	28P	0.17A	2.0A	5W	1.0A	Not specified				6.4A			
				5W□RCA2-SA2□□□□	1.0A	Not specified				2.0A			
	35P	0.9A	2.0A	10W□RCL□□□□	1.3A	Not specified				6.4A	3W	0.7A	1.5A
	42P	0.9A	2.0A	10W□RCA□RCA2□□□□	1.3A	2.5A				4.4A			
56P	0.9A	2.0A	20W	1.3A	2.5A	4.4A							
—	—	—	20W□20S□□□□□□□□	1.7A	3.4A	5.1A							
—	—	—	30W	1.3A	2.2A	4.4A							
Inrush current (*1)	Max.10A												
Amount of heat generated	8.4W		9.6W		4W								
Dielectric strength voltage	DC500V 1MΩ												
Vibration resistance	XYZ direction 10~57Hz One-side width 0.035mm (continuous), 0.075mm (intermittent) 58~150Hz 4.9m/s ² (continuous), 9.8m/s ² (intermittent)												
Ambient operating temperature	0 to 40°C												
Ambient operating humidity	10~85% RH (non-condensing)												
Ambient operating atmosphere	Free from corrosive gases												
Protection Class	IP20	IP53 (*7)	IP20	IP53 (*7)	IP20	IP53 (*7)							
Weight	Approx. 130g	Approx. 160g	Approx. 130g	Approx. 160g	Approx. 130g	Approx. 160g							

(*1) Upon power-ON, an electrical current of 5 to 12 times as much as the rated current, called "inrush current" flows for 1 to 2 ms. Note that the amount of inrush current varies based on the impedance of power source lines.

(*2) This applies to the case where two position data points are set at each of the end and home positions during a "position change" motion pattern process.

(*3) The simple absolute type controllers cannot be used for the linear servo type.

(*4) After the motor power has been turned on, the motor is excited and it performs a phase detection operation. During this time, the current will be maximized. (Generally for about 100ms)

However, if after the motor power is off, it is turned on again, approximately 6.0A current will flow. (For approximately 1~2 ms)

(*5) The current will be maximized when the motor is excited and it performs a phase detection operation or during a collision or a motion constraint. The phase detection operation can take up to 10 seconds during which it is necessary to require the listed current.

(*6) The current will be maximized during acceleration, deceleration, a collision, or a motion constraint. The longest time will be during a collision or a motion constraint. The listed current is required until an overload is detected.

(*7) The bottom surface is excluded.

555

PSEP / ASEP / DSEP

Names

PSEP, ASEP, DSEP Incremental type

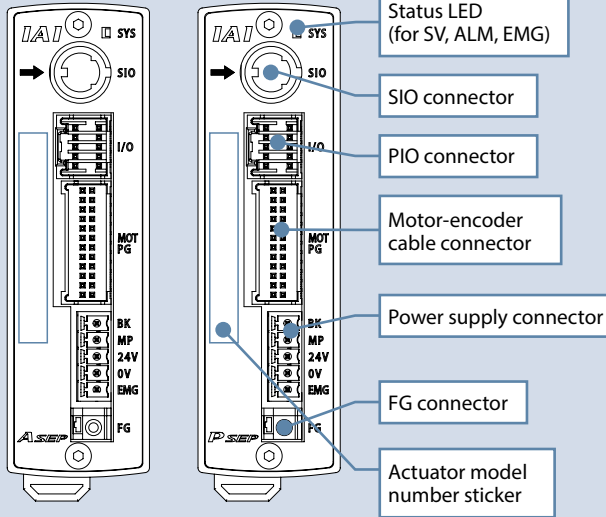

PSEP, ASEP Simple absolute type

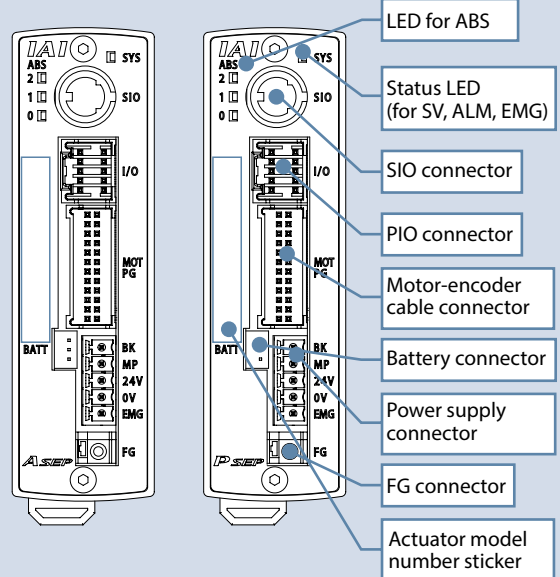

External dimensions

Standard type

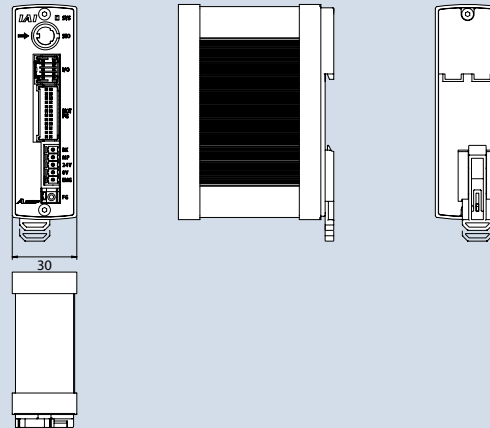
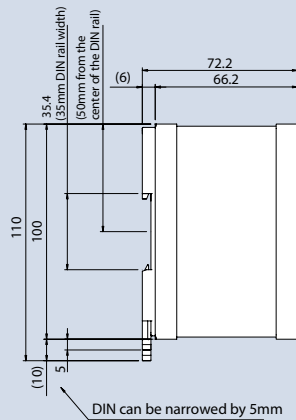

Dustproof type

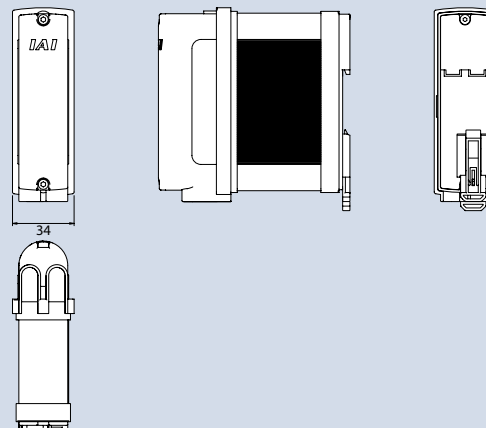
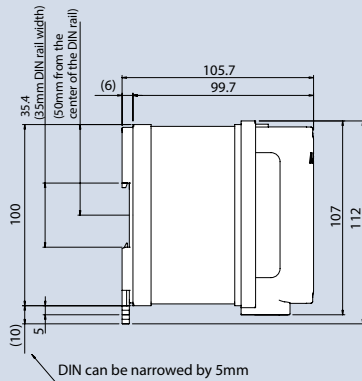

PMEC
AMEC

PSEP
ASEP
DSEP

MSEP

ERC3

ERC2

PCON
-CA

PCON

ACON

SCON
-CA

MSCON

PSEL

ASEL

SSEL

XSEL

PS-24

Pulse
Motor

Servo
Motor
(24V)

Servo
Motor
(200V)

Linear
Servo
Motor

- Controller
- PMEC
AMEC
- PSEP
ASEP
DSEP
- MSEP
- ERC3
- ERC2
- PCON
-CA
- PCON
- ACON
- SCON
-CA
- MSCON
- PSEL
- ASEL
- SSEL
- XSEL
- PS-24
- Pulse Motor
- Servo Motor (24V)
- Servo Motor (200V)
- Linear Servo Motor

Options

Touch-panel Teaching Pendant for Position Controller CON-PTA/PDA/PGAS

Adopting an easy-to-use interactive touch-panel menu screen, these simple data devices can be operated without consulting to the manuals.



1. Color screen for greater ease of view
2. Supporting the takt time minimization function and maintenance information checking/input functions.
3. Position, parameters and other data can be saved in a SD card
4. Built-in clock function records the date & time of each event; data can then be saved in a SD card.

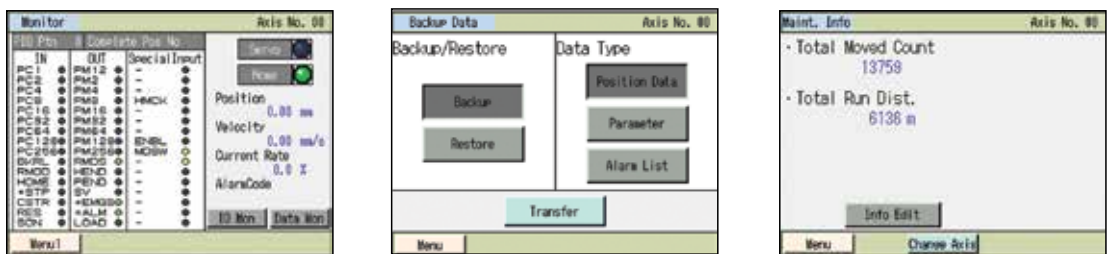

Model Numbers/Specifications

Item	Description		
Model number	CON-PTA-C-ENG	CON-PDA-C-ENG	CON-PGAS-C-S-ENG (set)
Type	Standard type	Enable switch type	Safety-category compliant type
Connectable controllers	ACON/PCON/SCON/RACON/RPCON/MSCON/ASEP/PSEP/MSEP/DSEP/AMEC/PMEC /ERC2 (*1) /ERC3		
3-position enable switch	×	○	○
Functions	<ul style="list-style-type: none"> • Position data input/editing • Moving function (moving to set positions, jogging/inching) • Parameter editing • Monitoring (current position, current speed, I/O signals, alarm code, alarm generation time) • Saving/reading data to/from external SD cards (position data parameters, alarm list) • Takt time minimization function • Maintenance information (total number of movements, total distance travelled, etc.) 		
Display	65,536 colors (16-bit colors), white LED backlight		
Ambient operating temperature/humidity	0 to 40°C, 85% RH or less (Non-condensing)		
Environmental resistance	IP40 or equivalent		
Mass	Approx. 570g	Approx. 600g	
Cable length	5m		
Accessories	Stylus	Stylus	Stylus, TP adapter (Model number: RCB-LB-TGS) Dummy plug (Model number: DP-4S) Controller cable (Model number: CB-CON-LB005)
Standard price	—	—	—

*1 Among the ERC2 series, only the actuators bearing 4904 or greater number stamped on the serial number label can be connected.

Name of each part/Outer dimensions

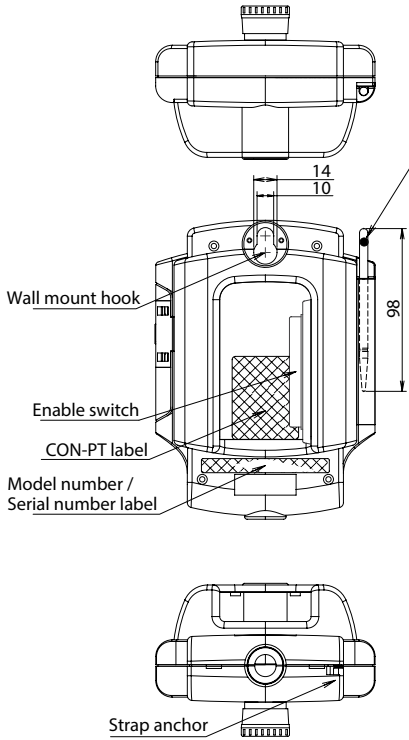

Option

•Strap

MODEL STR-1

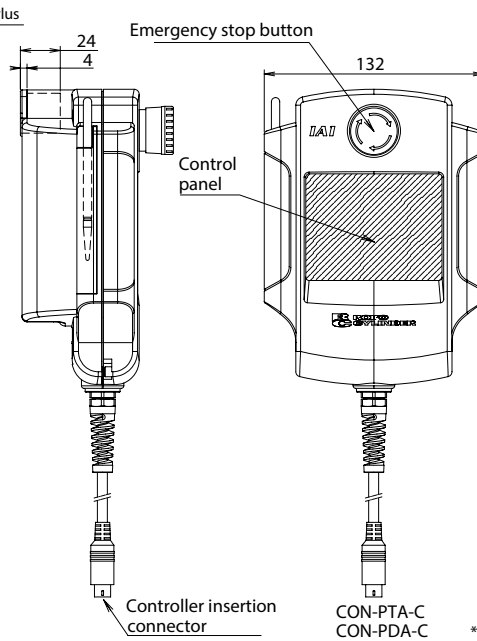

CON-PTA-C
CON-PDA-C

CON-PGAS-C

* Please note that the CON-PGAS-C has a controller insertion connector that is different from the other models.

Wiring Diagram of CON-PGAS-C-S

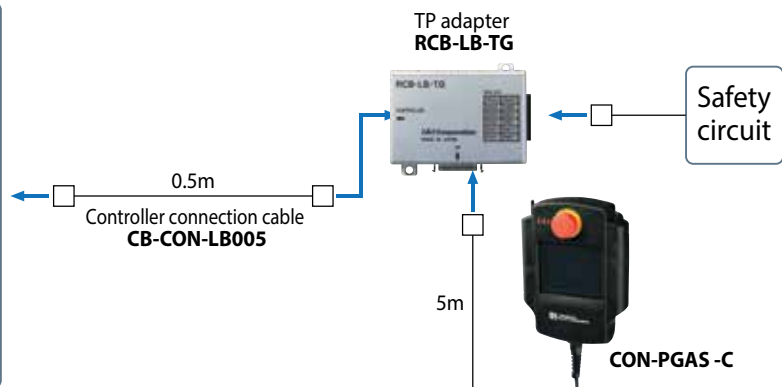
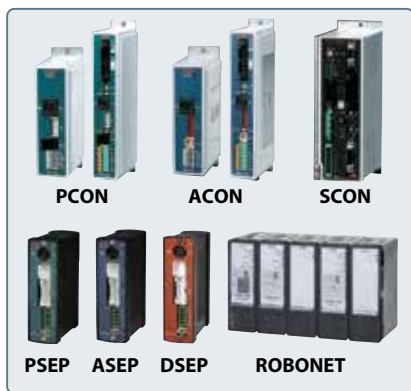

Option

PC software (Windows only)

Features

This startup support software provides functions to input positions, perform test operations and monitor data, among others. Incorporating all functions needed to make adjustments, this software helps shorten the initial startup time.

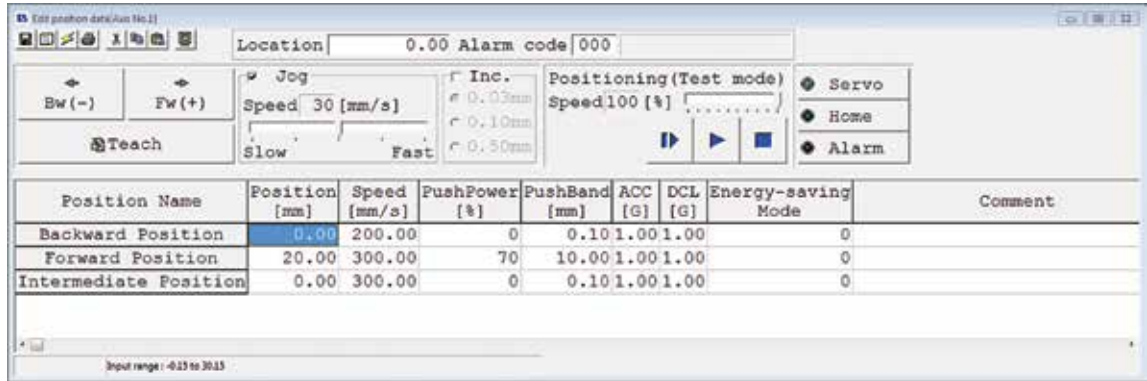

Supported Windows OS: 2000 SP4 or later / XP SP2 or later / Vista / 7

Model

RCM-101-MW

(With external equipment communication + RS232 conversion unit)

Configuration

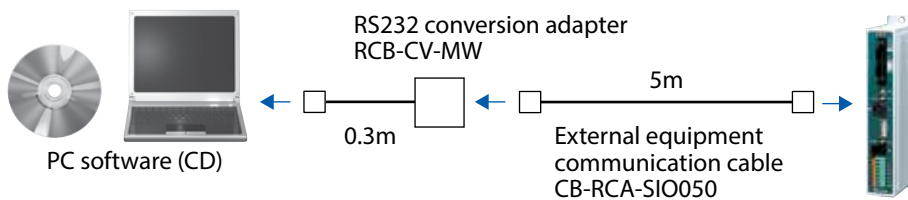

Model

RCM-101-USB

(With external equipment communication + USB conversion adapter + USB cable)

Configuration

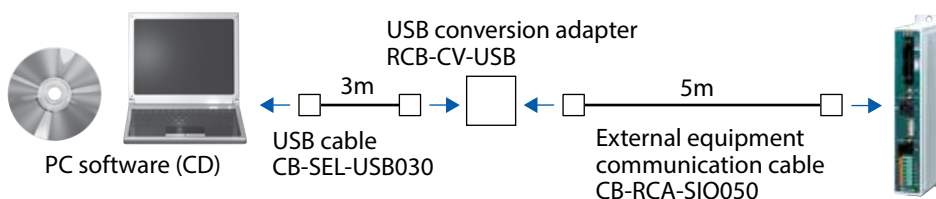

Absolute battery unit for SEP controllers

Description Supplied with the PSEP and ASEP simple absolute controllers. This is a battery unit used for backing up the current position data.

Note:
There is no simple absolute type DSEP.

Model **SEP-ABUM** (standard type)
SEP-ABUM-W (dustproof type)

Specifications

Item	Specifications			
Ambient operating temperature and humidity	0 to 40°C (about 20°C preferred), 95% RH or below (non-condensing)			
Ambient operating environment	Free from corrosive gases			
Absolute battery (*1)	Model: AB-7(Ni-MH battery/approx. 3-year life)			
Controller-absolute battery unit cable (*1)	Model: CB-APSEP-ABM005 (length 0.5m)			
Weight	Standard type: approx. 230g / Dustproof type: approx. 260g			
Allowable encoder RPM during data retention (*2)	800rpm	400rpm	200rpm	100rpm
Position data retention time (*2)	120h	240h	360h	480h

(*1) The absolute battery unit comes with a cable to connect the controller and the absolute battery unit.

(*2) Position data retention time changes with the allowable encoder RPMs during data retention.
(800rpm→120h, 400rpm→240h, 200rpm→360h, 100rpm→480h)

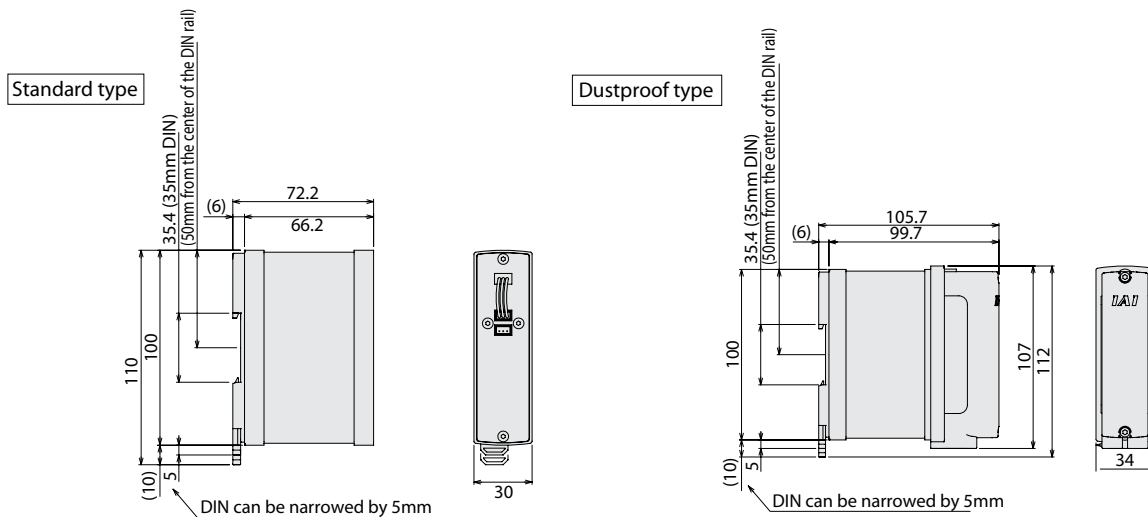

Precautions related to controllers and options:

- When mounting the controller to a DIN rail, use the supplied spacer between the controllers to prevent them from contacting each other, to deal with heat dissipation. (See Fig. 1)
- When mounting the absolute battery units and controllers, place the absolute battery units below the controllers. (See Fig. 2) If there is not enough space below the controllers, mount the absolute battery units in such a way that the temperature around the controllers stays at 40°C or below.

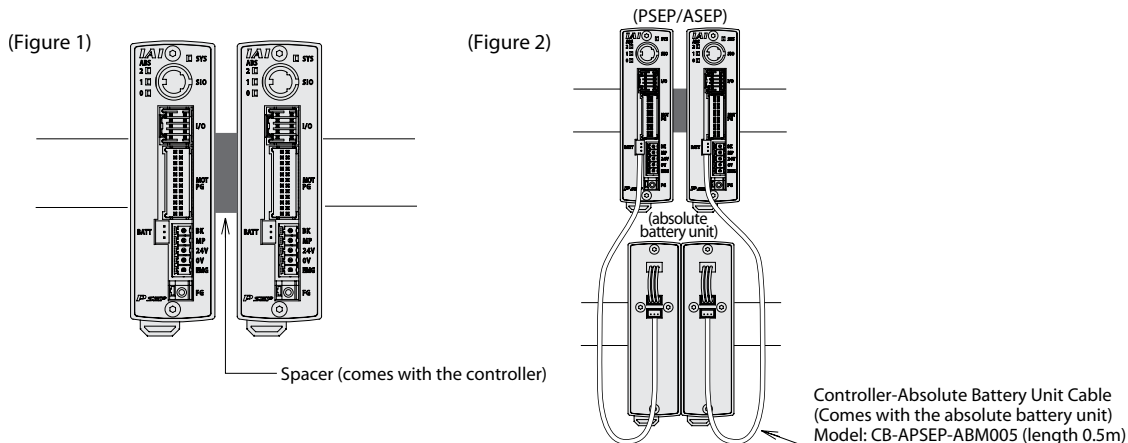

Components for Maintenance

Please refer to the models listed below when arrangements such as cable replacement are needed after purchasing the product.

[RCP3/RCA2/RCL]-[PSEP/ASEP] / Integrated motor-encoder robot cable for indirect connection / Integrated motor-encoder robot cable

Model **CB-APSEP-MPA** [] [] [] / **CB-APSEP-MPA** [] [] [] -**LC** * [] [] [] indicated the cable length (L) Lengths up to 20m can be specified Example 080=8m

*Refer to page A-59 for connectable actuators.

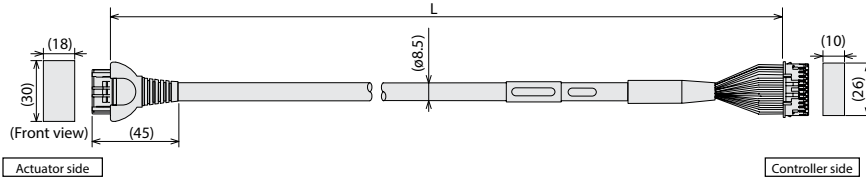

Minimum bend radius r = 68mm or larger (when movable unit is used)

Actuator side Pin number	[PCON](ACON) Color [Signal]	Controller side Pin number
A1	Black [øA](U)	1
B1	White [VMM](V)	2
A2	Brown [ø/A](W)	5
B2	Green [øB](-)	3
A3	Yellow [VMM](-)	4
B3	Red [ø/B](-)	6
A4	Orange [LS+](BK+)	7
B4	Gray [LS-](BK-)	8
A6	White [-](A+)	11
B6	Yellow [-](A-)	12
A7	Red [A+](B+)	13
B7	Green [A-](B-)	14
A8	Black [B+](Z+)	15
B8	Brown [B-](Z-)	16
A5	Black (label)[BK+](LS+)	9
B5	Brown (label)[BK-](LS-)	10
A9	Green (label)[GND](S)	20
B9	Red (label)VPS	18
A10	White (label)VCC	17
B10	Yellow (label)GND	19
A11	NC	21
B11	Shield FG	24
	NC	22
	NC	23

[RCP2]-[PSEP] Integrated motor-encoder robot cable for indirect connection

Model **CB-PSEP-MPA** [] [] [] * Robot cable is the standard specification. * [] [] [] indicated the cable length (L) Lengths up to 20m can be specified Example 080=8m

*Refer to page A-59 for connectable actuators.

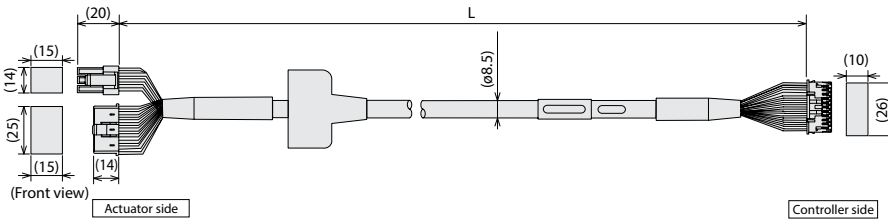

Minimum bend radius r = 68mm or larger (when movable unit is used)

Actuator side Pin number	Color [Signal]	Controller side Pin number
1	Black [øA]	1
2	White [VMM]	2
4	Red [øB]	3
5	Green [VMM]	4
3	Brown [ø/A]	5
6	Yellow [ø/B]	6
16	Orange [BK+]	9
17	Gray [BK-]	10
5	NC	11
6	NC	12
13	Black [LS+]	7
14	Brown [LS-]	8
1	White [A+]	13
2	Yellow [A-]	14
3	Red [B+]	15
4	Green [B-]	16
10	White (label)[VCC]	17
11	Yellow (label)[VPS]	18
9	Red (label)[GND]	19
12	Green (label)[Spare]	20
15	NC	21
7	NC	22
8	NC	23
18	Shield [FG]	24

[RCA]-[ASEP] Integrated motor-encoder robot cable for indirect connection

Model **CB-ASEP-MPA** [] [] [] * Robot cable is the standard specification. * [] [] [] indicated the cable length (L) Lengths up to 20m can be specified Example 080=8m

*Refer to page A-59 for connectable actuators.

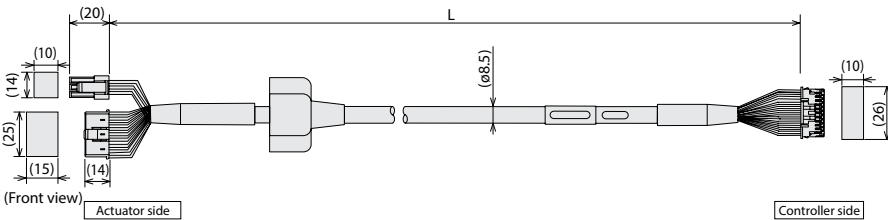

Minimum bend radius r = 68mm or larger (when movable unit is used)

Actuator side Pin number	Color [Signal]	Controller side Pin number
1	Red [U]	1
2	Yellow [V]	2
-	NC	3
-	NC	4
-	Black [W]	5
-	NC	6
18	Orange [BK+]	7
17	Gray [BK-]	8
7	Black [LS+]	9
16	Brown [LS-]	10
1	White [A+]	11
2	Yellow [A-]	12
3	Red [B+]	13
4	Green [B-]	14
10	Black (label)[Z+]	15
11	Brown (label)[Z-]	16
14	White (label)[VCC]	17
13	Yellow (label)[VPS]	18
15	Red (label)[GND]	19
6	Green (label)[Spare]	20
5	NC	21
8	NC	22
12	NC	23
9	Shield [FG]	24

[RCP2 small rotary]-[PSEP] Integrated motor-encoder robot cable for indirect connection

Model **CB-RPSEP-MPA** * Robot cable is the standard specification. indicated the cable length (L) Lengths up to 20m can be specified Example 080=8m

*Refer to page A-59 for connectable actuators.

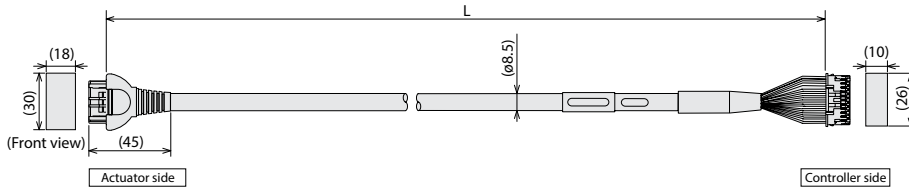

Actuator side Pin number	Color	Controller side Pin number
A1	Black [øA]	1
B1	White [VMM]	2
A2	Brown [ø/A]	5
B2	Green [øB]	3
A3	Yellow [VMM]	4
B3	Red [ø/B]	6
A6	Orange [LS+]	7
B6	Gray [LS-]	8
A7	Red [A+]	13
B7	Green [A-]	14
A8	Black [B+]	15
B8	Brown [B-]	16
A4	NC	7
B4	NC	8
A5	Black (label)[BK+]	9
B5	Brown (label)[BK-]	10
A9	Green (label)[GNDLS]	20
B9	Red (label)[VPS]	18
A10	White (label)[VCC]	17
B10	Yellow (label)[GND]	19
A11	NC	21
B11	Shield FG	24
	NC	22
	NC	23

Minimum bend radius r = 68mm or larger (when movable unit is used)

[RCD]-[DSEP] Integrated motor-encoder cable for indirect connection/ Integrated motor-encoder robot cable

Model **CB-CA-MPA** / **CB-CA-MPA** -**RB** indicated the cable length (L) Lengths up to 20m can be specified Example 080=8m

*Refer to page A-59 for connectable actuators.

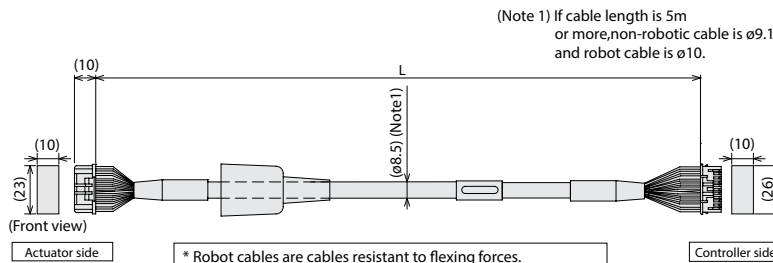

Actuator end 1-1827863-1 (AMP)			Controller end PADP-24V-1-S (JST)		
Pin No.	Signal name	Color	Pin No.	Signal name	Color
A1	0A/U	Blue(Black)	1	0A/U	Blue(Black)
B1	VMM/V	Orange(White)	2	VMM/V	Orange(White)
A2	ø A/W	Green(Brown)	5	ø A/W	Green(Brown)
B2	øB/-	Brown(Green)	3	øB/-	Brown(Green)
A3	VMM/-	Gray(Yellow)	4	VMM/-	Gray(Yellow)
B3	ø B/-	Red(Red)	6	ø B/-	Red(Red)
A4	LS+/BK+	Black(Orange)	7	LS+/BK+	Black(Orange)
B4	LS-/BK-	Yellow(Gray)	8	LS-/BK-	Yellow(Gray)
A6	-/A+	Blue(White)	11	-/A+	Blue(White)
B6	-/A-	Orange(Yellow)	12	-/A-	Orange(Yellow)
A7	A+/B+	Green(Red)	13	A+/B+	Green(Red)
B7	A-/B-	Brown(Green)	14	A-/B-	Brown(Green)
A8	B+/Z+	Gray(Black)	15	B+/Z+	Gray(Black)
B8	B-/Z-	Red(Brown)	16	B-/Z-	Red(Brown)
A5	BK+/LS+	Blue(Black)	9	BK+/LS+	Blue(Black)
B5	BK-/LS-	Orange(Brown)	10	BK-/LS-	Orange(Brown)
A9	LS GND	Green(Green)	20	LS GND	Green(Green)
B9	VPS	Brown(Red)	18	VPS	Brown(Red)
A10	VCC	Gray(White)	17	VCC	Gray(White)
B10	GND	Red(Yellow)	19	GND	Red(Yellow)
A11	-	-	21	-	-
B11	FG	Black(-)	22	-	-
			23	-	-
			24	FG	Black(-)

Minimum bend radius r = 68mm or larger (when movable unit is used)

I/O cable for PSEP-C/ASEP-C/DSEP-C

Model **CB-APSEP-PIO** indicated the cable length (L) Lengths up to 10m can be specified Example 080=8m

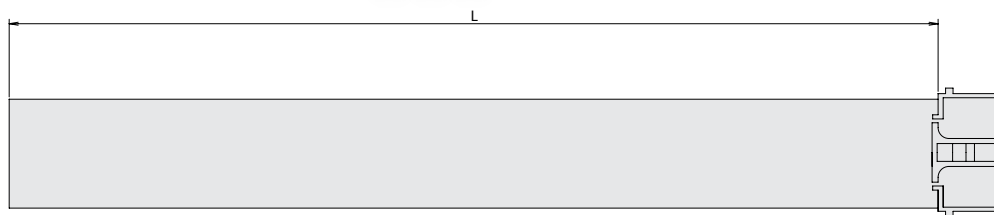

No.	Signal	Color	Wiring
1	24V	Brown	Flat Cable (crimped)
2	0V	Red	
3	IN0	Orange	
4	IN1	Yellow	
5	IN2	Green	
6	IN3	Blue	
7	OUT0	Purple	
8	OUT1	Gray	
9	OUT2	White	
10	OUT3	Black	

I/O cable for PSEP-CW/ASEP-CW /DSEP-CW

Model **CB-APSEPW-PIO** indicated the cable length (L) Lengths up to 10m can be specified Example 080=8m

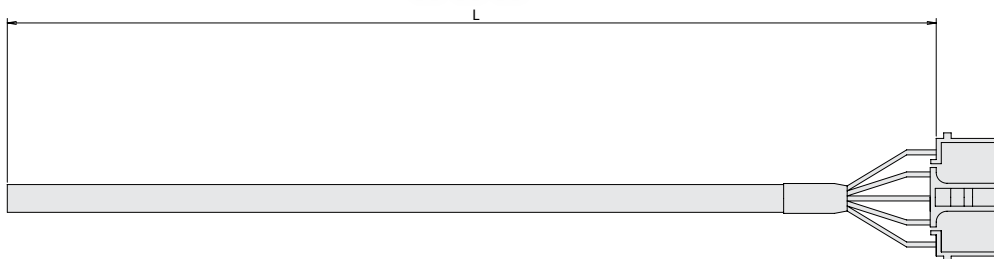

No.	Signal	Color	Wiring
1	24V	Brown	Cable (crimped)
2	0V	Brown-White	
3	IN0	Red	
4	IN1	Red-White	
5	IN2	Yellow	
6	IN3	Yellow-White	
7	OUT0	Green	
8	OUT1	Green-White	
9	OUT2	Black	
10	OUT3	Black-White	

- Controller
- PMEC
AMEC
- PSEP
ASEP
DSEP
- MSEP
- ERC3
- ERC2
- PCON
-CA
- PCON
- ACON
- SCON
-CA
- MSCON
- PSEL
- ASEL
- SSEL
- XSEL
- PS-24
- Pulse Motor
- Servo Motor (24V)
- Servo Motor (200V)
- Linear Servo Motor

MSEP

Position controller
SEP series 8-axis type



Features

1 Compact Design

A successfully designed 8-axis compact controller with a 123 mm width x 115 mm height unit. A 60% reduction in width from the predecessor controller which contributes to space savings within the controller cabinet.

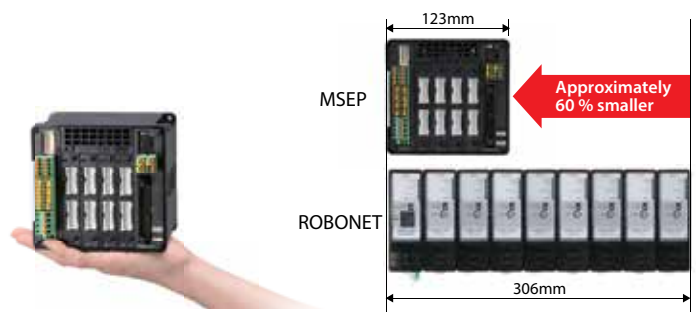

2 Supports major field networks

Allows direct connection with the major field networks including DeviceNet, CC-Link, PROFIBUS-DP, CompoNet, EtherCAT, and EtherNet/IP.

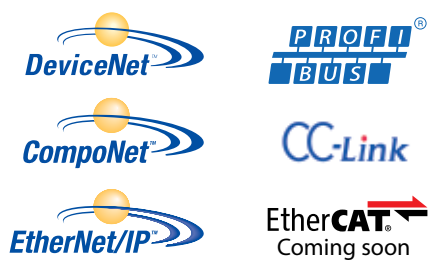

Network Specification Features

- 256 positioning points per each axis
- Allows designation of position and speed navigation numerically.
- Ability to verify current position in real-time.
- Significant communication time reduction within the controller (Approximately by 1/10 compared to the predecessor model).

3 Supports major field networks

A single MSEP controller can operate both the pulse motor and the servo motor type actuators, reducing set-up efforts significantly such as wiring even when different types of actuators have to be used at the same time.

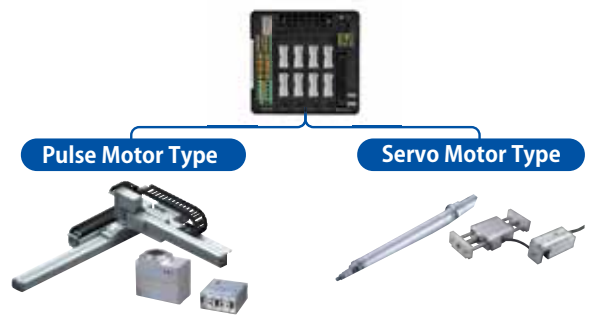

4 Simple absolute option

An absolute position encoder is available, which saves the position data by battery, providing prompt operation without returning to the home position after power off. Even in an emergency shut-off or momentary power-loss, it allows continuous operation from its last position.

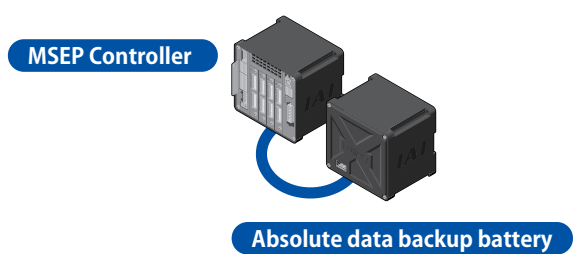

563

MSEP

Model List

Type	C							
I/O category	NP	PN	DV	CC	PR	CN	EC	EP
Item name	PIO specification (NPN type)	PIO specification (PNP type)	DeviceNet Specification	CC-Link Specification	PROFIBUS-DP Specification	CompoNet Specification	EtherCAT Specification	EtherNet/IP Specification
Exterior view	 <p>* The picture shown is of the PIO specification. Depending on the I/O category, the PIO connector and field network joint connector changes.</p>							
Item description	Operates via digital signals from the PLC		Operates with any of the above field network connections. A choice of method either a serial communication with PIO specification control, or transmitting traveling position, velocity and acceleration by data is available.					
No. of positions	3 positions per axis		256 positions per axis (There is no limit if operated directly by transferring data)					
Standard price	—							

Model

* Representation of the 2nd to the 8th axis is depending on the total number of axes applied. (i.e. after the 2nd axis)

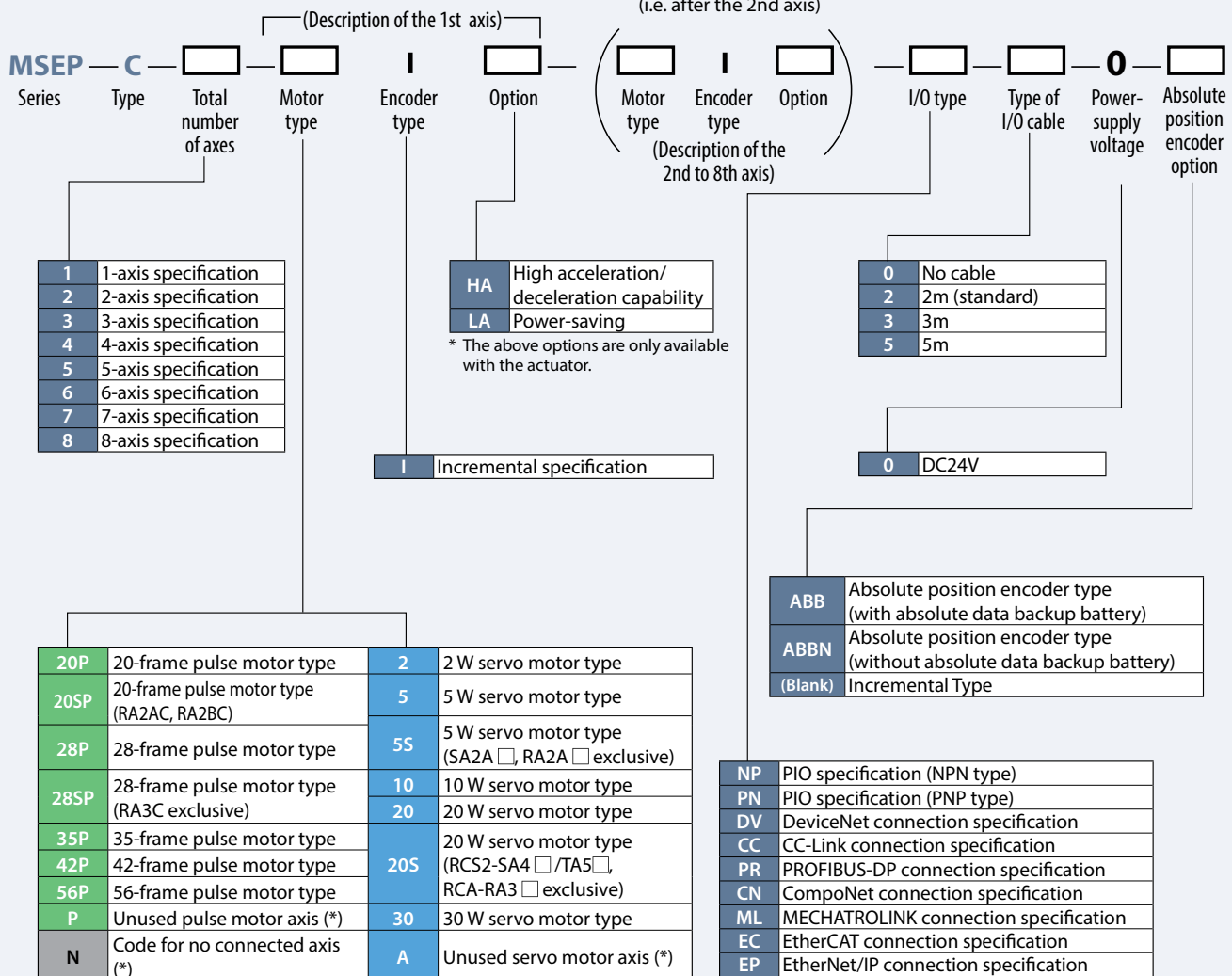

(*) Please refer to the instruction for completing selected model description on the following page.

Note) EC specifications will be available soon.

Guide for the description of the selected configuration

The description of the MSEP controller configuration varies depending on the type of actuator connected to the controller, and the total number of axes installed. Please see the following conditions to configure a desired controller.

Connect the **SAME TYPE** of actuators (either pulse motor type or servo motor type)

Connect a **MIXTURE OF TYPES** of actuators (both pulse motor type and servo motor type)

Please indicate the motor type code of the actuator starting from the 1st axis respectively.

Each board is designed to connect to a pair of axes, and two different types of motors cannot be connected to the same board. Please indicate the same types of motors for each pair of axes.

e.g.) MSEP — C — 4 — 42PI — 56PI — 42PI — 56PI — NP — 2 — 0

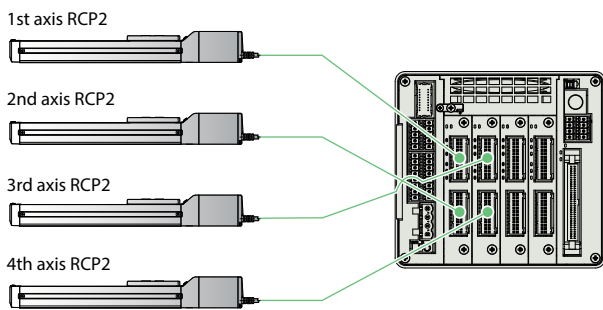
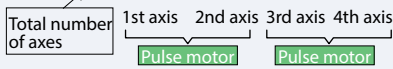

If the total number of axes is an odd count, please indicate an [N] following the last axis description (as shown after the 3rd axis below for example).

e.g.) MSEP — C — 3 — 42PI — 56PI — 42PI — N — NP — 2 — 0

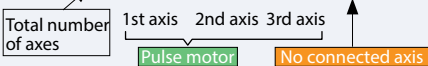

e.g.) MSEP — C — 4 — 42PI — 56PI — 20I — 20I — NP — 2 — 0

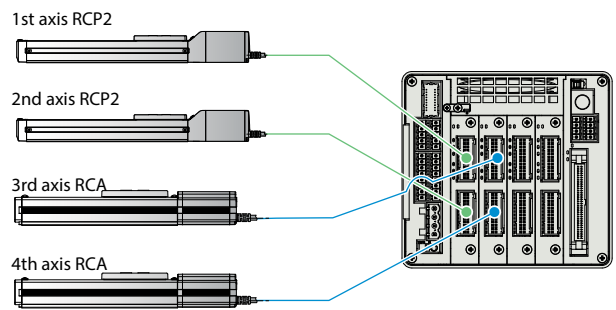
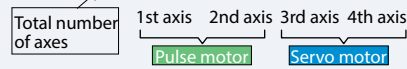

If either motor type is an odd count, please indicate an [N] following the last axis description per the corresponding board.

e.g.) MSEP — C — 3 — 42PI — N — 20SI — 30I — NP — 2 — 0

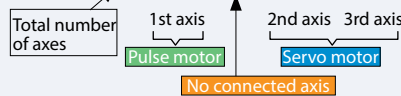

<If you choose to operate the controller with fewer axes connections now but may add more in the future>

- If there's a possibility to increase connections, for example, to 6 or 8 axes in the future but would like to start with only 4 axes to operate the controller now, it is possible to keep the base board installed as is and leave room for the potential axes by indicating an [UNUSED AXIS].
- When configuring unused axis/axes for the pulse motor, please indicate a [P] in the box for the motor type.
- When configuring unused axis/axes for the servo motor, please indicate an [A] in the box for the motor type.
- When configuring unused axis/axes, please include number of unused axis/axes in the total number of axes.

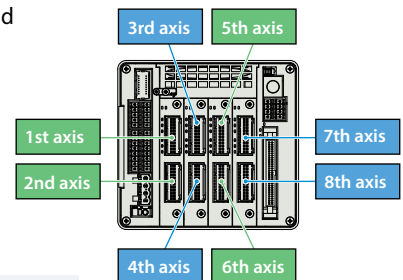

e.g.) MSEP — C — 8 — 42PI — 56PI — 20I — 10I — PI — PI — AI — AI — NP — 2 — 0

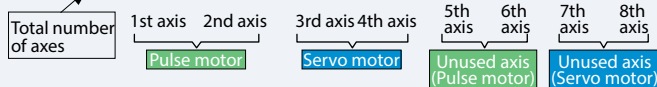

Actuator combination patterns for the MSEP

There are 40 combination patterns of the pulse motor type or the servo motor type actuator that can be connected to the MSEP controller as shown in the table below.

(all * are an incremental specification)

(The boxes in the configuration lines are to indicate the type of motor code number)

<Connectable actuators>

Pulse	Servo
Pulse motor type actuator • RCP4 series (*) • RCP3 series • RCP2 series	Servo motor type actuator • RCA2 series (*) • RCA series • RCL series

(*) High-output motion is not available

1-axis to 5-axis specification

Total number of axes	Driver slot 0		Driver slot 1		Driver slot 2		Driver slot 3		Configuration	Pattern No	Unit price Incremental specification PIO specification
	AX0	AX1	AX2	AX3	AX4	AX5	AX6	AX7			
1-axis specification	Pulse	N							MSEP-C-1-□PI-N-(*)	1	—
	Servo	N							MSEP-C-1-□I-N-(*)	2	—
2-axis specification	Pulse	Pulse							MSEP-C-2-□PI-□PI-(*)	3	—
	Pulse	N	Servo	N					MSEP-C-2-□PI-N-□I-N-(*)	4	—
	Servo	Servo							MSEP-C-2-□I-□I-(*)	5	—
3-axis specification	Pulse	Pulse	Pulse	N					MSEP-C-3-□PI-□PI-□PI-N-(*)	6	—
	Pulse	Pulse	Servo	N					MSEP-C-3-□PI-□PI-□I-N-(*)	7	—
	Pulse	N	Servo	Servo					MSEP-C-3-□PI-N-□I-□I-(*)	8	—
	Servo	Servo	Servo	N					MSEP-C-3-□I-□I-□I-N-(*)	9	—
4-axis specification	Pulse	Pulse	Pulse	Pulse					MSEP-C-4-□PI-□PI-□PI-□PI-(*)	10	—
	Pulse	Pulse	Pulse	N	Servo	N			MSEP-C-4-□PI-□PI-□PI-N-□I-N-(*)	11	—
	Pulse	Pulse	Servo	Servo					MSEP-C-4-□PI-□PI-□I-□I-(*)	12	—
	Pulse	N	Servo	Servo	Servo	N			MSEP-C-4-□PI-N-□I-□I-□I-N-(*)	13	—
	Servo	Servo	Servo	Servo					MSEP-C-4-□I-□I-□I-□I-(*)	14	—
5-axis specification	Pulse	Pulse	Pulse	Pulse	Pulse	N			MSEP-C-5-□PI-□PI-□PI-□PI-□PI-N-(*)	15	—
	Pulse	Pulse	Pulse	Pulse	Servo	N			MSEP-C-5-□PI-□PI-□PI-□PI-□I-N-(*)	16	—
	Pulse	Pulse	Pulse	N	Servo	Servo			MSEP-C-5-□PI-□PI-□PI-N-□I-□I-(*)	17	—
	Pulse	Pulse	Servo	Servo	Servo	N			MSEP-C-5-□PI-□PI-□I-□I-□I-N-(*)	18	—
	Pulse	N	Servo	Servo	Servo	Servo			MSEP-C-5-□PI-N-□I-□I-□I-□I-(*)	19	—
	Servo	Servo	Servo	Servo	Servo	N			MSEP-C-5-□I-□I-□I-□I-□I-N-(*)	20	—

Controller

PMEC
AMEC

PSEP
ASEP
DSEP

MSEP

ERC3

ERC2

PCON
-CA

PCON

ACON

SCON
-CA

MSCON

PSEL

ASEL

SSEL

XSEL

PS-24

Pulse Motor

Servo Motor (24V)

Servo Motor (200V)

Linear Servo Motor

Standard price chart

The standard price of the MSEP controller can be calculated by adding the **2** I/O type price, plus additional prices for the **3** absolute position encoder specification, and the **4** absolute data backup battery (Absolute-battery) option to the basic unit prices as listed in **1** below.

- 1** Basic unit price (Incremental specification + PIO specification) The prices of combination patterns from page 566-567 (all incremental axes).
- +
- 2** Additional price by I/O type For field network specification, please add the price.
- +
- 3** Additional price for the absolute position encoder specification For the absolute position encoder specification, please add the price for the total number of axes in the controller.
- +
- 4** Additional battery price for the absolute position encoder specification Please add the battery price for the absolute position encoder specification. If the battery is not necessary such as it is an extra module to the controller, (if configuration code ABBN for absolute position encoder specification is selected), please omit the price for **4**.

1		2	3	4	Standard price
Pattern No	Unit price (Incremental specification/ PIO specification)	Additional I/O type price	Additional absolute position encoder specification price	Additional battery price for the absolute position encoder specification	Standard price
1	—				
2	—				
3	—				
4	—				
5	—				
6	—				
7	—				
8	—				
9	—				
10	—				
11	—	DeviceNet specification	1st axis	1st axis	
12	—	—	—	—	
13	—	CC-Link specification	2nd axis	2nd axis	
14	—	—	—	—	
15	—	PROFIBUS-DP	3rd axis	3rd axis	
16	—	—	—	—	
17	—	CompoNet specification	4th axis	4th axis	
18	—	—	—	—	
19	—	MECHATROLINK specification	5th axis	5th axis	
20	—	—	—	—	
21	—	EtherCAT specification	6th axis	6th axis	
22	—	—	—	—	
23	—	EtherNet/IP specification	7th axis	7th axis	
24	—	—	—	—	
25	—	—	8th axis	8th axis	
26	—	—	—	—	
27	—				
28	—				
29	—				
30	—				
31	—				
32	—				
33	—				
34	—				
35	—				
36	—				
37	—				
38	—				
39	—				
40	—				



- Controller
- PMEC
AMEC
- PSEP
ASEP
DSEP
- MSEP
- ERC3
- ERC2
- PCON
-CA
- PCON
- ACON
- SCON
-CA
- MSCON
- PSEL
- ASEL
- SSEL
- XSEL
- PS-24
- Pulse Motor
- Servo Motor (24V)
- Servo Motor (200V)
- Linear Servo Motor

System configuration

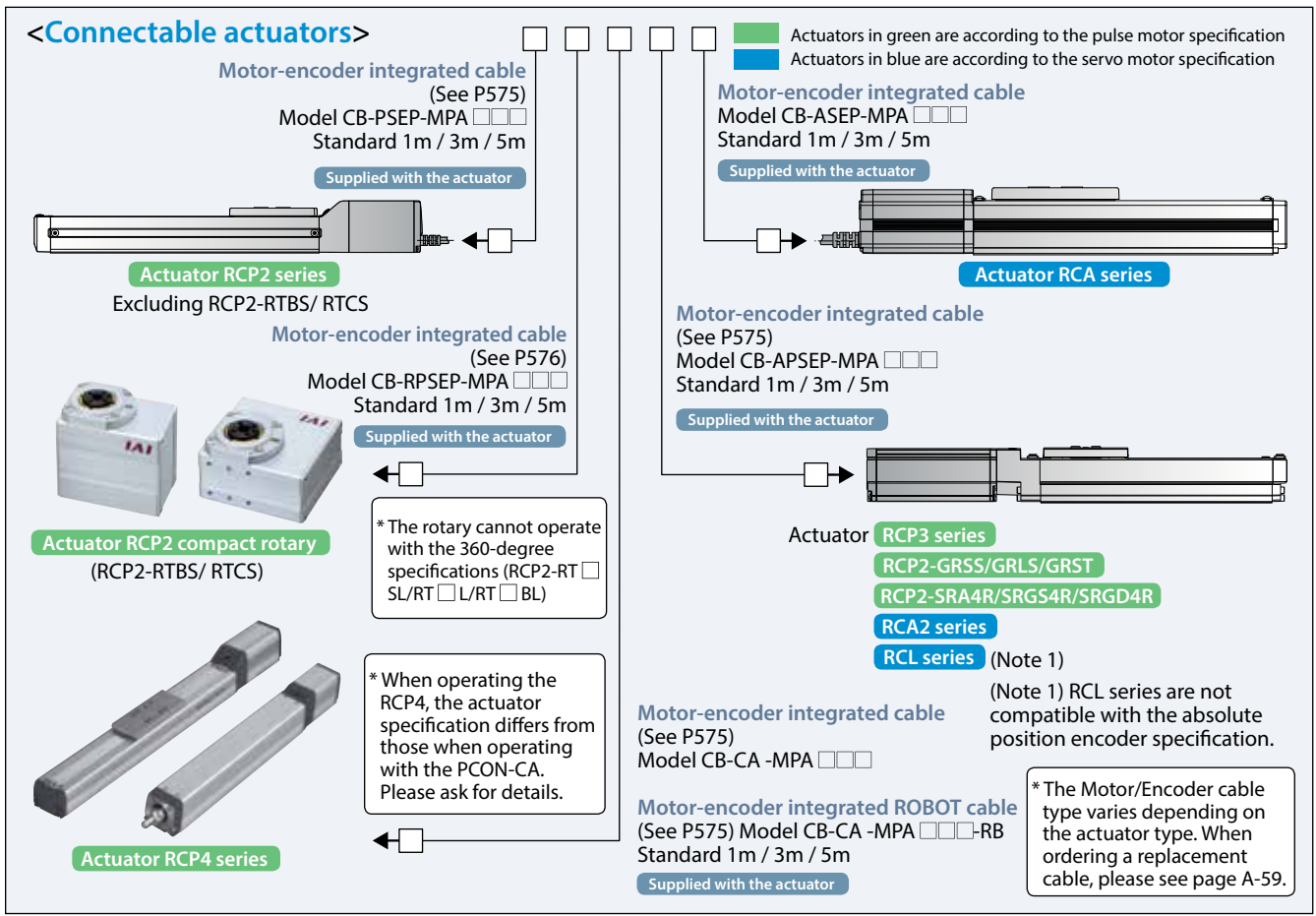
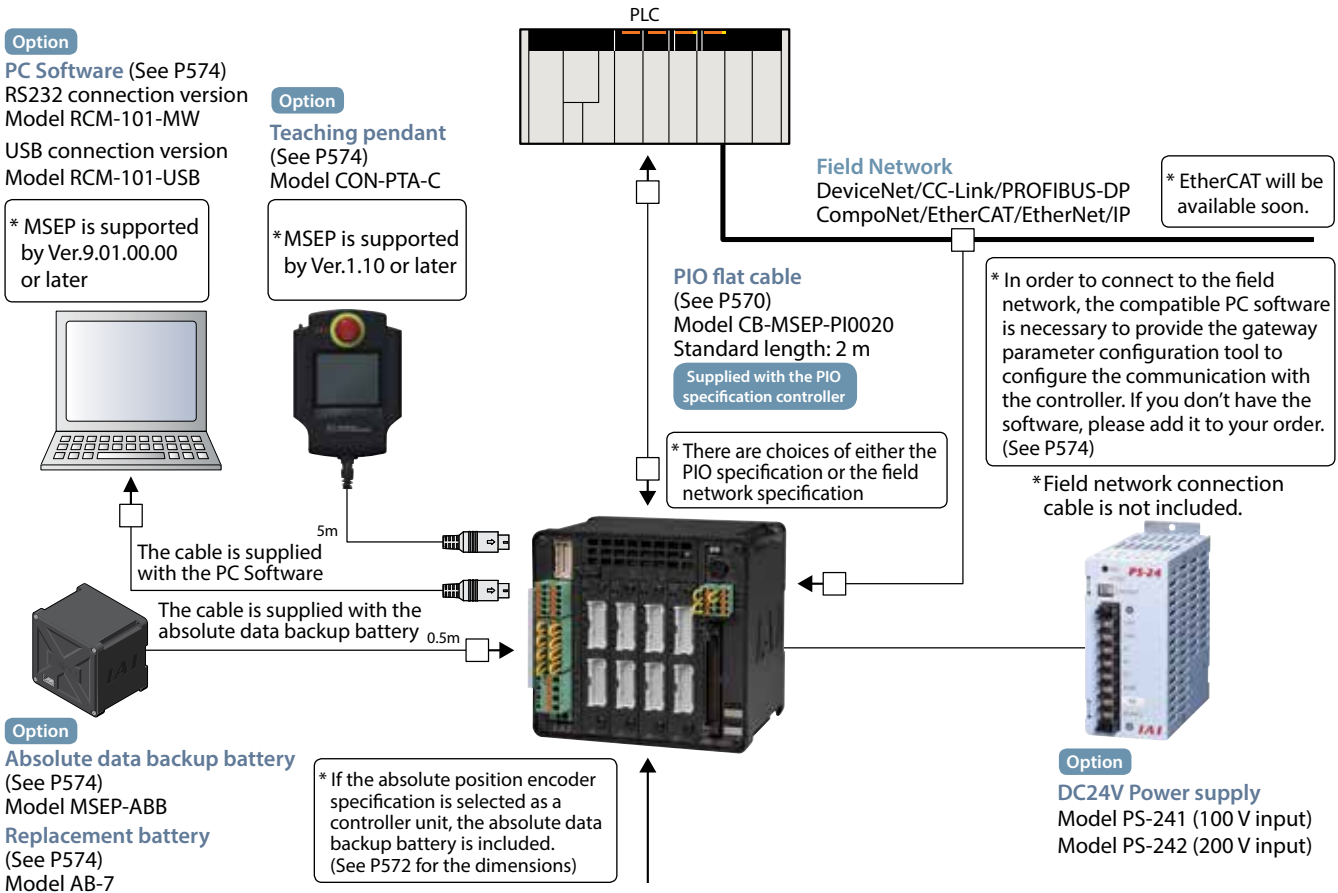

PIO Controlled Motion Mode

The MSEP controller with the PIO control specification offers the following six-motion modes. In addition, Mode No. 0 through 2 support both the single and double solenoid valves for signal configuration.

Motion Mode No.	0		1		2		3	4	5	
Motion Mode Type	Standard 2-position motion		Speed change during movement		Position data change		2-input/ 3-position motion	3-input/ 3-position motion	Continuous cycle operation	
Feature	2-position motion		2-position motion		2-position motion		3-position motion	3-position motion	2-position continuous motion	
	Push		Push		Push		Push	Push	Push	
Solenoid configurations	Single		Double		Single		—		—	
	—		Speed change during movement		Travel position data change		—		—	
Input	0	Motion signal	Motion signal 1	Motion signal	Motion signal 1	Motion signal	Motion signal 1	Retract motion signal	Continuous motion signal	
	1	Pause signal	Motion signal 2	Pause signal	Motion signal 2	Pause signal	Motion signal 2	Extend motion signal	Pause signal	
	2	Reset signal		Speed change signal (Reset signal)		Target position change signal (Reset signal)		Reset signal	Intermediate point motion command signal (Reset signal)	
	3	— /Servo-ON signal		— /Servo-ON signal		— /Servo-ON signal		— /Servo-ON signal	— /Servo-ON signal	
Output	0	Retract motion output signal		Retract motion output signal		Retract motion output signal		Retract motion output signal		Retract motion output signal
	1	Extend motion output signal		Extend motion output signal		Extend motion output signal		Extend motion output signal		Extend motion output signal
	2	Homing complete signal/ Servo-ON output signal		Homing complete signal/ Servo-ON output signal		Homing complete signal/ Servo-ON output signal		Intermediate point position output signal	Intermediate point position output signal	
	3	Alarm output signal/ Servo-ON output signal		Alarm output signal/ Servo-ON output signal		Alarm output signal/ Servo-ON output signal		Alarm output signal/ Servo-ON output signal	Alarm output signal/ Servo-ON output signal	

* Please refer to the controller operation instruction for the above signal information. (Download is available from our website)

PIO Plug Chart

Connector name: HIF6-68PA-1.27DS(Hirose Electric)					
Pin No.	Category	Signal ID	Pin No.	Category	Signal ID
A1	24V	For I/O	A18		OUT0
A2	Input (Axis No. 0)	IN0	A19	Output (Axis No. 0)	OUT1
A3		IN1	A20		OUT2
A4		IN2	A21		OUT3
A5		IN3	A22		OUT4
A6	Input (Axis No. 1)	IN4	A23	Output (Axis No. 1)	OUT5
A7		IN5	A24		OUT6
A8		IN6	A25		OUT7
A9		IN7	A26		OUT8
A10	Input (Axis No. 2)	IN8	A27	Output (Axis No. 2)	OUT9
A11		IN9	A28		OUT10
A12		IN10	A29		OUT11
A13		IN11	A30		OUT12
A14	Input (Axis No. 3)	IN12	A31	Output (Axis No. 3)	OUT13
A15		IN13	A32		OUT14
A16		IN14	A33		OUT15
A17		IN15	A34		0V

Connector name: HIF6-68PA-1.27DS(Hirose Electric)					
Pin No.	Category	Signal ID	Pin No.	Category	Signal ID
B1	24V	For I/O	B18		OUT16
B2	Input (Axis No. 4)	IN16	B19	Output (Axis No. 4)	OUT17
B3		IN17	B20		OUT18
B4		IN18	B21		OUT19
B5		IN19	B22		OUT20
B6	Input (Axis No. 5)	IN20	B23	Output (Axis No. 5)	OUT21
B7		IN21	B24		OUT22
B8		IN22	B25		OUT23
B9		IN23	B26		OUT24
B10	Input (Axis No. 6)	IN24	B27	Output (Axis No. 6)	OUT25
B11		IN25	B28		OUT26
B12		IN26	B29		OUT27
B13		IN27	B30		OUT28
B14	Input (Axis No. 7)	IN28	B31	Output (Axis No. 7)	OUT29
B15		IN29	B32		OUT30
B16		IN30	B33		OUT31
B17		IN31	B34		0V

PIO Flat Cable

Mode **CB-MSEP-PIO**

* Please indicate cable length (L) in , maximum 10m. e.g.) 020=2m

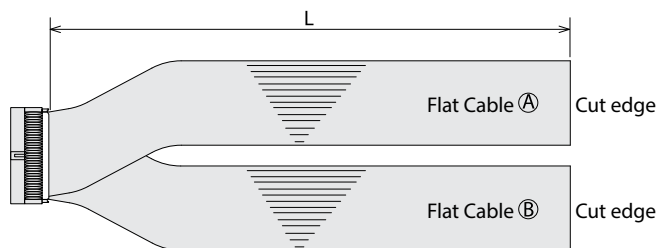

Connector: HIF6-068D-1.27R

Connection Chart

Pin No.	Signal name
A1	For I/O +24V
A2	IN0
A3	IN1
A4	IN2
A5	IN3
A6	IN4
A7	IN5
A8	IN6
A9	IN7
A10	IN8
A11	IN9
A12	IN10
A13	IN11
A14	IN12
A15	IN13
A16	IN14
A17	IN15
A18	OUT0
A19	OUT1
A20	OUT2
A21	OUT3
A22	OUT4
A23	OUT5
A24	OUT6
A25	OUT7
A26	OUT8
A27	OUT9
A28	OUT10
A29	OUT11
A30	OUT12
A31	OUT13
A32	OUT14
A33	OUT15
A34	GND for I/O

Connector: HIF6-068D-1.27R

Pin No.	Signal name
B1	For I/O +24V
B2	IN16
B3	IN17
B4	IN18
B5	IN19
B6	IN20
B7	IN21
B8	IN22
B9	IN23
B10	IN24
B11	IN25
B12	IN26
B13	IN27
B14	IN28
B15	IN29
B16	IN30
B17	IN31
B18	OUT16
B19	OUT17
B20	OUT18
B21	OUT19
B22	OUT20
B23	OUT21
B24	OUT22
B25	OUT23
B26	OUT24
B27	OUT25
B28	OUT26
B29	OUT27
B30	OUT28
B31	OUT29
B32	OUT30
B33	OUT31
B34	GND for I/O

PIO Input/Output Interface

Input External Input Specification

Item	Specification
Input voltage	DC24V ±10%
Input current	5mA, 1 circuit
ON/OFF voltage	ON voltage MIN.DC18V OFF voltage MAX.DC6V

NPN specification

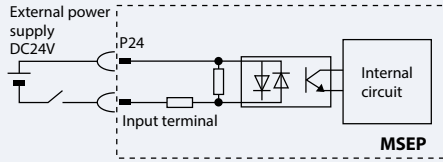

PNP specification

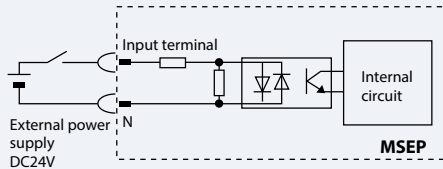

Output External Output Specification

Item	Specification
Load voltage	DC24V ±10%
Maximum load current	50mA, 1 circuit
Leakage current	MAX 2mA/one point

NPN specification

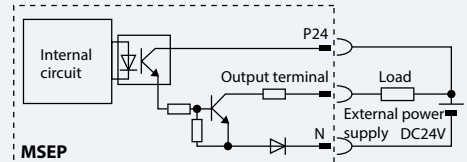

PNP specification

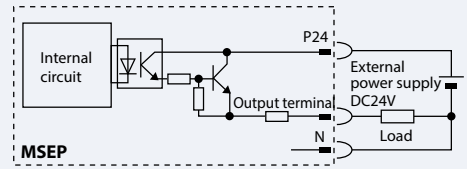

Field Network Control Motion Mode

There are five motion modes to choose from in the field network control mode with the MSEP controller as follows.

Motion pattern (*1)	Description	Outline
Positioner 1/ Simple numerical mode	Positioner 1 mode is programmable up to 256 positions of data to designate the stop position. The simple numerical control allows designating the target position numerically. They both have the capability of monitoring the current position.	
Direct numerical control mode	This mode allows designating the target position, velocity, acceleration, and current parameters for pushing. Also, it is capable of monitoring the current position, real-time velocity, and the electric current command value.	
Positioner 2 mode	Positioner 2 mode is programmable up to 256 positions of data to designate stop positions, and this mode does not allow monitoring of the current position. This mode has less in/out data transfer volume than the positioner 1 mode.	
Positioner 3 mode	Positioner 3 mode is programmable up to 256 positions of data to designate stop positions, and this mode does not allow monitoring of the current position. This mode has less in/out data transfer volume from the positioner 2 mode, and operates under minimum number of signals.	
SEP I/O	This mode allows the same functions with the field network as the PIO controlled motion mode 0 to 5 as described in the previous page.	Please refer to the PIO controlled motion mode.

(*1) Only the positioner 3 mode and the SEP I/O mode are available with CompoNet.

Table of General Specification

Specification item	Description						
Number of axes in the controller	8 axes MAX						
Controller/ Motor input power	DC24V ±10%						
Brake power supply	0.15A x Number of axis						
Controller power supply	0.8A						
Controller inrush current	5A MAX, under 30ms						
Motor consumption current	Servo motor type	Rated ampere	Maximum		Pulse motor type	Rated ampere	Maximum
			Energy saver	Standard/ Hi-accel./decel.			
	2W	0.8A	20P	1.0A	2.0A		
	5W	1.0A				4.6A	6.4A
	5W (RCA2-SA2)	1.0A	28P	2.0A	2.0A		
	10W(RCL)	1.3A				2.0A	6.4A
	10W(RCA/RCA2)		2.5A	4.4A	35P	2.0A	2.0A
	20W	1.3A	2.5A	4.4A			
	20W(20S type)	1.7A	3.4A	5.1A	42P	2.0A	2.0A
30W	1.3A	2.2A	4.4A	56P			
Motor inrush current	Slot numbers x 10A MAX, under 5ms						
Motor-encoder cable length	Maximum length 20m (note) for absolute position						
Serial communication (SIO port: dedicated teaching)	RS485 1ch (Modbus protocol compatible) Velocity 9.6~230.4kbps						
External interface	PIO specification	PIO specification : DC24 V dedicated signal in/output; Maximum input of 4 points/axis; Maximum output of 4 points/axis; Maximum cable length 10m					
	Field network specification	DeviceNet, CC-Link, PROFIBUS-DP, CompoNet, EtherCAT, EtherNet/IP(*)					
Data configuration and input method	PC software application, touch panel teaching pendant, gateway parameter configuration tool						
Data retention memory	Restore the position data and parameter in non-volatile memory (no limited input)						
Positioning points	PIO specification: 2 or 3 points Field network specification: 256 points (no limited input for the simple numerical control and the direct numerical control) (Note) The number of designated positions vary depending on the parameter configuration with motion mode selection.						
LED display (On the front panel)	LED for driver status, 8 LEDs (for each driver board) Status LED, 4 LEDs (PIO specification), 7 LEDs (Fieldbus specification)						
Electromagnetic brake force release	Enable to force-release by transmitting a deactivation signal to each axis (DC24 V input).						
Surge protection	Overcurrent protection (An interception semiconductor circuit is furnished on each slot)						
Electric shock protection	Class I basic insulation						
Insulation resistance	DC500V 10MΩ						
Weight	620g, 690g with the absolute position encoder specification plus 1950 g absolute data backup battery (8-axis specification)						
Cooling method	Forced- air cooling						
Required ambient temperature/humidity for operation	0~40°C, under 85% RH (non-condensing)						
Vibration resistance	Frequency 10~57Hz/Amplitude 0.075mm Frequency 57~150Hz/Acceleration 9.8m/s ² Each XYZ direction, sweep time 10 minutes, sweep count 10 times						
Shock resistance	150mm/s ² , 11 ms half sine wave pulse, each XYZ direction 3 times						
International Protection code	IP20						

(*) EtherCAT will be available soon.

Exterior Dimensions

Controller

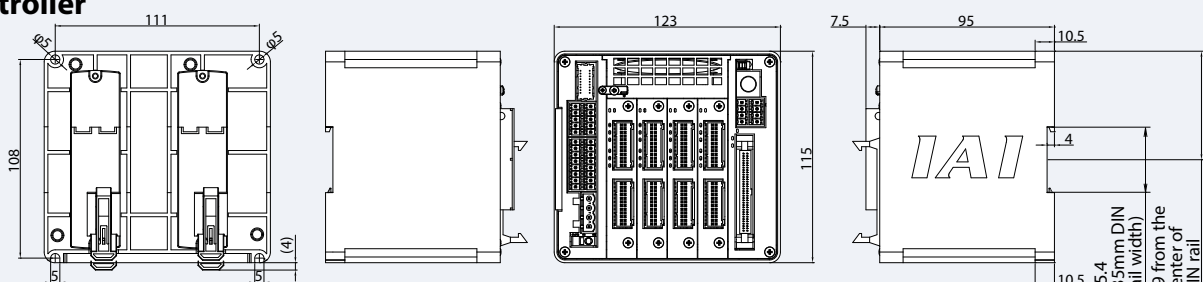

Absolute data backup battery box

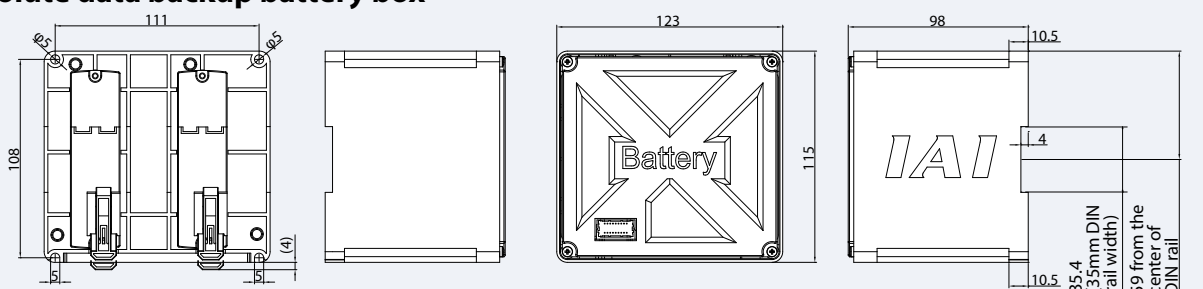

Names of the MSEP Controller components

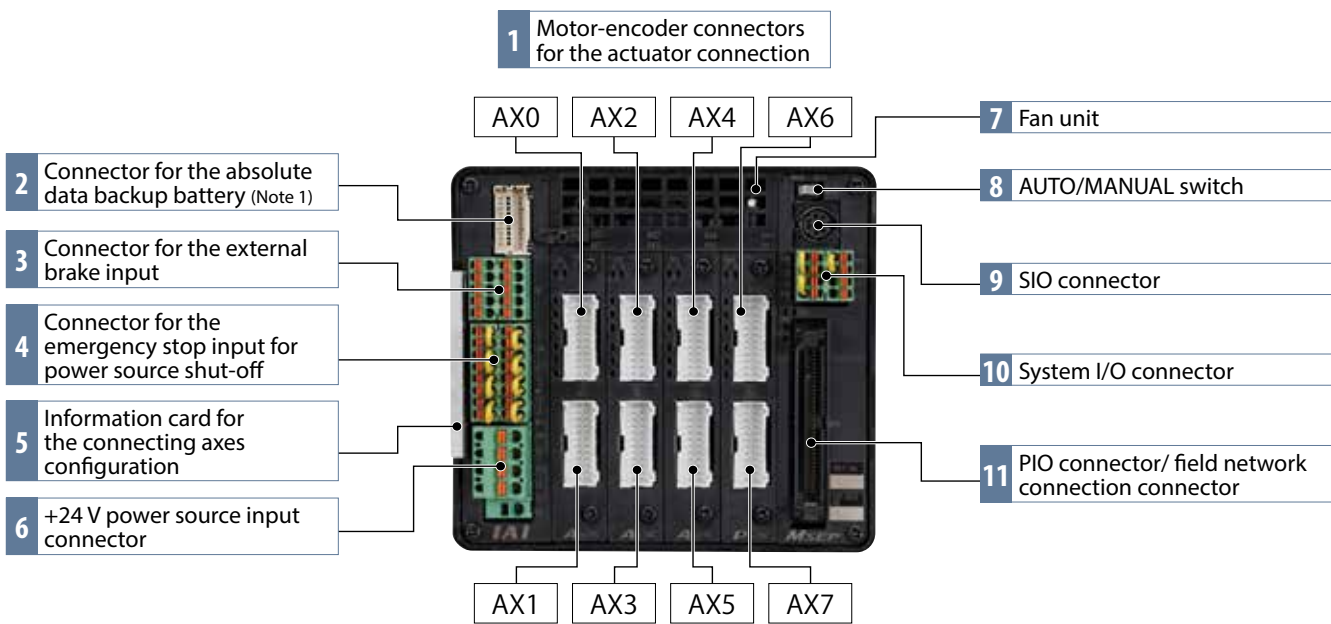

Note) All the connectors are represented as AX0 through AX7. Please be aware that the motor-encoder cable for the first axis is to be connected to AX0 and the second axis to AX1 respectively.

Descriptions of the components

- 1 Motor-encoder connectors for the actuator connection**
Connect motor-encoder cable to the actuator.
- 2 Connector for the absolute data backup battery** (Note 1) Connector is not used for the incremental specification.
Connect the absolute data backup battery if the controller has the absolute position encoder specification.
- 3 Connector for the external brake input**
The connector to input a signal to release the brake for the actuator externally.
- 4 Connector for the emergency stop input for power source shut-off**
The emergency stop input connector to connect in/output terminal of the external relay of the motor drive shut-off and each driver slot (*1).
- 5 Information card for configuration of the connecting axes**
The information card contains information regarding the configuration of the controller axes which is removable to examine the contents.
- 6 +24 V power source input connector**
The main power source connector for the controller: Motor drive source shut-down is possible while restoring the power source for the controller unit in case of an emergency shut-down; This is because the terminals for the power source of the motor and the controller are separate.
- 7 Fan unit**
Easily replaceable fan unit. (Replacement fan unit: Model MSEP-FU).
- 8 AUTO/MANUAL switch**
To switch automatic operation to/from manual operation.
- 9 SIO connector**
To connect teaching box and the connecting cable for PC software.
- 10 System I/O connector**
The connector for remote AUTO/MANU switch input and emergency stop input for the entire controller with functions including an external regeneration-resistance expansion terminal.
- 11 PIO connector/ field network connection connector**
The PIO specification — connects to a 68-pin ribbon I/O cable.
The field network specification — connects to a field network type specified on the MSEP controller.

(*1) The shut-off feature is available on a single slot basis which is for two axes per slot. Please note that a single axis basis cannot be accommodated.

Options

Teaching pendant

Summary Teaching device for positioning input, test operation, and monitoring.

Model **CON-PTA-C** (Touch panel teaching pendant)

Setting

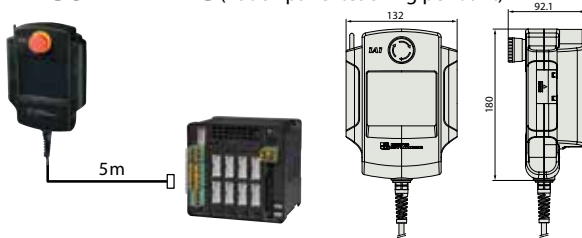

Specification

Item	CON-PTA-C-ENG
Data input	○
Actuator motion	○
Operating ambient temperature/humidity	Temperature 0 to 40°C, humidity 85%RH or less
Operating environment	Free from corrosive gas and especially, considerably dusty condition
Protection degree	IP40
Weight	Approximately 570g
Cable length	5m
Display	65,536 color White LED back light
Standard price	—

PC software (Windows only) * For the field network specification, the PC software is required.

Summary A startup support software for inputting positions, performing test runs, and monitoring. With enhancements for adjustment functions, the startup time is shortened.

Model **RCM-101-MW** (External device communication cable + RS232 conversion unit)

Setting

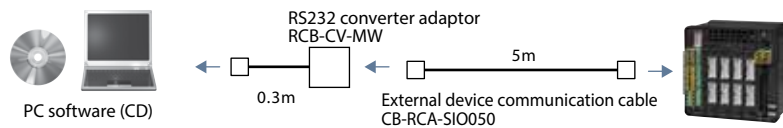

Supported Windows OS: 2000 SP4 or later / XP SP2 or later / Vista / 7



Model **RCM-101-USB** (External device communication cable + USB converter adaptor + USB cable)

Setting

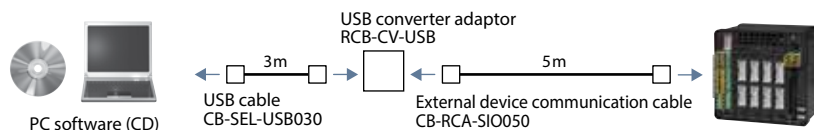

External regeneration resistor

Summary The regeneration resistor converts regenerated current dissipated during deceleration of the motor load into heat. The MSEP controller has an internal regeneration resistor for ordinary operations, however, depending on the operational condition, please install an external regeneration resistor if the internal regeneration resistor capacity is insufficient.

Note: When 3 or more servo actuators with the HA option are used then a regeneration resistor is recommended to convert the excess motor current into heat.

Model **RER-1**

Exterior dimensions

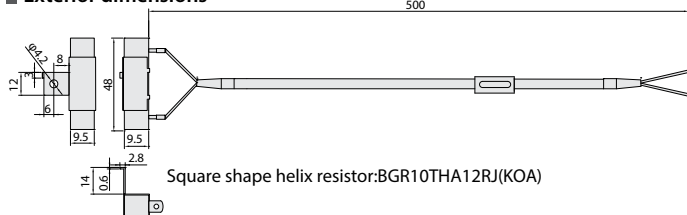

Driver board

Summary A supplement or modification to the driver board is feasible with the MSEP controller. When the actuator that control motions needs to be modified, just replacing the driver board would serve the purpose without changing the entire controller. (The parameters need to be adjusted when changing the driver board)

Model

	Type		Model	Standard price
For the pulse motor	Incremental	1-axis	MSEP-PD1-I	—
		2-axis	MSEP-PD2-I	—
	Absolute position encoder	1-axis	MSEP-PD1-A	—
		2-axis	MSEP-PD2-A	—
For the servo motor	Incremental	1-axis	MSEP-AD1-I	—
		2-axis	MSEP-AD2-I	—
	Absolute position encoder	1-axis	MSEP-AD1-A	—
		2-axis	MSEP-AD2-A	—

Box for the absolute data backup battery

Summary If the absolute position encoder specification is selected with code ABB, the absolute data backup battery box is included with the controller. However, if the battery box is ordered as a separate unit, it does not include the battery but just the box itself. If the battery is needed, please purchase it separately. (Model: AB-7).

Model **MSEP-ABB** (Battery not included)

Exterior dimensions See P. 572

* A cable (Model CB-MSEP-AB005) that connects the absolute data backup battery box to the MSEP is included with the box.

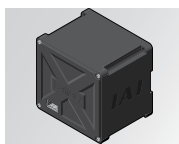

Replacement battery

Summary The replacement battery for the absolute data backup battery box.

Model **AB-7**



Replacement fan unit

Model **MSEP-FU**

Service Parts

Integrated Motor-Encoder Cable/ Motor-Encoder Robot Cable for RCP4

Model **CB-CA-MPA** / **CB-CA-MPA** -**RB**

*Enter the cable length (L) into . Compatible to a maximum of 20 meters.
Ex.: 080 = 8m

*Refer to page A-59 for connectable actuators.

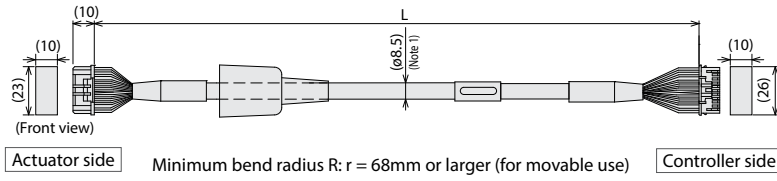

Minimum bend radius R: r = 68mm or larger (for movable use)

*The robot cable is designed for flex-resistance:
Please use the robot cable if the cable has to be installed through the cable track.

(Note 1) If cable length is 5m or more, non-robotic cable is $\phi 9.1$ and robot cable is $\phi 10$.

Actuator side 1-1827863-1 (AMP)			Controller side PADP-24V-1-S (JST)		
Pin No.	Signal name	Color	Pin No.	Signal name	Color
A1	\emptyset A/U	Blue(Black)	1	\emptyset A/U	Blue (Black)
B1	VMM/V	Orange (White)	2	VMM/V	Orange (White)
A2	\emptyset A/W	Green (Brown)	5	\emptyset A/W	Green (Brown)
B2	\emptyset B/-	Brown (Green)	3	\emptyset B/-	Brown (Green)
A3	VMM/-	Gray (Yellow)	4	VMM/-	Gray (Yellow)
B3	\emptyset B/+	Red (Red)	6	\emptyset B/+	Red (Red)
A4	LS+/BK+	Black (Orange)	7	LS+/BK+	Black (Orange)
B4	LS-/BK-	Yellow (Gray)	8	LS-/BK-	Yellow (Gray)
A6	-/A+	Blue (White)	11	-/A+	Blue (White)
B6	-/A-	Orange (Yellow)	12	-/A-	Orange (Yellow)
A7	A+/B+	Green (Red)	13	A+/B+	Green (Red)
B7	A-/B-	Brown (Green)	14	A-/B-	Brown (Green)
A8	B+/Z+	Gray (Black)	15	B+/Z+	Gray (Black)
B8	B-/Z-	Red (Brown)	16	B-/Z-	Red (Brown)
A5	BK+/LS+	Blue (Black)	9	BK+/LS+	Blue (Black)
B5	BK-/LS-	Orange (Brown)	10	BK-/LS-	Orange (Brown)
A9	LS_GND	Green (Green)	20	LS_GND	Green (Green)
B9	VPS	Brown (Red)	18	VPS	Brown (Red)
A10	VCC	Gray (White)	17	VCC	Gray (White)
B10	GND	Red (Yellow)	19	GND	Red (Yellow)
A11	—	—	21	—	—
B11	FG	Black (—)	22	—	—
			23	—	—
			24	FG	Black (—)

* Color in () indicates color of robot cable

Integrated Motor-Encoder Robot Cable/ Motor-Encoder Cable for RCP3/RCA2 and others

Model **CB-APSEP-MPA** / **CB-APSEP-MPA** -**LC**

*Enter the cable length (L) into . Compatible to a maximum of 20 meters.
Ex.: 080 = 8m

*Refer to page A-59 for connectable actuators.

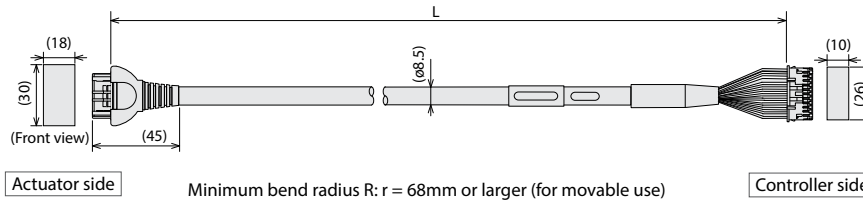

Minimum bend radius R: r = 68mm or larger (for movable use)

Actuator side Pin number	[PCON](ACON)	Controller side Pin number
A1	Black [\emptyset A](U)	1
B1	White [VMM](V)	2
A2	Brown [\emptyset A](W)	5
B2	Green [\emptyset B](-)	3
A3	Yellow [VMM](-)	4
B3	Red [\emptyset B](+)	6
A4	Orange [LS+](BK+)	7
B4	Gray [LS-](BK-)	8
A6	White [-](A+)	11
B6	Yellow [-](A-)	12
A7	Red [A+](B+)	13
B7	Green [A-](B-)	14
A8	Black [B+](Z+)	15
B8	Brown [B-](Z-)	16
A5	Black (label)[BK+](LS+)	9
B5	Brown (label)[BK-](LS-)	10
A9	Green (label)GNDs	20
B9	Red (label)VPS	18
A10	White (label)VCC	17
B10	Yellow (label)GND	19
A11	NC	21
B11	Shield (FG)(FG)	24
	NC	22
	NC	23

Integrated Motor-Encoder Robot Cable for RCP2

Model **CB-PSEP-MPA**

* Robot cable is the standard specification.

*Enter the cable length (L) into . Compatible to a maximum of 20 meters.
Ex.: 080 = 8m

*Refer to page A-59 for connectable actuators.

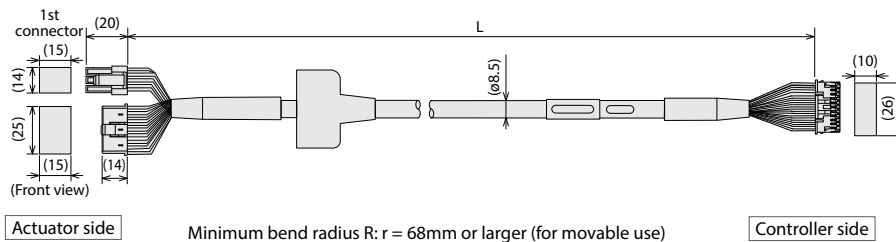

Minimum bend radius R: r = 68mm or larger (for movable use)

Actuator side Pin number	Controller side Pin number
1	Black [\emptyset A]
2	White [VMM]
4	Red [\emptyset B]
5	Green [VMM]
6	Brown [\emptyset A]
6	Yellow [\emptyset B]
16	Orange [BK+]
17	Gray [BK-]
5	NC
6	NC
13	Black [LS+]
14	Brown [LS-]
1	White [A+]
2	Yellow [A-]
3	Red [B+]
4	Green [B-]
10	White (label)[VCC]
11	Yellow (label)[VPS]
9	Red (label)[GND]
12	Green (label)[Spare]
15	NC
7	NC
8	NC
18	Shield [FG]

Integrated Motor-Encoder Robot Cable for RCP2-RTBS/RTBSL/RTCS/RTCSL

Model **CB-RPSEP-MPA**

* Robot cable is the standard specification.

*Enter the cable length (L) into . Compatible to a maximum of 20 meters.
Ex: 080 = 8m

*Refer to page A-59 for connectable actuators.

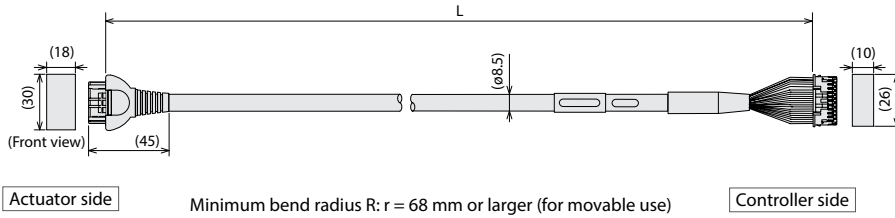

Actuator side Pin number		Controller side Pin number
A1	Black (ØA)	1
B1	White (VMM)	2
A2	Brown (Ø/A)	5
B2	Green (ØB)	3
A3	Yellow (VMM)	4
B3	Red (Ø/B)	6
A6	Orange (LS+)	7
B6	Gray (LS-)	8
A7	Red (A+)	13
B7	Green (A-)	14
A8	Black (B+)	15
B8	Brown (B-)	16
A4	NC	-
B4	NC	-
A5	Black (label)(BK-)	9
B5	Brown (label)(BK-)	10
A9	Green (label)(GNDLS)	20
B9	Red (label)(VPS)	18
A10	White (label)(VCC)	17
B10	Yellow (label)(GND)	19
A11	Shield (FG)	21
B11	NC	22
	NC	23

Integrated Motor-Encoder Robot Cable for RCA

Model **CB-ASEP-MPA**

* Robot cable is the standard specification.

*Enter the cable length (L) into . Compatible to a maximum of 20 meters.
Ex: 080 = 8m

*Refer to page A-59 for connectable actuators.

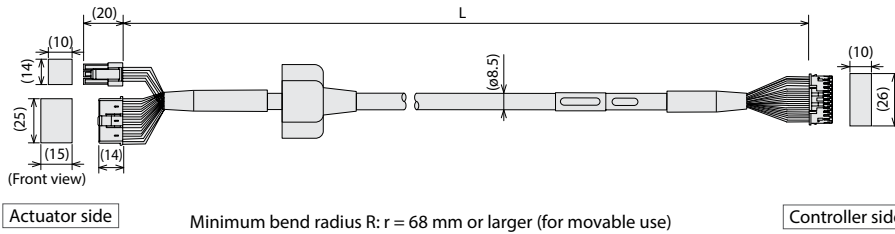

Actuator side Pin number		Controller side Pin number
1	Red (U)	1
2	Yellow (V)	2
-	NC	3
-	NC	4
3	Black (W)	5
-	NC	6
-	Orange (BK+)	7
18	Gray (BK-)	8
17	Black (LS+)	9
7	Brown (LS-)	10
16	White (A+)	11
1	Yellow (A-)	12
2	Red (B+)	13
3	Green (B-)	14
4	Black (label)(Z+)	15
10	Brown (label)(Z-)	16
11	White (label)(VCC)	17
14	Yellow (label)(VPS)	18
13	Red (label)(GND)	19
15	Green (label)(Spare)	20
6	NC	21
5	NC	22
8	NC	23
12	NC	24
9	Shield (FG)	

- Controller
- PMEC
AMEC
- PSEP
ASEP
DSEP
- MSEP
- ERC3
- ERC2
- PCON
-CA
- PCON
- ACON
- SCON
-CA
- MSCON
- PSEL
- ASEL
- SSEL
- XSEL
- PS-24

ERC3 controller specification



■ Model number NP/PN/SE/PLN/PLP
Controller part of actuator with built-in controller

List of Models

Controller type	CON type					MEC type		
Operation mode	Positioner mode			Pulse-train control mode		Positioner mode		
I/O type	PIO		SIO	NPN	PNP	PIO		SIO
	NPN	PNP				NPN	PNP	
Type (I/O type)	NP	PN	SE	PLN	PLP	NP	PN	SE
Position points	16 points		512 points (When the PIO converter or gateway unit is used)	—	—	3 points		2 points/ 3 points
Description	Basic type	Basic type	The PIO converter or gateway unit can be used. (Note)	When pulse trains are used	When pulse trains are used	3-point movement	3-point movement	The Quick Teach and PIO converter or gateway unit can be used. (Note)
External view								
Standard price	—							

(Note) The PIO converter and gateway unit cannot be used at the same time.

Model number

⑦ & ⑨ refers to the I/O type and controller type shown in the above table.

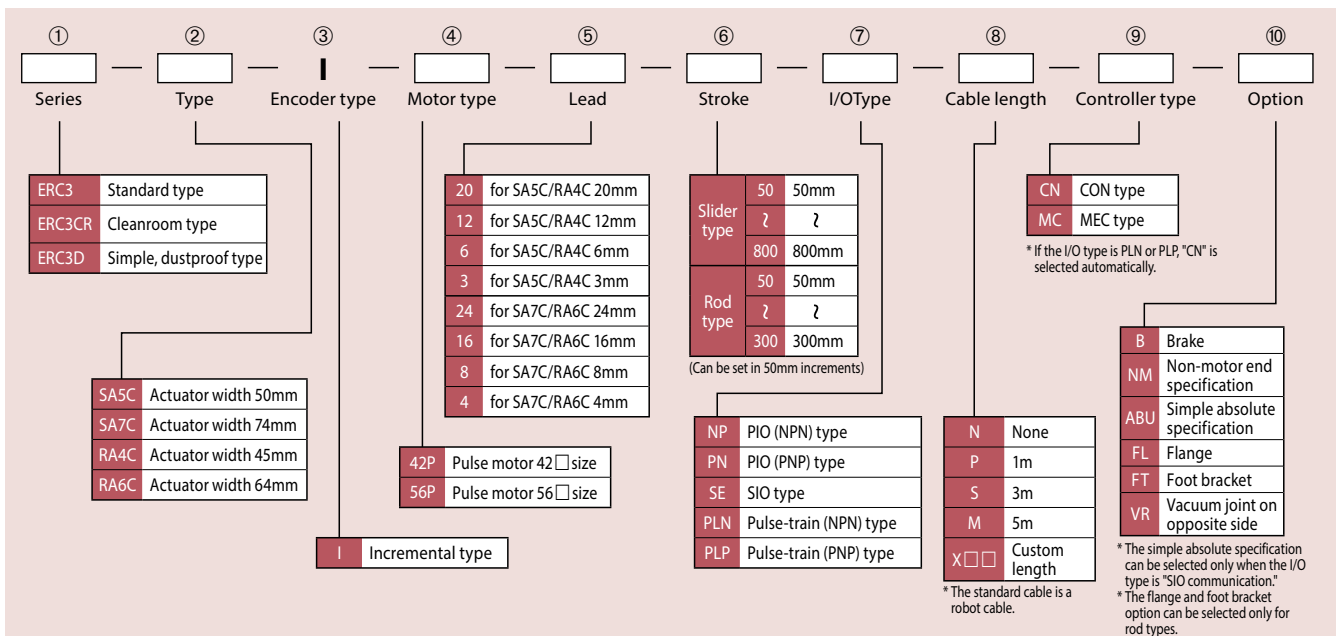

577 ERC3

System Configuration

PIO Type/Pulse-train type

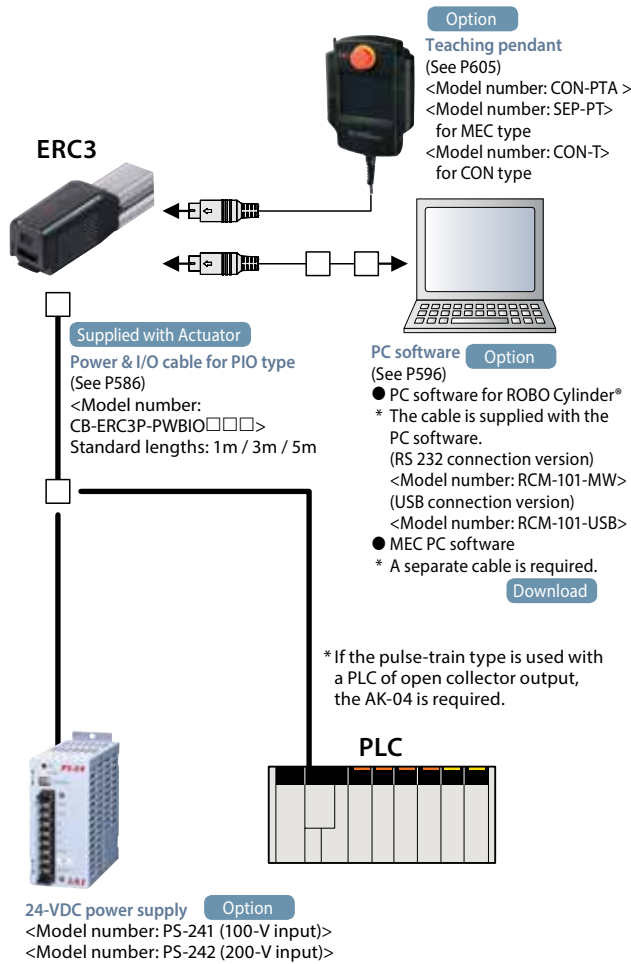

SIO Type

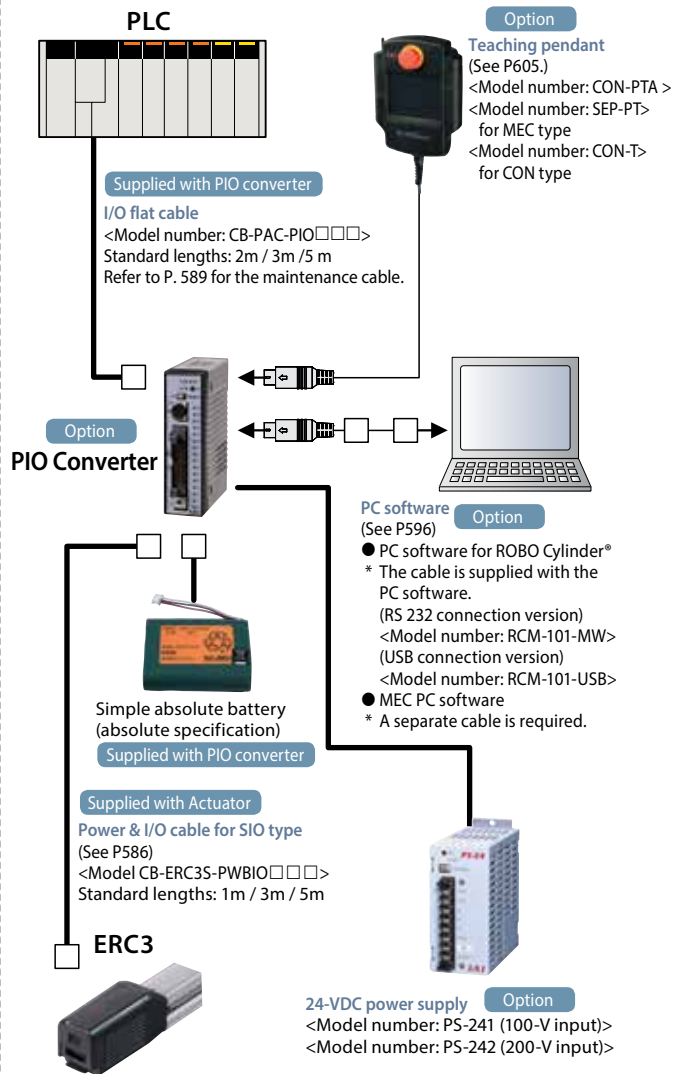

PC Wiring Diagram

The SIO connector is used to connect a teaching tool.

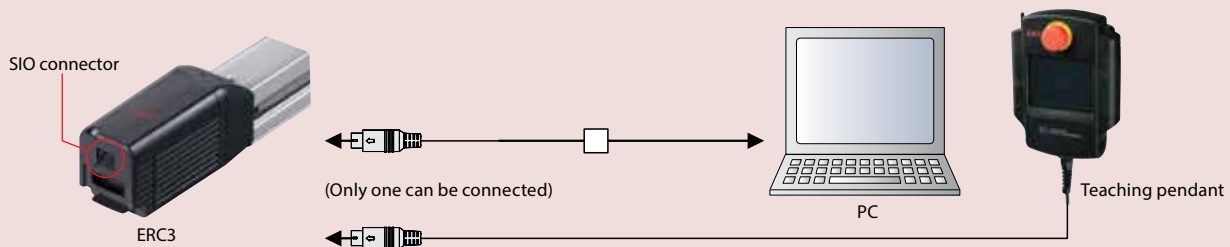

- Controller
- PMEC
AMEC
- PSEP
ASEP
DSEP
- MSEP
- ERC3**
- ERC2
- PCON
-CA
- PCON
- ACON
- SCON
-CA
- MSCON
- PSEL
- ASEL
- SSEL
- XSEL
- PS-24
- Pulse Motor
- Servo Motor (24V)
- Servo Motor (200V)
- Linear Servo Motor

List of Base Controller Specifications

Item	Description	
Power supply voltage	24 VDC±10%	
Load current (including current consumed for control)	High-output setting enabled: 3.5 A rated/4.2 A max. High-output setting disabled: 2.2A	
Heat output	High-output setting enabled: 8 W High-output setting disabled: 5W	
Rush current (Note 1)	8.3A	
Momentary power failure resistance	MAX. 500µs	
Motor control method	Field-weakening vector control	
Supported encoder	Incremental encoder of 800 pulses/rev in resolution	
Actuator cable length	10 m max.	
Serial communication interface (SIO port)	RS485: 1 channel (conforming to Modbus protocol RTU/ASCII) / Speed: 9.6 to 230.4 kbps Actuators can be controlled via serial communication in a mode other than pulse-train	
External interface PIO specification	Dedicated 24-VDC signal input/output (NPN or PNP selected)—Up to 6 input points, up to 4 output points Cable length: 10m max.	
Data setting/input method	PC software, touch-panel teaching pendant, quick teach	
Data retention memory	Position data and parameters are saved in the non-volatile memory (There is no limit to the number of times the memory can be written.)	
Operation mode	Positioner mode/Pulse-train control mode	
Number of positions in positioner mode	Standard 8 points, maximum 16 points Note) Positioning points vary depending on the selected PIO pattern.	
Pulse-train interface	Input pulse	Differential method (line driver method): 200 kpps max. / Cable length: 10m max. Open collector method: Not supported * If the host is of open collector output type, use the optional AK-04 (sold separately) to convert open collector pulses to differential pulses.
	Command pulse magnification (electronic gear ratio: A/B)	1/50 < A/B < 50/1 Setting range of A and B (set by parameters): 1 to 4096
	Feedback pulse output	None
LED indicators (installed on the motor unit)	Servo ON (green), servo OFF (unlit), emergency stop (red), alarm (red), resetting (orange)	
Isolation resistance	500 VDC, 10 MΩ or more	
Electric shock protection mechanism	Class I basic isolation	
Cooling method	Natural air cooling	
Environment	Ambient operating temperature	0 to 40°C
	Ambient operating humidity	85%RH or less (non-condensing)
	Ambient storage temperature	-20 to 70°C (excluding batteries)
	Operating altitude	Altitude 1000m or less
	Protection degree	IP20
	Cooling method	Natural air cooling
	Vibration resistance	Number of vibrations: 10 to 57 Hz/Amplitude: 0.075 mm (Test conditions) Number of vibrations: 57 to 150 Hz/Acceleration: 9.8 m/s ² Sweep time in X/Y/Z directions: 10 minutes/Number of sweeps: 10 times
Impact	(Test conditions) 150mm/sec ² , 11mm/sec, sinusoidal half pulse, 3 times each in X, Y and Z directions	

Note 1 Rush current will flow for approx. 5msec after the power is turned on (at 40°C).
Take note that the value of rush current varies depending on the impedance of the power line.

Emergency Stop Circuit

The ERC3 series has no built-in emergency stop circuit, so the customer must provide an emergency stop circuit. Refer to the operation manual for details on the emergency stop circuit.

Positioner mode

I/O specification (PIO type)

Input Part

Item	Specification
Input points	6 points
Input voltage	24 VDC ±10%
Input current	5mA/1 circuit
Leak current	1mA/point max.

* The input circuit is not isolated from signals input from external equipment.

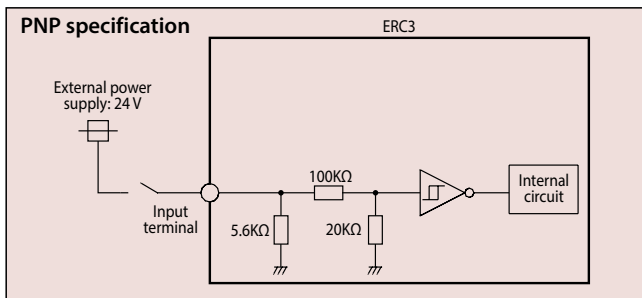
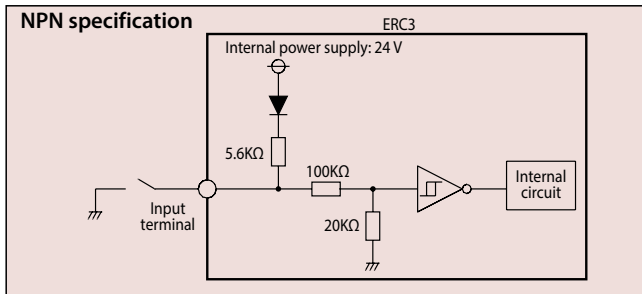

Output Part

Item	Specification
Output points	4 points
Load voltage	24 VDC ±10%
Maximum load current	5mA/1 circuit
Residual voltage	2 V or less

* The output circuit is not isolated from signals output to external equipment.

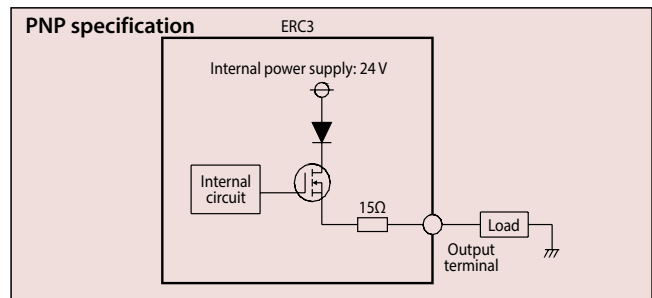
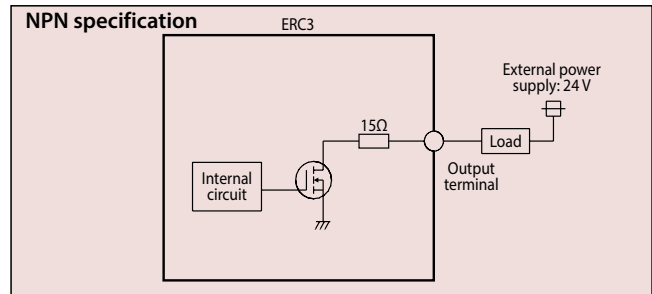

I/O Signal Table (PIO Type) [ERC3 and PLC Connected Directly]

Pin number	Category	Controller type PIO function	CN (CON type) Parameter No. 25 (PIO pattern) selection			MC (MEC type) Selected on teaching pendant or in PC software	
			0	1	2	Standard/Movement between 2 points (single solenoid) / 2 inputs/Movement among 3 points	
			8-point type	Solenoid type	16-point type		
		Number of positioning points	8 points	3 points	16 points	2 points	3 points
	Input	Home return signal	○	×	×	×	×
		Jog signal	×	×	×	×	×
		Teaching signal (writing of current position)	×	×	×	×	×
		Brake release	×	×	×	×	×
	Output	Moving signal	×	×	×	×	×
		Zone signal	○	×	○	×	×
		Position zone signal	×	×	○	×	×
A1	Frame ground				FG		
B1	+24V for control power supply				CP		
A2	-						
B2	0V for control power supply				GND		
A3	External brake release input				BK		
B3	+24V for motor power supply				MP		
A4	Emergency stop input				EMG		
B4	0V for motor power supply				GND		
A5	-						
B5	-						
A6	-						
B6	-						
A7	-						
B7	-						
A8	-						
B8	-						
A9	Input	IN0	PC1	ST0	PC1	ST0	ST0
B9		IN1	PC2	ST1	PC2	—	ST1
A10		IN2	PC4	ST2	PC4	RES	RES
B10		IN3	HOME	—	PC8	—	—
A11		IN4	CSTR	RES	CSTR	—	—
B11	IN5	*STP	*STP	*STP	—	—	
A12	Output	OUT0	PEND	PE0	PEND	LS0/PE0	LS0/PE0
B12		OUT1	HEND	PE1	HEND	LS1/PE1	LS1/PE1
A13		OUT2	ZONE1	PE2	PZONE/ZONE1	HEND	LS2/PE2
B13		OUT3	*ALM	*ALM	*ALM	*ALM	*ALM

(Note) Signals marked with an asterisk (*) (ALM/STP) are negative logic signals so they are normally on.

- Controller
- PMEC
AMEC
- PSEP
ASEP
DSEP
- MSEP
- ERC3**
- ERC2
- PCON
-CA
- PCON
- ACON
- SCON
-CA
- MSCON
- PSEL
- ASEL
- SSEL
- XSEL
- PS-24
- Pulse Motor
- Servo Motor (24V)
- Servo Motor (200V)
- Linear Servo Motor

I/O Signal Table (SIO Type) [ERC3 and PLC Connected via PIO Converter]

Pin number	Category	Controller type PIO function	CN (CON type)						MC (MEC type)	
			Parameter No. 25 (PIO pattern) selection						Selected on teaching pendant or in PC software	
			0	1	2	3	4	5	Standard/Movement between 2 points (single solenoid)	2 inputs/Movement among 3 points
			Positioning mode	Teaching mode	256-point mode	512-point mode	Solenoid valve mode 1	Solenoid valve mode 2		
	Input	Number of positioning points	64 points	64 points	256 points	512 points	7 points	3 points	2 points	3 points
	Input	Home return signal	○	○	○	○	○	×	×	×
	Input	Jog signal	×	○	×	×	×	×	×	×
	Input	Teaching signal (writing of current position)	×	○	×	×	×	×	×	×
	Input	Brake release	○	×	○	○	○	○	×	×
	Output	Moving signal	○	○	×	×	×	×	×	×
	Output	Zone signal	○	×	×	×	○	○	×	×
	Output	Position zone signal	○	○	○	×	○	○	×	×
1A	—									
2A	—									
3A	—									
4A	—									
5A	PIO converter	IN0	PC1	PC1	PC1	PC1	ST0	ST0	ST0	ST0
6A		IN1	PC2	PC2	PC2	PC2	ST1	ST1(JOG+)	—	ST1
7A		IN2	PC4	PC4	PC4	PC4	ST2	ST2 *1	RES	RES
8A		IN3	PC8	PC8	PC8	PC8	ST3	—	—	—
9A		IN4	PC16	PC16	PC16	PC16	ST4	—	—	—
10A		IN5	PC32	PC32	PC32	PC32	ST5	—	—	—
11A		IN6	—	MODE	PC64	PC64	ST6	—	—	—
12A		IN7	—	JISL	PC128	PC128	—	—	—	—
13A		IN8	—	JOG+	—	PC256	—	—	—	—
14A		IN9	BKRL	JOG-	BKRL	BKRL	BKRL	BKRL	—	—
15A		IN10	—	—	—	—	—	—	—	—
16A		IN11	HOME	HOME	HOME	HOME	HOME	—	—	—
17A		IN12	*STP	*STP	*STP	*STP	*STP	—	—	—
18A		IN13	CSTR	CSTR/PWRT	CSTR	CSTR	—	—	—	—
19A		IN14	RES	RES	RES	RES	RES	RES	—	—
20A	IN15	SON	SON	SON	SON	SON	SON	—	—	
1B	PIO converter	OUT0	PM1(ALM1)	PM1(ALM1)	PM1(ALM1)	PM1(ALM1)	PE0	LSO	LSO/PE0	LSO/PE0
2B		OUT1	PM2(ALM2)	PM2(ALM2)	PM2(ALM2)	PM2(ALM2)	PE1	LS1(TRQS)	LS1/PE1	LS1/PE1
3B		OUT2	PM4(ALM4)	PM4(ALM4)	PM4(ALM4)	PM4(ALM4)	PE2	LS2 *1	HEND	LS2/PE2
4B		OUT3	PM8(ALM8)	PM8(ALM8)	PM8(ALM8)	PM8(ALM8)	PE3	—	*ALM	*ALM
5B		OUT4	PM16	PM16	PM16	PM16	PE4	—	—	—
6B		OUT5	PM32	PM32	PM32	PM32	PE5	—	—	—
7B		OUT6	MOVE	MOVE	PM64	PM64	PE6	—	—	—
8B		OUT7	ZONE1	MODES	PM128	PM128	ZONE1	ZONE1	—	—
9B		OUT8	PZONE/ZONE2	PZONE/ZONE1	PZONE/ZONE1	PM256	PZONE/ZONE2	PZONE/ZONE2	—	—
10B		OUT9	—	—	—	—	—	—	—	—
11B		OUT10	HEND	HEND	HEND	HEND	HEND	HEND	—	—
12B		OUT11	PEND	PEND/WEND	PEND	PEND	PEND	—	—	—
13B		OUT12	SV	SV	SV	SV	SV	SV	—	—
14B		OUT13	*EMGS	*EMGS	*EMGS	*EMGS	*EMGS	*EMGS	—	—
15B		OUT14	*ALM	*LM	*ALM	*ALM	*ALM	*ALM	—	—
16B	OUT15	LOAD/TRQS *ALML	*ALML	LOAD/TRQS *ALML	LOAD/TRQS *ALML	LOAD/TRQS *ALML	LOAD/TRQS *ALML	—	—	
17B	—									
18B	—									
19B	—									
20B	—									

(Note) In the table above, codes in () indicate functions effective before the home return. * indicates a negative logic signal.
 PM1 to PM8 serve as alarm binary code output signals when an alarm occurs.
 *1 These signals are invalid before the home return.

Explanation of Signal Names

Category	Signal name	Signal abbreviation	Function overview
Input	PTP strobe (start signal)	CSTR	The actuator starts moving to the position set by the command position number.
	Command position number	PC1~PC256	This signal is used to input the position number of the position to move the actuator to (binary input).
	Forced brake release	BKRL	The brake is forcibly released.
	Pause	*STP	When this signal turns OFF while the actuator is moving, the actuator will decelerate to a stop. The remaining travel is put on hold while the actuator is stopped and will resume when the signal turns ON.
	Reset	RES	Present alarms are reset when this signal turns ON. By turning ON this signal while the actuator is paused (*STP signal is OFF), the remaining travel can be cancelled.
	Servo ON	SON	The servo is ON while this signal is ON, and OFF while the signal is OFF.
	Home return	HOME	Home return operation is performed when this signal is turned ON.
	Teaching mode	MODE	The actuator switches to the teaching mode when this signal turns ON. The mode will not change unless the CSTR, JOG+ and JOG- signals are all OFF and the actuator is not operating.
	Jog/inching switching	JISL	The actuator can be jogged with a JOG+ or JOG- command while this signal is OFF. The actuator operates by inching with a JOG+ or JOG- command while this signal is ON.
	Jog	JOG + JOG -	When the JISL signal is OFF, the actuator jogs in the positive direction upon detection of the ON edge of the JOG+ signal, or in the negative direction upon detection of the ON edge of the JOG- signal. The actuator decelerates to a stop if the OFF edge is detected while jogging in each direction. The actuator operates by inching when the JISL signal is ON.
	Current position write	PWRT	When a position number is specified and this signal is turned ON for 20 ms or more in the teaching mode, the current position is written to the specified position number.
	Output	Start signal	ST0~ST6
Positioning complete		PEND/INP	This signal turns ON when the actuator reaches the positioning band after moving. The PEND signal does not turn OFF even when the actuator moves beyond the positioning band, but the INP signal turns OFF. A parameter is used to switch between PEND and INP.
Completed position number		PM1~PM256	The position number of the position reached upon completion of positioning is output (by a binary signal).
Home return complete		HEND	This signal turns ON upon completion of home return. It will remain ON until the home position is lost.
Zone signal 1		ZONE1	This signal turns ON when the current position of the actuator falls within the parameter-set range.
Zone signal 2		ZONE2	
Position zone		PZONE	This signal turns ON when the current position of the actuator enters the range set in the position data table while moving to a position. This signal can be used with ZONE1, but the PZONE signal is effective only when moving to a set position.
Alarm		*ALM	This signal remains ON while the controller is normal, and turns OFF when an alarm occurs.
Moving		MOVE	This signal is ON while the actuator is moving (also during home return and push-motion operation).
Servo ON		SV	This signal is ON when the servo is ON.
Emergency stop output		*EMGS	This signal is ON when the controller is not in the emergency stop mode, and turns OFF when an emergency stop is actuated.
Teaching mode output		MODES	This signal turns ON when the actuator enters the teaching mode due to an input of the MODE signal. It turns OFF when the actuator returns to the normal mode.
Write complete		WEND	This signal is OFF immediately after switching to the teaching mode, and turns ON the moment the writing per the PWRT signal is completed. This signal also turns OFF when the PWRT signal turns OFF.
Current position number		PE0~PE6	This signal turns ON when the actuator completes moving to the target position in the solenoid mode.
Limit switch output		LS0~LS2	This signal turns ON when the current position of the actuator enters the positioning band (±) around the target position. If the home return has been completed, this signal is output even before a move command is issued or the servo is OFF.
Load output judgment status		LOAD	This signal turns ON when the in-certification-range command torque exceeds the threshold.
Torque level status signal		TRQS	This signal turns ON when the motor current reaches the threshold.
Minor failure alarm		*ALML	This signal is output when a message-level alarm generates.

(Note) In the table above, * indicates a negative logic signal.

PMEC
AMEC

PSEP
ASEP
DSEP

MSEP

ERC3

ERC2

PCON
-CA

PCON

ACON

SCON
-CA

MSCON

PSEL

ASEL

SSEL

XSEL

PS-24

Pulse
Motor

Servo
Motor
(24V)

Servo
Motor
(200V)

Linear
Servo
Motor

- Controller
- PMEC
- AMEC
- PSEP
- ASEP
- DSEP
- MSEP
- ERC3**
- ERC2
- PCON
- CA
- PCON
- ACON
- SCON
- CA
- MSCON
- PSEL
- ASEL
- SSEL
- XSEL
- PS-24
- Pulse Motor
- Servo Motor (24V)
- Servo Motor (200V)
- Linear Servo Motor

I/O Wiring Diagram

PIO 8-point Type (ERC3 and PLC Connected Directly)

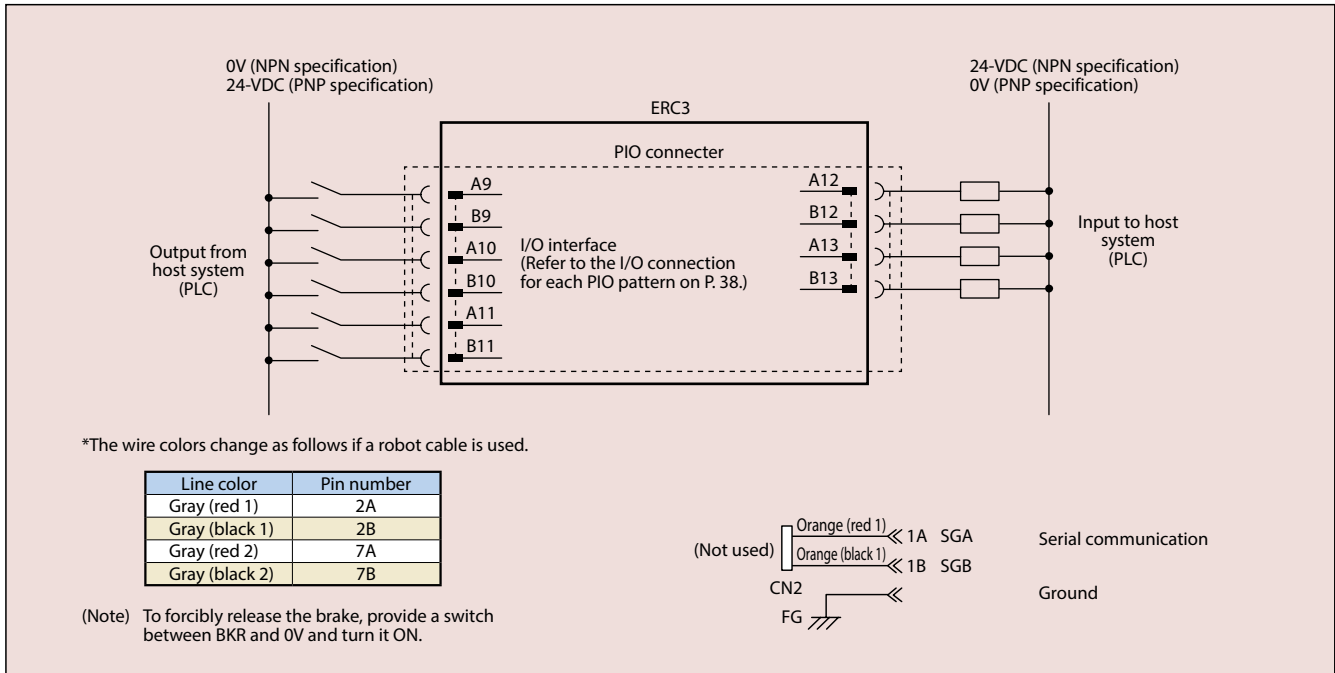

PIO Positioning Mode (Standard Type) (ERC3 and PLC Connected via PIO Converter)

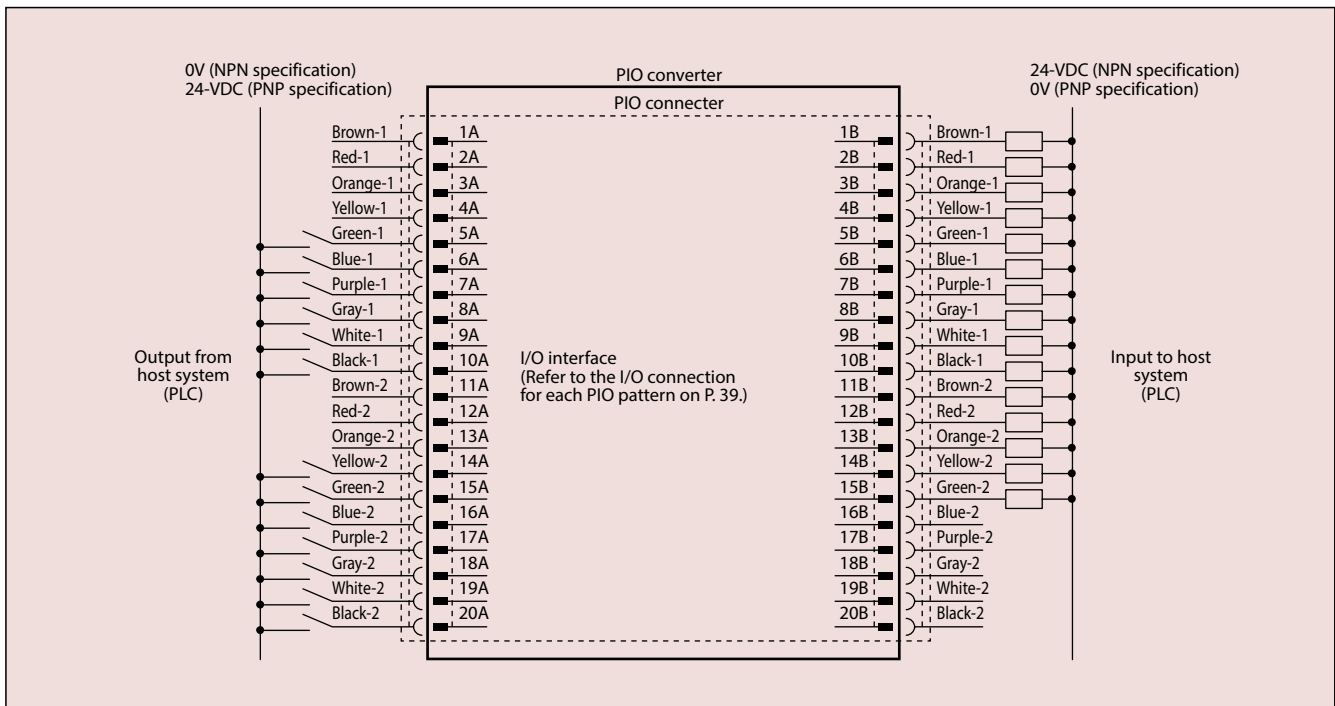

Pulse-train control mode

I/O specification (Pulse-train type)

Input Part

Code	Remarks
Differential input voltage range	26C31 or equivalent
Maximum cable length	Differential line driver method: 10m max. Open collector method (AK-04 used): 2m max.
Maximum number of input pulses	Differential line driver method: 200 kpps max. Open collector method (AK-04 used): 60kpps max.

* If the user-side I/O is of open collector type, use the AK-04.

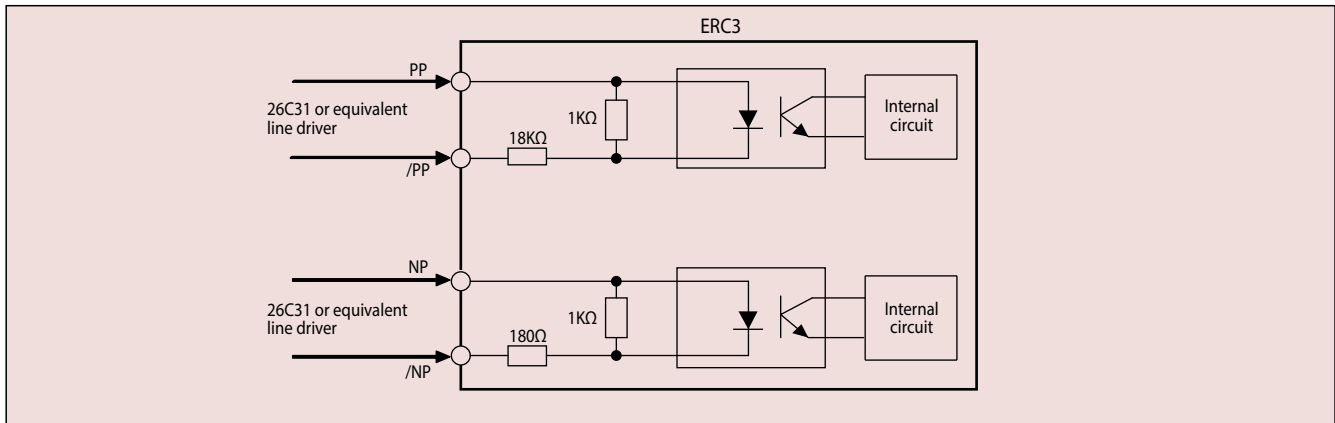

Pulse-train Control Circuit

Host Unit = Differential Type

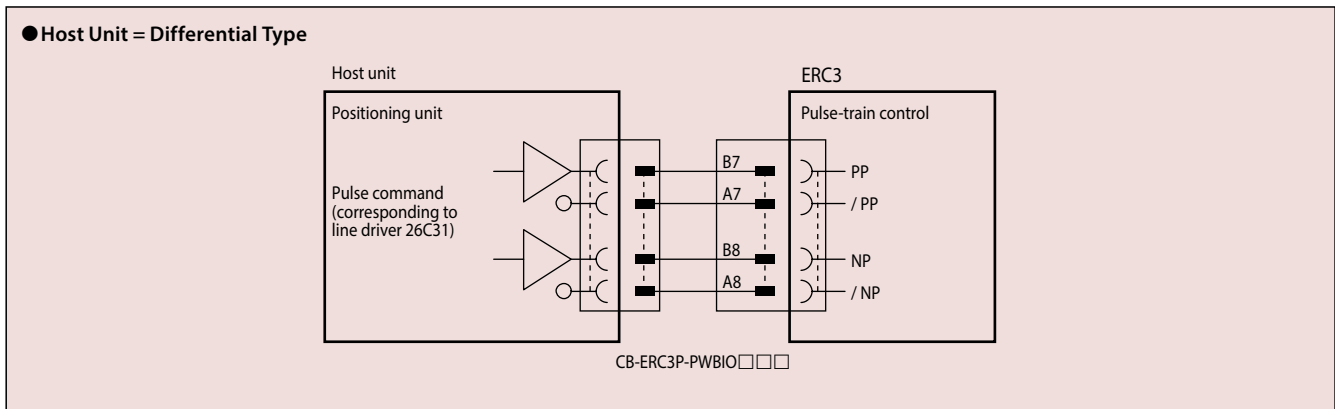

Host Unit = Open Collector Type

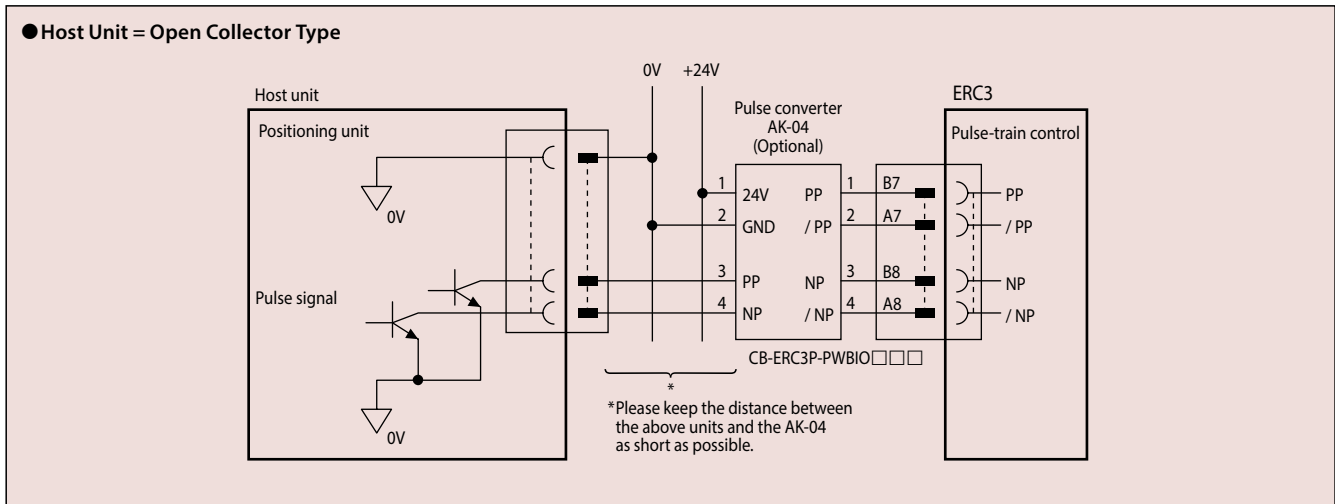

* The AK-04 (optional) is needed to input pulses.

* Use the same power supply for open collector input/output to/from the host and for the AK-04.

- Controller
- PMEC
- AMEC
- PSEP
- ASEP
- DSEP
- MSEP
- ERC3
- ERC2
- PCON
- CA
- PCON
- ACON
- SCON
- CA
- MSCON
- PSEL
- ASEL
- SSEL
- XSEL
- PS-24
- Pulse Motor
- Servo Motor (24V)
- Servo Motor (200V)
- Linear Servo Motor

- Controller
- PMEC
- AMEC
- PSEP
- ASEP
- DSEP
- MSEP
- ERC3
- ERC2
- PCON
- CA
- PCON
- ACON
- SCON
- CA
- MCON
- PSEL
- ASEL
- SSEL
- XSEL
- PS-24
- Pulse Motor
- Servo Motor (24V)
- Servo Motor (200V)
- Linear Servo Motor

I/O Signals for the Pulse-train Control Mode

The table below lists the signal assignments for the flat cable for the pulse-train control mode. Connect an external device (such as PLC) according to this table.

[1] Positioning Operation - PIO Pattern: 0

Pin number	Category	I/O number	Signal abbreviation	Signal name	Description of function
A1	Frame ground		FG	—	Frame ground.
B1	+24 V for control power supply		CP	—	+24 V of the control power supply is input.
A2				—	
B2	0 V for control power supply		GND	—	0 V of the control power supply.
A3	External brake release input		BK	—	This signal is used to release the brake externally. The brake is released when +24 V is input.
B3	+24 V for motor power supply		MP	—	+24 V of the motor power supply is input.
A4	Emergency stop input		EMG	—	Input signal for emergency stop.
B4	0 V for motor power supply		GND	—	+24 V of the motor power supply is input.
A5					
B5					
A6					
B6					
A7			/PP	Command pulse	
B7			PP	Command pulse	
A8			/NP	Command pulse	
B8			NP	Command pulse	
A9	Input	IN0	SON	Servo ON	The servo is ON while this signal is ON, and OFF while the signal is OFF.
B9		IN1	TL	Torque limit selection	When this signal is turned ON, the motor torque is limited to the value set by a parameter.
A10		IN2	HOME	Home return	Home return operation is performed when this signal is turned ON.
B10		IN3	RES	Reset	Present alarms are reset when this signal is turned ON.
A11		IN4	—		
B11		IN5	—		
A12	Output	OUT0	SV	Servo ON status	This signal turns ON when the servo is ON.
B12		OUT1	INP	Positioning complete	This signal turns ON when the amount of remaining travel pulses in the deviation counter falls within the positioning band.
A13		OUT2	HEND	Home return complete	This signal turns ON upon completion of home return.
B13		OUT3	*ALM	Controller alarm status	This signal turns ON when the controller is normal, and turns OFF when an alarm generates.

* indicates a negative logic signal. Negative logic signals are normally ON while the power is supplied, and turn OFF when the signal is output.

[2] Push-motion Operation - PIO Pattern: 1

Pin number	Category	I/O number	Signal abbreviation	Signal name	Description of function
A1	Frame ground		FG	—	Frame ground.
B1	+24 V for control power supply		CP	—	+24 V of the control power supply is input.
A2				—	
B2	0 V for control power supply		GND	—	0 V of the control power supply.
A3	External brake release input		BK	—	This signal is used to release the brake externally. The brake is released when +24 V is input.
B3	+24 V for motor power supply		MP	—	+24 V of the motor power supply is input.
A4	Emergency stop input		EMG	—	Input signal for emergency stop.
B4	0 V for motor power supply		GND	—	+24 V of the motor power supply is input.
A5					
B5					
A6					
B6					
A7			/PP	Command pulse	
B7			PP	Command pulse	
A8			/NP	Command pulse	
B8			NP	Command pulse	
A9	Input	IN0	SON	Servo ON	The servo is ON while this signal is ON, and OFF while the signal is OFF.
B9		IN1	TL	Torque limit selection	When this signal is turned ON, the motor torque is limited to the value set by a parameter.
A10		IN2	HOME	Home return	Home return operation is performed when this signal is turned ON.
B10		IN3	RES	Reset	This signal serves as a reset signal when the torque is not limited (torque TL signal is OFF). When this signal turns ON, present alarms are reset.
			DCLR	Deviation counter clear	This signal serves as a deviation counter signal when the torque is limited (torque TL signal is ON). This signal clears the deviation counter.
A11		IN4	—		
B11		IN5	—		
A12	Output	OUT0	SV	Servo ON status	This signal turns ON when the servo is ON.
B12		OUT1	INP	Positioning complete	This signal serves as a positioning complete signal when the torque is not limited (torque TL signal is OFF). It turns ON when the remaining travel pulses in the deviation counter are within the range of positioning band.
			TLR	Torque limited	This signal serves as a torque limited signal when the torque is limited (torque TL signal is ON). If the torque is limited, this signal turns ON when the torque limit is reached.
A13		OUT2	HEND	Home return complete	This signal turns ON upon completion of home return.
B13		OUT3	*ALM	Controller alarm status	This signal turns ON when the controller is normal, and turns OFF when an alarm generates.

* indicates a negative logic signal. Negative logic signals are normally ON while the power is supplied, and turn OFF when the signal is output.

Cable/Maintenance Parts

Power & I/O Cable for PIO Type

Model number **CB-ERC3P-PWBIO**

*Enter the cable length (L) into . Compatible to a maximum of 10 meters.
Ex: 080 = 8m

* The standard cable is a robot cable.

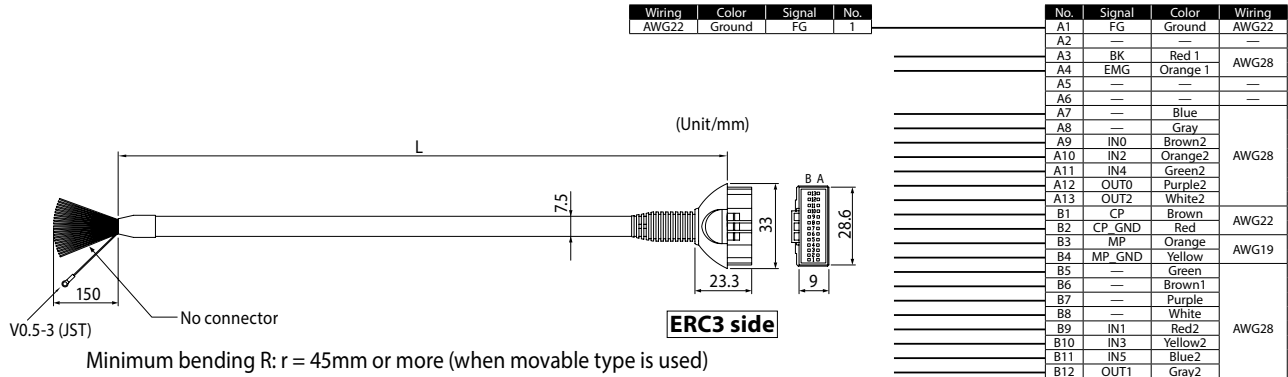

Power & I/O Cable for SIO Type

Model number **CB-ERC3S-PWBIO**

*Enter the cable length (L) into . Compatible to a maximum of 10 meters.
Ex: 080 = 8m

* The standard cable is a robot cable.

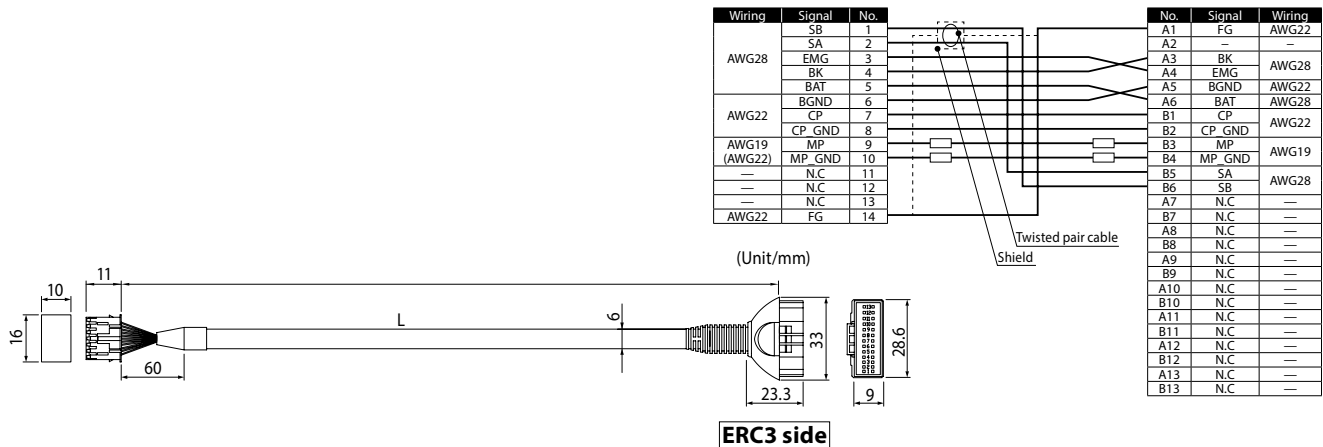

SIO Communication Cable (for Quick Teach)

Model number **CB-PST-SIO050**

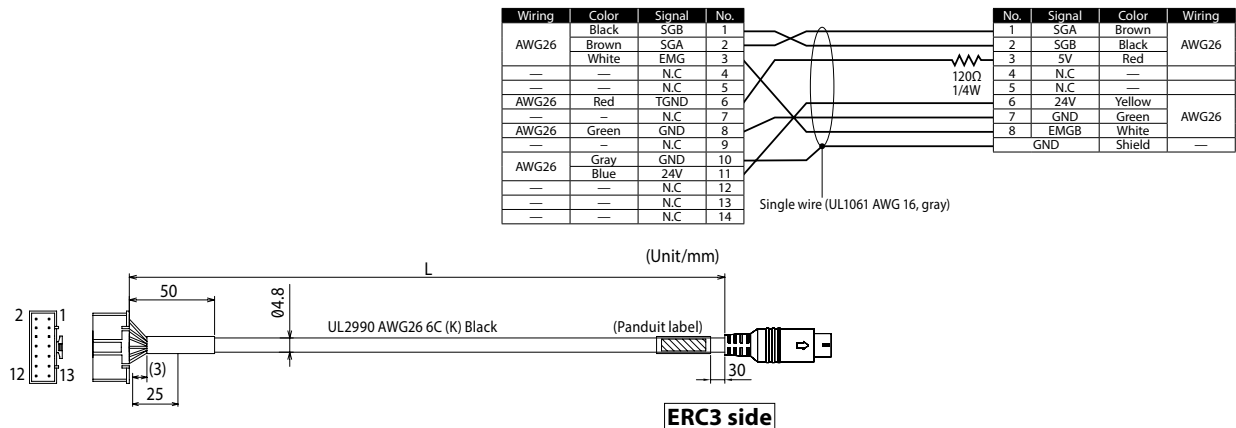

PIO Converter <RCB-CV>

Realizing controller functions of the next higher class with the ERC3 series

When connected to the PIO converter, the ERC3 series can demonstrate functions equivalent to the RCP4 controller "PCON-CA." Use the PIO converter if you want to configure a high-function system using the ERC3 series, use the absolute function or monitor the status of the actuator.



Features

Increased maximum number of positioning points

While the maximum number of positioning points supported by the ERC3 series' built-in controller is 16, it increases to 512 when the PIO converter is connected. Connecting the PIO converter also increases the numbers of I/O signals, allowing for complex controls and connection with peripheral equipment.

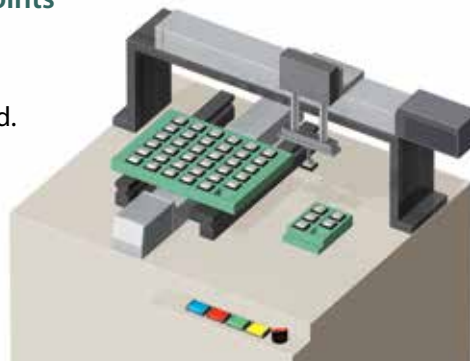

Supporting the simple absolute mode

The standard encoder of the ERC3 series is of incremental type. Once the power is turned off, therefore, the actuator's current position is lost and home return operation will be required next time the actuator is started. When the PIO converter is connected, the ERC3 lets you select the simple absolute mode. Home return operation is not required while the encoder is in the simple absolute mode, because the current position is retained.

In the simple absolute mode...

Home return operation is no longer required

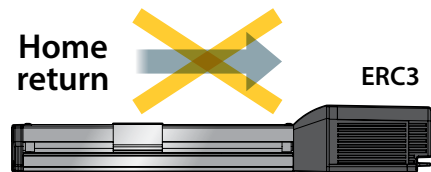

The actuator can be operated immediately after reconnecting the power.

* To use the simple absolute function, the PIO converter must be of the simple absolute type (equipped with the simple absolute battery) and the actuator must also be of the simple absolute specification.

* Among the different I/O types, only the serial communication type supports the simple absolute function.

Status LEDs indicating the operating status of the actuator

The PIO converter lets you check the following status using the status LEDs provided on the front panel (optional).

- Command current ratio level
- Alarm code
- PIO input terminal status
- PIO output terminal status

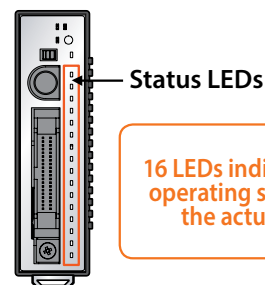

16 LEDs indicate the operating status of the actuator.

Calendar function for checking when errors occurred

The PIO converter has a calendar function that lets you check the details of past alarms, such as when each alarm occurred, by connecting the teaching pendant and PC software to the PIO converter. This function is useful when analyzing alarms.

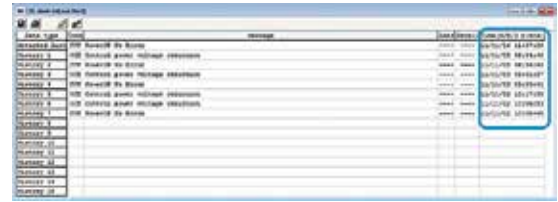

Brake release switch for at-will release of the brake

If your ERC3 actuator comes with a brake, the brake can be turned on/off freely using the brake release switch on the front panel of the PIO converter. To release the brake, turn the switch to the "RLS" position.

* If the actuator is used vertically, hold the actuator in place before releasing the brake.

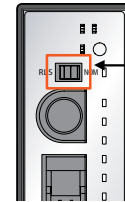

Brake release switch
Release the brake: RLS
Normal: NOM

Model Configuration

RCB Series	Type	I/O type	I/O cable length	Simple absolute function supported
CV Built-in power cutoff relay type (standard)	NP NPN specification (without monitoring LEDs)	0 No cable	(No entry) Simple absolute function not supported (for incremental specification only)	
CVG External power cutoff relay type	PN PNP specification (without monitoring LEDs)	2 With 2m cable	AB Simple absolute function supported (with simple absolute battery)	
	NPM NPN specification (with monitoring LEDs)	3 With 3m cable	ABUN Simple absolute function supported (without simple absolute battery)	
	PNM PNP specification (with monitoring LEDs)	5 With 5m cable		

* Select "NPM/PNM" if you want to use the functions of monitoring LEDs on the front panel.

Base Specifications

Item	Description	
Number of connected axes	ERC3 1 axis	
Power supply voltage	24VDC±10%	
Control power capacity	0.8A max.	
Heat output	1.3W	
Momentary power failure resistance	500µs max.	
Serial communication interface (SIO port)	RS485: 1 channel (conforming to Modbus protocol RTU/ASCII) / Speed: 9.6 to 230.4 kbps Actuators can be controlled via serial communication.	
External interface	Dedicated 24-VDC signal input/output (NPN or PNP selected)—Up to 16 input points, up to 16 output points / Cable length: 10 m max.	
Data setting/input method	PC software, touch-panel teaching pendant	
Operation Mode	Positioner mode	
Number of positions in positioner mode	Standard 64 points, maximum 512 points Note) Positioning points vary depending on the selected PIO pattern.	
LED display (installed on the front panel)	Status indicator LED - Steady green light: Servo ON / Blinking green light: Auto servo OFF / Steady red light: Alarm present Absolute battery status indicator LED - Green: Fully charged / Orange: Charging / Red: Not connected Absolute reset status LED - Green: Absolute reset complete / Red: Absolute reset not yet complete LED0 to LED15 (optional): 4 different statuses can be indicated by changing the switch setting. Command current ratio, alarm code, PIO input status, PIO output status	
Electromagnetic brake forced release switch (installed on the front panel)	Switched between NOM (standard) and BK RLS (forced releases)	
Isolation resistance	500VDC, 10MΩ or more	
Electric shock protection mechanism	Class I basic isolation	
Cooling method	Natural air cooling	
Environment	Ambient operating temperature	0 to 40°
	Ambient operating humidity	85%RH or less (non-condensing)
	Ambient storage temperature	-20 to 70° (excluding batteries)
	Operating altitude	Altitude 1000m or less
	Protection degree	IP20
	Vibration resistance	Number of vibrations: 10 to 57 Hz / Amplitude: 0.075 mm Number of vibrations: 57 to 150 Hz / Acceleration: 9.8 m/s ² Sweep time in X/Y/Z directions: 10 minutes / Number of sweeps: 10 times
Consumable parts	Weight	103g or less, or 287g (including 190g for the battery) or less for the simple absolute specification
	External Dimensions	25W×90H×98D
Consumable parts		RTC backup capacitor: Approx. 5 years* Drive-source cutoff relay: Approx. 100,000 actuations Absolute battery: Approx. 3 years

*When the power is supplied 12 hours a day at an ambient temperature of 40°C and the actuator is stopped (power turned off) 12 hours a day in an ambient temperature of 20°C.

Controller

PMEC
AMEC

PSEP
ASEP
DSEP

MSEP

ERC3

ERC2

PCON
-CA

PCON

ACON

SCON
-CA

MSCON

PSEL

ASEL

SSEL

XSEL

PS-24

Pulse Motor

Servo Motor (24V)

Servo Motor (200V)

Linear Servo Motor

ERC3 Controller

- Controller
- PMEC
AMEC
- PSEP
ASEP
DSEP
- MSEP
- ERC3**
- ERC2
- PCON
-CA
- PCON
- ACON
- SCON
-CA
- MSCON
- PSEL
- ASEL
- SSEL
- XSEL
- PS-24

Connection Example

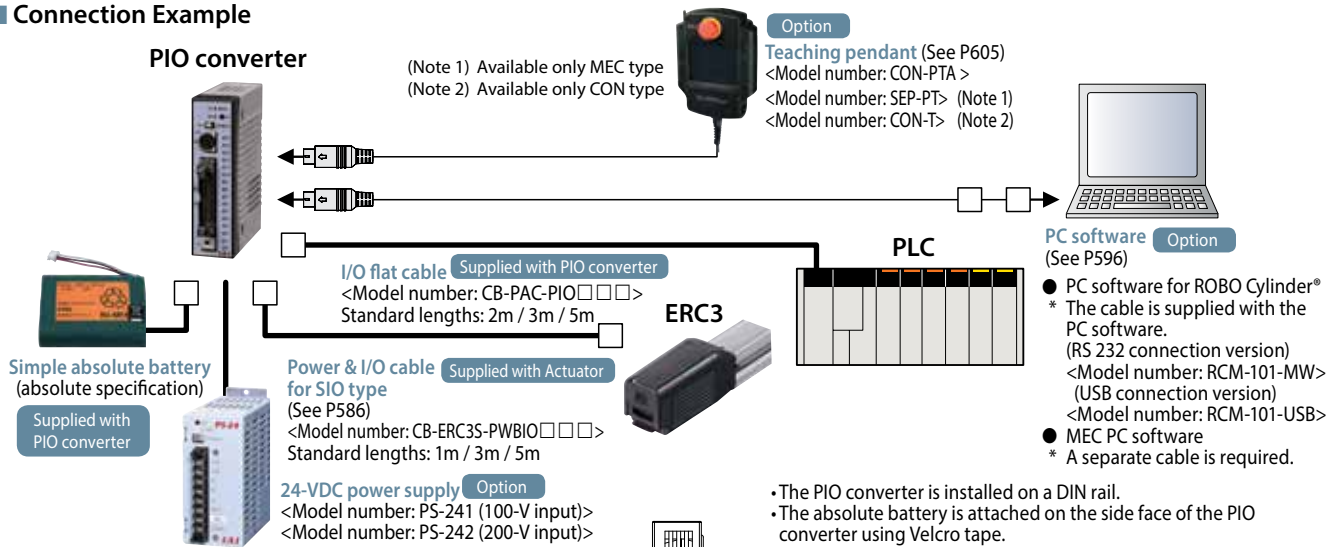

External Dimensions

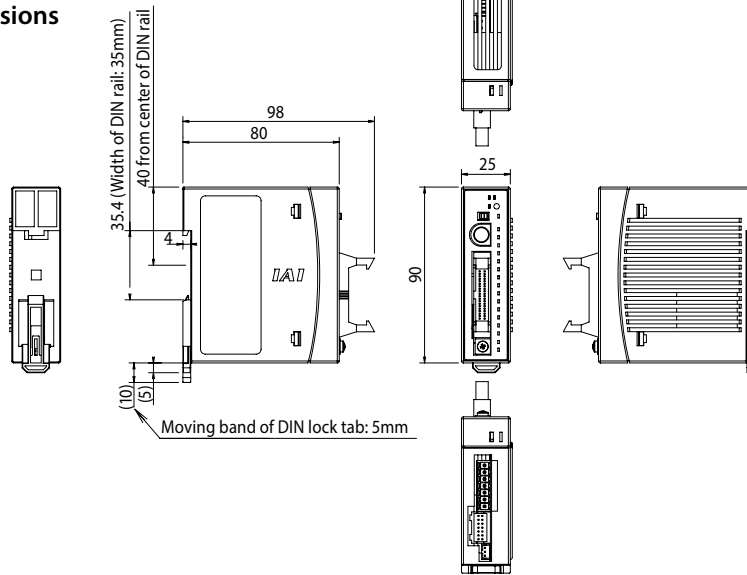

Standard Prices

*① in the model numbers below represents the number indicating I/O cable length.

Power cut-off relay	Monitoring LEDs	Positioning method	Model Numbers	Standard Prices
Built-in type	N/A	Incremental specification	RCB-CV-(NP/PN)-①	—
		Simple absolute specification (with battery)	RCB-CV-(NP/PN)-①-AB	—
		Simple absolute specification (without battery)	RCB-CV-(NP/PN)-①-ABUN	—
	Available	Incremental specification	RCB-CV-(NPM/PNM)-①	—
		Simple absolute specification (with battery)	RCB-CV-(NPM/PNM)-①-AB	—
		Simple absolute specification (without battery)	RCB-CV-(NPM/PNM)-①-ABUN	—
External type	N/A	Incremental specification	RCB-CVG-(NP/PN)-①	—
		Simple absolute specification (with battery)	RCB-CVG-(NP/PN)-①-AB	—
		Simple absolute specification (without battery)	RCB-CVG-(NP/PN)-①-ABUN	—
	Available	Incremental specification	RCB-CVG-(NPM/PNM)-①	—
		Simple absolute specification (with battery)	RCB-CVG-(NPM/PNM)-①-AB	—
		Simple absolute specification (without battery)	RCB-CVG-(NPM/PNM)-①-ABUN	—

I/O Flat Cable

Model number **CB-PAC-PIO**□□□

*□□□ indicates the cable length (L). A desired length can be specified up to 10m. Example: 080=8m

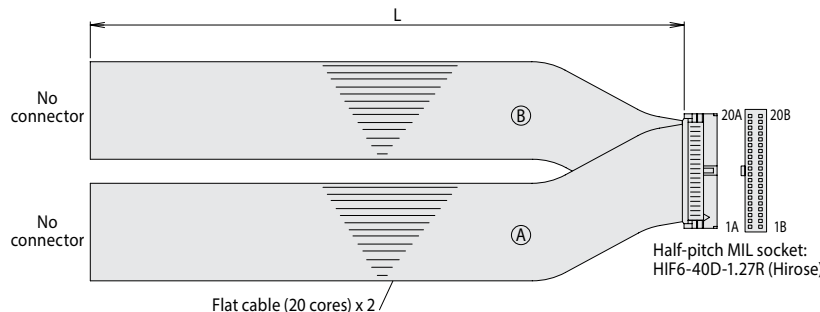

HIF6-40D-1.27R

No.	Signal name	Cable color	Wiring	No.	Signal name	Cable color	Wiring
1A	-	Brown - 1	Flat cable ② (crimped)	1B	OUT0	Brown - 3	Flat cable ② (crimped) AWG 28
2A	-	Red - 1		2B	OUT2	Red - 3	
3A	-	Orange - 1		3B	OUT2	Orange - 3	
4A	-	Yellow - 1		4B	OUT3	Yellow - 3	
5A	IN0	Green - 1		5B	OUT4	Green - 3	
6A	IN1	Blue - 1		6B	OUT5	Blue - 3	
7A	IN2	Purple - 1		7B	OUT6	Purple - 3	
8A	IN3	Gray - 1		8B	OUT7	Gray - 3	
9A	IN4	White - 1		9B	OUT8	White - 3	
10A	IN5	Black - 1		10B	OUT9	Black - 3	
11A	IN6	Brown - 2		11B	OUT10	Brown - 4	
12A	IN7	Red - 2		12B	OUT11	Red - 4	
13A	IN8	Orange - 2		13B	OUT12	Orange - 4	
14A	IN9	Yellow - 2		14B	OUT13	Yellow - 4	
15A	IN10	Green - 2		15B	OUT14	Green - 4	
16A	IN11	Blue - 2		16B	OUT15	Blue - 4	
17A	IN12	Purple - 2		17B	-	Purple - 4	
18A	IN13	Gray - 2		18B	-	Gray - 4	
19A	IN14	White - 2		19B	-	White - 4	
20A	IN15	Black - 2		20B	-	Black - 4	

589

ERC3

Options

Gateway Unit <RCM-EGW>



The ERC3 gateway unit lets you connect up to four ERC3 actuators to implement the gateway function. The gateway unit connects to a PLC or other host control system via a field network. It supports seven network protocols (CC-Link, DeviceNet, PROFIBUS-DP, MECHATROLINK-II, CompoNet, EtherCAT, EtherNet/IP).

- **Features**
 - Use the position adjustment switches on the front panel to jog the actuator
 - The brake release switch for each axis is provided on the front panel

Model Configuration

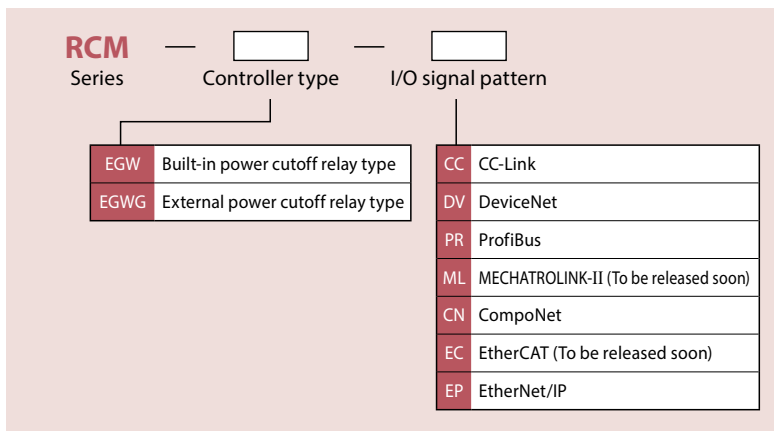

Base Specifications

Item	Description
Number of controlled axes	Up to 4 axes
Control/motor power-supply voltage	24 VDC ±10%
Control power capacity	1 A max.
Load current (per axis)	High-output setting enabled
	High-output setting disabled
Brake release power capacity (per axis)	0.15 A max.
Rush current (Note)	60 A max.
Cable length between actuator and gateway unit	10 m max. (A dedicated cable is used)
Number of positioning points	Up to 512 points (Unlimited in the simple direct mode or direct numerical specification mode) (Note) The number of positioning points varies depending on the operation pattern selected by the parameter.
Electromagnetic brake forced release	The electromagnetic brake for each axis can be released using the applicable brake forced release switch provided on the front panel.
Environment	Ambient operating temperature
	Ambient operating humidity
	Protection class

(Note) Approx. 50 μs of rush current flows after the power is turned on.

- Controller
- PMEC
AMEC
- PSEP
ASEP
DSEP
- MSEP
- ERC3
- ERC2
- PCON
-CA
- PCON
- ACON
- SCON
-CA
- MSCON
- PSEL
- ASEL
- SSEL
- XSEL
- PS-24
- Pulse Motor
- Servo Motor (24V)
- Servo Motor (200V)
- Linear Servo Motor

Operation Mode

Operation pattern	Description
Positioner 1/simple direct mode (*)	In the positioner 1 mode, position data of up to 512 points can be registered to stop the actuator at any of the registered positions. The current position can also be monitored. In the simple direct mode, the target position can be specified directly by entering a value. The current position can also be monitored.
Direct numerical specification mode (*)	The target position, speed, acceleration/deceleration and push-current limiting value can be each specified by entering a value. In addition to the current position, the current speed and command current value can also be monitored.
Positioner 2 mode (*)	In this mode, the actuator is operated using the position data of up to 512 points set in the position table. The current position cannot be monitored. The functions available in this mode are the same as those provided in the positioner 1 mode, except that less amount of data can be sent/received.
Positioner 3 mode (*)	In this mode, the actuator is operated using the position data of up to 256 points set in the position table. The current position cannot be monitored. The amount of data sent/received in this mode is further less than that in the positioner 2 mode, and the actuator is controlled using the minimum signals required for positioning.
Remote I/O	The same six functions (Note 1) available with the PIO specification (CON type) can be controlled. The same two functions (Note 2) available with the PIO specification (MEC type) can be controlled.

Note 1) Switched using the ERC3's PIO pattern parameter.

Note 2) Switched using the ERC3's operation pattern parameter.

(*) For the CON type only. (Cannot work with the MEC type.)

Control Signals in the Remote I/O Mode

The table below lists the ERC3 functions that can be controlled in each type.

CON Type Specifications

O: Supported X: Not supported

ROBO Cylinder function	Operation pattern (PIO pattern)					
	0	1	2	3	4	5
	Positioning mode	Teaching mode	256-point mode	512-point mode	Solenoid valve mode 1	Solenoid valve mode 2
Home return operation	O	O	O	O	O	X (Note 1)
Positioning operation	O	O	O	O	O	O
Speed & acceleration/deceleration setting	O	O	O	O	O	O
Pitch feed (inching)	O	O	O	O	O	O
Push-motion operation	O	O	O	O	O	X
Speed change while moving	O	O	O	O	O	O
Operation at different acceleration/speed	O	O	O	O	O	O
Pause	O	O	O	O	O	O (Note 2)
Zone signal output	O	O	O	X	O	O
PIO pattern selection	O	O	O	O	O	O

Note 1) Home return is performed with the first move command.

Note 2) Supported if ERC3 Parameter No. 27, "Move command type" is set to "0."

MEC Type Specifications

ROBO Cylinder function	Operation pattern	
	1-input, 2-point move	2-input, 3-point move
Home return operation	X (Note 1)	X (Note 1)
Positioning operation	O	O
Speed & acceleration/deceleration setting	O	O
Pitch feed (inching)	X	X
Push-motion operation	O	O
Speed change while moving	X	X
Operation at different acceleration/speed	O	O
Pause	X	O
Zone signal output	X	X

Note 1) Home return is performed with the first move command.

Example of Connection

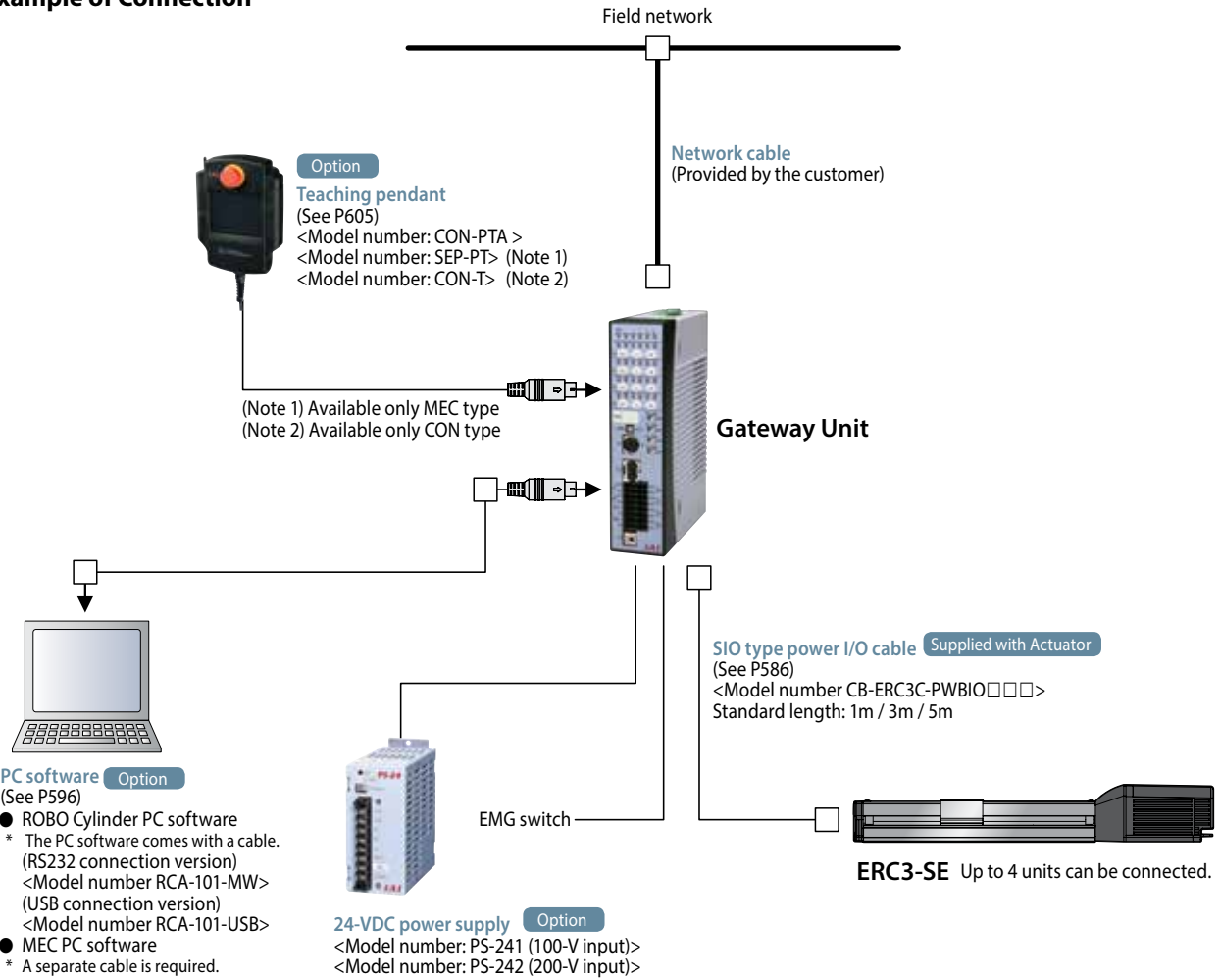

External Dimensions

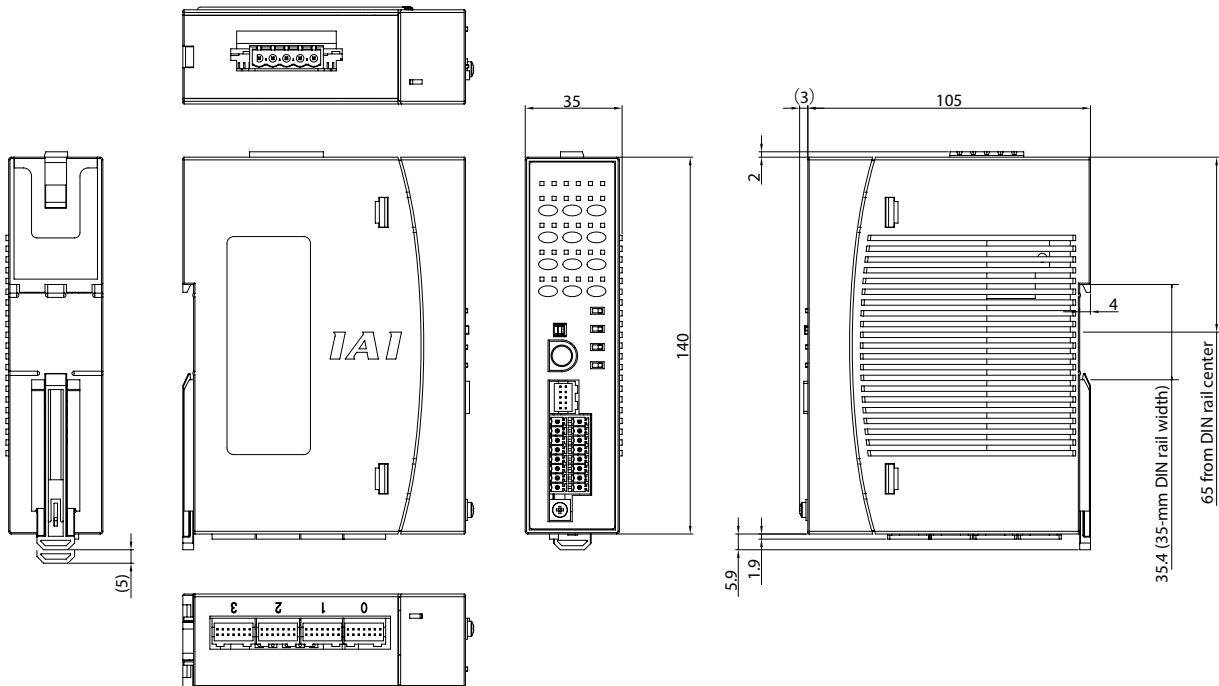

Controller

PMEC
AMEC

PSEP
ASEP
DSEP

MSEP

ERC3

ERC2

PCON
-CA

PCON

ACON

SCON
-CA

MSCON

PSEL

ASEL

SSEL

XSEL

PS-24

Pulse Motor

Servo Motor (24V)

Servo Motor (200V)

Linear Servo Motor

Notes on Selecting the Teaching Pendant and PC Software

With the ERC3 series, usable teaching pendant and PC software vary depending on the controller type (CON type/MEC type). Refer to P.5 for controller types.

Teaching pendant

Controller type	CON-PTA	RCM-PST	SEP-PT
CON type	○	△	—
MEC type	○	○	○

PC software

Controller type	RCM-101-MW	RCM-101-USB	MEC PC software
CON type	○	○	—
MEC type	—	—	○

○: All functions are supported / △: Limited functions are supported (home return, servo ON/OFF, JOG+, JOG-, stop (press and hold to reset alarms))

Options

Quick Teach <RCM-PST>



A teaching pendant equipped with intuitive operation buttons and acceleration/speed knobs that can be used easily even by mechanical engineers and those who never operated a robot before.

- Features**
 - User-friendly panel sheet switches and knobs let you complete the settings in no time.
 - The small pendant can be held in a hand.
 - Separate power-supply unit



Model configuration

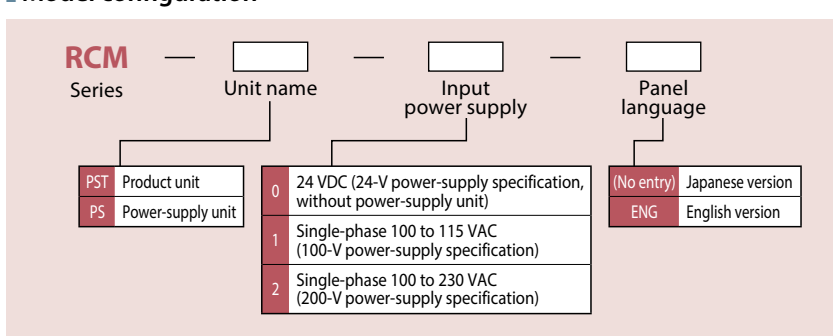

Base Specifications

Item	Description		
Product name	24-VDC specification	100-VDC specification	200-VDC specification
Product model	RCM-PST-0	RCM-PST-1	RCM-PST-2
Product configuration	Teaching pendant	RCM-PST-0	
	Power-supply unit	(Teaching pendant only)	RCM-PS-1
Power supply voltage	24 VDC±10% (DC 21.6V to DC 26.4V)	Single-phase 100 to 115 VAC±10% (AC 90V to AC 126.5V)	Single-phase 100 to 230 VAC±10% (AC 90V to AC253 V)
Load capacity (motor power capacity) of connected ERC3 (Note 1)	ERC3	Rated	
	42P	1.2A	2.2A
	56P	1.2A	2.2A
Number of controlled axes	1 axis		
Environment conditions	Operating temperature range: 0 to 40°C Operating humidity range: 85% RH or less (non-condensing) Storage temperature range: -20°C to 70°C		
Protection degree	IP20		
Power-supply frequency	50Hz/60Hz		
Pollution degree	Pollution degree 2		
Leak current	—	0.5mA max	0.75mA max
Cooling method	Natural air cooling		
Cable length	Actuator cable: 10m or less AC cable: 2m SIO communication cable (optional): 5m		
Product size	65 (W) x 157 (H) x 21.6 (D)	65 (W) x 157 (H) x 64.4 (D)	
Weight *Excluding connection cables	120g	540g	535g
Standard price	—	—	—

Note 1) If an ERC3 actuator whose high-output setting is enabled is used to perform test run using the Quick Teach connected to the above power-supply unit, the ERC3 may not operate as specified. (Position data can be edited without problems.)
If test run is performed with the actuator's high-output setting enabled, connect a 24-VDC power supply to the Quick Teach. In this case, disconnect the power-supply unit.

■ Connection Example

■ Supplying power from the Quick Teach to the ERC3

<Using a 24-VDC power supply>

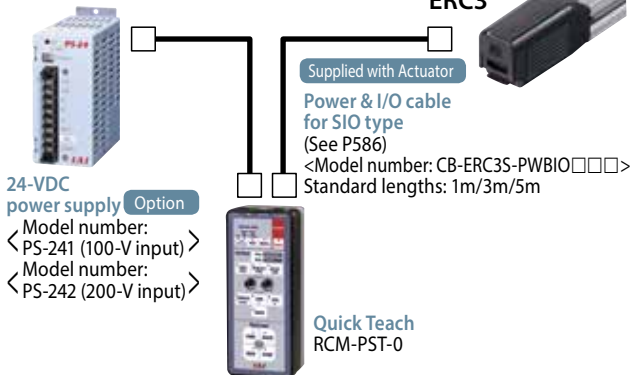

<Using a 100/200-VAC power supply>

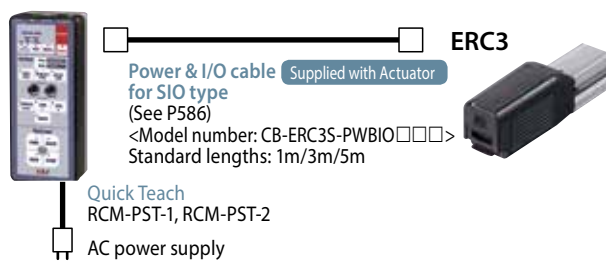

■ Connecting the Quick Teach to the ERC3 supplied with power

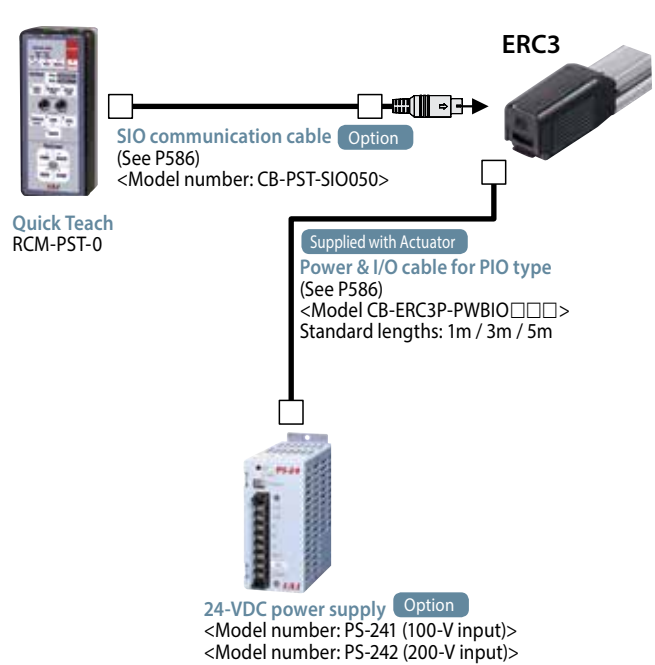

Name and Function of Each Part/External Dimensions

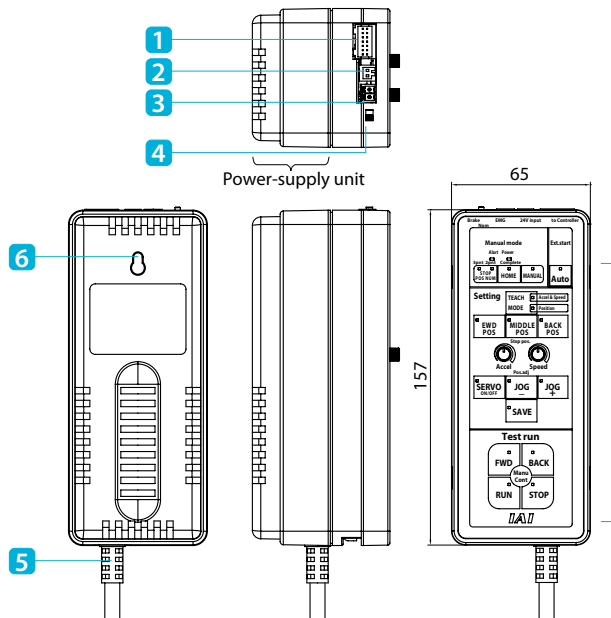

<Quick Teach and Model Numbers>

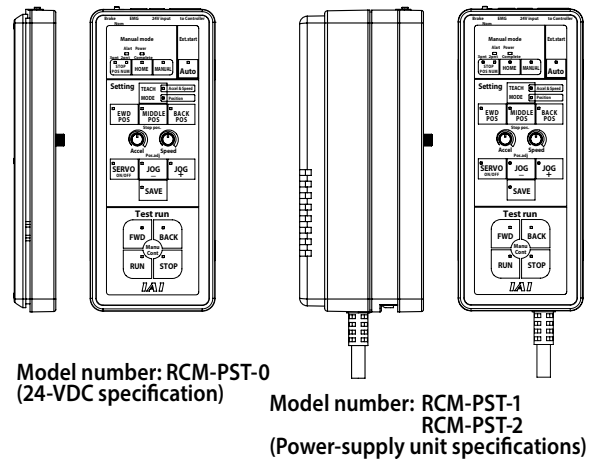

Shown above are the external dimensions of the Quick Teach with power-supply unit (model number: RCM-PST-1/2). The 24-V power-supply specification (model number: RCM-PST-0) has no power-supply unit.

- 1 ERC3 connector..... For cable connection with the ERC3.
- 2 External 24-V connector 24 VDC±10%. * Supplied with a plug connector.
- 3 Emergency stop connector Connect an emergency stop switch. * Supplied with a plug connector.
- 4 Brake switch Forced release switch for an actuator with brake.
- 5 AC input cable Single-phase 100 or 230-V input. * Varies depending on the product.
- 6 Wall-mounting hook..... The hook can be secured with M3 or equivalent screws or bolts (screw head size: ø6 or less).
- 7 Operation switches..... Panel sheet switches

- Controller
- PMEC
AMEC
- PSEP
ASEP
DSEP
- MSEP
- ERC3
- ERC2
- PCON
-CA
- PCON
- ACON
- SCON
-CA
- MSCON
- PSEL
- ASEL
- SSEL
- XSEL
- PS-24
- Pulse Motor
- Servo Motor (24V)
- Servo Motor (200V)
- Linear Servo Motor

Options

Touch-panel Teaching Pendant for Position Controller CON-PTA/PDA/PGAS

Adopting an easy-to-use interactive touch-panel menu screen, these simple data devices can be operated without consulting to the manuals.



1. Color screen for greater ease of view
2. Supporting the takt time minimization function and maintenance information checking/input functions.
3. Position, parameters and other data can be saved in a SD card
4. Built-in clock function records the date & time of each event; data can then be saved in a SD card.

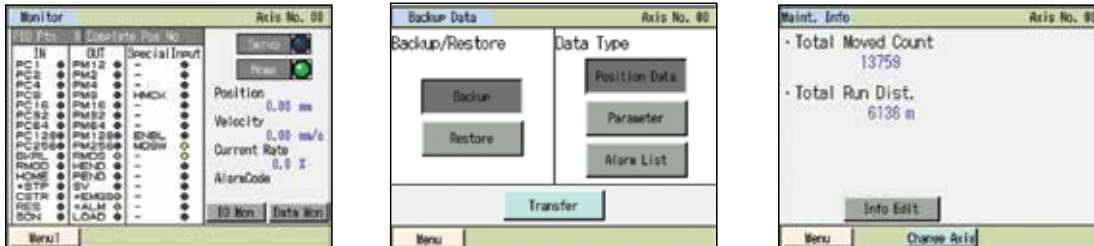

Model Numbers/Specifications

Item	Description		
	CON-PTA-C-ENG	CON-PDA-C-ENG	CON-PGAS-C-S-ENG (set)
Model number	CON-PTA-C-ENG	CON-PDA-C-ENG	CON-PGAS-C-S-ENG (set)
Type	Standard type	Enable switch type	Safety-category compliant type
Connectable controllers	ACON/PCON/SCON/RACON/RPCON/MSCON/ASEP/PSEP/MSEP/DSEP/AMEC/PMEC /ERC2 (*1) /ERC3		
3-position enable switch	×	○	○
Functions	<ul style="list-style-type: none"> • Position data input/editing • Moving function (moving to set positions, jogging/inching) • Parameter editing • Monitoring (current position, current speed, I/O signals, alarm code, alarm generation time) • Saving/reading data to/from external SD cards (position data parameters, alarm list) • Takt time minimization function • Maintenance information (total number of movements, total distance travelled, etc.) 		
Display	65,536 colors (16-bit colors), white LED backlight		
Ambient operating temperature/humidity	0 to 40°C, 85% RH or less (Non-condensing)		
Environmental resistance	IP40 or equivalent		
Mass	Approx. 570g	Approx. 600g	
Cable length	5m		
Accessories	Stylus	Stylus	Stylus, TP adapter (Model number: RCB-LB-TGS) Dummy plug (Model number: DP-4S) Controller cable (Model number: CB-CON-LB005)
Standard price	—		

*1 Among the ERC2 series, only the actuators bearing 4904 or greater number stamped on the serial number label can be connected.

Name of Each Part

■ Name of Each Part/External Dimensions

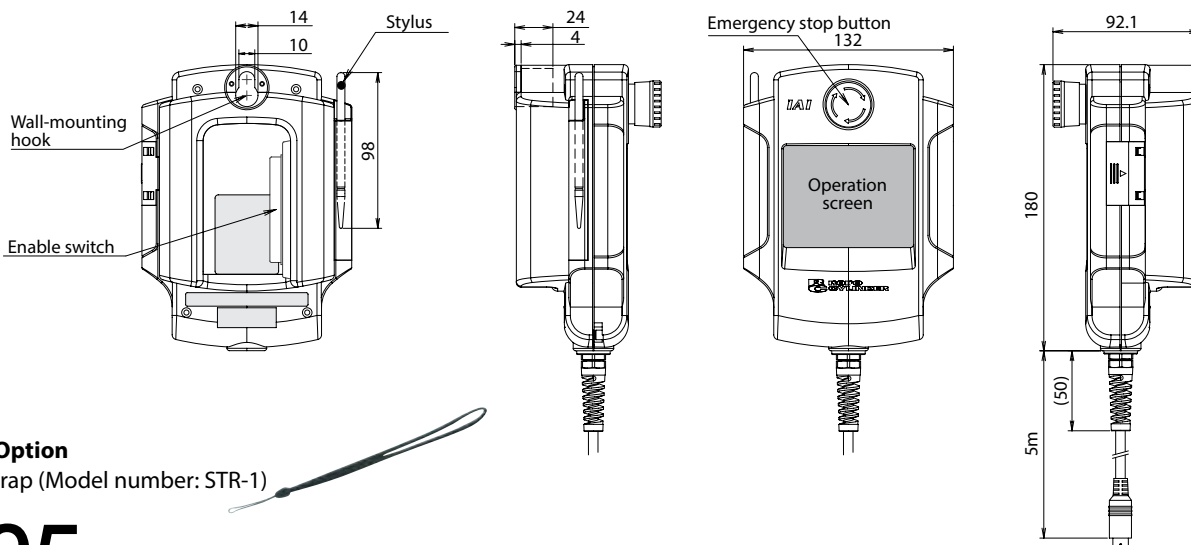

■ Option

- Strap (Model number: STR-1)

595

ERC3

Options

Touch-panel Teaching Pendant for Position Controller SEP-PT

SEP-PT version 3.00 or later is supported.

- Features Teaching device offering position input, test run, monitoring and other functions.
* This teaching pendant can be used when the ERC3's controller type is set to "MEC type."

Specifications

Item	SEP-PT
Data input	○
Actuator operation	○
Ambient operating temperature/humidity	Temperature 0 to 40°C, humidity 85%RH or less
Operating ambience	Free from corrosive gases or significant powder dust.
Protection degree	IP40
Mass	Approx. 550g
Cable length	5m
Display	3-color LED touch panel with backlight
Standard price	—

Configuration

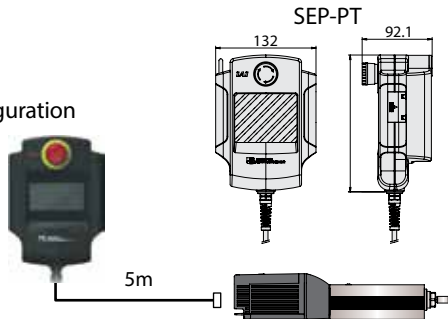

PC software version 8.03.00.00 or later is supported.

PC Software (Windows Only)

- Features This startup support software provides functions to input positions, perform test runs and monitor data, among others. Incorporating all functions needed to make adjustments, this software helps shorten the initial startup time.
* This software can be used when the ERC3's controller type is set to "CON type."

Supported Windows OS:
2000 SP4 or later / XP SP2 or later / Vista / 7

Model number RCM-101-MW

(With external device communication cable + RS232 conversion unit)

Configuration

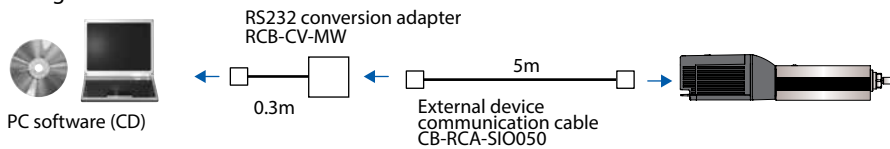

Model number RCM-101-USB

(With external equipment communication cable + USB conversion adapter + USB cable)

Configuration

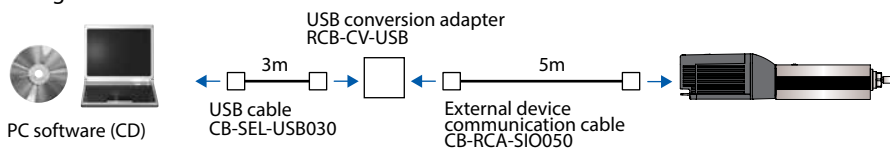

MEC PC Software

You can change the stop position data, perform test run and do many other things on a PC using the MEC PC software. This software also lets you use the middle stop function, perform push-motion operation, change the coordinates, etc., with ease. The MEC PC software can be downloaded on the IAI's website.

The MEC PC software can be used with the version 2.00.00.00 or later.

IAI's website: www.intelligentactuator.com

* This software can be used when the ERC3's controller type is set to "MEC type."

The cable supplied with the above "PC software (RCM-101-MW/RCM-101-USB)" can be used to connect the PC and ERC3 series. To purchase a cable separately, select an appropriate cable/adaptor by referring to the table below.

PC connection method	Model	Name	Price
RS232	CB-RCA-SIO050	External device communication cable	—
	RCB-CV-MW	RS232 conversion adapter	—
USB	CB-RCA-SIO050	External device communication cable	—
	RCB-CV-USB	USB conversion adapter	—
	CB-SEL-USB030	USB cable	—

- Controller
- PMEC
AMEC
- PSEP
ASEP
DSEP
- MSEP
- ERC3
- ERC2
- PCON
-CA
- PCON
- ACON
- SCON
-CA
- MSCON
- PSEL
- ASEL
- SSEL
- XSEL
- PS-24



ERC2

■ Model: NP / PN / SE

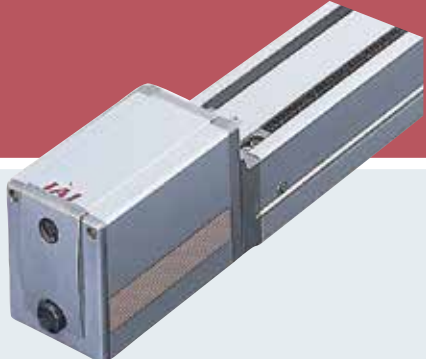
Controller module of controller-integrated actuator



List of Models

I/O type		NP	PN	SE
Name		PIO type (NPN Specification)	PIO type (PNP Specification)	Serial Communication Type
External View				
Description		Controller that moves by designating position numbers with NPN PIO via PLC.	Controller that moves by designating position numbers with PNP PIO via PLC.	Controller that is used by connecting to the field network via the gateway unit.
Position points		16 points	16 points	64 points
Standard Price	SA6C		—	
	SA7C		—	
	RA6C		—	
	RA7C		—	
	RGS6C		—	
	RGS7C		—	
	RGD6C		—	
	RGD7C		—	

Model

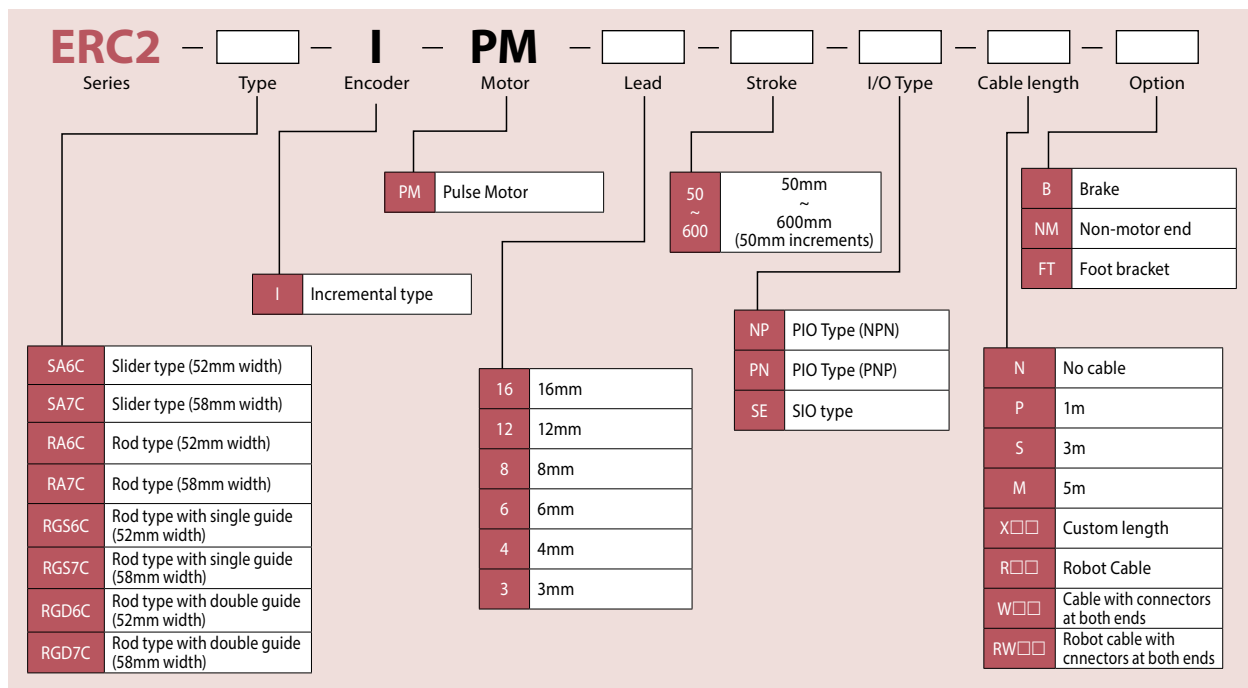

System configuration

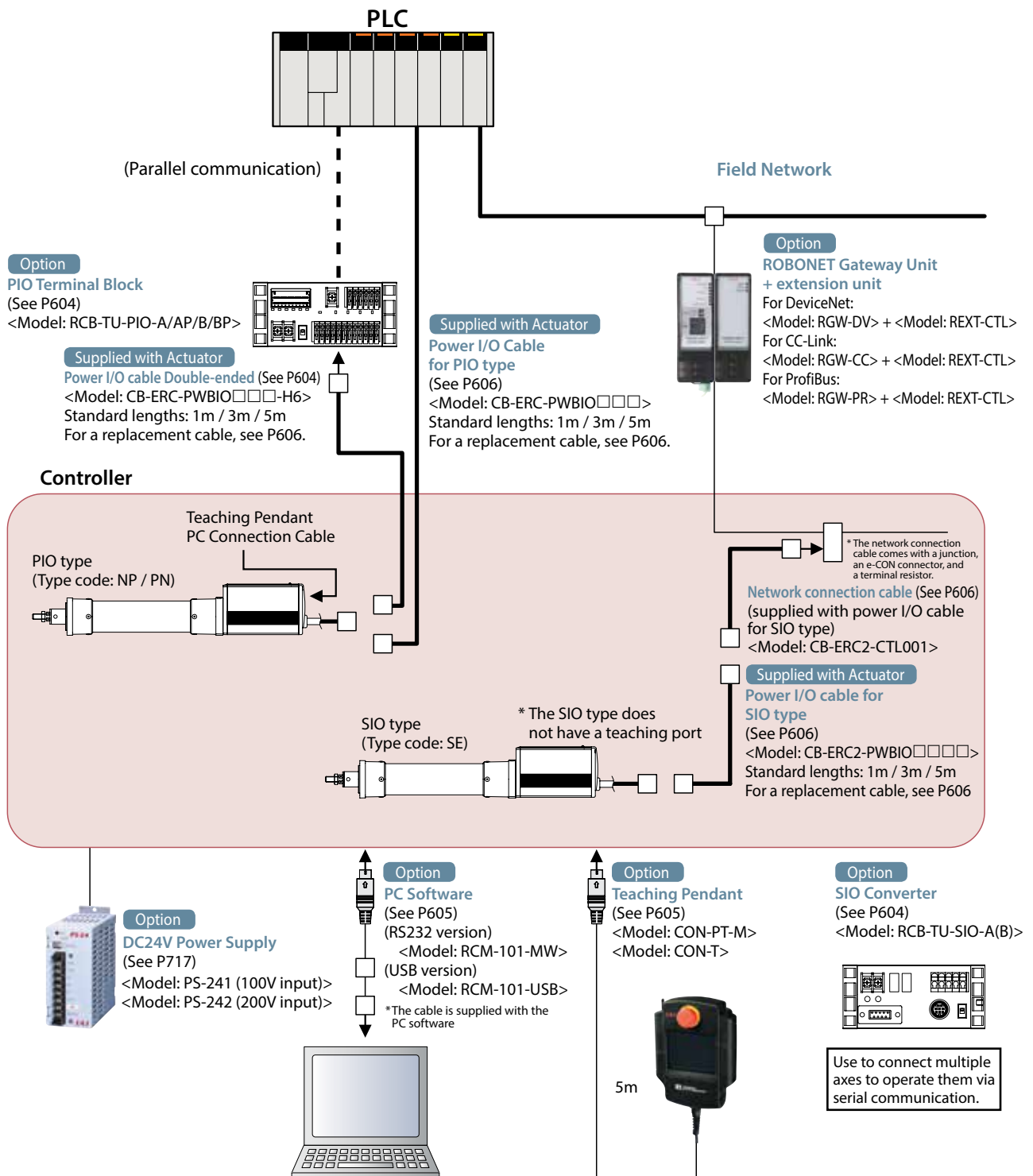

PMEC
AMEC

PSEP
ASEP
DSEP

MSEP

ERC3

ERC2

PCON
-CA

PCON

ACON

SCON
-CA

MSCON

PSEL

ASEL

SSEL

XSEL

PS-24

Wiring Diagram to Connect to a PC

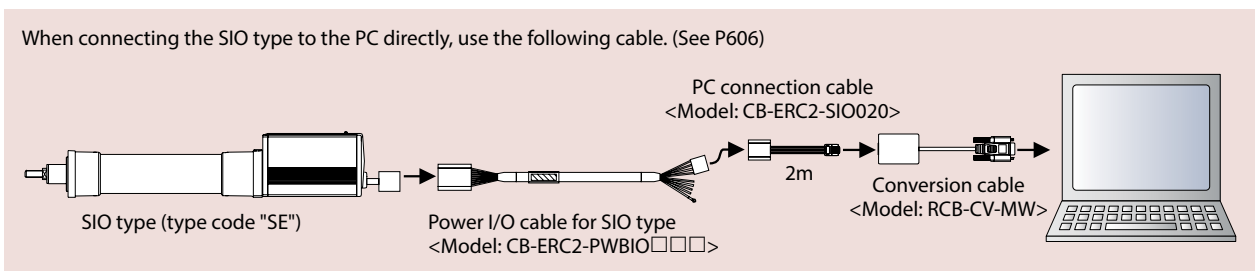

Pulse
Motor

Servo
Motor
(24V)

Servo
Motor
(200V)

Linear
Servo
Motor

- Controller
- PMEC
AMEC
- PSEP
ASEP
DSEP
- MSEP
- ERC3
- ERC2**
- PCON
-CA
- PCON
- ACON
- SCON
-CA
- MSCON
- PSEL
- ASEL
- SSEL
- XSEL
- PS-24

I/O Specification (PIO type)

Input section External input specifications

Item	Specifications
Input points	6 points
Input voltage	DC24V +/-10%
Input current	4mA/circuit
Leak current	Max. 1mA/point
Operating voltage	ON voltage: Min. 18V (3.5mA) OFF voltage: Max. 6V (1mA)

NPN Specifications

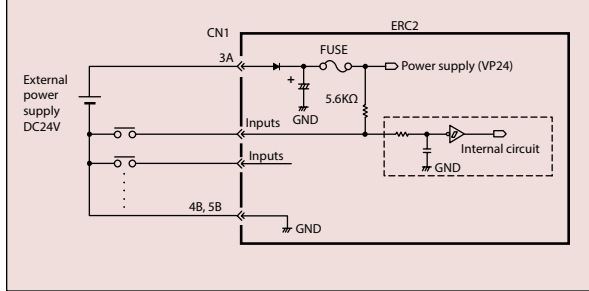

PNP Specifications

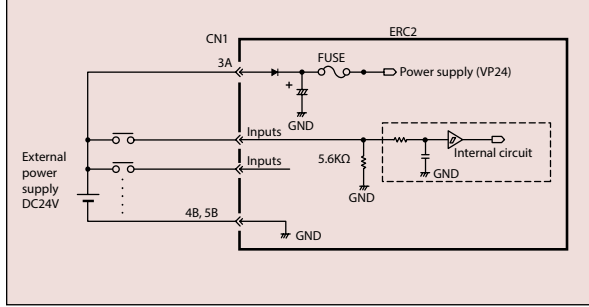

Output section External input specifications

Item	Specifications
Input points	4 points
Nominal load voltage	DC24V
Max. current	60mA/point
Remaining voltage	2V or less
Short-circuit, reverse voltage, protection	Fuse resistance (27Ω.0.1W)

NPN Specifications

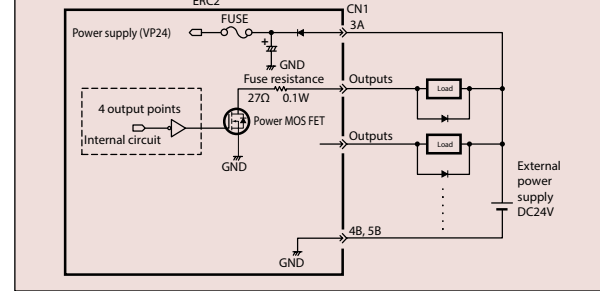

PNP Specifications

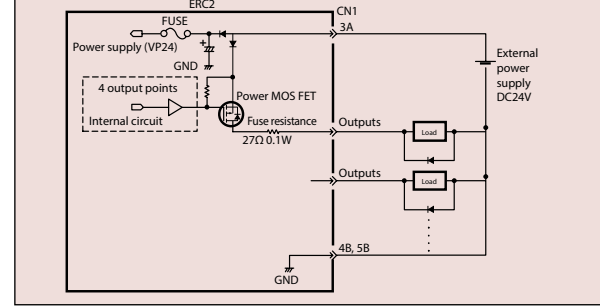

Table of I/O Signals (PIO type)

Parameter (PIO pattern select)	PIO pattern	Pin No.
0	8-point type	A standard specification providing eight positioning points, plus a home return signal, zone signal, etc. (The parameter has been set to this pattern prior to the shipment.)
1	3-point type (Solenoid valve type)	Simply turn ON three signals of ST0 to ST2 to move the actuator to the corresponding positions (0 to 2), just like you do with solenoid valves (This allows for easy conversion from air cylinders).
2	16-point type (Zone signal type)	Can be positioned for up to 16 points. (Same as the 8-point type, except that this pattern provides no home return signal.)
3	16-point type (Position zone signal type)	A 16-point pattern with a position zone signal instead of a zone signal.

Pin No.	Classification	Wire color	Parameters (select PIO pattern)			
			0 Conventional type	1 3-point type (Solenoid valve type)	2 16-point type (Zone signal type)	3 16-point type (Position zone signal type)
1A	PIO	Orange (Red 1)	SGA			
1B		Orange (Black 1)	SGB			
2A	Signal	Light Blue (Red 1)	EMS1			
2B	Signal	Light Blue (Black 1)	EMS2			
3A	24V	White (Red 1)	24V			
3B	0V	White (Black 1)	BLK			
4A	24V	Yellow (Red 1)	MPI			
4B	0V	Yellow (Black 1)	GND			
5A	24V	Pink (Red 1)	MPI			
5B	0V	Pink (Black 1)	GND			
6A	Input	Orange (Red 2)	PC1	ST0	PC1	PC1
6B		Orange (Black 2)	PC2	ST1	PC2	PC2
7A		Light Blue (Red 2)	PC4	ST2	PC4	PC4
7B		Light Blue (Black 2)	HOME	—	PC8	PC8
8A	Input	White (Red 2)	CSTR	RES	CSTR	CSTR
8B		White (Black 2)	* STP	* STP	* STP	* STP
9A	Output	Yellow (Red 2)	PEND	PE0	PEND	PEND
9B		Yellow (Black 2)	HEND	PE1	HEND	HEND
10A		Pink (Red 2)	ZONE	PE2	ZONE	ZONE
10B		Pink (Black 2)				

Signals marked with an asterisk (*) (ALM/STP) are negative logic signals so they are normally on.

Signal Names

Classification	Signal Name	Signal Abbreviation	Function Overview
SIO	Serial communication	SGA SGB	Used for serial communication.
24V 0V	Emergency stop	EMS1 EMS2	These signals are wired to enable the emergency stop switch on the teaching pendant (see P521).
Input	Brake release	BKR	By connecting to 0V (150mA needed) the brake is forcibly released.
	Command position No.	PC1 PC2 PC4 PC8	Designates the position number using 4-bit binary signals (or 3-bit binary signals if the 8-point PIO pattern is selected). (Example) Position 3 → Input PC1 and PC2 Position 7 → Input PC1 and PC2 and PC4
	Position movement	ST0 ST1 ST2	Turn the ST0 signal on to move the actuator to position 0. Same for ST1 and ST2 (Operation can be started with these signals alone. No need to input a start signal).
	Home return	HOME	Home-return operation starts at the leading edge of this signal.
	Start	CSTR	Input a command position number signal and turn this signal ON, and the actuator will start moving to the specified position
	Reset	RES	Turning this signal ON resets the alarms that are present. When it is paused (*STP is off), it is possible to cancel the residual movement.
	Pause	* STP	Normal operation is allowed while this signal is ON (negative logic) The actuator starts to decelerate to a stop at the ON → OFF leading edge of this signal.
Output	Positioning complete	PEND	This signal turns ON once the actuator has moved to the target position and completed the positioning by entering the specified positioning band. Used to determine if positioning has completed.
	Complete position No.	PE0 PE1 PE2	PE0 is output upon completion of movement to position 0. Same for PE1 and PE2. (These signals are valid only when the 3-point PIO pattern is selected.)
	Home return complete	HEND	This signal turns ON upon completion of home return.
	Zone	ZONE	This signal turns ON upon entry into the zone signal range set by parameters.
	Position zone	PZONE	This signal turns ON upon entry into the zone signal range set in the position table.
	Alarm	* ALM	The signal remains ON in normal conditions and turns OFF upon generation of the alarm (negative logic). Synchronized with the LED at the top of the motor cover (green: normal state, red: alarm on).

Signals marked with an asterisk (*) (ALM/STP) are negative logic signals so they are normally on.

Specification Table

Specification	Details	
Type	PIO specification (NP / PN)	SIO specification (SE)
Control method	Low field vector control (patent pending)	
Positioning command	Position No. designation	Position No. designation / Direct value designation
Position No.	Max. 16 points	Max. 64 points
Backup memory	Position number data and parameters are stored in nonvolatile memory. Serial EEPROM with a rewrite life of 100,000 times	
PIO	6 dedicated input points/4 dedicated output points	None
Electromagnetic brake	Built-in circuit DC24V±10 0.15A max.	
2-color LED display	Servo ON (green), Alarm/motor drive power supply shut-down (red)	
I/O power (Note 1)	common to control power (non-isolated)	
Serial Communication	RS485 1ch (External termination)	
Absolute function	None	
Forced release of electromagnetic brake	Forced release when connected to 0V (NP), or 24V (PN)	Forced release when connected to 24V
Cable Length	I/O cable: 10m max.	
	SIO connector communication cable: 5m or shorter	
Dielectric strength voltage	DC500V 10MΩ	
EMC	EN55011 Class A Group1 (3m)	
Power supply voltage	DC24V ± 10%	
Power supply current	2A max.	
Environment	Ambient operating temperature	0~40°C
	Ambient operating humidity	85% RH or lower (non-condensing)
	Ambient operating atmosphere	Free from corrosive gases
Protection class	IP20	

(Note 1) Use the isolated PIO terminal block (option P604) to isolate the I/O power supply.

PMEC
AMEC

PSEP
ASEP
DSEP

MSEP

ERC3

ERC2

PCON
-CA

PCON

ACON

SCON
-CA

MSCON

PSEL

ASEL

SSEL

XSEL

PS-24

Pulse
Motor

Servo
Motor
(24V)

Servo
Motor
(200V)

Linear
Servo
Motor

- Controller
- PMEC
AMEC
- PSEP
ASEP
DSEP
- MSEP
- ERC3
- ERC2**
- PCON
-CA
- PCON
- ACON
- SCON
-CA
- MSCON
- PSEL
- ASEL
- SSEL
- XSEL
- PS-24
- Pulse Motor
- Servo Motor (24V)
- Servo Motor (200V)
- Linear Servo Motor

I/O Wiring Drawing

PIO Type NP (NPN Specification)

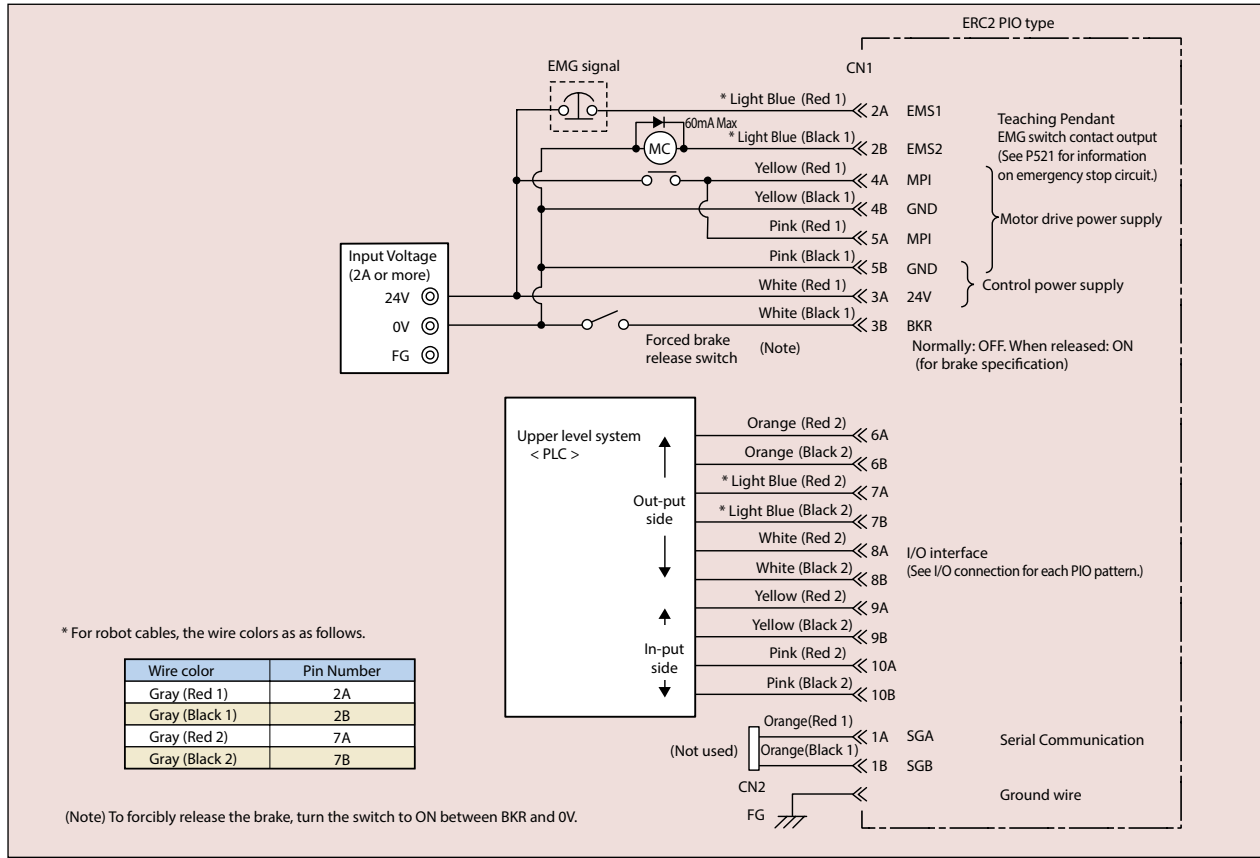

PIO Type PN (PNP Specification)

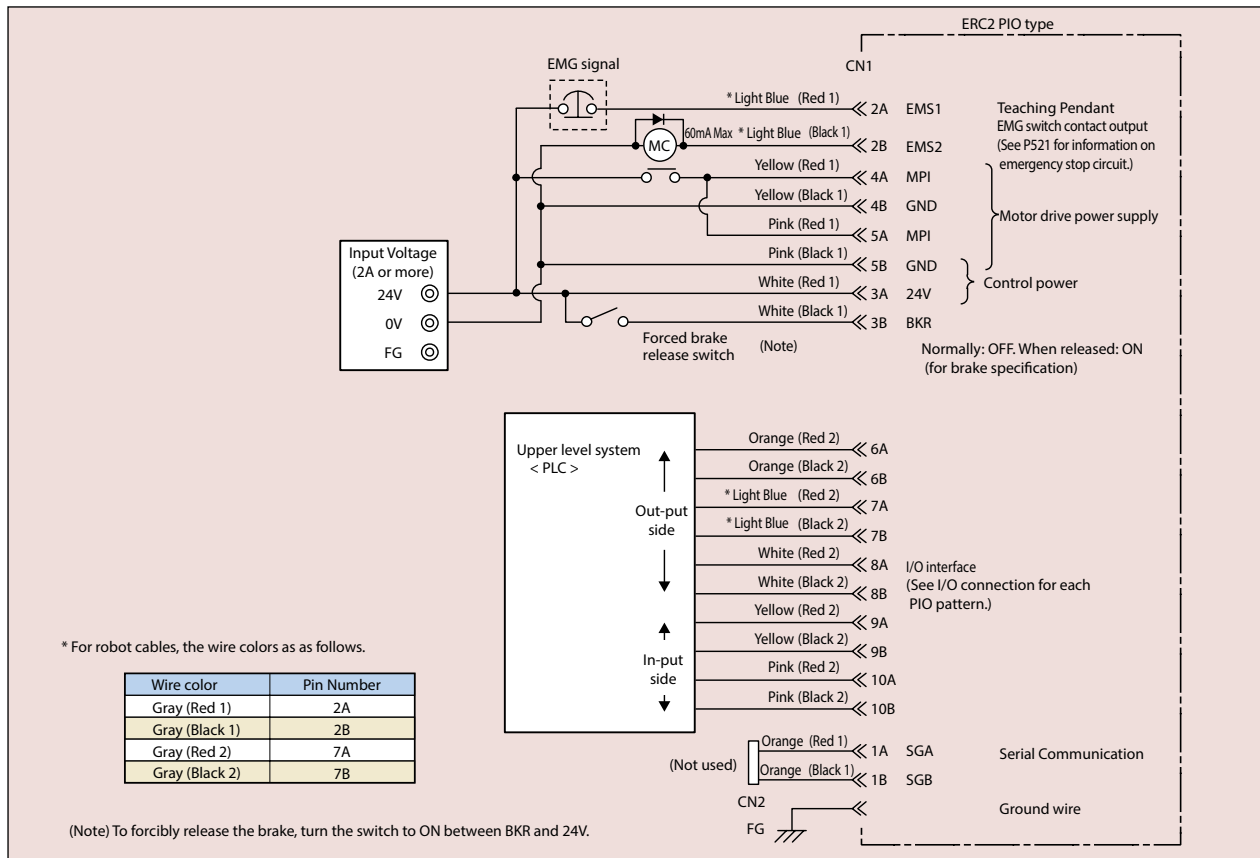

SIO Type SE

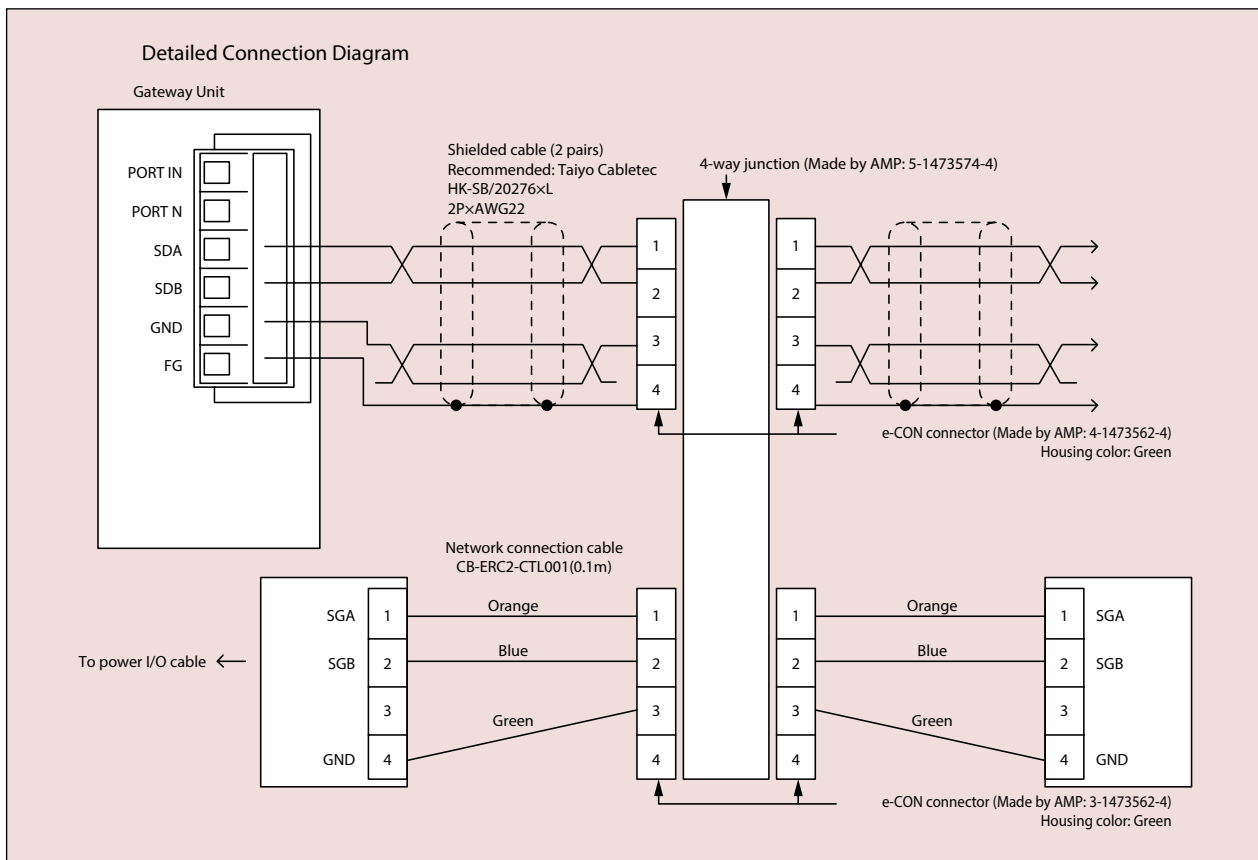
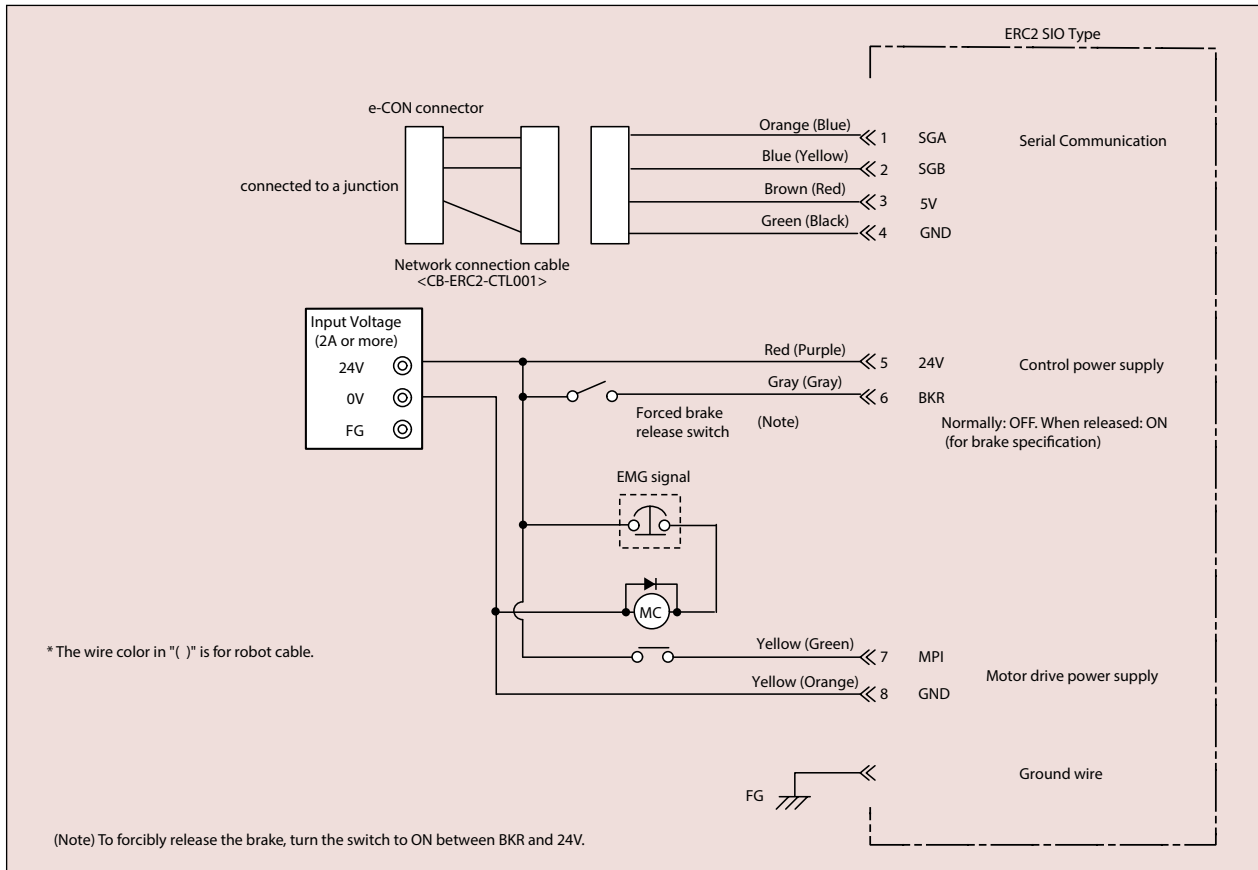

Emergency Stop Circuit

The ERC2 series has no built-in emergency stop circuit, so the customer must provide an emergency stop circuit based on the logic explained below. (The circuit below is simplified for explanation purposes. Provide a ready circuit, etc., according to your specification.)

Single Axis: To provide an emergency stop circuit for a single-axis configuration, operate a relay using the EMS1 and EMS2 contacts of the power & I/O cable to cut off MPI (motor power).

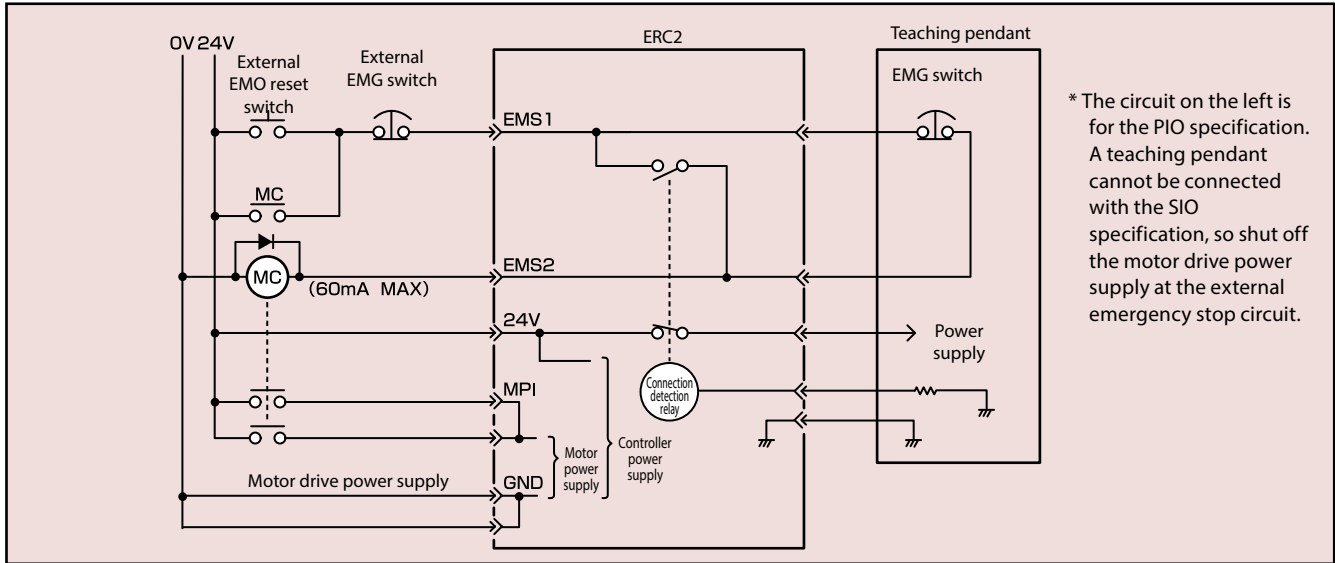

Multiple Axis: To provide an emergency stop circuit for a multiple-axes configuration, operate a relay using the EMG1 and EMG2 contacts of the SIO converter to cut off MPI (motor power) for each axis.

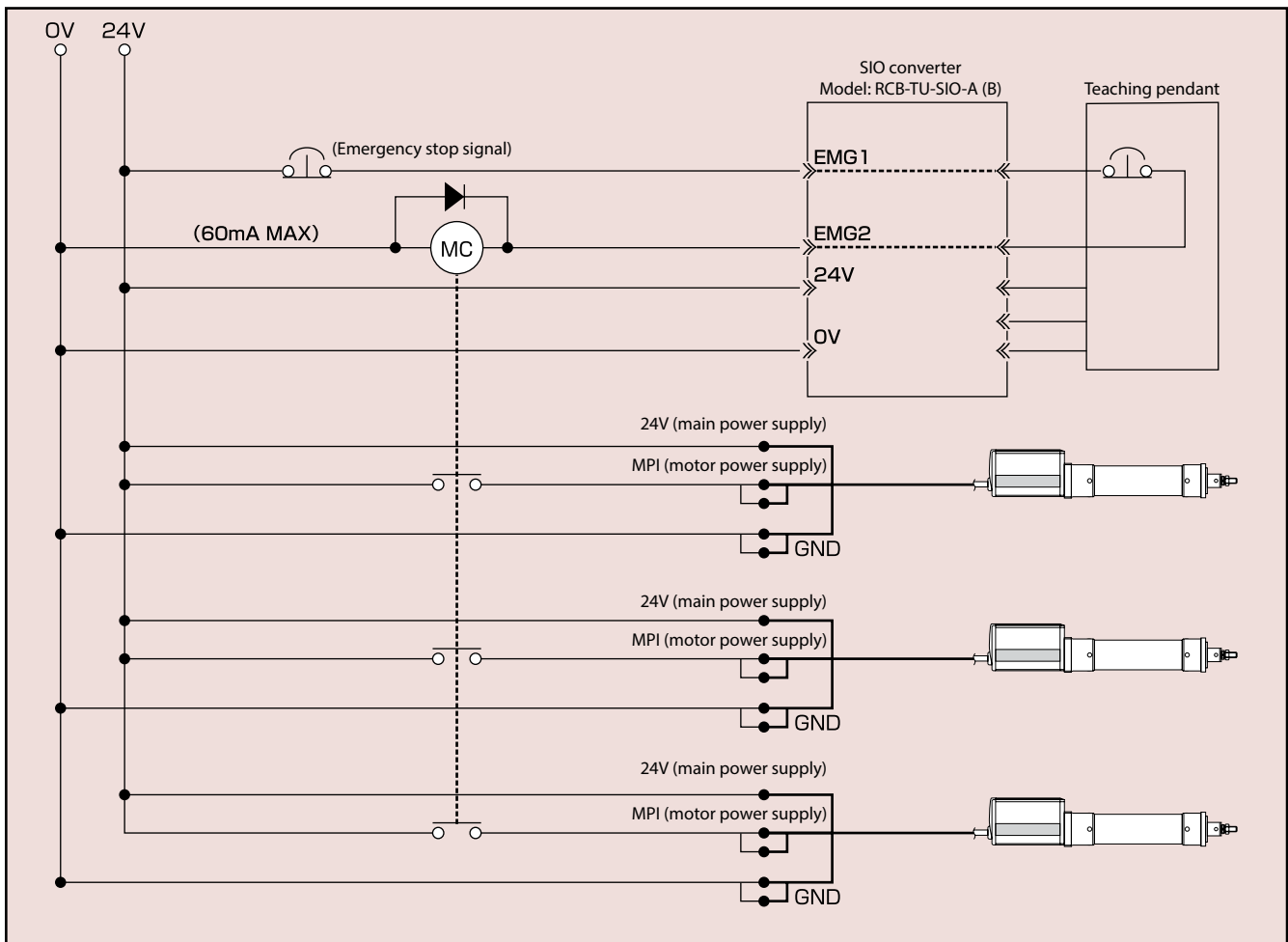

Options

Isolated PIO Terminal Block

This terminal block is used to isolate the I/O power or simplify the wiring with a PLC.

*When a terminal block is used, the optional power & I/O cable with connectors on both ends must be used.

- The input and output ports are non-polar, so both NPN and PNP are compatible with the I/O specifications on the PLC side.
- An input/output-signal monitor LED is equipped to check the ON/OFF status of signals.

Specifications

Item	Specifications	
Power supply voltage	DC24V±10%	
Ambient Operating Temp./Humidity	0 to 55°C, 85%RH or below (non-condensing)	
Input area	Input points	6 points
	Input voltage	DC24V±10%
	Input current	7mA/circuit (bipolar)
	Allowable leaked current	1mA/point (at room temperature, about 2mA)
	Operating voltage (with respect to ground)	Input ON: Min. 16V (4.5mA) OFF: Max. 5V (1.3 mA)
Output area	Output points	4 points
	Rated load voltage	DC24V
	Max. current	60mA/point
	Residual voltage	2V or less/60mA
	Short circuit Overcurrent protection	Fuse resistance (27Ω.1W)

Note:
If you are using the ERC2-PN (PNP specification), use RCB-TU-PIO-AP/BP (compatible with PNP specification).

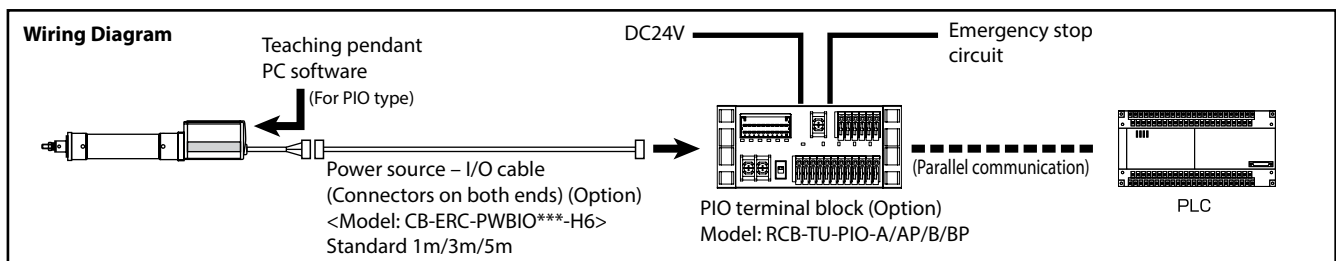
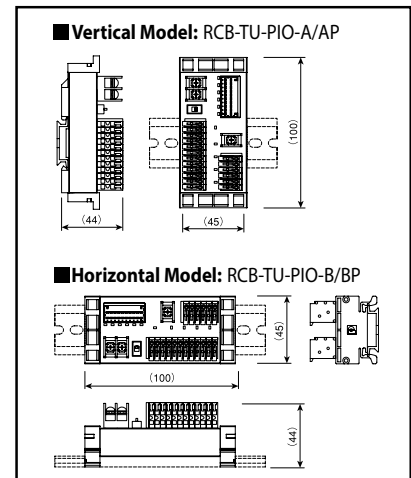

SIO Converter

This converter can be used for RS232 communication by connecting a serial communication wire (SGA, SGB) for the power-I/O cable, and using a D-sub 9-pin cross cable to connect a computer.

- The connection port for teaching-pendant or a PC cable can be installed at any position away from the actuator.
- Multiple axes can be connected and operated from a PC via serial communication.

Specifications

Item	Specifications
Power supply voltage	DC24V ±10%
Ambient Operating Temp./Humidity	0 to 55°C, 85%RH or below (non-condensing)
Terminal resistor	120Ω (built-in)

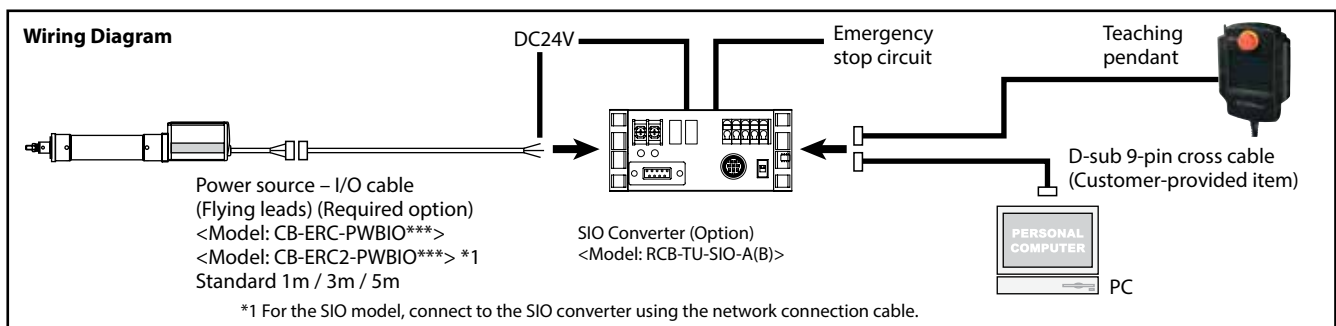
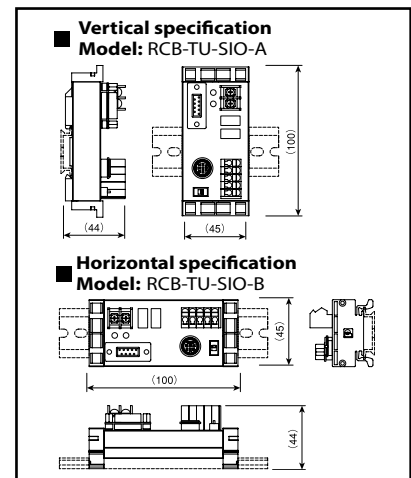

*1 For the SIO model, connect to the SIO converter using the network connection cable.

Options

Teaching Pendant

- Features** This is a teaching device that provides information on functions such as position input, test runs, and monitoring.
- Model** **CON-PTA-C-ENG** (Touch panel teaching pendant)
CON-T-ENG (Standard type)
- Configuration**

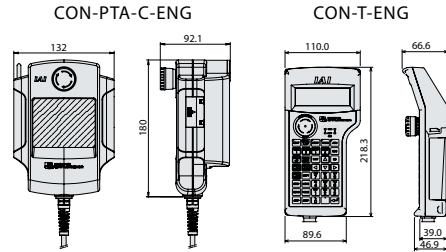

- CON-T-ENG Options**
 - Wall-mounting hook Model **HK-1**
 - Strap Model **STR-1**

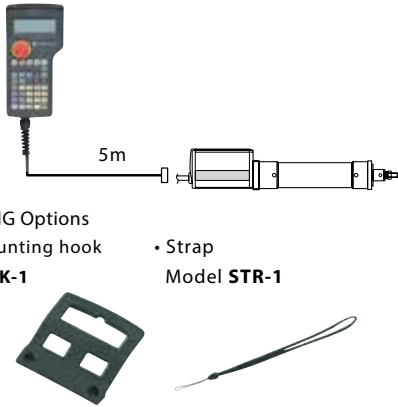

Specification

Item	Content	
Model number	CON-PTA-C-ENG	CON-T-ENG
Data Input	○	○
Actuator Motion	○	○
Ambient Operating Temp./Humidity	Temp 0~40°C; 85% RH or below	
Ambient Operating Atmosphere	No corrosive gases. Especially no dust.	
Protective class	IP40	IP54
Weight	Approx. 570g	Approx. 400g
Cable Length	5m	
Display	65,536 color (16 bit color) White LED back light	20 char. x 4 lines LCD display
Standard Price	—	—

PC Software (Windows Only)

- Features** A startup support software for teaching positions, performing test runs, and monitoring. With enhancements for adjustment functions, the startup time is shortened.
- Model** **RCM-101-MW** (External device communications cable + RS232 conversion unit)

Supported Windows OS:
2000 SP4 or later / XP SP2 or later / Vista / 7

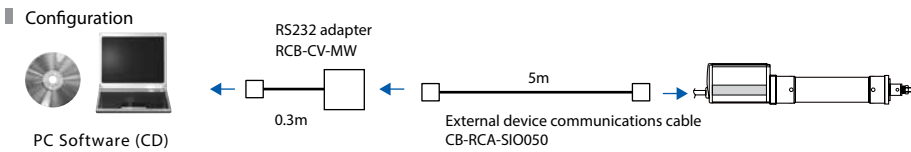

- Model** **RCM-101-USB** (External device communications cable + USB adapter + USB cable)

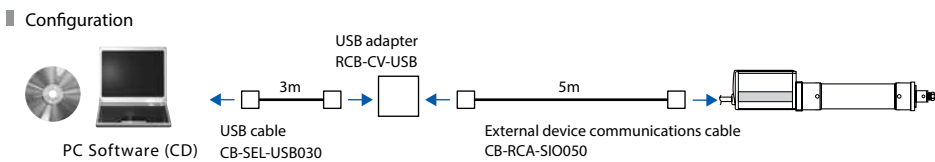

Cables & Spare Parts

Power & I/O Cable, Power & I/O Robot Cable For PIO

Model **CB-ERC-PWBIO** / **CB-ERC-PWBIO**-RB

*Enter the cable length (L) into . Compatible to a maximum of 10 meters. Ex.:080 = 8m

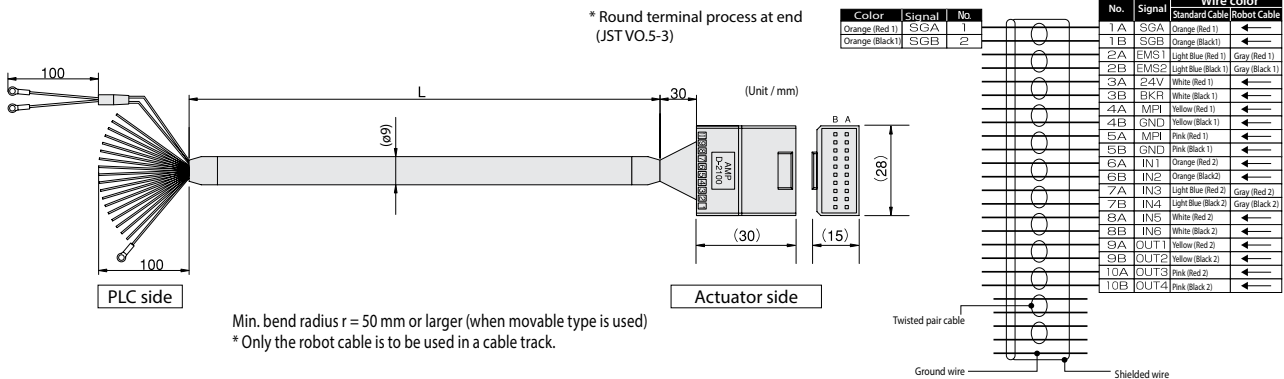

Min. bend radius r = 50 mm or larger (when movable type is used)
* Only the robot cable is to be used in a cable track.

Power & I/O Cable, Power-I/O Robot Cable (Connectors on Both Ends)

Model **CB-ERC-PWBIO**-H6 / **CB-ERC-PWBIO**-RB-H6

*Enter the cable length (L) into . Compatible to a maximum of 10 meters. Ex.:080 = 8m

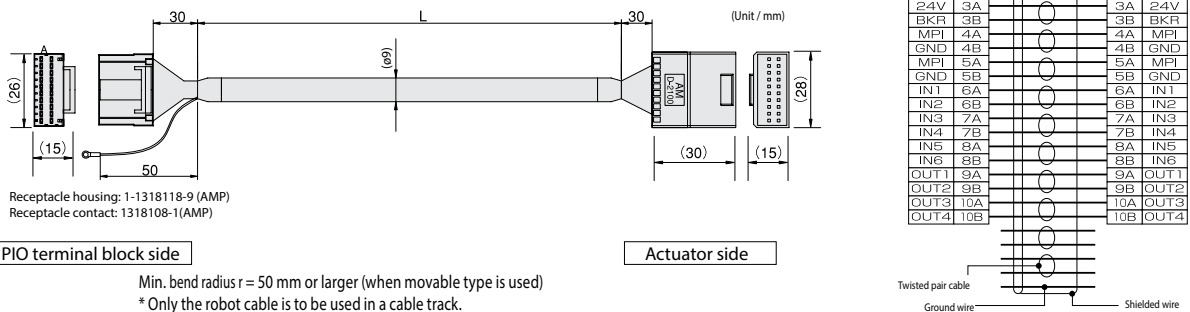

Receptacle housing: 1-1318118-9 (AMP)
Receptacle contact: 1318108-1(AMP)

Min. bend radius r = 50 mm or larger (when movable type is used)
* Only the robot cable is to be used in a cable track.

Power & I/O Cable, Power & I/O Robot Cable For SIO Type

Model **CB-ERC2-PWBIO** / **CB-ERC2-PWBIO**-RB

*Enter the cable length (L) into . Compatible to a maximum of 10 meters. Ex.:080 = 8m

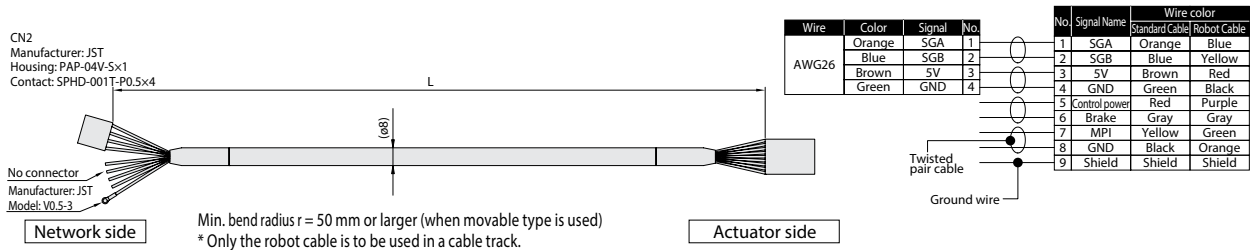

CN2
Manufacturer: JST
Housing: PAP-04V-Sx1
Contact: SPHD-001T-P0.5x4

No connector
Manufacturer: JST
Model: VO.5-3

Min. bend radius r = 50 mm or larger (when movable type is used)
* Only the robot cable is to be used in a cable track.

Network Connection Cable

Model **CB-ERC2-CTL001**

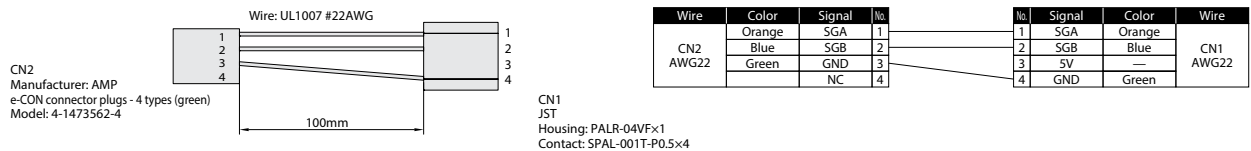

CN2
Manufacturer: AMP
e-CON connector plugs - 4 types (green)
Model: 4-1473562-4

CN1
JST
Housing: PALR-04VFx1
Contact: SPAL-001T-P0.5x4

Communication Cable to Connect to PC

Model **CB-ERC2-SIO020**

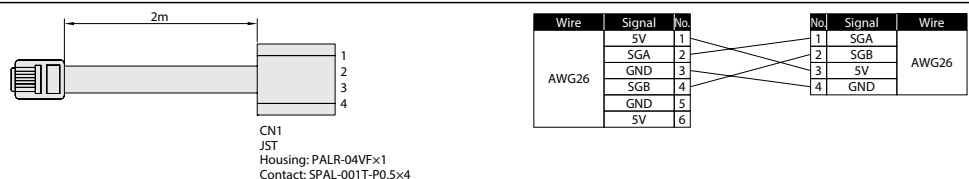

CN2
Japan Chain Terminal (JCT)
Modular plug: NTC-66R

CN1
JST
Housing: PALR-04VFx1
Contact: SPAL-001T-P0.5x4

- Controller
- PMEC
AMEC
- PSEP
ASEP
DSEP
- MSEP
- ERC3
- ERC2
- PCON
-CA
- PCON
- ACON
- SCON
-CA
- MSCON
- PSEL
- ASEL
- SSEL
- XSEL
- PS-24
- Pulse
Motor
- Servo
Motor
(24V)
- Servo
Motor
(200V)
- Linear
Servo
Motor

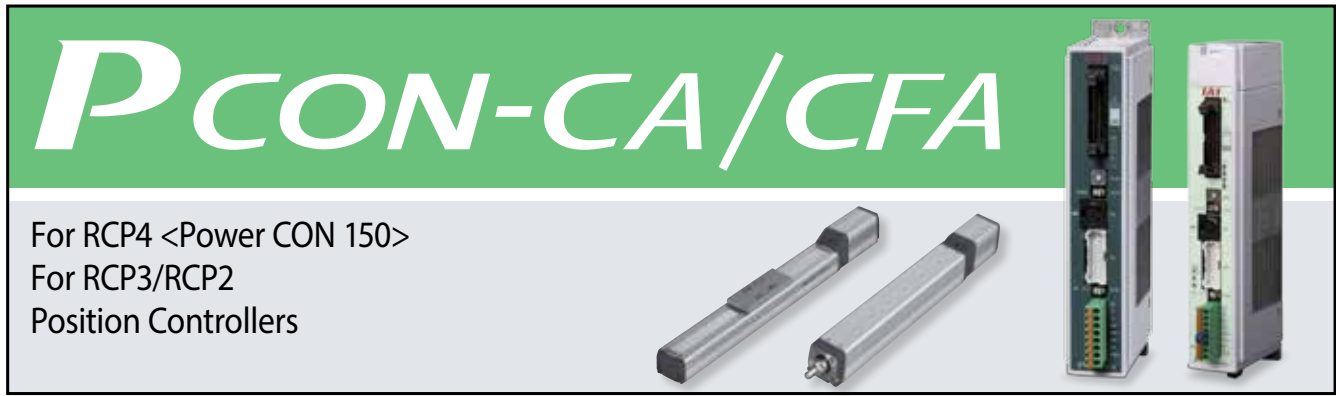

For RCP4 <Power CON 150>
For RCP3/RCP2
Position Controllers

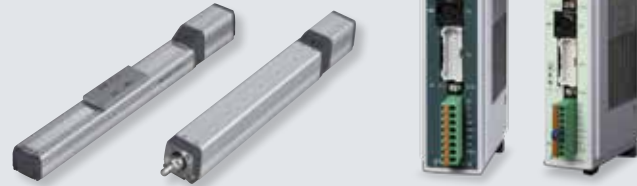

Features

1 Built-in high-output driver designed exclusively for RCP4 generates greater torque at high speed

The newly developed high-output driver (patent pending) achieves significantly improved specifications compared to conventional models (RCP2 series), with the acceleration/deceleration higher by 1.4 times, maximum speed by 1.5 times, and payload twice as large.
(* The rates of improvement vary depending on the type.
(* RCP3/RCP2 also can be operated.

Acceleration/ deceleration	RCP2	0.7G	1.4 times
	RCP4	1.0G	
Maximum speed	RCP2	1000mm/s	1.5 times
	RCP4	1440mm/s	
Payload	RCP2	6kg	2 times
	RCP4	12kg	

2 DeviceNet, CC-Link, PROFIBUS-DP, CompoNet, MECHATROLINK (I, II), EtherCAT, EtherNet/IP are supported

Features include wire-saving design, as well as the abilities to support direct numerical specification, position number specification, current position read, etc.

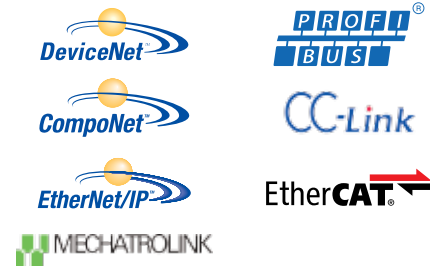

3 Incremental specification and simple absolute specification to choose from

You can choose one of the two types: the incremental specification and the simple absolute specification. The simple absolute specification is available in three types, including the specification having only the absolute battery attached on the side face of the actuator, specification equipped with the absolute battery unit where screw stopper/DIN rail mounting is possible, and controller-only specification without absolute battery.

(Note) All pulse-train Power CON controllers are of the incremental specification.

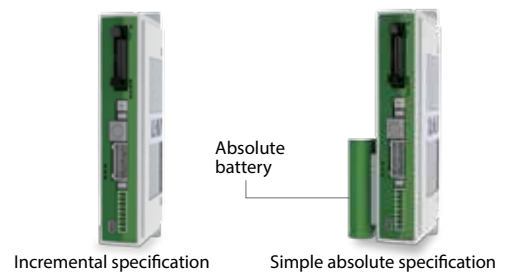

4 Smart tuning function, maintenance information, calendar function

The takt time minimization function sets an optimal acceleration/deceleration rate according to the load that is available (*). You can also record the number of times the actuator has moved and the distance that it has travelled, for use in maintenance.



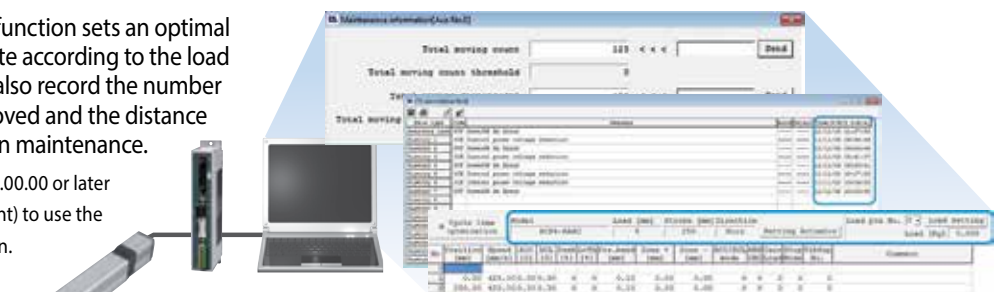





(* You need PC software Ver. 8.03.00.00 or later or a CON-PTA (teaching pendant) to use the takt time minimization function.











607 PCON-CA /CFA

List of Models

ROBO Cylinder Position Controller PowerCON 150 <PCON-CA>

External view										
I/O type		Positioner type	Pulse-train type	Field network type						
										
				DeviceNet connection specification	CC-Link connection specification	PROFIBUS-DP connection specification	CompoNet connection specification	MECHATROLINK connection specification	EtherCAT connection specification	EtherNet/IP connection specification
I/O type model code		NP/PN	PLN/PLP	DV	CC	PR	CN	ML	EC	EP
Standard price	Incremental specification	—	—	—	—	—	—	—	—	—
	Simple absolute specification	With absolute battery	—	—	—	—	—	—	—	—
		No absolute battery	—	—	—	—	—	—	—	—

ROBO Cylinder Position Controller High-thrust Motor Type <PCON-CFA>

External view										
I/O type		Positioner type	Pulse-train type	Field network type						
										
				DeviceNet connection specification	CC-Link connection specification	PROFIBUS-DP connection specification	CompoNet connection specification	MECHATROLINK connection specification	EtherCAT connection specification	EtherNet/IP connection specification
I/O type model code		NP/PN	PLN/PLP	DV	CC	PR	CN	ML	EC	EP
Standard price	Incremental specification	—	—	—	—	—	—	—	—	—

- Controller
- PMEC
AMEC
- PSEP
ASEP
DSEP
- MSEP
- ERC3
- ERC2
- PCON
-CA
- PCON
- ACON
- SCON
-CA
- MSCON
- PSEL
- ASEL
- SSEL
- XSEL
- PS-24
- Pulse Motor
- Servo Motor (24V)
- Servo Motor (200V)
- Linear Servo Motor

Model Number

<Controller>

PCON — **CA** — [] — **I** — [] — [] — **0** — [] — []

Series Type Motor type Encode type I/O type I/O cable length Power supply voltage Simple absolute specification Actuator mounting specification

CA Standard type

20P	20 frame pulse motor
20SP	20 frame pulse motor (RCP3-RA2 high-thrust type dedicated)
28P	28 frame pulse motor
28SP	28 frame pulse motor (RCP2-RA3C dedicated)
35P	35 frame pulse motor
42P	42 frame pulse motor
56P	56 frame pulse motor

I Incremental

NP	PIO (NPN) specification
PLN	Pulse-train (NPN) specification
PN	PIO (PNP) specification
PLP	Pulse-train (PNP) specification
DV	DeviceNet connection specification
CC	CC-Link connection specification
PR	PROFIBUS-DP connection specification
CN	CompoNet connection specification
ML	MECHATROLINK connection specification
EC	EtherCAT connection specification
EP	EtherNet/IP connection specification

0	No cable
2	2 m
3	3 m
5	5 m

* If a network connection specification (I/O type = DV, CC, PR, CN, ML, EC or EP) is selected, the I/O cable length becomes "0" (no cable).

0	DC24V
---	-------

(Blank)	Incremental specification
AB	Simple absolute specification (With absolute battery)
ABU	Simple absolute specification (With absolute battery unit)
ABUN	Simple absolute specification (No absolute battery)

(Blank)	Screw fastening specification
DN	DIN rail mounting specification

* The mounting specification for the absolute battery unit (screws mounting or DIN rail mounting) conforms to the mounting specification for the controller.

<Controller>

PCON — **CFA** — [] — **I** — [] — [] — **0** — [] — []

Series Type Motor type Encode type I/O type I/O cable length Power supply voltage Actuator mounting specification

CFA High-thrust motor type

60P	60 frame pulse motor
86P	86 frame pulse motor

I Incremental

NP	PIO (NPN) specification
PLN	Pulse-train (NPN) specification
PN	PIO (PNP) specification
PLP	Pulse-train (PNP) specification
DV	DeviceNet connection specification
CC	CC-Link connection specification
PR	PROFIBUS-DP connection specification
CN	CompoNet connection specification
ML	MECHATROLINK connection specification
EC	EtherCAT connection specification
EP	EtherNet/IP connection specification

0	No cable
2	2 m
3	3 m
5	5 m

* If a network connection specification (I/O type = DV, CC, PR, CN, ML, EC or EP) is selected, the I/O cable length becomes "0" (no cable).

0	DC24V
---	-------

(Blank)	Screw fastening specification
DN	DIN rail mounting specification

* The PCON-CFA does not support the simple absolute specification.

System Configuration

Power CON 150 <PCON-CA>

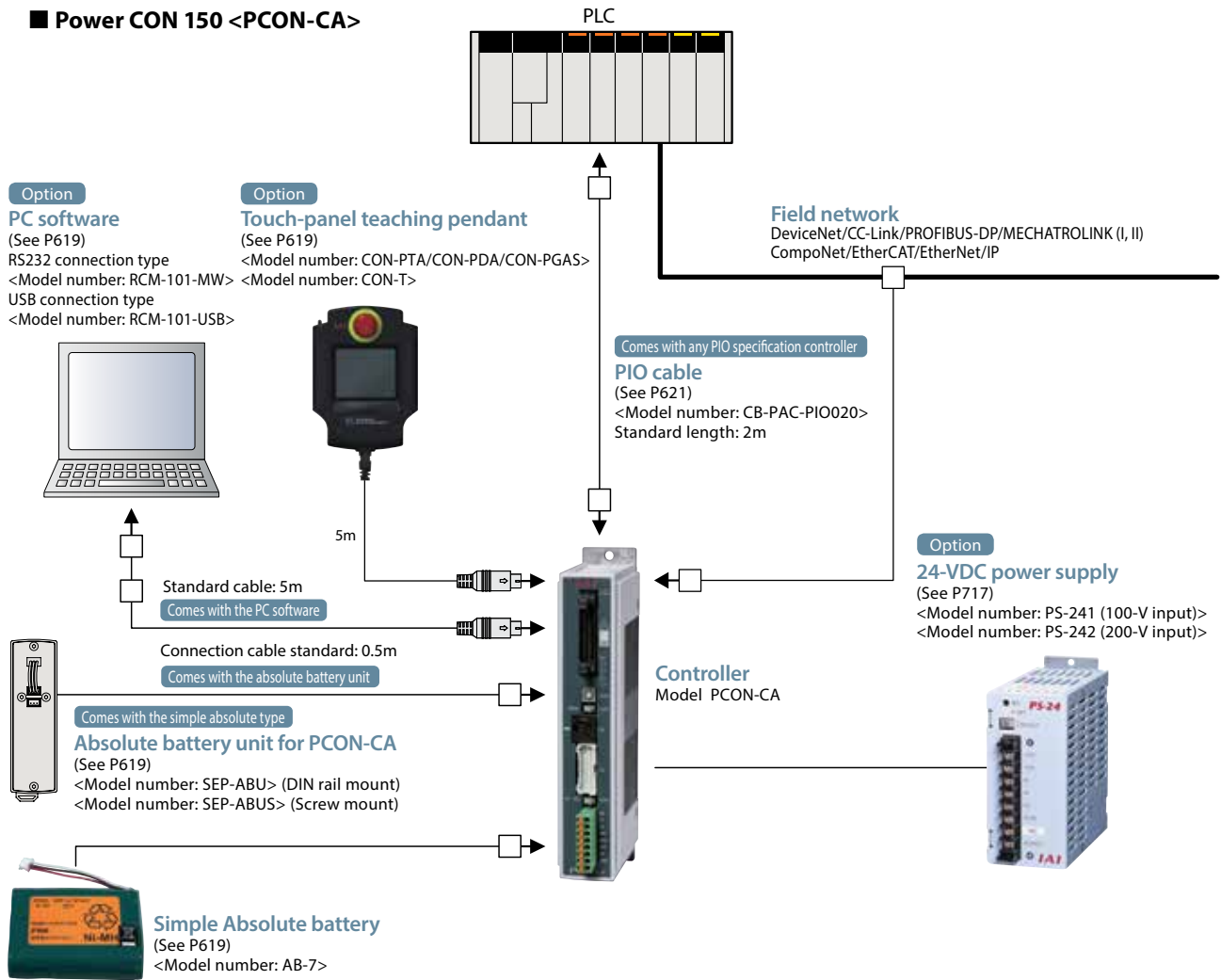

< Connectable actuators >

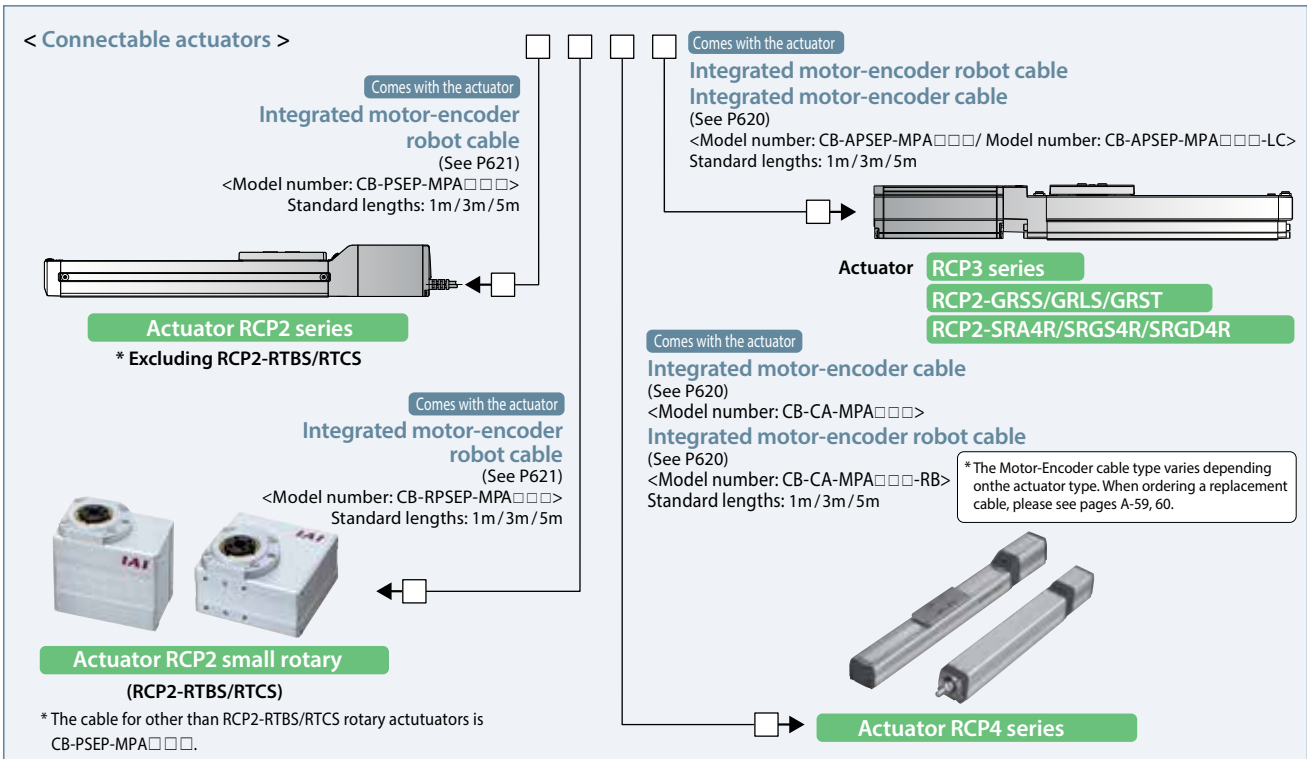

PMEC
AMEC

PSEP
ASEP
DSEP

MSEP

ERC3

ERC2

PCON
-CA

PCON

ACON

SCON
-CA

MSCON

PSEL

ASEL

SSEL

XSEL

PS-24

Pulse
Motor

Servo
Motor
(24V)

Servo
Motor
(200V)

Linear
Servo
Motor

- Controller
- PMEC
AMEC
- PSEP
ASEP
DSEP
- MSEP
- ERC3
- ERC2
- PCON
-CA
- PCON
- ACON
- SCON
-CA
- MSCON
- PSEL
- ASEL
- SSEL
- XSEL
- PS-24
- Pulse
Motor
- Servo
Motor
(24V)
- Servo
Motor
(200V)
- Linear
Servo
Motor

System Configuration

High-thrust Motor Type <PCON-CFA>

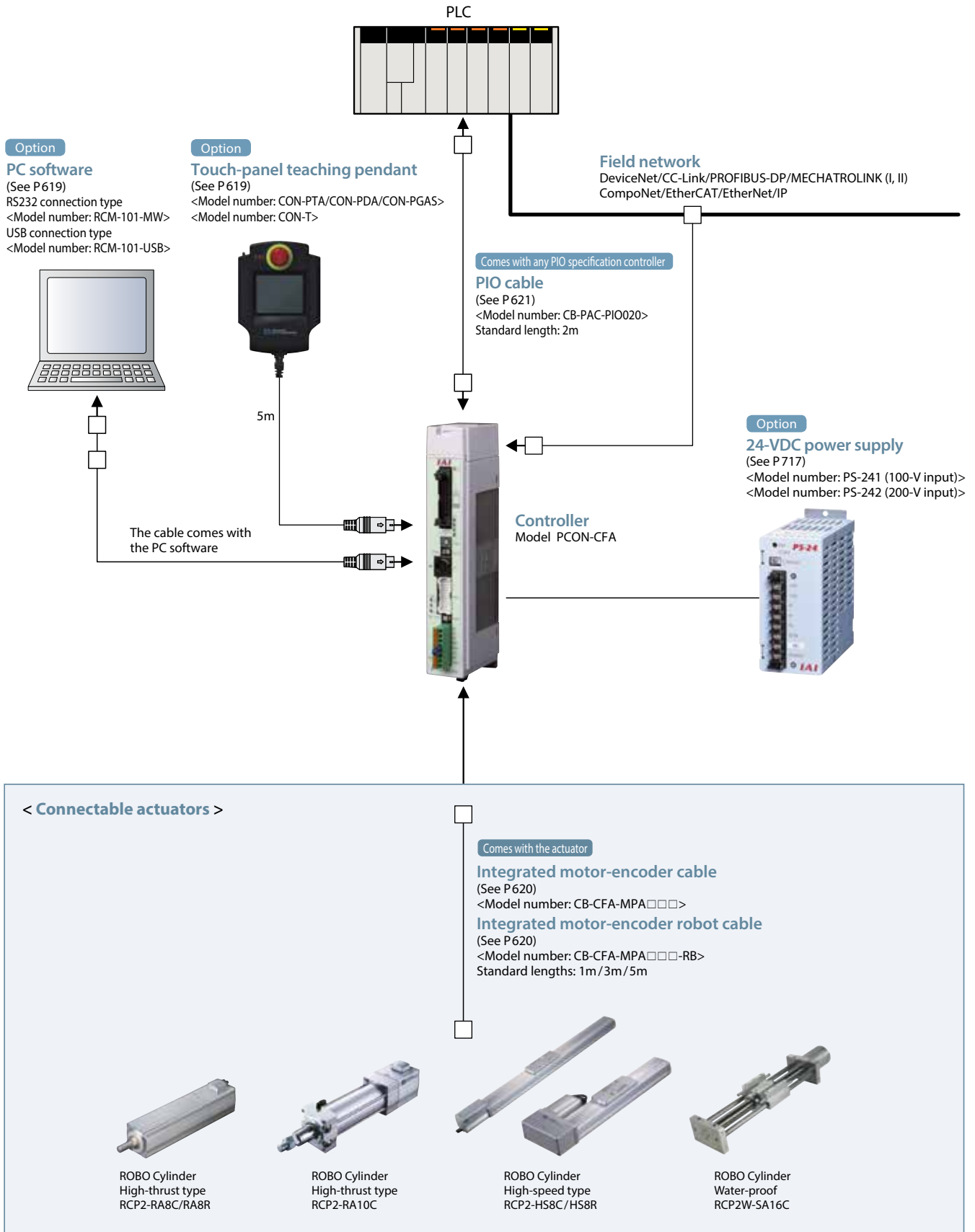

PIO I/O Interface

Input Part External Input Specifications

Item	Specification
Input voltage	24 VDC ± 10%
Input current	5mA, 1 circuit
ON/OFF voltage	ON voltage: 18 VDC min. OFF voltage: 6 VDC max.

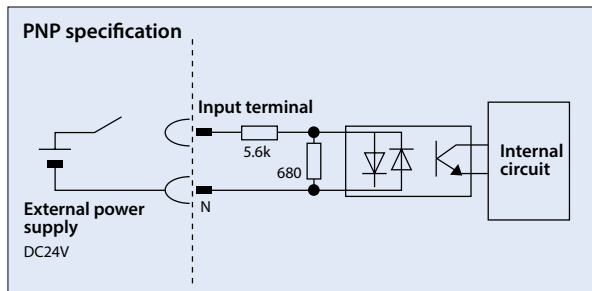
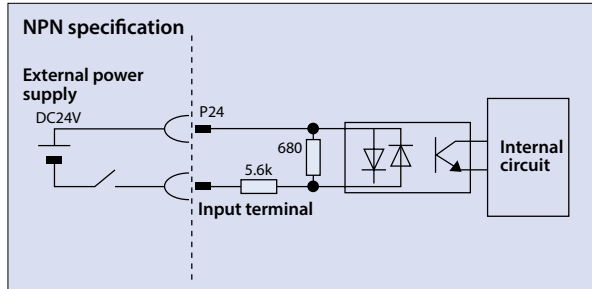

Output Part External Output Specifications

Item	Specification
Load voltage	24 VDC
Maximum load current	50mA, 1 circuit
Leak current	2mA max. per point

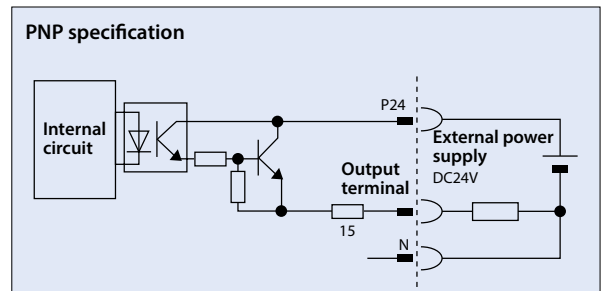
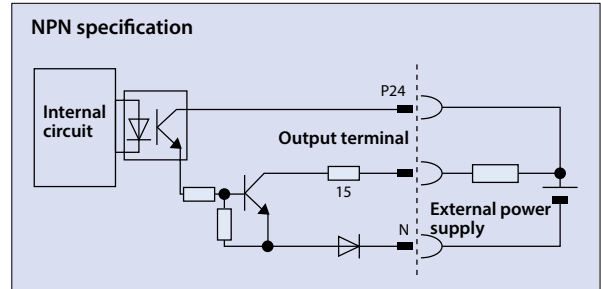

Types of PIO Patterns (Control Patterns)

This controller supports seven types of control methods. Select in Parameter No. 25, "PIO pattern selection" the PIO pattern that best suits your purpose of use.

Type	Set value of Parameter No. 25	Mode	Overview
PIO pattern 0	0 (factory setting)	Positioning mode (standard type)	<ul style="list-style-type: none"> Number of positioning points: 64 points Position number command: Binary Coded Decimal (BCD) Zone signal output*1: 1 point Position zone signal output*2: 1 point
PIO pattern 1	1	Teaching mode (teaching type)	<ul style="list-style-type: none"> Number of positioning points: 64 points Position number command: Binary Coded Decimal (BCD) Position zone signal output*2: 1 point Jog (inching) operation using PIO signals is supported. Current position data can be written to the position table using PIO signals.
PIO pattern 2	2	256-point mode (256 positioning points)	<ul style="list-style-type: none"> Number of positioning points: 256 points Position number command: Binary Coded Decimal (BCD) Position zone signal output*2: 1 point
PIO pattern 3	3	512-point mode (512 positioning points)	<ul style="list-style-type: none"> Number of positioning points: 512 points Position number command: Binary Coded Decimal (BCD) No zone signal output
PIO pattern 4	4	Solenoid valve mode 1 (7-point type)	<ul style="list-style-type: none"> Number of positioning points: 7 points Position number command: Individual number signal ON Zone signal output*1: 1 point Position zone signal output*2: 1 point
PIO pattern 5	5	Solenoid valve mode 2 (3-point type)	<ul style="list-style-type: none"> Number of positioning points: 3 points Position number command: Individual number signal ON Completion signal: A signal equivalent to a LS (limit switch) signal can be output. Zone signal output*1: 1 point Position zone signal output*2: 1 point
PIO pattern 6 (Note)	6	Pulse-train control mode	<ul style="list-style-type: none"> Differential pulse input (200 kpps max.) Home return function Zone signal output*1: 2 points No feedback pulse output

*1 Zone signal output: A desired zone is set by Parameter Nos. 1 and 2 or 23 and 24, and the set zone always remains effective once home return has completed.

*2 Position zone signal output: This function is available as part of a position number. A desired zone is set in the position table and becomes effective only when the corresponding position is specified, but not with commands specifying other positions.

(Note) Pulse Train Control Model is available only if the pulse train control type is indicated (PCON-CA-PLN or PLP) at the time of purchase.

- Controller
- PMEC
AMEC
- PSEP
ASEP
DSEP
- MSEP
- ERC3
- ERC2
- PCON
-CA
- PCON
- ACON
- SCON
-CA
- MSCON
- PSEL
- ASEL
- SSEL
- XSEL
- PS-24
- Pulse Motor
- Servo Motor (24V)
- Servo Motor (200V)
- Linear Servo Motor

PIO Patterns and Signal Assignments

The table below lists the signal assignments for the I/O flat cable under different PIO patterns. Connect an external device (such as a PLC) according to this table.

Pin number	Category	PIO function	Parameter No. 25, "PIO pattern selection"					
			0	1	2	3	4	5
			Positioning mode	Teaching mode	256-point mode	512-point mode	Solenoid valve mode 1	Solenoid valve mode 2
		Number of positioning points	64 points	64 points	256 points	512 points	7 points	3 points
	Input	Home return signal	○	○	○	○	○	×
		Jog signal	×	○	×	×	×	×
		Teaching signal (writing of current position)	×	○	×	×	×	×
		Brake release	○	×	○	○	○	○
		Output	Moving signal	○	○ (Note 1)	×	×	×
	Zone signal		○	△	△	×	○	○
	Position zone signal		○	○	○	×	○	○
1A	24V	P24						
2A	24V	P24						
3A	Pulse input	—						
4A		—						
5A	Input	IN0	PC1	PC1	PC1	PC1	ST0	ST0
6A		IN1	PC2	PC2	PC2	PC2	ST1	ST1(JOG+)
7A		IN2	PC4	PC4	PC4	PC4	ST2	ST2(-)
8A		IN3	PC8	PC8	PC8	PC8	ST3	—
9A		IN4	PC16	PC16	PC16	PC16	ST4	—
10A		IN5	PC32	PC32	PC32	PC32	ST5	—
11A		IN6	—	MODE	PC64	PC64	ST6	—
12A		IN7	—	JISL	PC128	PC128	—	—
13A		IN8	—	JOG+	—	PC256	—	—
14A		IN9	BKRL	JOG-	BKRL	BKRL	BKRL	BKRL
15A		IN10	RMOD	RMOD	RMOD	RMOD	RMOD	RMOD
16A		IN11	HOME	HOME	HOME	HOME	HOME	—
17A		IN12	*STP	*STP	*STP	*STP	*STP	—
18A		IN13	CSTR	CSTR/PWRT	CSTR	CSTR	—	—
19A		IN14	RES	RES	RES	RES	RES	RES
20A	IN15	SON	SON	SON	SON	SON	SON	
1B	Output	OUT0	PM1(ALM1)	PM1(ALM1)	PM1(ALM1)	PM1(ALM1)	PE0	LSO
2B		OUT1	PM2(ALM2)	PM2(ALM2)	PM2(ALM2)	PM2(ALM2)	PE1	LS1(TRQS)
3B		OUT2	PM4(ALM4)	PM4(ALM4)	PM4(ALM4)	PM4(ALM4)	PE2	LS2
4B		OUT3	PM8(ALM8)	PM8(ALM8)	PM8(ALM8)	PM8(ALM8)	PE3	—
5B		OUT4	PM16	PM16	PM16	PM16	PE4	—
6B		OUT5	PM32	PM32	PM32	PM32	PE5	—
7B		OUT6	MOVE	MOVE	PM64	PM64	PE6	—
8B		OUT7	ZONE1	MODES	PM128	PM128	ZONE1	ZONE1
9B		OUT8	PZONE/ZONE2	PZONE/ZONE1	PZONE/ZONE1	PM256	PZONE/ZONE2	PZONE/ZONE2
10B		OUT9	RMDS	RMDS	RMDS	RMDS	RMDS	RMDS
11B		OUT10	HEND	HEND	HEND	HEND	HEND	HEND
12B		OUT11	PEND	PEND/WEND	PEND	PEND	PEND	—
13B		OUT12	SV	SV	SV	SV	SV	SV
14B		OUT13	*EMGS	*EMGS	*EMGS	*EMGS	*EMGS	*EMGS
15B		OUT14	*ALM	*ALM	*ALM	*ALM	*ALM	*ALM
16B	OUT15	LOAD/TRQS *ALML	*ALML	LOAD/TRQS *ALML	LOAD/TRQS *ALML	LOAD/TRQS *ALML	*ALML	
17B	Pulse input	—						
18B		—						
19B	0V	N						
20B	0V	N						

(Note) In the table above, asterisk * symbol accompanying each code indicates a negative logic signal. PM1 to PM8 are alarm binary code output signals that are used when an alarm generates.
 (Note 1) In all PIO patterns other than 3, this signal can be switched with PZONE by setting Parameter No. 149 accordingly.
 (Note 2) The setting will not become effective until the origin return is completed.
Reference) Negative logic signal
 Signals denoted by * are negative logic signals. Negative logic input signals are processed when turned OFF. Negative logic output signals normally remain ON while the power is supplied, and turn OFF when the signal is output.
 Note: The names of the signals above inside () are functions before the unit returns home.

Pulse-train Control Circuit

■ Host Unit = Differential Type

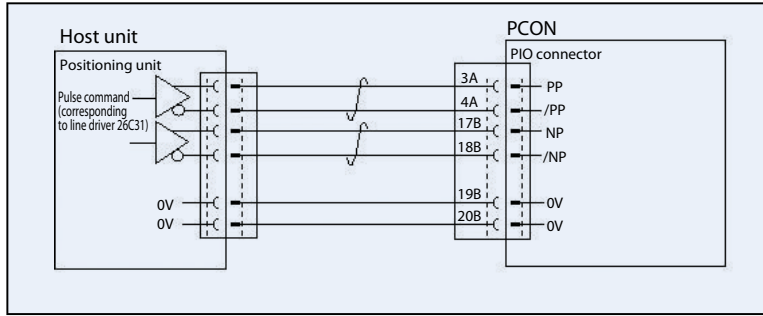

■ Host Unit = Open Collector Type

The AK-04 (optional) is needed to input pulses.

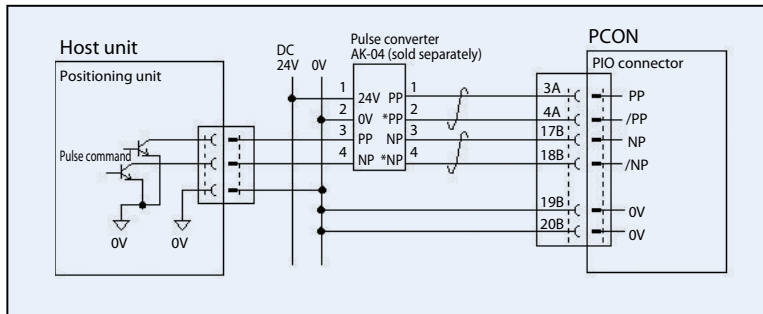

Caution: Use the same power supply for open collector input/output to/from the host and for the AK-04.

Command Pulse Input Patterns

	Command pulse-train pattern	Input terminal	Forward	Reverse	
Negative logic	Forward pulse-train	PP-/PP			
	Reverse pulse-train	NP-/NP			
	A forward pulse-train indicates the amount of motor rotation in the forward direction, while a reverse pulse-train indicates the amount of motor rotation in the reverse direction.				
	Pulse-train	PP-/PP			
	Sign	NP-/NP	Low	High	
	The command pulses indicate the amount of motor rotation, while the sign indicates the rotating direction.				
	Phase A/B pulse-train	PP-/PP NP-/NP			
Command phases A and B having a 90° phase difference (multiplier is 4) indicate the amount of rotation and the rotating direction.					
Positive logic	Forward pulse train	PP-/PP			
	Reverse pulse-train	NP-/NP			
	Pulse-train	PP-/PP			
	Sign	NP-/NP	High	Low	
	Phase A/B pulse-train	PP-/PP NP-/NP			

- Controller
- PMEC
AMEC
- PSEP
ASEP
DSEP
- MSEP
- ERC3
- ERC2
- PCON
-CA**
- PCON
- ACON
- SCON
-CA
- MCON
- PSEL
- ASEL
- SSEL
- XSEL
- PS-24
- Pulse
Motor
- Servo
Motor
(24V)
- Servo
Motor
(200V)
- Linear
Servo
Motor

I/O Signals in Pulse-train Control Mode

The table below lists the signal assignments for the flat cable in the pulse-train control mode. Connect an external device (such as PLC) according to this table.

Pin number	Category	I/O number	Signal abbreviation	Signal name	Parameter No. 25, "PIO pattern 6"
1A	24V		P24	Power supply	I/O power supply +24 V
2A	24V		P24	Power supply	I/O power supply +24 V
3A	Pulse input		PP	Differential pulse-train input (+)	Differential pulses are input from the host. Up to 200 kpps can be input.
4A			/PP	Differential pulse-train input (-)	
5A	Input	IN0	SON	Servo ON	The servo is ON while this signal is ON, and OFF while the signal is OFF.
6A		IN1	RES	Reset	Present alarms are reset when this signal is turned ON.
7A		IN2	HOME	Home return	Home return operation is performed when this signal is turned ON.
8A		IN3	TL	Torque limit selection	When this signal is turned ON, the motor torque is limited to the value set by the parameter.
9A		IN4	CSTP	Forced stop	The actuator is forcibly stopped when this signal has remained ON for 16 ms or more. The actuator decelerates to a stop at the torque set in the controller and the servo turns OFF.
10A		IN5	DCLR	Deviation counter clear	This signal clears the deviation counter.
11A		IN6	BKRL	Forced brake release	The brake is forcibly released.
12A		IN7	RMOD	Operation mode switching	The operation mode can be switched when the MODE switch on the controller is set to AUTO. (AUTO when this signal is OFF, and to MANU when the signal is ON.)
13A		IN8	NC	—	Not used
14A		IN9	NC	—	Not used
15A		IN10	NC	—	Not used
16A		IN11	NC	—	Not used
17A		IN12	NC	—	Not used
18A		IN13	NC	—	Not used
19A		IN14	NC	—	Not used
20A	IN15	NC	—	Not used	
1B	Output	OUT0	PWR	System ready	This signal turns ON when the controller becomes ready after the main power has been turned on.
2B		OUT1	SV	Servo ON status	This signal turns ON when the servo is ON.
3B		OUT2	INP	Positioning complete	This signal turns ON when the amount of remaining travel pulses in the deviation counter falls within the in-position band.
4B		OUT3	HEND	Home return complete	This signal turns ON upon completion of home return.
5B		OUT4	TLR	Torque limited	This signal turns ON upon reaching the torque limit while the torque is limited.
6B		OUT5	*ALM	Controller alarm status	This signal turns ON when the controller is normal, and turns OFF when an alarm generates.
7B		OUT6	*EMGS	Emergency stop status	This signal turns ON when the emergency stop of the controller is cancelled, and turns OFF when an emergency stop is actuated.
8B		OUT7	RMDS	Operation mode status	The operation mode status is output. This signal turns ON when the controller is in the manual mode.
9B		OUT8	ALM1	Alarm code output signal	An alarm code is output when an alarm generates. For details, refer to the operation manual.
10B		OUT9	ALM2		
11B		OUT10	ALM4		
12B		OUT11	ALM8		
13B		OUT12	*ALML	Minor failure alarm	This signal is output when a message-level alarm generates.
14B		OUT13	NC	—	Not used
15B		OUT14	ZONE1	Zone signal 1	This signal turns ON when the current position of the actuator falls within the parameter-set range.
16B	OUT15	ZONE2	Zone signal 2		
17B	Pulse input		NP	Differential pulse-train input (+)	Differential pulses are input from the host. Up to 200 kpps can be input.
18B			/NP	Differential pulse-train input (-)	
19B	0V		N	Power supply	I/O power supply 0 V
20B	0V		N	Power supply	I/O power supply 0 V

Note) * indicates a negative logic signal. Negative logic signals are normally ON while the power is supplied, and turn OFF when the signal is output.

(Note) The number of encoder pulses is 800 with all RCP4, RCP3, RCP2 series models. For details, refer to the operation manual.

Field Network Specification: Explanation of Operation Modes

If the PCON-CA is controlled via a field network, you can select one of the following five modes to operate the actuator. Take note that the required data areas on the PLC side vary depending on the mode.

Explanation of Modes

Mode	Description
0 Remote I/O mode	In this mode, the actuator is operated by controlling the ON/OFF of bits via the network, just like with the PIO specification. The number of positioning points and functions vary with each of the operation patterns (PIO patterns) that can be set by the controller's parameter.
1 Position/simple direct numerical mode	The target position is specified by directly entering a value, while other operating conditions (speed, acceleration, etc.) are set by specifying the desired position number corresponding to the desired operating conditions already input to the position data table.
2 Half direct numerical mode	The actuator is operated by specifying the speed, acceleration/deceleration and push current, in addition to the target position, by directly entering values.
3 Full direct numerical mode	The actuator is operated by specifying the target position, speed, acceleration/deceleration, push current control value, etc., by directly entering values. The current position, current speed, command current, etc., can also be read.
4 Remote I/O mode 2	Same as the above remote I/O mode, plus the current position read function and command current read function.

Required Data Size for Each Network

Mode	DiviceNet	CC-Link	PROFIBUS-DP	CompoNet	MECHATROLINK I, II	EtherCAT	EtherNet/IP
0 Remote I/O mode	1CH	1 station	2 bytes	2 bytes	*	2 bytes	2 bytes
1 Position/simple direct numerical mode	4CH	1 station	8 bytes	8 bytes	*	8 bytes	8 bytes
2 Half direct numerical mode	8CH	2 stations	16 bytes	16 bytes	*	16 bytes	16 bytes
3 Full direct numerical mode	16CH	4 stations	32 bytes	32 bytes	*	32 bytes	32 bytes
4 Remote I/O mode 2	6CH	1 station	12 bytes	12 bytes	*	12 bytes	12 bytes

* No required data size is set for MECHATROLINK I and II.

List of Functions by Operation Mode

	Remote I/O mode	Position/simple direct numerical mode	Half direct numerical mode	Full direct numerical mode (Note 1)	Remote I/O mode 2
Number of positioning points	512 points	768 points	Unlimited	Unlimited	512 points
Operation by direct position data specification	X	○	○	○	X
Direct speed/acceleration specification	X	X	○	○	X
Push-motion operation	○	○	○	○	○
Current position read	X	○	○	○	○
Current speed read	X	X	○	○	X
Operation by position number specification	○	○	X	X	○
Completed position number read	○	○	X	X	○

* O indicates that the operation is supported, and X indicates that it is not supported. (Note 1) Take note that the MECHATROLINK specification does not support the full direct numerical mode.

External Dimensions

<PCON-CA>

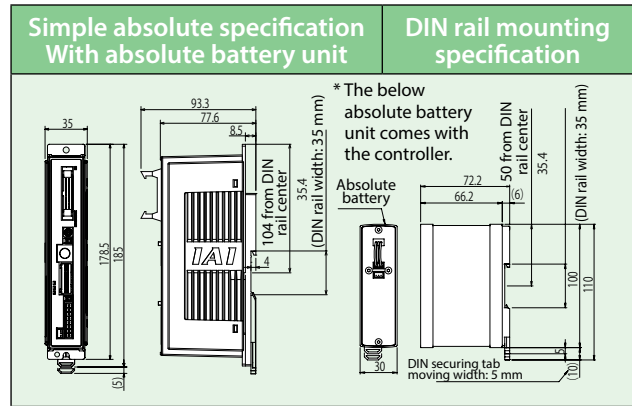
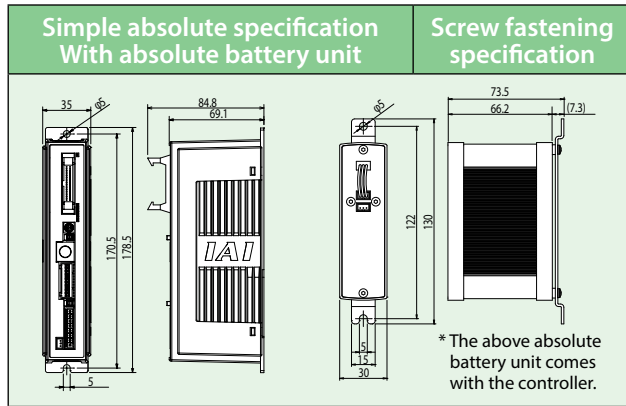
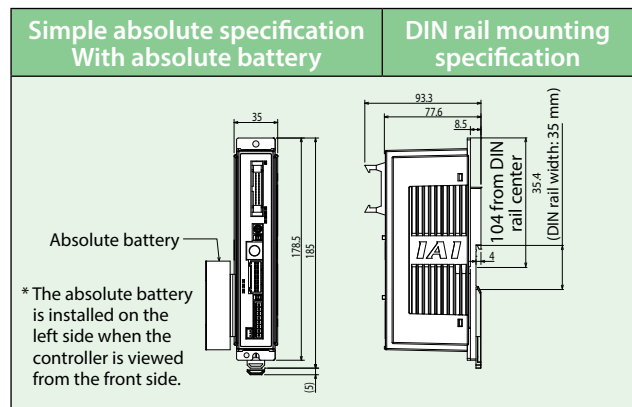
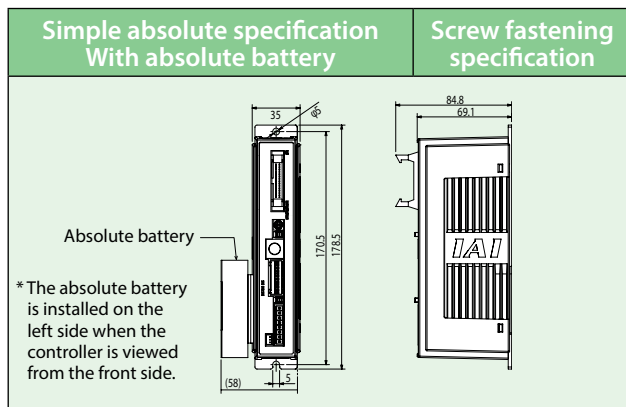
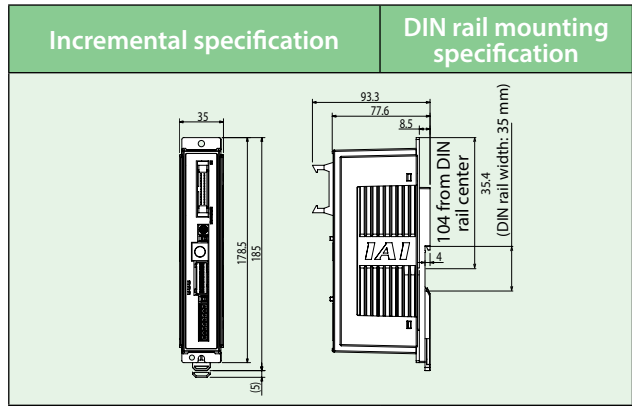
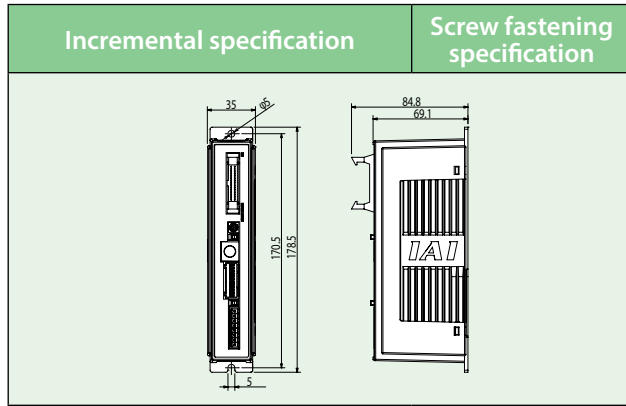

<PCON-CFA>

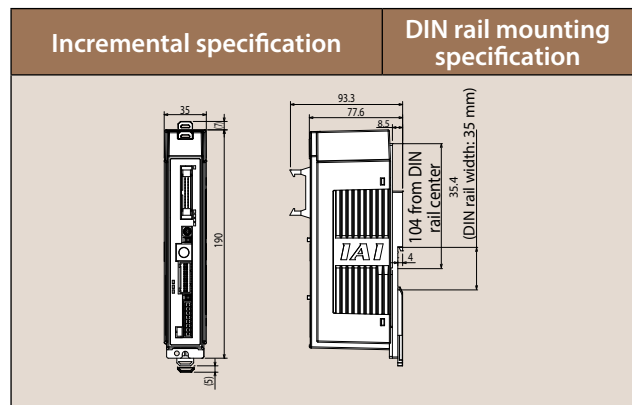
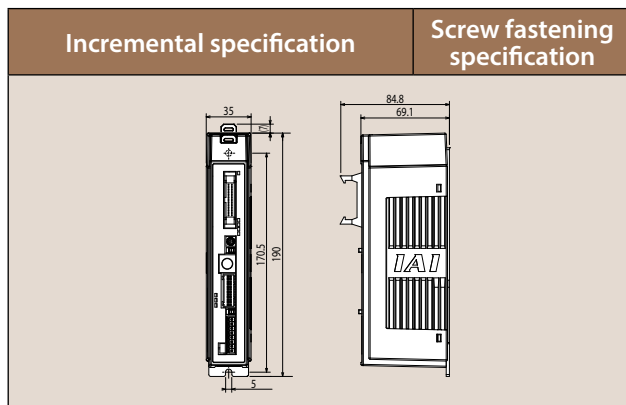

Specification table

Item			Description	
			PCON-CA	PCON-CFA
Number of controlled axes			1 axis	
Power supply voltage			24 VDC ± 10%	
Load capacity (Current consumption of controlled axes included) (Note 1)	RCP2 RCP3	Motor type	20P, 28P, 28SP	1A max.
			42P, 56P	2.2A max.
			60P, 86P	6A max.
	RCP4	Motor type	28P, 35P	High-output setting disabled: 2.2 A max.
			42P, 56P	High-output setting enabled: 3.5 A rated / 4.2 A max.
			60P, 86P	6A max.
Power supply for electromagnetic brake (for actuators with brake)			DC24 VDC ± 10%, 0.15 A (max.)	DC24 VDC ± 10%, 0.5 A (max.)
Rush current (Note 2)			8.3 A	10 A
Momentary power failure resistance			500 μs max.	
Applicable encoder			Incremental encoder of 800 pulses/rev in resolution	
Actuator cable length			20 m max.	
External interface	PIO specification		Dedicated 24-VDC signal input/output (NPN or PNP selected) --- Up to 16 input points, up to 16 output points / Cable length: 10m max.	
	Field network specification		DeviceNet, CC-Link, PROFIBUS, CompoNET, MECHATROLINK, EtherCAT, EtherNet/IP	
Data setting/input method			PC software, touch-panel teaching pendant	
Data retention memory			Position data and parameters are saved in the non-volatile memory (The memory can be written any number of times.)	
Operation modes			Positioner mode / Pulse-train control mode (Selectable by parameter setting)	
Number of positions in positioner mode			Up to 512 points for the positioner type, up to 768 points for the network type (Note) The number of positioning points varies depending on the PIO pattern selected.	
Pulse-train interface	Input pulse		Differential method (line driver method): 200 kpps max. / Cable length: 10 m max.	
			Open collector method: Not supported * If the host uses open-collector output, convert the open-collector pulses to differential pulses using the AK-04 (available as an option).	
	Command pulse magnification (electronic gear ratio: A/B)		1/50 < A/B < 50/1 Setting range of A and B (set by parameters): 1 to 4096	
	Feedback pulse output		None	
Isolation resistance			500-VDC 100 MΩ or more	
Electric shock protection mechanism			Class I basic isolation	
Mass (Note 3)	Incremental specification		Screw fastening type: 250 g or less DIN rail securing type: 285 g or less	Screw fastening type: 270g or less DIN rail securing type: 305g or less
	Simple absolute specification (190 g of battery weight included)		Screw fastening type: 450 g or less DIN rail securing type: 485 g or less	
Cooling method			Natural air cooling	Forced air cooling
Environment	Ambient operating temperature		0 to 40°C	
	Ambient operating humidity		85%RH or less (non-condensing)	
	Operating ambience		Not exposed to corrosive gases	
	Protection degree		IP20	

Note 1) The value increases by 0.3 A for the field network specification.

Note 2) After the power is turned on, rush current will flow for approx. 5 msec (at 40°C). Take note that the rush current varies depending on the impedance of the power-supply line.

Note 3) The value increases by 30 g for the field network specification.

- Controller
- PMEC
AMEC
- PSEP
ASEP
DSEP
- MSEP
- ERC3
- ERC2
- PCON
-CA
- PCON
- ACON
- SCON
-CA
- MSCON
- PSEL
- ASEL
- SSEL
- XSEL
- PS-24
- Pulse
Motor
- Servo
Motor
(24V)
- Servo
Motor
(200V)
- Linear
Servo
Motor

Options

Teaching pendant

- Summary Teaching device for positioning input, test operation, and monitoring.
- Model **CON-PTA-C** (Touch panel teaching pendant)
CON-T (Standard type)

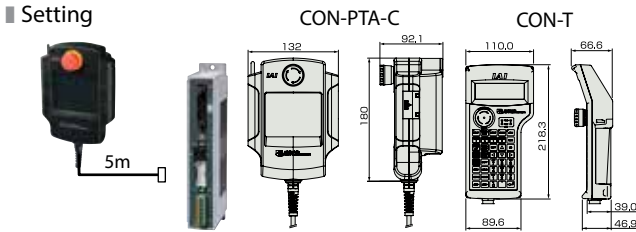

Specification

Item		Content	
Model	English Version	CON-PTA-C-ENG	CON-T-ENG
Data Input		○	○
Actuator Motion		○	○
Ambient Operating Temp./Humidity		Temp 0~40°C; 85% RH or below	
Ambient Operating Atmosphere		No corrosive gases. Especially no dust.	
Protective class		IP40	IP54
Weight		Approx. 570g	Approx. 400g
Cable Length		5m	
Display		65,536 color (16 bit color) White LED back light	20 char. x 4 lines LCD display
Standard Price		—	—

PC software (Windows only)

- Summary A startup support software for inputting positions, performing test runs, and monitoring. With enhancements for adjustment functions, the startup time is shortened.

Supported Windows OS:
2000 SP4 or later / XP SP2 or later / Vista / 7

- Model **RCM-101-MW** (External device communication cable + RS232 conversion unit)

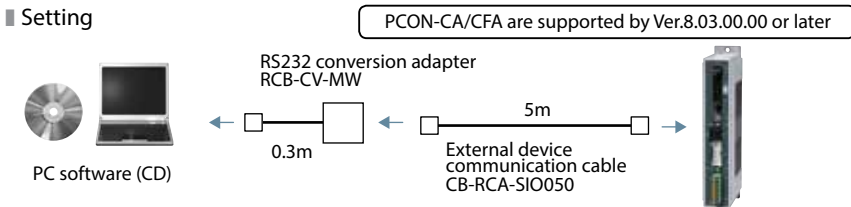

- Model **RCM-101-USB** (External device communication cable + USB converter adaptor + USB cable)

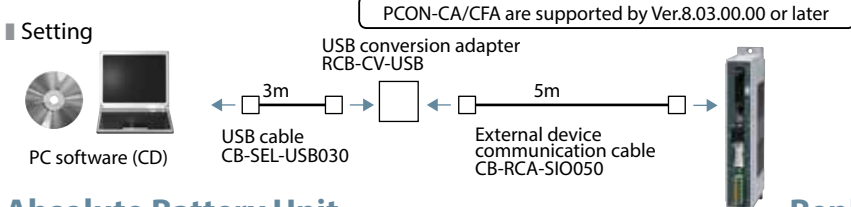

Absolute Battery Unit

- Summary Battery unit that comes with a simple absolute controller, used to back up the current controller position.
- Model **SEP-ABU** (DIN rail mount specification)
SEP-ABUS (screw fixing specification)

Replacement battery

- Summary The replacement battery for the absolute data backup battery box.
- Model **AB-7**



Specifications

Item	Specification
Ambient operating temperature, humidity	0 to 40°C (desirably around 20°C), 95% RH or below (non-condensing)
Operating ambience	Free from corrosive gases
Absolute battery	Model number: AB-7 (Ni-MH battery / Life: Approx. 3 years)
Controller/absolute battery unit link cable	Model number: CB-APSEP-AB005 (Length: 0.5m)
Mass	Standard type: Approx. 230g / Dust-proof type: Approx. 260g

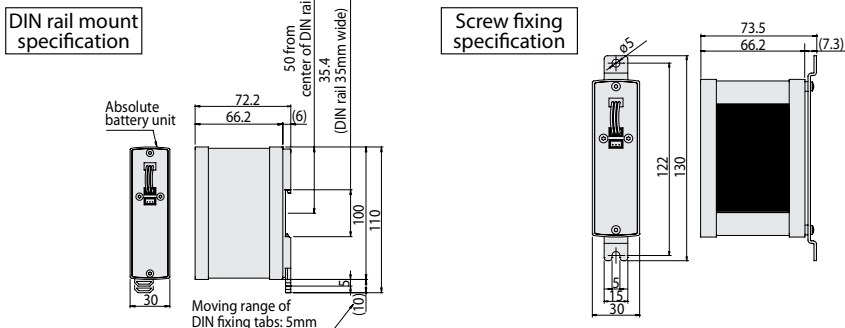

619

PCON-CA / CFA

Service parts

Integrated Motor-Encoder Cable/ Motor-Encoder Robot Cable for RCP4

Model **CB-CA-MPA** / **CB-CA-MPA** -**RB**

*Enter the cable length (L) into . Compatible to a maximum of 20 meters.
Ex: 080 = 8m

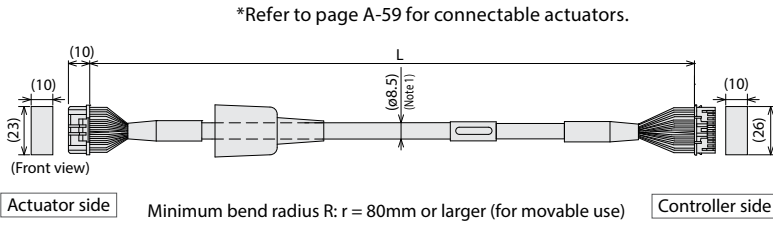

* The robot cable is designed for flex-resistance:
Please use the robot cable if the cable has to be installed through the cable track.

(Note 1) If cable length is 5m or more, non-robotic cable is ø9.1 and robot cable is ø10.

Actuator side 1-1827863-1 (AMP)			Controller side PADP-24V-1-S (JST)		
Pin No.	Signal name	Color	Pin No.	Signal name	Color
A1	ØA/U	Blue(Black)	1	ØA/U	Blue (Black)
B1	VMM/V	Orange (White)	2	VMM/V	Orange (White)
A2	Ø A/W	Green (Brown)	5	Ø A/W	Green (Brown)
B2	ØB/-	Brown (Green)	3	ØB/-	Brown (Green)
A3	VMM/-	Gray (Yellow)	4	VMM/-	Gray (Yellow)
B3	Ø B/-	Red (Red)	6	Ø B/-	Red (Red)
A4	LS+/BK+	Black (Orange)	7	LS+/BK+	Black (Orange)
B4	LS-/BK-	Yellow (Gray)	8	LS-/BK-	Yellow (Gray)
A6	-/A+	Blue (White)	11	-/A+	Blue (White)
B6	-/A-	Orange (Yellow)	12	-/A-	Orange (Yellow)
A7	A+/B+	Green (Red)	13	A+/B+	Green (Red)
B7	A-/B-	Brown (Green)	14	A-/B-	Brown (Green)
A8	B+/Z+	Gray (Black)	15	B+/Z+	Gray (Black)
B8	B-/Z-	Red (Brown)	16	B-/Z-	Red (Brown)
A5	BK+/LS+	Blue (Black)	9	BK+/LS+	Blue (Black)
B5	BK-/LS-	Orange (Brown)	10	BK-/LS-	Orange (Brown)
A9	LS_GND	Green (Green)	18	LS_GND	Green (Green)
B9	VPS	Brown (Red)	17	VPS	Brown (Red)
A10	VCC	Gray (White)	17	VCC	Gray (White)
B10	GND	Red (Yellow)	19	GND	Red (Yellow)
A11	-	-	21	-	-
B11	FG	Black (-)	22	-	-
			23	-	-
			24	FG	Black (-)

* Color in () indicates color of robot cable

Integrated Motor-Encoder Robot Cable/ Motor-Encoder Cable for RCP2-RA10C/HS8/SA16C

Model **CB-CFA-MPA** / **CB-CFA-MPA** -**RB**

*Enter the cable length (L) into . Compatible to a maximum of 20 meters.
Ex: 080 = 8m

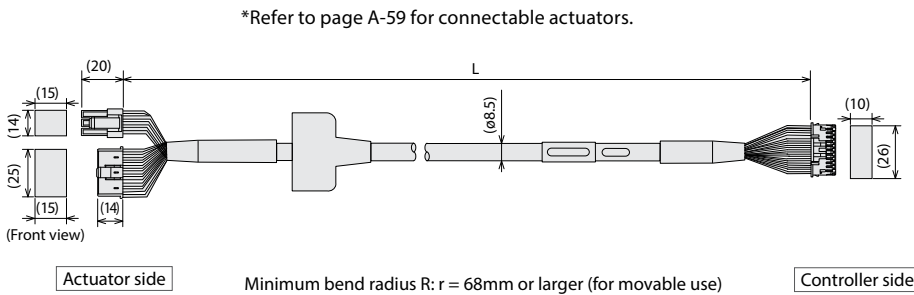

Actuator side SLP-06V (JST)		Controller side PADP-24V-1-S (JST)	
Pin No.	Signal name	Pin No.	Signal name
1	eA	1	eA
2	VMM	2	VMM
4	eB	3	eB
5	VMM	4	VMM
3	e/A	5	e/A
6	e/B	6	e/B
5	NC	11	NC
6	NC	12	NC
13	LS+	7	LS+
14	LS-	8	LS-
1	A+	13	A+
2	A-	14	A-
3	B+	15	B+
4	B-	16	B-
16	BK+	9	BK+
17	BK-	10	BK-
12	VCC	21	VCC
9	GND	19	GND
11	VPS	18	VPS
10	NC	20	NC
18	FG	24	FG
15	NC	17	NC
7	NC	22	NC
8	NC	23	NC

Integrated Motor-Encoder Robot Cable/ Motor-Encoder Cable for RCP3/RCA2 and others

Model **CB-APSEP-MPA** / **CB-APSEP-MPA** -**LC**

*Enter the cable length (L) into . Compatible to a maximum of 20 meters.
Ex: 080 = 8m

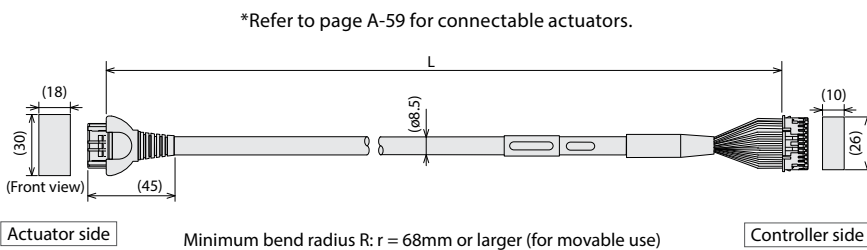

Actuator side Pin number	Signal name	Controller side Pin number
A1	Black (ØA)(U)	1
B1	White (VMM)(V)	2
A2	Brown (ØA)(W)	5
B2	Green (ØB)(-)	3
A3	Yellow (VMM)(-)	4
B3	Red (ØB)(-)	6
A4	Orange (LS+)(BK+)	7
B4	Gray (LS-)(BK-)	8
A6	White (-)(A+)	11
B6	Yellow (-)(A-)	12
A7	Red (A+)(B+)	13
B7	Green (A-)(B-)	14
A8	Black (B+)(Z+)	15
B8	Brown (B-)(Z-)	16
A5	Black (label)(BK+)(LS+)	9
B5	Brown (label)(BK-)(LS-)	10
A9	Green (label)(GNDs)(GNDs)	20
B9	Red (label)(VPS)(VPS)	18
A10	White (label)(VCC)(VCC)	17
B10	Yellow (label)(GND)(GND)	19
A11	NC	21
B11	Shield (FG)(FG)	24
	NC	22
	NC	23

Service parts

Integrated Motor-Encoder Robot Cable for RCP2

Model **CB-PSEP-MPA**

* Robot cable is the standard specification.

*Enter the cable length (L) into . Compatible to a maximum of 20 meters. Ex.: 080=8m

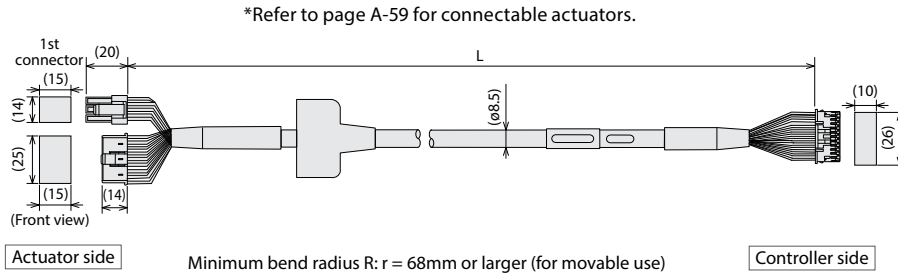

1st Connector	Actuator side Pin number	Color	Controller side Pin number
1	1	Black (0A)	1
2	2	White (VMM)	2
4	4	Red (0B)	3
5	5	Green (VMM)	4
3	3	Brown (0A)	5
6	6	Yellow (0B)	6
16	16	Orange (BK+)	9
17	17	Gray (BK-)	10
5	5	NC	11
6	6	NC	12
13	13	Black (LS+)	7
14	14	Brown (LS-)	8
1	1	White (A+)	13
2	2	Yellow (A-)	14
3	3	Red (B+)	15
4	4	Green (B-)	16
10	10	White (label)(VCC)	17
11	11	Yellow (label)(VPS)	18
9	9	Red (label)(GND)	19
12	12	Green (label)(Spare)	20
15	15	NC	21
7	7	NC	22
8	8	NC	23
18	18	Shield (FG)	24

Integrated Motor-Encoder Robot Cable for RCA

Model **CB-ASEP-MPA**

* Robot cable is the standard specification.

*Enter the cable length (L) into . Compatible to a maximum of 20 meters. Ex.: 080=8m

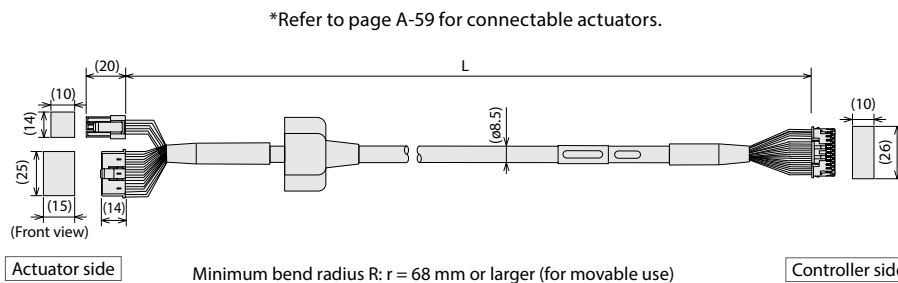

1st Connector	Actuator side Pin number	Color	Controller side Pin number
1	1	Red (U)	1
2	2	Yellow (V)	2
3	3	NC	3
4	4	NC	4
5	5	Black (W)	5
6	6	NC	6
7	7	Orange (BK+)	7
8	8	Gray (BK-)	8
9	9	Black (LS+)	9
10	10	Brown (LS-)	10
11	11	White (A+)	11
12	12	Yellow (A-)	12
13	13	Red (B+)	13
14	14	Green (B-)	14
15	15	Black (label)(Z+)	15
16	16	Brown (label)(Z-)	16
17	17	White (label)(VCC)	17
18	18	Yellow (label)(VPS)	18
19	19	Red (label)(GND)	19
20	20	Green (label)(Spare)	20
21	21	NC	21
22	22	NC	22
23	23	NC	23
24	24	Shield (FG)	24

Integrated Motor-Encoder Robot Cable for RCP2 small rotary

Model **CB-RPSEP-MPA**

* Robot cable is the standard specification.

*Enter the cable length (L) into . Compatible to a maximum of 20 meters. Ex.: 080=8m

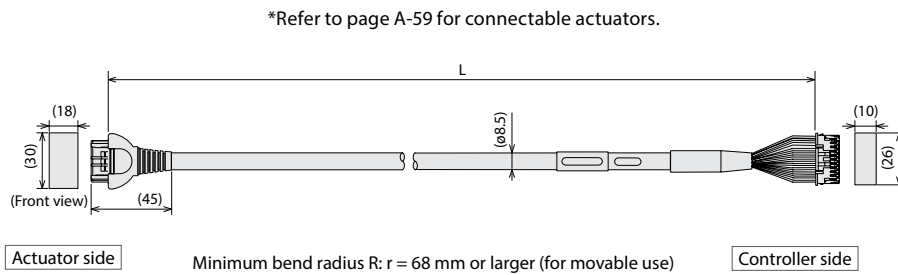

Actuator side Pin number	Color	Controller side Pin number
A1	Black (0A)	1
B1	White (VMM)	2
A2	Brown (0A)	3
B2	Green (0B)	4
A3	Yellow (VMM)	5
B3	Red (0B)	6
A6	Orange (LS+)	7
B6	Gray (LS-)	8
A7	Red (A+)	13
B7	Green (A-)	14
A8	Black (B+)	15
B8	Brown (B-)	16
A4	NC	-
B4	NC	-
A5	Black (label)(BK+)	9
B5	Brown (label)(BK-)	10
A9	Green (label)(GNDLS)	20
B9	Red (label)(VPS)	18
A10	White (label)(VCC)	17
B10	Yellow (label)(GND)	19
A11	NC	21
B11	Shield (FG) (FG)	24
	NC	22
	NC	23

I/O Flat Cable

Model **CB-PAC-PIO**

* indicates the cable length (L). A desired length can be specified up to 10m. Example: 080=8m

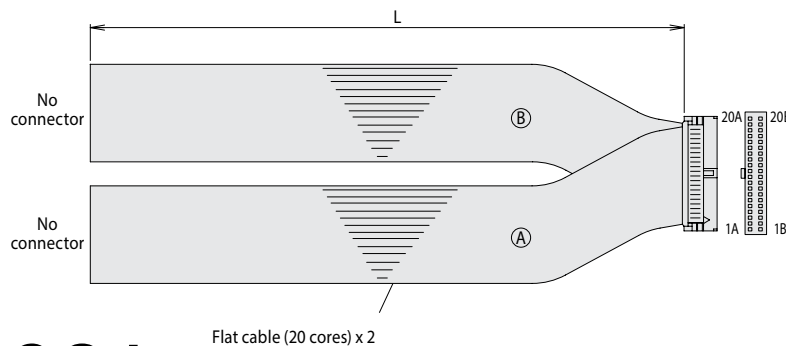

HIF6-40D-1.27R

No.	Signal name	Cable color	Wiring
1A	24V	Brown - 1	
2A	24V	Red - 1	
3A	Pulse	Orange - 1	
4A	Input	Yellow - 1	
5A	IN0	Green - 1	
6A	IN1	Blue - 1	
7A	IN2	Purple - 1	
8A	IN3	Gray - 1	
9A	IN4	White - 1	
10A	IN5	Black - 1	
11A	IN6	Brown - 2	
12A	IN7	Red - 2	
13A	IN8	Orange - 2	
14A	IN9	Yellow - 2	
15A	IN10	Green - 2	
16A	IN11	Blue - 2	
17A	IN12	Purple - 2	
18A	IN13	Gray - 2	
19A	IN14	White - 2	
20A	IN15	Black - 2	

No.	Signal name	Cable color	Wiring
18	OUT0	Brown - 3	
28	OUT1	Red - 3	
38	OUT2	Orange - 3	
48	OUT3	Yellow - 3	
58	OUT4	Green - 3	
68	OUT5	Blue - 3	
78	OUT6	Purple - 3	
88	OUT7	Gray - 3	
98	OUT8	White - 3	
108	OUT9	Black - 3	
118	OUT10	Brown - 4	
128	OUT11	Red - 4	
138	OUT12	Orange - 4	
148	OUT13	Yellow - 4	
158	OUT14	Green - 4	
168	OUT15	Blue - 4	
178	Pulse	Purple - 4	
188	Input	Gray - 4	
198	0V	White - 4	
208	0V	Black - 4	

Flat cable (20 cores) (crimped)

Flat cable (20 cores) (crimped) AWG 28

MEMO

Controller

PMEC
AMEC

PSEP
ASEP
DSEP

MSEP

ERC3

ERC2

**PCON
-CA**

PCON

ACON

SCON
-CA

MSCON

PSEL

ASEL

SSEL

XSEL

PS-24

Pulse
Motor

Servo
Motor
(24V)

Servo
Motor
(200V)

Linear
Servo
Motor



PCON-CA/CFA



ELECTROMATE

Toll Free Phone (877) SERV098
Toll Free Fax (877) SERV099
www.electromate.com
sales@electromate.com

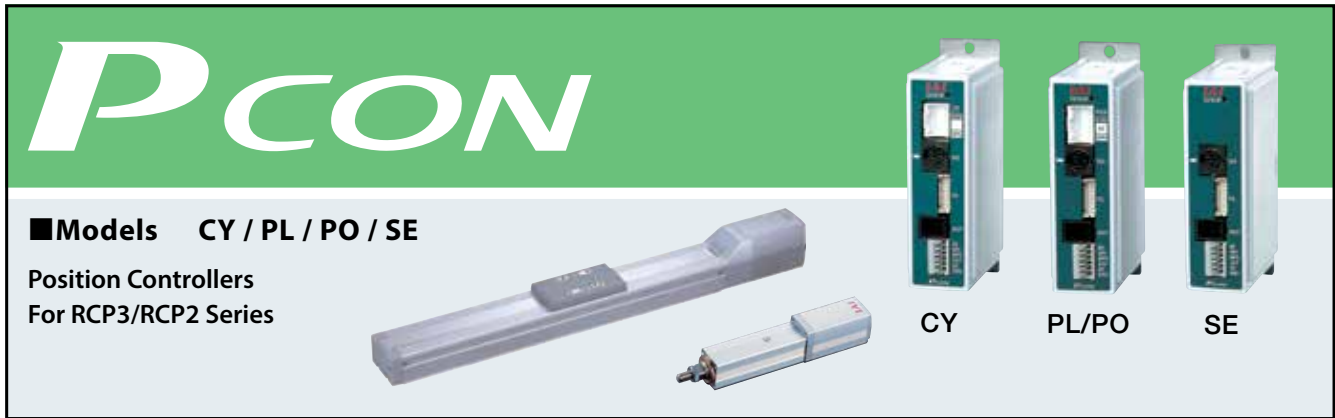

List of models

These are the position controllers that can be used with the RCP3/RCP2 Series actuators. Our line-up has 3 types, which are compatible with various control systems.

Type	CY	PL/PO	SE
Name	Solenoid type	Pulse train control type	Serial communication type
External view			
Description	Can be operated using the same control as the air cylinder type	For pulse train control	For serial communication
Position Points	3 points	—	64 points
Standard Price	—	—	—

Model

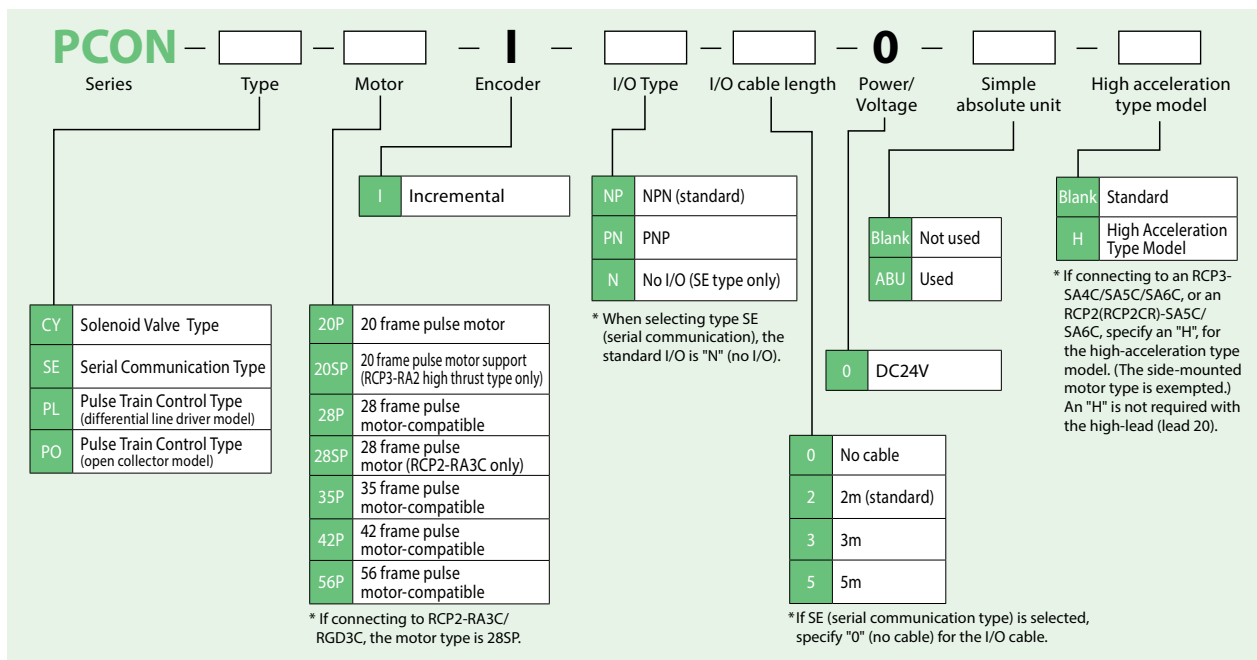

System Configuration

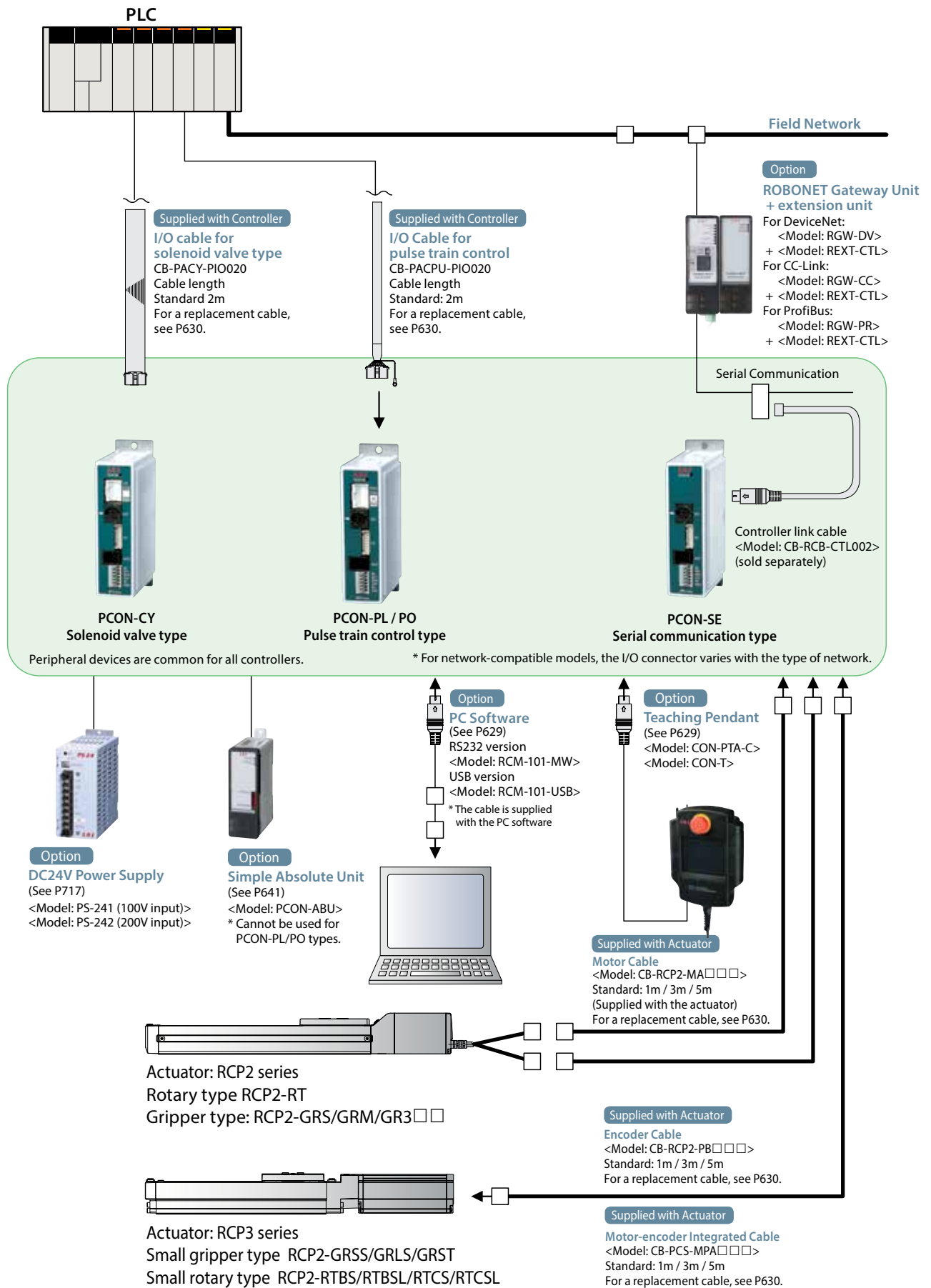

I/O Specification

Input section External input specifications

Item	Specifications
Input voltage	DC24V ±10%
Input current	4mA/circuit
Leak current	1mA max./point
Isolation method	Photocoupler

Output section External output specifications

Item	Specifications
Load Voltage	DC24V
Max. load current	50mA/point
Remaining voltage	2V or less
Isolation method	Photocoupler

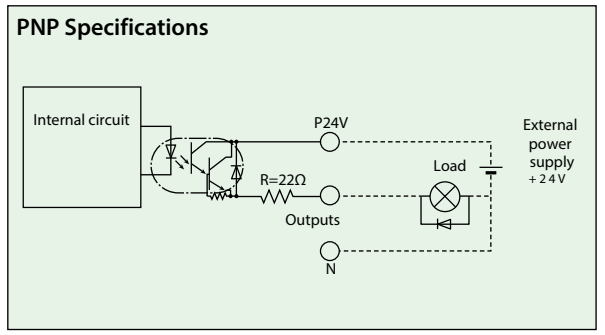
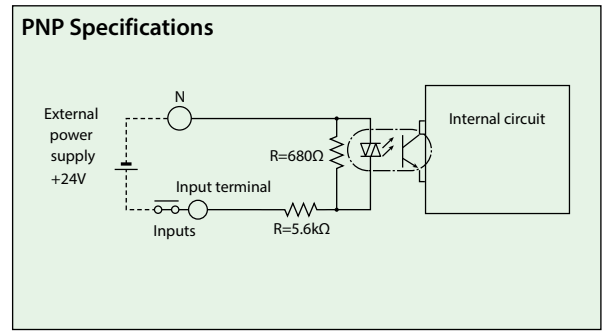
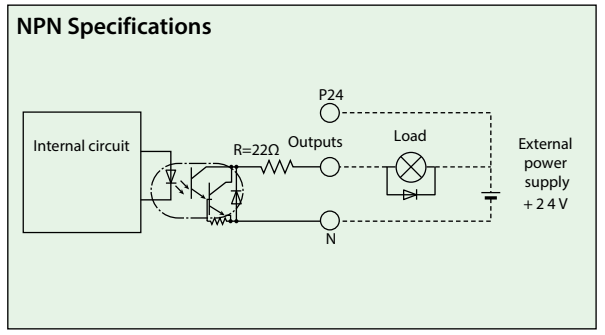
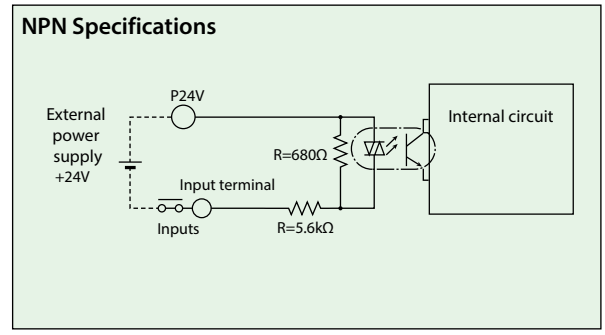

I/O Specification

The 3 types of controllers (CY, PL/PO, and SE) are classified by their respective I/O specifications. In addition, with the positioner type and solenoid valve type, the I/O signal details can be changed via the controller settings. As a result, a number of functions can be used.

Control Function by Type

Type	CY	PL/PO	SE	Features
Name	Solenoid valve type	Pulse in-line control type	Serial communication type	
Positioner mode	×	×	○ (*1)	This is the basic operating mode, in which the user designates position numbers and inputs start signals.
Teaching mode	×	×	○ (*1)	In this mode, the slider (rod) moves based on an external signal, and the stopped positions can be registered as position data.
Solenoid valve mode	○	×	○ (*1)	The actuator can be moved simply by ON/OFF of position signals. This mode supports the same control signals you are already familiar with on solenoid valves of air cylinders.
Pulse train mode	×	○	×	In this mode, you can operate the actuator freely using pulse trains without inputting position data.
Network compatible	×	×	○ (*2)	The controller can be connected to a DeviceNet or CC-Link network.

*1 Operates using network communications or serial communications.
 *2 Can make a direct connection to a field network with the network specifications.

Explanation of I/O Signal Functions

The table below explains the functions allocated to the controller's I/O signal. Since the signals that can be used vary depending on the controller type and settings, check the signal table for each controller to confirm the available functions.

Signal Function Description

Classification	Signal abbreviations	Signal	Function description
Input	CSTR	PTP strobe signal (start signal)	Input this signal to cause the actuator to start moving to the position set by the command position number signal.
	PC1 to PC256	Command position number signal	This signal is used to input a target position number (binary input).
	BKRL	Brake forced release signal	This signal forcibly releases the brake.
	RMOD	Running mode switching signal	This signal can switch the running mode when the MODE switch on the controller is set to AUTO. (AUTO when this signal is OFF, or MANU when the signal is ON)
	*STP	Pause signal	Turning this signal OFF causes the moving actuator to decelerate to a stop. The actuator will resume the remaining movement if the signal is turned ON during the pause.
	RES	Reset signal	Turning this signal ON resets the alarms that are present. If this signal is turned ON while the actuator is paused (*STP is OFF), the remaining movement can be cancelled.
	SON	Servo ON signal	The servo remains on while this signal is ON, or off while the signal is OFF.
	HOME	Home return signal	Turning this signal ON performs home-return operation.
	MODE	Teaching mode signal	Turning this signal ON switches the controller to the teaching mode. (provided that CSTR, JOG+ and JOG- are all OFF and the actuator is not moving).
	JISL	JOG/INCHING switching signal	When the main signal is off, the JOG operation will be conducted for JOG+ and JOG-. When the signal is on, the unit will do the inching operation for JOG+ and JOG-.
	JOG+, JOG-	JOG signal	When the JISL signal is off and the JOG +/- signal turns on, the unit will jog in the + (positive) direction when the JOG + turns on and the - (negative) direction when the JOG - turns on. During the JOG operation, the unit slows to a stop when the JOG +/- signal turns off.
	PWRT	Teaching signal	In the teaching mode, specify a desired position number and then turn this signal ON for at least 20ms to write the current position to the specified position number.
	ST0 to ST6	Start position command	Turning this signal ON in the solenoid valve mode causes the actuator to move to the specified position. (Start signal is not required)
	TL	Torque limit selection signal	While this signal is ON, torque is limited by the value set by a parameter. The TLR signal turns on if torque has reached the specified value.
	DCLR	Deviation counter clear signal	The position deviation counter is continuously cleared while this signal is ON.
Output	PEND/INP	In position signal	This signal turns ON when the actuator has entered the positioning band after movement. If the actuator has exceeded the positioning band, PEND does not turn OFF, but INP does. PEND and INP can be swapped within parameters.
	PM1 to PM256	Positioning complete signal	This signal is used to output the position number achieved at the completion of positioning (binary output)
	HEND	Home return completion signal	This signal turns ON upon completion of home return.
	ZONE1	Zone signal	This signal turns ON when the current actuator position has entered the range specified by the parameters.
	PZONE	Position zone signal	Turns ON when the actuator moves into a position within the range of the target position data that was set. PZONE can be used together with ZONE1, but PZONE is valid only during movement to a specified position.
	RMDS	Running mode status signal	This outputs the operation mode status.
	*ALM	Controller alarm status signal	This signal remains ON while the controller is not in the alarm condition, and turns OFF when an alarm has occurred.
	MOVE	Moving signal	Turns ON while the actuator is moving (home return), including when there is push force.
	SV	Servo ON status signal	This signal turns ON when servo is ON.
	*EMGS	Emergency stop status signal	This signal remains ON while the controller is not in the emergency stop mode, and turns OFF once an emergency stop has been actuated.
	MODES	Mode status signal	The mode signal input turns it ON when it goes into teaching mode. It turns OFF when it goes into normal mode.
	WEND	Writing complete signal	This signal remains OFF after the controller has switched to the teaching mode. It turns ON upon completion of data write using the PWRT signal. If the PWRT signal is turned Off, this signal also turns OFF.
	PE0 to PE6	Current position number signal	This signal turns ON after the controller has completed moving to the target position in the solenoid valve mode.
	TLR	Torque limiting signal	This signal turns ON once the motor torque has reached the specified value in a condition where torque is being limited by the TL signal.
	LSO to LS2	Limit switch output signal	Each signal turns ON when the current actuator position has entered the positioning band before or after the target position. If the actuator has already completed home return, these signals are output even before a movement command is issued or while the servo is OFF.
	LOAD	Load output determination status signal	This signal turns ON once the motor torque has reached the specified value. (*PCON-CF dedicated signal)
	TRQS	Torque level status signal	Turns ON when the motor current reaches the threshold. (*PCON-CF dedicated signal)

- Controller
- PMEC AMEC
- PSEP ASEP DSEP
- MSEP
- ERC3
- ERC2
- PCON -CA
- PCON
- ACON
- SCON -CA
- MSCON
- PSEL
- ASEL
- SSEL
- XSEL
- PS-24
- Pulse Motor
- Servo Motor (24V)
- Servo Motor (200V)
- Linear Servo Motor

I/O Signal Table

■ Solenoid valve type (PCON-CY)

Pin No.	Classification		Parameters (select PIO pattern)	
			0	1
			Solenoid valve mode 0	Solenoid valve mode 1
		Positioning Points	3 points	3 points
		Zone signal	×	×
		P-zone signal	×	○
1	24V			
2	0V			
3	Input	IN0	ST0	ST0
4		IN1	ST1 (JOG+)	ST1 (JOG+)
5		IN2	ST2 (RES)	ST2 (RES)
6	Output	IN3	SON	SON
7		OUT0	LS0	PE0
8		OUT1	LS1 (TRQS)	PE1 (TRQS)
9		OUT2	LS2 (-)	PE2 (-)
10		OUT3	SV	PZONE
11		OUT4	HEND	HEND
12	OUT5	* ALM	* ALM	

(Note) The names of signals above inside () are functions before the unit returns home.
 (Note) Signals with asterisks (*) are normally ON, and OFF during operation.

■ Pulse Train Type (PCON-PL/PO)

Pin No.	Classification		Parameters (select PIO pattern)	
			0	1
			Standard mode	Push mode
		Positioning Points	—	—
		Zone signal	×	×
		P-zone signal	×	×
1	24V			
2	0V			
3	Input	IN0	SON	ON
4		IN1	TL	TL
5		IN2	HOME	HOME
6	Output	IN3	RES	RES / DCLR
7		OUT0	SV	SV
8		OUT1	INP	INP / TLR
9		OUT2	HEND	HEND
10		OUT3	* ALM	* ALM
11		Input		* PP
12			PP	PP
13			* NP	* NP
14			NP	NP

(Note) Signals with asterisks (*) are normally ON, and OFF during operation.

Pulse Train Input Wiring Diagram

■ Differential Receiver Method (PCON-PL)

Max. input pulse frequency : Max. 200 kpps
 Cable Length : Max. 10m

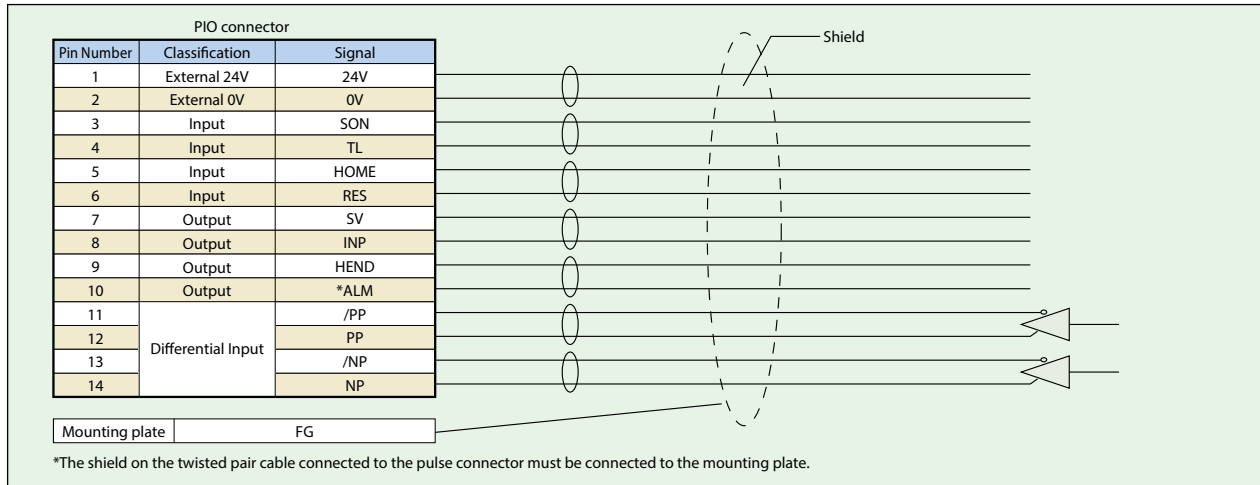

■ Open Collector Method (PCON-PO)

Max. input pulse frequency : Max. 60 kpps
 Cable Length : Max. 2m

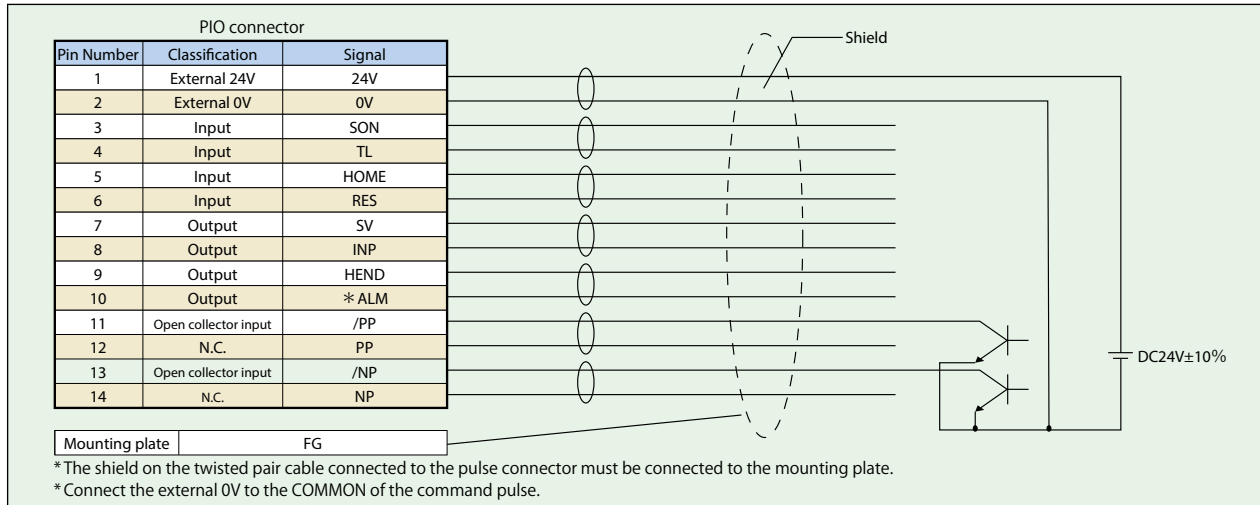

Command Pulse Input State

Command pulse train state		Input terminal	During forward operation	During reversed operation
Negative logic	Forward pulse train	PP-/PP		
	Reversed pulse train	NP-/NP		
	The forward pulse train causes the motor to rotate forward, and the reverse pulse train causes the motor to rotate in reverse.			
	Pulse train	PP-/PP		
	Symbols	NP-/NP	Low	High
	The command pulse is used for the amount of motor rotation, and the command symbol is used for rotational direction.			
	A/B phase pulse train	PP-/PP		
Positive logic	Forward pulse train	PP-/PP		
	Reversed pulse train	NP-/NP		
	The forward pulse train causes the motor to rotate forward, and the reverse pulse train causes the motor to rotate in reverse.			
	Pulse train	PP-/PP		
	Symbols	NP-/NP	High	Low
	The command pulse is used for the amount of motor rotation, and the command symbol is used for rotational direction.			
	A/B phase pulse train	PP-/PP		
An A/B phase pulse with a 90° phase difference (multiplier is 4) is used to generate commands for the amount of rotation and rotational direction.				

*The number of encoder pulse for the RCP3, RCP2 series operable with PCON is 800 in all models.

Table Of Specifications

Item	Specifications			
Controller type	CY	PL	PO	SE
Connected actuator (*1)	RCP3/RCP2 series actuator (Note 1)			
Number of control axes	1-axis			
Operating method	Solenoid valve type	Pulse train input type		Serial communication type
Positioning Points	3 points	—		64 points
Backup memory	EEPROM			
I/O connector	12-pin connector	14-pin connector		None
Number of I/O	4 input points/6 output points	4 input points/4 output points		None
I/O power	External supply DC24V±10%			—
Serial Communication	RS485 1ch			
Peripheral device communication cable	CB-PACY-PIO□□□	CB-PACPU-PIO□□□		CB-RCB-CTL002
Command pulse train input method	—	Differential line driver	Open collector	—
Max. input pulse frequency (Note 2)	—	Max. 200 kpps	Max. 60 kpps	—
Position detection method	Incremental encoder			
Drive-source cutoff relay at emergency stop	External			
Forced release of electromagnetic brake	ON/OFF terminal signal inside the power terminal for brake release			
Input Supply Voltage	DC 24 V ± 10%			
Power Supply Capacity	2A max.			
Dielectric strength voltage	DC500V 1MΩ			
Vibration resistance	XYZ directions	10 to 57Hz, One side amplitude: 0.035mm (continuous), 0.075mm (intermittent) 58 to 150Hz, 4.9m/s ² (continuous), 9.8m/s ² (intermittent)		
Ambient operating temperature	0~40°C			
Ambient operating humidity	10 - 95% (non-condensing)			
Ambient operating atmosphere	Without corrosion gases			
Protection class	IP20			
Weight	Approx. 130g			

(Note 1) The high-thrust type (RA10C), high-speed type (HS8C/HS8R) and waterproof type (RCP2W-SA16) cannot be operated.

(Note 2) With the open collector specification, keep the maximum input frequency to 60 kpps or below to prevent malfunction. For applications exceeding 60kpps, use the differential line driver.

- PMEC AMEC
- PSEP ASEP DSEP
- MSEP
- ERC3
- ERC2
- PCON -CA
- PCON
- ACON
- SCON -CA
- MSCON
- PSEL
- ASEL
- SSEL
- XSEL
- PS-24

Dimensions Name of each part

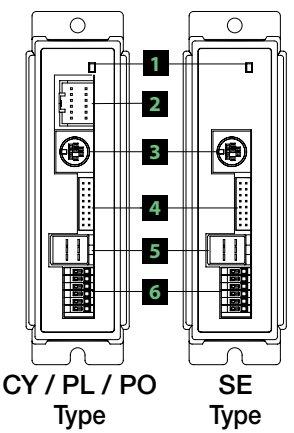
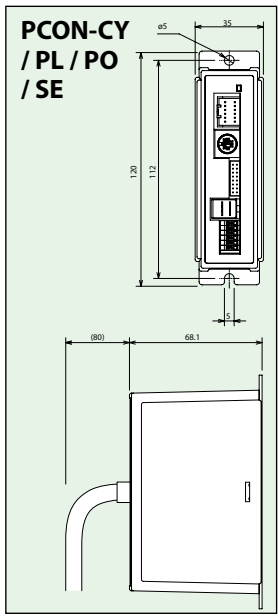

CY / PL / PO Type
 * PIO connectors are:
 CY: 12 pin
 PL/PO: 14 pin

1 LED display

These LED colors indicate the condition of the controller.
 Lit (green) Servo ON Lit (red) Alarm activated Unlit Servo OFF Blinking (green) Automatic servo-OFF
 Emergency stop

2 PIO connector

Connects a cable for communicating with a PLC or other external equipment.

3 SIO connector

Connects a teaching pendant, PC cable, controller, or gateway unit to a controller.

4 Encoder brake connector

Connects the encoder/brake cable for the actuator.

5 Motor connector

Connects the motor cable for the actuator.

6 Power terminal block

Main power for controller(s), emergency stop.

Pin No.	Signal	Name	Note
1	SGA	Positive side, RS485 differential signal	
2	SGB	Negative side, RS485 differential signal	
3	5V	+5V output	For RS232/485 conversion
4	ENBL	Enable signal	
5	EMGA	EMG line connection to external equipment	
6	24V	24-V power for T/P	For T/P
7	0V	GND	
8	EMGB	EMG line connection to external equipment	
9	0V	EMG line connection to external equipment ground	

CY / PL / PO / SE type

Terminal number	Signal	Name
6	BK	BK release
5	MPI	Motor drive-source cutoff terminal
4	MPO	Motor drive-source cutoff terminal
3	24V	Positive side of the 24-V power supply
2	0V	Negative side of the 24-V power supply
1	EMG	EMG signal (application of 24 V)

Options

Teaching pendant

- Summary Teaching device for positioning input, test operation, and monitoring.
- Model **CON-PTA-C** (Touch panel teaching pendant)
CON-T (Standard type)
- Setting

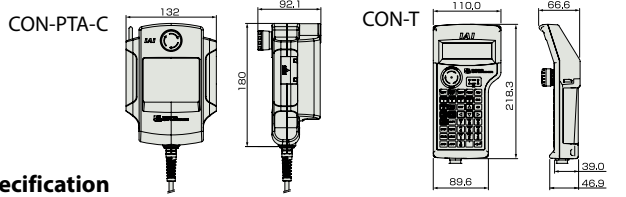
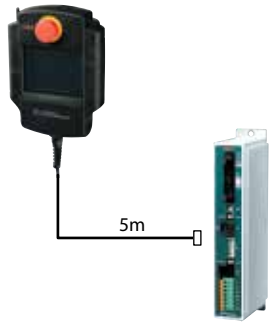

Specification

Item		Content	
Model	English Version	CON-PTA-C-ENG	CON-T-ENG
Data Input		○	○
Actuator Motion		○	○
Ambient Operating Temp./Humidity		Temp 0~40°C; 85% RH or below	
Ambient Operating Atmosphere		No corrosive gases. Especially no dust.	
Protective class		IP40	IP54
Weight		Approx. 570g	Approx. 400g
Cable Length		5m	
Display		65,536 color (16 bit color) White LED back light	20 char. x 4 lines LCD display
Standard Price		—	—

PC software (Windows only)

- Summary A startup support software for inputting positions, performing test runs, and monitoring. With enhancements for adjustment functions, the startup time is shortened.
- Model **RCM-101-MW** (External device communication cable + RS232 conversion unit)

Supported Windows OS:
2000 SP4 or later / XP SP2 or later / Vista / 7

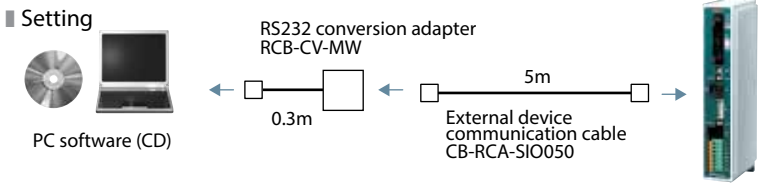

- Model **RCM-101-USB** (External device communication cable + USB converter adaptor + USB cable)

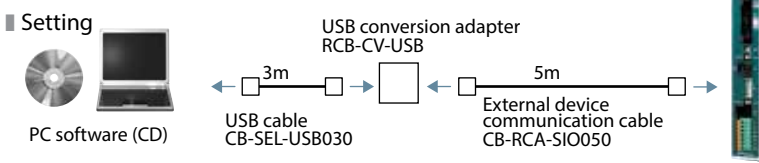

Spare Parts

When you need spare parts after purchasing the product, such as when replacing a cable, refer to the list of models below.
 (* See page A-59 for connectable actuators.)

Motor Robot Cable for RCP2

Model **CB-RCP2-MA** *The standard cable for the motor cable is the robot cable. *Enter the cable length (L) into . Compatible to a maximum of 20 meters. Ex.: 080 = 8m

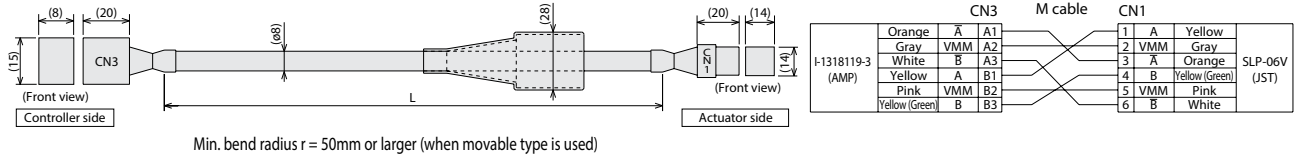

Encoder Cable/Encoder Robot Cable for RCP2

Model **CB-RCP2-PB** / **CB-RCP2-PB** -RB *The standard cable for the encoder cable is the normal cable. A robot cable can be specified as an option. *Enter the cable length (L) into . Compatible to a maximum of 20 meters. Ex.: 080 = 8m

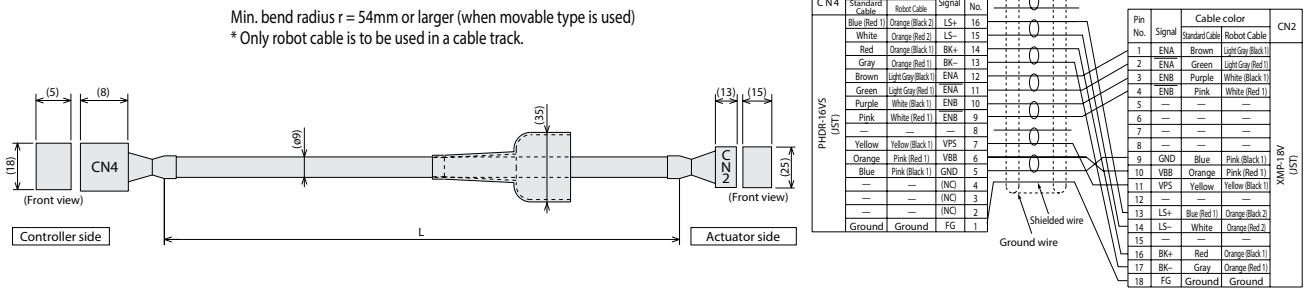

Motor-Encoder Integrated Type Cable for RCP3/RCP2 (Limited to RCP2-GRSS/GRLS/GRST/SRA4R/SRGS4R/SRGD4R)

Model **CB-PCS-MPA** *The standard cable is robot cable. *Enter the cable length (L) into . Compatible to a maximum of 20 meters. Ex.: 080 = 8m

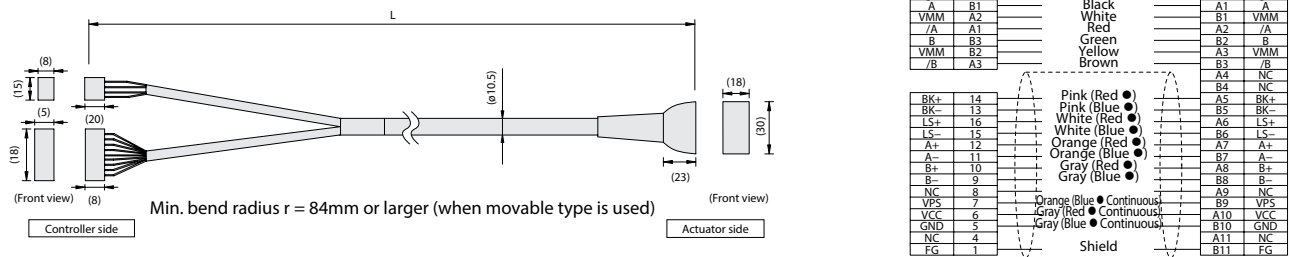

Solenoid Valve Type I/O Cable (for PCON-CY)

Model **CB-PACY-PIO** *Enter the cable length (L) into . Compatible to a maximum of 10 meters. Ex.: 080 = 8m

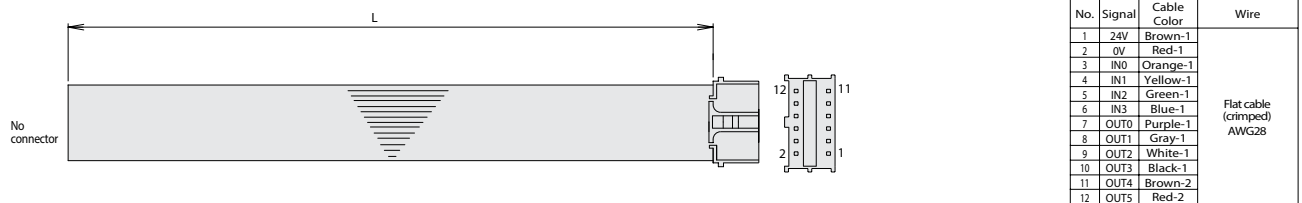

Pulse Train Control I/O Cable (for PCON-PL/PO)

Model **CB-PACPU-PIO** *Enter the cable length (L) into . Compatible to a maximum of 10 meters. Ex.: 080 = 8m

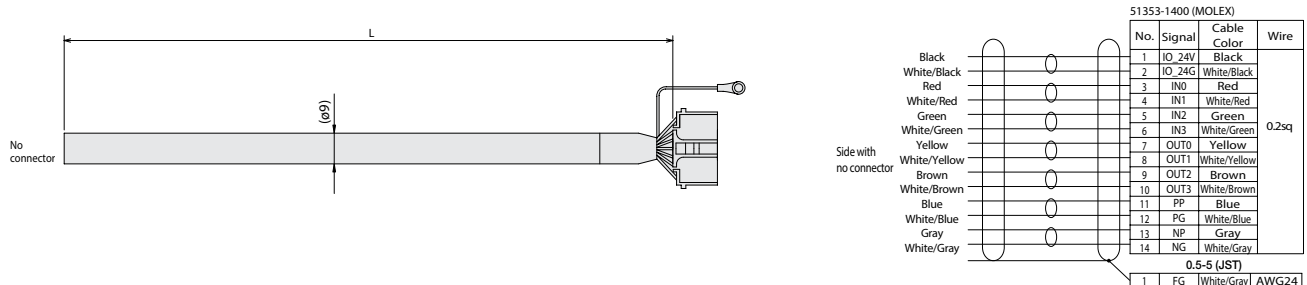

- Controller
- PMEC
AMEC
- PSEP
ASEP
DSEP
- MSEP
- ERC3
- ERC2
- PCON
-CA
- PCON
- ACON
- SCON
-CA
- MSCON
- PSEL
- ASEL
- SSEL
- XSEL
- PS-24
- Pulse Motor
- Servo Motor (24V)
- Servo Motor (200V)
- Linear Servo Motor

ACON

■ Models C / CG / CY / PL / PO / SE

Position Controllers
For RCA2/RCA









C/CG CY PL/PO SE

List of models

This position controller enables movement of the RCA2/RCA series actuators. A line-up of 5 types to support various controlling methods.

Type	C	CG	CY	PL/PO	SE
Name	Positioner type	Safety category compatible type	Solenoid valve type	Pulse train control type	Serial Communication Type
External view					
Description	Positioner capable of a maximum of 512 points of positioning	Conforming to type C safety category specifications	Can be operated using the same control as the air cylinder type	For pulse train control	For serial communication
Position points	512 points	512 points	3 points	(—)	64 points
Standard price	—	—	—	—	—

Model

ACON — [] — [] | [] — [] — [] — **0** — []

Series Type Motor Encoder Option I/O Type I/O Cable Length Power Voltage Simple absolute unit

I Incremental

*The absolute-type RCA actuators cannot be operated with the ACON controller. To operate an absolute-type actuator, use the ASEL controller. However, you can operate a simple absolute-type actuator, in which a simple absolute unit is attached to an incremental actuator.

C	Positioner Type
CG	Safety-compliant type
CY	Solenoid Valve Type
SE	Serial Communication Type
PL	Pulse Train Control Type (differential line driver model)
PO	Pulse Train Control Type (open collector model)

HA	High Accel./Decel.
LA	Power-saving

2	2W motor-compatible
5	5W motor-compatible
10	10W motor-compatible
20S	20W motor-compatible (*)
20	20W motor-compatible
30	30W motor-compatible

* When connecting an RCA-RA3□/ RGS3□/RGD3□ and RCA2-SA4□/TA5□, the motor type is 20S.

NP	NPN (standard)
PN	PNP
DV	DeviceNet
CN	CompoNet connection model
CC	CC-Link
ML	MECHATROLINK connection model
PR	ProfiBus
EC	EtherCAT
EP	EtherNet/IP
N	No I/O (SE type only)

* The network models (DV/CC/PR/ML/CN/EC/EP) support C/CG types only.

* When selecting type SE (serial communication), the standard I/O is "N" (no I/O).

Blank	Not used
ABU	Used

0	DC24V
---	-------

0	No cable
2	2m (standard)
3	3m
5	5m

* If SE (serial communication type), and the network model I/O type DV, CN, CC, ML, PR, EC, or EP) is selected, specify "0" (no cable) for the I/O cable.

System Configuration

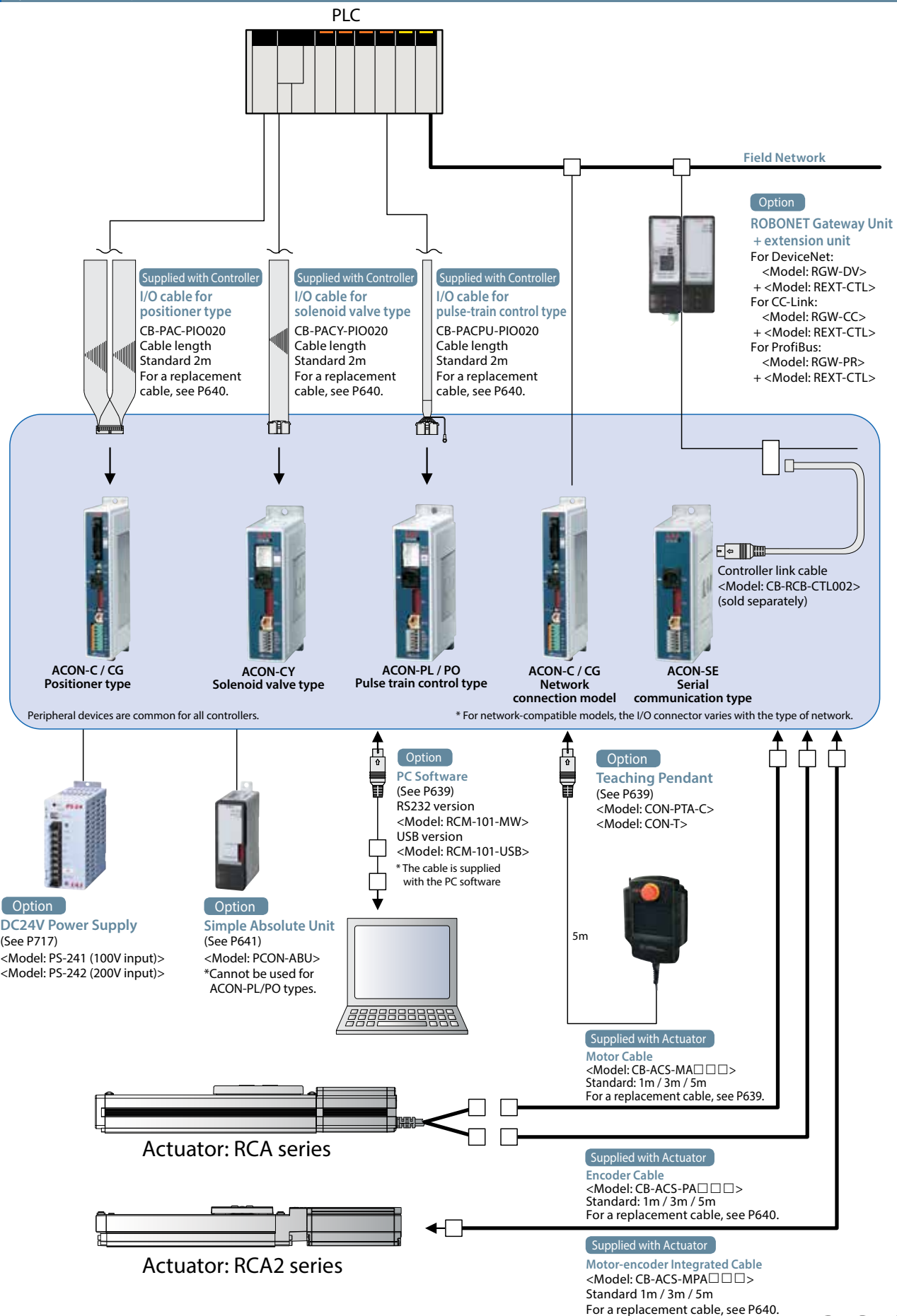

- Controller
- PMEC
AMEC
- PSEP
ASEP
DSEP
- MSEP
- ERC3
- ERC2
- PCON
-CA
- PCON
- ACON
- SCON
-CA
- MCON
- PSEL
- ASEL
- SSEL
- XSEL
- PS-24
- Pulse Motor
- Servo Motor (24V)
- Servo Motor (200V)
- Linear Servo Motor

I/O Specification

Input section External input specifications

Item	Specifications
Input voltage	DC24V +/-10%
Input current	4mA/circuit
Leak current	1mA max./point
Isolation method	Photocoupler

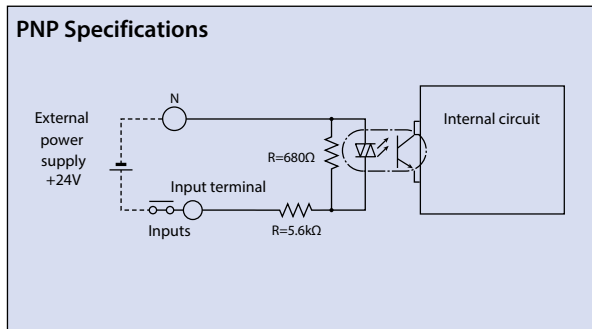
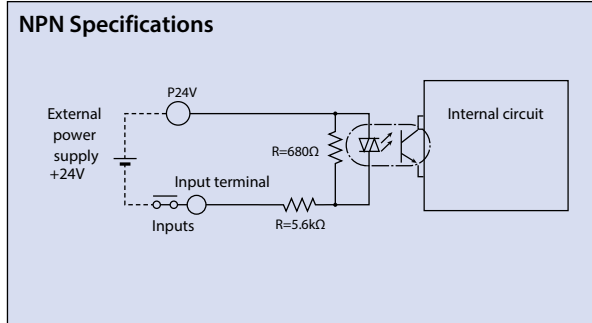

Output section External output specifications

Item	Specifications
Load Voltage	DC24V
Max. load current	50mA/point
Remaining voltage	2V or less
Isolation method	Photocoupler

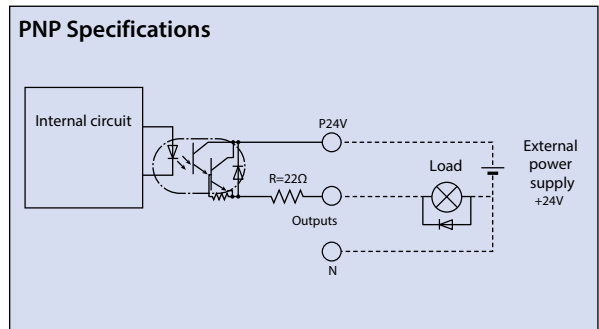
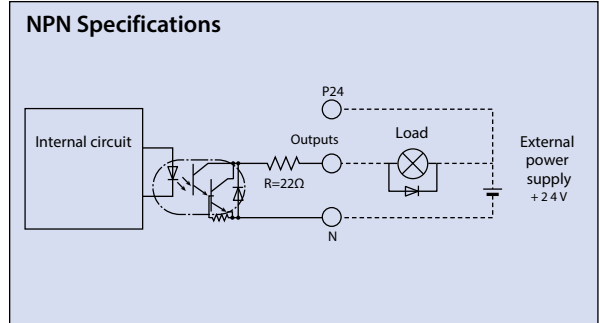

I/O Specification

The 4 types of controllers (C/CG, CY, PL/PO, and SE) are classified by their respective I/O specifications. Also, for the positioner type and solenoid valve type, the I/O signal information can be changed in the controller settings, so multiple functions can be effectively used.

Control Function by Type

Type	CY	PL/PO	SE	Features
Name	Solenoid valve type	Pulse in-line control type	Serial communication type	
Positioner mode	×	×	○ (*1)	This is the basic operating mode, in which the user designates position numbers and inputs start signals.
Teaching mode	×	×	○ (*1)	In this mode, the slider (rod) moves based on an external signal, and the stopped positions can be registered as position data.
Solenoid valve mode	○	×	○ (*1)	The actuator can be moved simply by ON/OFF of position signals. This mode supports the same control signals you are already familiar with on solenoid valves of air cylinders.
Pulse train mode	×	○	×	In this mode, you can operate the actuator freely using pulse trains without inputting position data.
Network compatible	×	×	○ (*3)	The controller can be connected to a DeviceNet or CC-Link network.

*1 Operates using network communications or serial communications.
 *2 Can make a direct connection to a field network with the network specifications.
 *3 Can be connected to a field network using a gateway unit.

Explanation of I/O Signal Functions

The table below explains the functions allocated to the controller's I/O signal.

Since the signals that can be used vary depending on the controller type and settings, check the signal table for each controller to confirm the available functions.

Signal Function Description

Classification	Signal abbreviations	Signal	Function description
Input	CSTR	Start signal	Input this signal to cause the actuator to start moving to the position set by the command position number signal.
	PC1 to PC256	Command position number signal	This signal is used to input a target position number (binary input).
	BKRL	Brake forced release signal	This signal forcibly releases the brake.
	RMOD	Running mode switching signal	This signal can switch the running mode when the MODE switch on the controller is set to AUTO. (AUTO when this signal is OFF, or MANU when the signal is ON).
	* STP	Pause signal (Note 1)	Turning this signal OFF causes the moving actuator to decelerate to a stop. The actuator will resume the remaining movement if the signal is turned ON during the pause.
	RES	Reset signal	Turning this signal ON resets the alarms that are present. If this signal is turned ON while the actuator is paused (*STP is OFF), the remaining movement can be cancelled.
	SON	Servo ON signal	The servo remains on while this signal is ON, or off while the signal is OFF.
	HOME	Home return signal	Turning this signal ON performs home-return operation.
	MODE	Teaching mode signal	Turning this signal ON switches the controller to teaching mode (provided that CSTR, JOG+ and JOG- are all OFF and the actuator is not moving).
	JISL	JOG/INJOG switching signal	When the main signal is off, the JOG operation will be conducted for JOG+ and JOG-. When the signal is on, the unit will do the inching operation for JOG+ and JOG-.
	JOG+, JOG-	JOG signal	When the JISL signal is off and the JOG +/- signal turns on, the unit will jog in the + (positive) direction when the JOG + turns on and the - (negative) direction when the JOG - turns on. During the JOG operation, the unit slows to a stop when the JOG +/- signal turns off.
	PWRT	Teaching signal	In the teaching mode, specify a desired position number and then turn this signal ON for at least 20ms to write the current position to the specified position number.
	ST0 to ST6	Start position command	Turning this signal ON in the solenoid valve mode causes the actuator to move to the specified position. (Start signal is not required)
	TL	Torque limit selection signal	While this signal is ON, torque is limited by the value set by a parameter. The TLR signal turns on if torque has reached the specified value. (Dedicated pulse train type)
	Output	DCLR	Deviation counter clear signal
PEND/INP		In position signal	This signal turns ON when the actuator has entered the positioning band after movement. If the actuator has exceeded the positioning band, PEND does not turn OFF, but INP does. PEND and INP can be swapped within parameters.
PM1 to PM256		Position complete signal	This signal is used to output the position number achieved at the completion of positioning (binary output)
HEND		Home return completion signal	This signal turns ON upon completion of home return.
ZONE1		Zone signal	This signal turns ON when the current actuator position has entered the range specified by the parameters.
PZONE		Positioning zone signal	Turns ON when actuator moves into a position within the range of the target position data that was set. PZONE can be used together with ZONE1, but PZONE is valid only during movement to a specified position.
RMDS		Running mode status signal	This outputs the operation mode status.
* ALM		Controller alarm status signal	This signal remains ON while the controller is not in the alarm condition, and turns OFF when an alarm has occurred.
MOVE		Moving signal	Turns ON while the actuator is moving (home return), including when there is push force.
SV		Servo ON status signal	This signal turns ON when servo is ON.
* EMGS		Emergency stop status signal	This signal remains ON while the controller is not in the emergency stop mode, and turns OFF once an emergency stop has been actuated.
MODES		Mode status signal	The mode signal input turns it ON when it goes into teaching mode. It turns OFF when it goes into normal mode.
WEND		Writing complete signal	This signal remains OFF after the controller has switched to the teaching mode. It turns ON upon completion of data write using the PWRT signal. If the PWRT signal is turned Off, this signal also turns OFF.
PE0 to PE6		Current position number signal	This signal turns ON after the controller has completed moving to the target position in the solenoid valve mode.
TLR		Torque limiting signal	This signal turns ON once the motor torque has reached the specified value in a condition where torque is being limited by the TL signal. (Dedicated pulse train type)
LSO to LS2	Limit switch output signal	Each signal turns ON when the current actuator position has entered the positioning band before or after the target position. If the actuator has already completed home return, these signals are output even before a movement command is issued or while the servo is OFF. (Dedicated Solenoid Valve Mode)	

(Note) Signals with asterisks (*) are normally ON and OFF during operation.

(Note 1) Please note that no pause can be made during an S-shaped acceleration/deceleration operation.

- Controller
- PMEC
AMEC
- PSEP
ASEP
DSEP
- MSEP
- ERC3
- ERC2
- PCON
-CA
- PCON
- ACON
- SCON
-CA
- MSCON
- PSEL
- ASEL
- SSEL
- XSEL
- PS-24
- Pulse Motor
- Servo Motor (24V)
- Servo Motor (200V)
- Linear Servo Motor

I/O Signal Table

■ Positioner type (ACON-C / CG)

Pin No.	Classification		Parameters (select PIO pattern)					
			0	1	2	3	4	5
			Positioning mode	Teaching mode	256-point mode	512-point mode	Solenoid Valve Mode 1	Solenoid Valve Mode 2
			Positioning Points	64 points	64 points	256 points	512 points	7 points
		Zone signal	○	×	×	×	○	○
		P-zone signal	○	○	○	×	○	○
1A	24V		P24					
2A	24V		P24					
3A	—		NC					
4A	—		NC					
5A	Input	IN0	PC1	PC1	PC1	PC1	ST0	ST0
6A		IN1	PC2	PC2	PC2	PC2	ST1	ST1 (JOG+)
7A		IN2	PC4	PC4	PC4	PC4	ST2	ST2 (-)
8A		IN3	PC8	PC8	PC8	PC8	ST3	—
9A		IN4	PC16	PC16	PC16	PC16	ST4	—
10A		IN5	PC32	PC32	PC32	PC32	ST5	—
11A		IN6	—	MODE	PC64	PC64	ST6	—
12A		IN7	—	JISL	PC128	PC128	—	—
13A		IN8	—	JOG+	—	PC256	—	—
14A		IN9	BKRL	JOG-	BKRL	BKRL	BKRL	BKRL
15A		IN10	RMOD	RMOD	RMOD	RMOD	RMOD	RMOD
16A		IN11	HOME	HOME	HOME	HOME	HOME	—
17A		IN12	* STP	* STP	* STP	* STP	* STP	—
18A		IN13	CSTR	CSTR/PWRT	CSTR	CSTR	—	—
19A		IN14	RES	RES	RES	RES	RES	RES
20A	IN15	SON	SON	SON	SON	SON	SON	
1B	Output	OUT0	PM1	PM1	PM1	PM1	PE0	LS0
2B		OUT1	PM2	PM2	PM2	PM2	PE1	LS1
3B		OUT2	PM4	PM4	PM4	PM4	PE2	LS2 (-)
4B		OUT3	PM8	PM8	PM8	PM8	PE3	—
5B		OUT4	PM16	PM16	PM16	PM16	PE4	—
6B		OUT5	PM32	PM32	PM32	PM32	PE5	—
7B		OUT6	MOVE	MOVE	PM64	PM64	PE6	—
8B		OUT7	ZONE1	MODES	PM128	PM128	ZONE1	ZONE1
9B		OUT8	PZONE	PZONE	PZONE	PM256	PZONE	PZONE
10B		OUT9	RMDS	RMDS	RMDS	RMDS	RMDS	RMDS
11B		OUT10	HEND	HEND	HEND	HEND	HEND	HEND
12B		OUT11	PEND	PEND/WEND	PEND	PEND	PEND	—
13B		OUT12	SV	SV	SV	SV	SV	SV
14B		OUT13	*EMGS	*EMGS	*EMGS	*EMGS	*EMGS	*EMGS
15B		OUT14	*ALM	*ALM	*ALM	*ALM	*ALM	*ALM
16B	OUT15	—	—	—	—	—	—	
17B	—		NC					
18B	—		NC					
19B	0V		N					
20B	0V		N					

(Note) The names of signals above inside () are functions before the unit returns home.
 (Note) Signals with asterisks (*) are normally ON, and OFF during operation.

■ Solenoid valve type (ACON-CY)

Pin No.	Classification		Parameters (select PIO pattern)	
			0	1
			Solenoid valve mode 0	Solenoid valve mode 1
			Positioning Points	3 points
		Zone signal	×	×
		P-zone signal	×	○
1	24V			
2	0V			
3	Input	IN0	ST0	ST0
4		IN1	ST1 (JOG+)	ST1 (JOG+)
5		IN2	ST2 (RES)	ST2 (RES)
6		IN3	SON	SON
7	Output	OUT0	LS0	PE0
8		OUT1	LS1	PE1
9		OUT2	LS2 (-)	PE2 (-)
10		OUT3	SV	PZONE
11		OUT4	HEND	HEND
12	OUT5	* ALM	* ALM	

(Note) The names of signals above inside () are functions before the unit returns home.
 (Note) Signals with asterisks (*) are normally ON, and OFF during operation.

■ Pulse Train Type (ACON-PL/PO)

Pin No.	Classification		Parameters (select PIO pattern)	
			0	1
			Standard mode	Push mode
			Positioning Points	—
		Zone signal	×	×
		P-zone signal	×	×
2	0V			
4	Input	IN0	SON	ON
		IN1	TL	TL
		IN2	HOME	HOME
6	Output	IN3	RES	RES / DCLR
		OUT0	SV	SV
		OUT1	INP	INP / TLR
		OUT2	HEND	HEND
10	Input	OUT3	* ALM	* ALM
			* PP	* PP
			PP	PP
12	Input		* NP	* NP
			NP	NP
14	Input			

(Note) Signals with asterisks (*) are normally ON, and OFF during operation.

Wiring Diagram for the Pulse-Train Type

■ Differential Line Driver Method (ACON-PL)

Max. input pulse frequency : Max. 200 kpps
Cable Length : Max. 10m

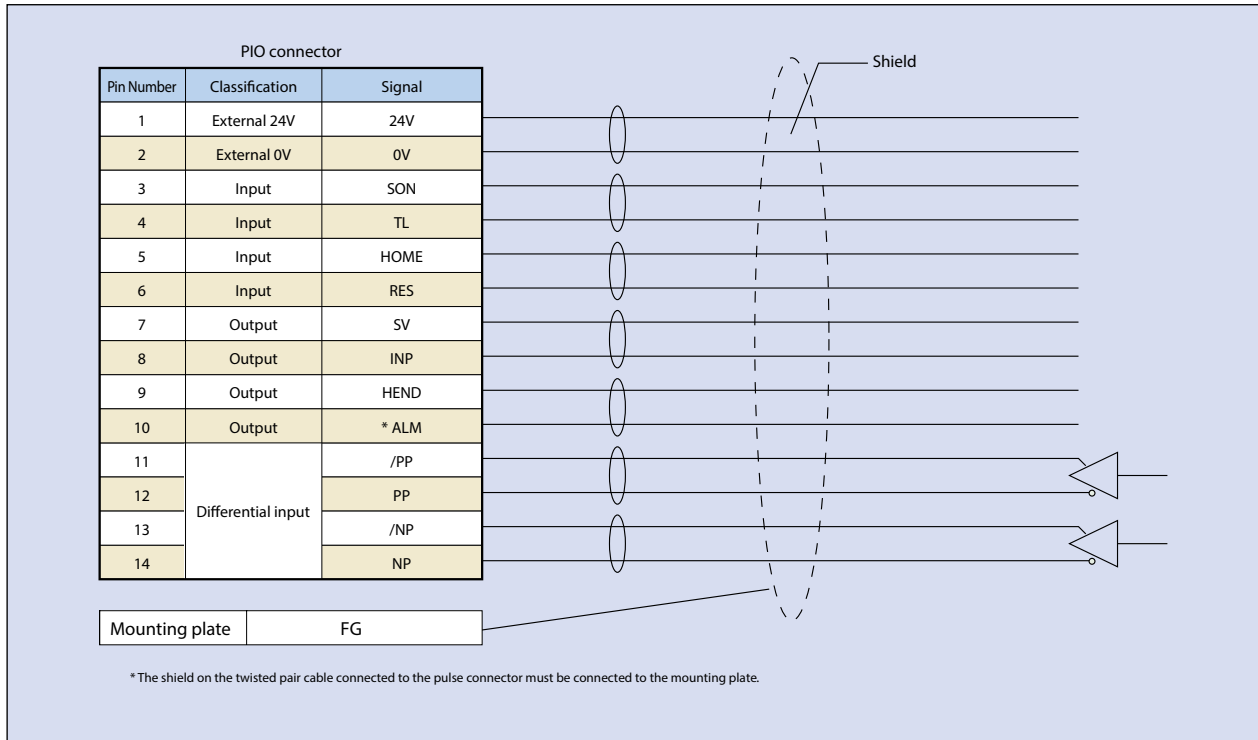

■ Open Collector Method (ACON-PO)

Max. input pulse frequency : Max. 60 kpps
Cable Length : Max. 2m

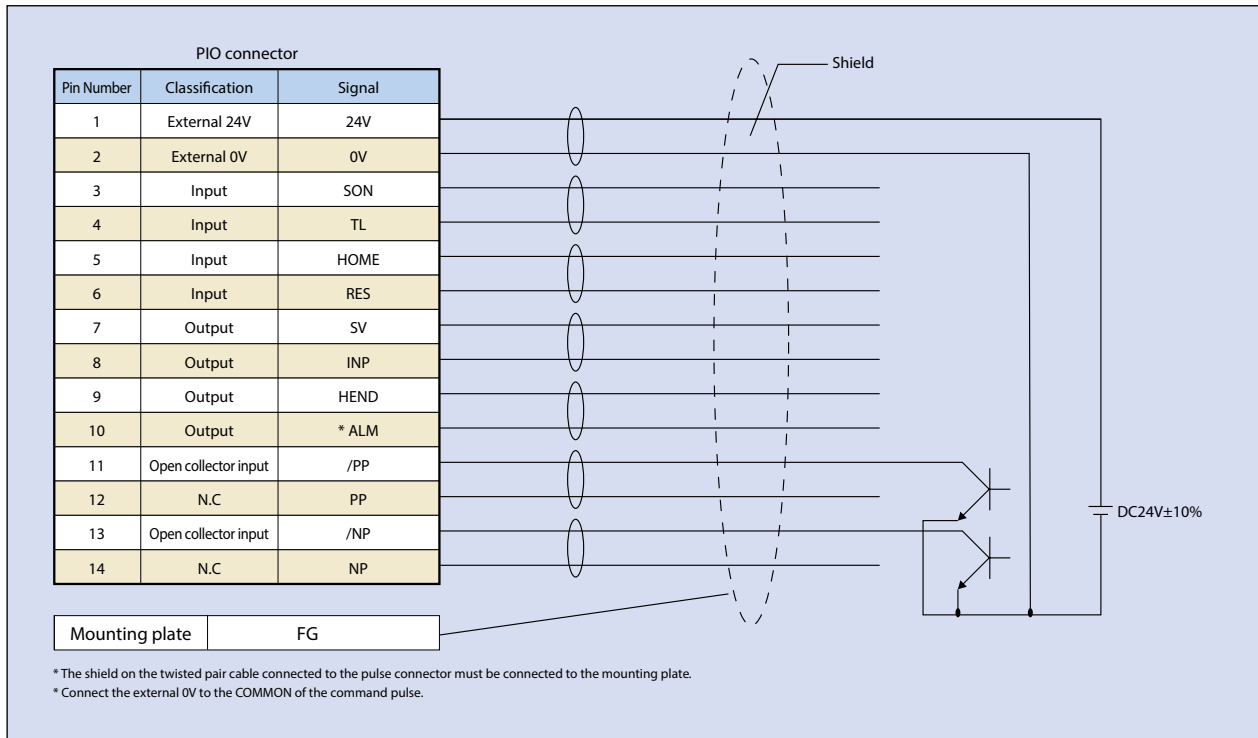

- Controller
- PMEC
AMEC
- PSEP
ASEP
DSEP
- MSEP
- ERC3
- ERC2
- PCON
-CA
- PCON
- ACON
- SCON
-CA
- MSCON
- PSEL
- ASEL
- SSEL
- XSEL
- PS-24
- Pulse Motor
- Servo Motor (24V)
- Servo Motor (200V)
- Linear Servo Motor

Command Pulse Input State

Command pulse train state		Input terminal	During forward operation	During reversed operation
Negative logic	Forward pulse train	PP-/PP		
	Reversed pulse train	NP-/NP		
	The forward pulse train causes the motor to rotate forward, and the reverse pulse train causes the motor to rotate in reverse.			
	Pulse train	PP-/PP		
	Symbols	NP-/NP	Low	High
	The command pulse is used for the amount of motor rotation, and the command symbol is used for rotational direction.			
Positive logic	A/B phase pulse train	PP-/PP		
		NP-/NP		
	An A/B phase pulse with a 90° phase difference (multiplier is 4) is used to generate commands for the amount of rotation and rotational direction.			
	Forward pulse train	PP-/PP		
	Reversed pulse train	NP-/NP		
	Symbols	NP-/NP	High	Low
	PP-/PP			
	NP-/NP			

* For the number of encoder pulse for the actuators operable with ACON, please refer to page Pre-41.

Table Of Specifications

Item	Specifications					
	C	CG	CY	PL	PO	SE
Controller type	C	CG	CY	PL	PO	SE
Connected actuator	RCA Series Actuator					
Number of control axes	1-axis					
Operating method	Positioner type		Solenoid valve type	Pulse train input type		Serial communication type
Positioning Points	512 points		3 points	—		64 points
Backup memory	EEPROM					
I/O connector	40-pin connector		12-pin connector	14-pin connector		None
Number of I/O	16 input points/16 output points		4 input points / 6 output points	4 input points/4 output points		None
I/O power	External supply DC24V±10%					
Serial Communication	RS485 1ch					
Peripheral device communication cable	CB-PAC-PIO□□□□		CB-PACY-PIO□□□□	CB-PACPU-PIO□□□□		CB-RCB-CTL002
Command pulse train input method	—			Differential line driver	Open collector	
Max. input pulse frequency (Note 1)	—			Max. 200 kpps	Max. 60 kpps	
Position detection method	Incremental encoder					
Drive-source cutoff relay at emergency stop	Integrated	External				
Forced release of electromagnetic brake	Brake release switch ON/OFF		ON/OFF terminal signal inside the power terminal for brake release			
Input Voltage	DC24V ± 10%					
Dielectric strength voltage	DC500V 1MΩ					
Vibration resistance	XYZ directions 10 to 57Hz, One side amplitude: 0.035mm (continuous), 0.075mm (intermittent) 58 to 150 Hz 4.9 m/s ² (continuous), 9.8 m/s ² (intermittent)					
Ambient operating temperature	0~40°C					
Ambient operating humidity	10 - 95% (non-condensing)					
Ambient operating atmosphere	Without corrosive gases					
Protection class	IP20					
Weight	Approx. 300g		Approx. 130g			

(Note 1) With the open collector specification, keep the maximum input frequency to 60 kpps or below to prevent malfunction. For applications exceeding 60kpps, use the differential line driver.

	Actuator	Motor	Standard specifications/high acceleration and deceleration model		Power-saving model		
			Rated [A]	Max. [A]	Rated [A]	Max. [A]	
Motor Power Supply Capacity (Note 2)	RCA	10W	1.3	4.4	1.3	2.5	
		20W [Model symbol: 20]	1.3	4.4	1.3	2.5	
		30W	1.3	4.4	1.3	2.2	
	RCA2	20W [Model symbol: 20S] SA4, RA3, TA5 Type dedicated	1.7	5.1	1.7	3.4	
		RCL	2W	0.8	4.6		
			5W	1.0	6.4		
10W	1.3	6.4					

(Note 2) Other than motor power supply capacity, increase 0.5A as control power supply. Inrush current of approx. 5 to 12 times the rated current occurs within 1 to 2 msec from turning the power on. The inrush current changes depending on the power supply line impedance.

External Dimensions

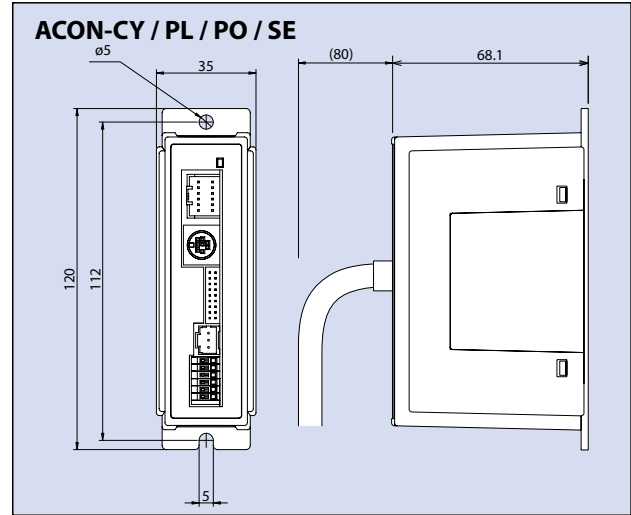
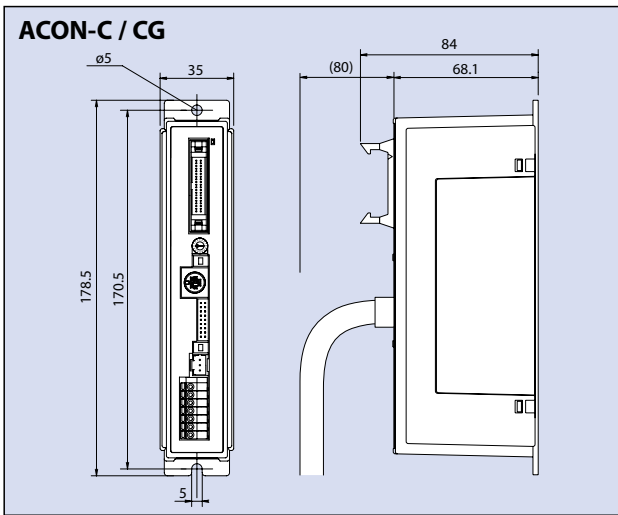

Name of each Part

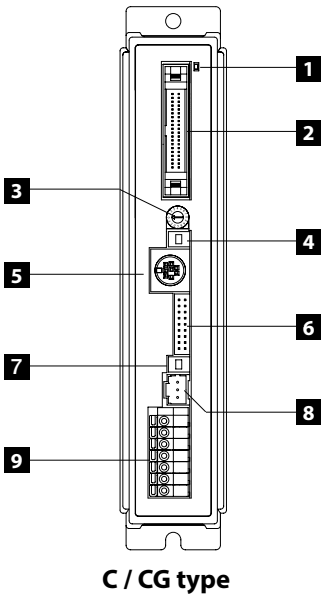

C / CG type

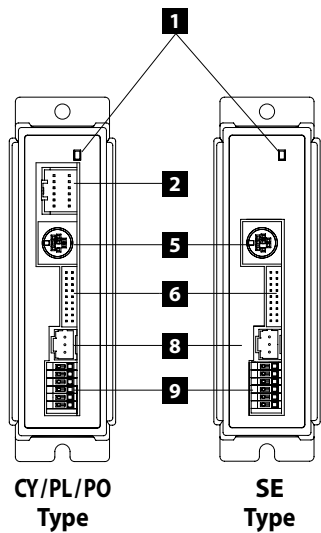

CY/PL/PO Type

SE Type

* PIO connectors are:
CY: 12 pin
PL/PO: 14 pin

1 LED display

These LED colors indicate the condition of the controller.
Lit (green) Servo ON Lit (red) Alarm activated Unlit Servo OFF Blinking (green) Automatic servo-OFF
Emergency stop

2 PIO connector

Connects a cable for communicating with a PLC or other external equipment.

3 Address-setting rotary switch

This switch sets the addresses for controllers used when the unit is linked with controllers.

4 Mode switch

Switches between manual teaching pendant operations (MANU) and automatic operations (AUTO).

Operation details

MANUAL	I/O commands are not accepted. Data can be written from a teaching pendant or PC.
AUTO	I/O commands are valid, while operations from a teaching pendant or PC are not accepted. However, monitoring is possible.

5 SIO connector

Connects a teaching pendant, PC cable, controller, or gateway unit to a controller.

Operation details

Pin No.	Signal	Name	Remarks
1	SGA	Positive side, RS485 differential signal	
2	SGB	Negative side, RS485 differential signal	
3	5V	+5V output	For RS232/485 conversion
4	ENBL	Enable signal	
5	EMGA	EMG line connection to external equipment	
6	24V	24-V power for T/P	For T/P
7	0V	GND	
8	EMGB	EMG line connection to external equipment	
9	0V	EMG line connection to external equipment ground	

6 Encoder brake connector

Connects the encoder/brake cable for the actuator.

7 Brake release switch

This switch forces the brake to release.

8 Motor connector

Connects the motor cable for the actuator.

9 Power terminal block

Main power for controller(s), emergency stop

C / CG type

Terminal number	Signal	Name
7	S1	External drive-source cutoff for TP_EMG terminal
6	S2	TP_EMG terminal
5	MPI	Motor drive-source cutoff terminal
4	MPO	Motor drive-source cutoff terminal
3	24V	Positive side of the 24-V power supply
2	0V	Negative side of the 24-V power supply
1	EMG	EMG signal (application of 24 V)

CY / PL / PO / SE type

Terminal number	Signal	Name
6	BK	BK release
5	MPI	Motor drive-source cutoff terminal
4	MPO	Motor drive-source cutoff terminal
3	24V	Positive side of the 24-V power supply
2	0V	Negative side of the 24-V power supply
1	EMG	EMG signal (application of 24 V)

Options

Teaching pendant

- Summary Teaching device for positioning input, test operation, and monitoring.
- Model **CON-PTA-C** (Touch panel teaching pendant)
CON-T (Standard type)
- Setting

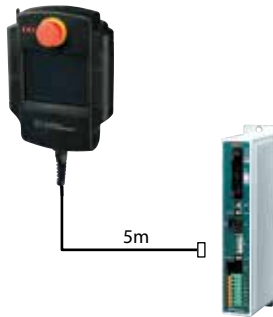
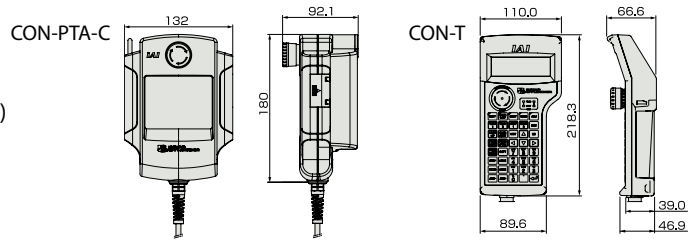

Specification

Item		Content	
Model	English Version	CON-PTA-C-ENG	CON-T-ENG
Data Input		○	○
Actuator Motion		○	○
Ambient Operating Temp./Humidity		Temp 0~40°C; 85% RH or below	
Ambient Operating Atmosphere		No corrosive gases. Especially no dust.	
Protective class		IP40	IP54
Weight		Approx. 570g	Approx. 400g
Cable Length		5m	
Display		65,536 color (16 bit color) White LED back light	20 char. x 4 lines LCD display
Standard Price		—	—

PC software (Windows only)

- Summary A startup support software for inputting positions, performing test runs, and monitoring. With enhancements for adjustment functions, the startup time is shortened.

Supported Windows OS:
2000 SP4 or later / XP SP2 or later / Vista / 7

- Model **RCM-101-MW** (External device communication cable + RS232 conversion unit)

Setting

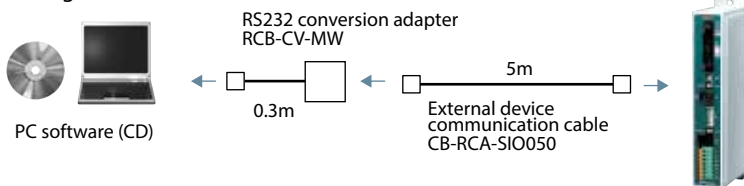

- Model **RCM-101-USB** (External device communication cable + USB converter adaptor + USB cable)

Setting

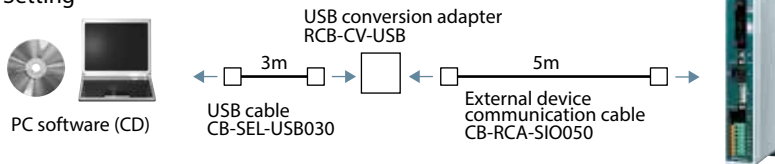

Spare Parts

When you need spare parts after purchasing the product, such as when replacing a cable, refer to the list of models below.

Motor Cable for RCA

Model **CB-ACS-MA**

* Enter the cable length (L) into . Compatible to a maximum of 20 meters.
Ex.: 080 = 8m

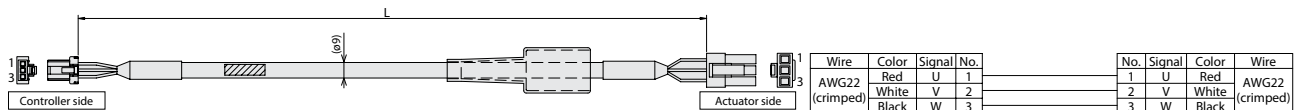

Min. bend radius $r = 50\text{mm}$ or larger (when movable type is used)

639

ACON

Encoder Cable / Encoder Robot Cable for RCA

Model **CB-ACS-PA** □□□/□□□**CB-ACS-PA** □□□**-RB** *The standard cable for the encoder cable is the normal cable. A robot cable can be specified as an option. *Enter the cable length (L) into □□□□. Compatible to a maximum of 20 meters. Ex.: 080 = 8m

Min. bend radius r = 50 mm or larger (when movable type is used)
* Only robot cable is to be used in a cable track.

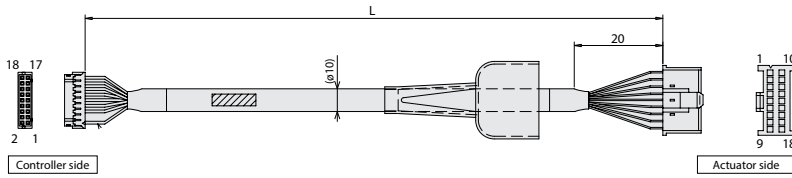

CN2			CN1		
Cable color	Signal	Pin No.	Pin No.	Signal	Cable color
White/Purple	Blue	LS+ 18	1	ENA	Gray
White/Gray	Orange	LS- 17	2	ENA	Red
Yellow	Green	BK+ 16	3	ENB	Black
Blue	Brown	BK- 15	4	ENB	Yellow
White/Blue	Gray	ENA 14	5	-	-
White/Yellow	Red	ENA 13	6	-	-
White/Red	Black	ENB 12	7	LS+	Blue
White/Black	Yellow	ENB 11	8	-	-
Orange	Pink	ENZ 10	9	FG	Ground
Green	Purple	ENZ 9	10	ENZ	Pink
Purple	White	- 8	11	ENZ	Purple
Gray	Blue/red	VPS 7	12	-	White
Red	Orange/White	SV 6	13	VPS	Blue/red
Black	Green/White	GND 5	14	SV	Orange/White
-	-	- 4	15	GND	Green/White
-	-	- 3	16	LS-	Orange
-	-	- 2	17	BK-	Brown
Ground	Ground	FG 1	18	BK+	Green

Housing : PHDR-18VR (JST)
Contact : SPHD-001T-P0.5 (JST)

Plug housing : XMP-18V (JST)
Socket contact : BXA-001T-P0.6 (JST)
Retainer : XMS-09V (JST)

Motor-Encoder Integrated Robot Cable for RCA2 * The standard cable is a robot cable.

Model **CB-ACS-MPA** □□□ *Enter the cable length (L) into □□□□. Compatible to a maximum of 20 meters. Ex.: 080 = 8m

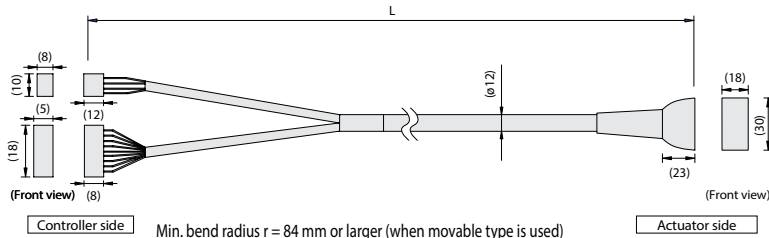

Signal	Pin No.	Wire color	Pin No.	Signal
U	1	Red	A1	U
V	2	Yellow	B1	V
W	3	Black	A2	W
			B2	NC
			A3	NC
			B3	NC
BK+	16	Yellow (Red ●)	A4	BK+
BK-	15	Yellow (Blue ●)	B4	BK-
LS+	18	Pink (Red ●)	A5	LS+
LS-	17	Pink (Blue ●)	B5	LS-
A+	14	White (Red ●)	A6	A+
A-	13	White (Blue ●)	B6	A-
B+	12	Orange (Red ●)	A7	B+
B-	11	Orange (Blue ●)	B7	B-
Z+	10	Gray (Red ●)	A8	Z+
Z-	9	Gray (Blue ●)	B8	Z-
/PS	8	Orange (Red ● Consecutive)	A9	/PS
VCC	6	Orange (Blue ● Consecutive)	B9	VCC
GND	5	Gray (Red ● Consecutive)	A10	VCC
NC	1	Gray (Blue ● Consecutive)	B10	GND
FG	1		A11	NC
			B11	FG

I/O Flat Cable (for ACON-C / CG)

Model **CB-PAC-PIO** □□□ *Enter the cable length (L) into □□□□. Compatible to a maximum of 10 meters. Ex.: 080 = 8m

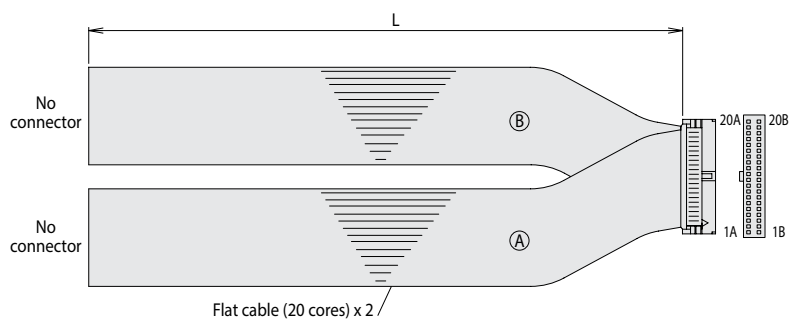

No.	Signal name	Cable color	Wiring	No.	Signal name	Cable color	Wiring
1A	24V	Brown - 1	Flat cable (20 cores) x 2 Flat cable (20 cores) x 2 (crimped)	18	OUT0	Brown - 3	Flat cable (20 cores) x 2 (crimped) AWG 28
2A	24V	Red - 1		2B	OUT1	Red - 3	
3A	-	Orange - 1		3B	OUT2	Orange - 3	
4A	-	Yellow - 1		4B	OUT3	Yellow - 3	
5A	IN0	Green - 1		5B	OUT4	Green - 3	
6A	IN1	Blue - 1		6B	OUT5	Blue - 3	
7A	IN2	Purple - 1		7B	OUT6	Purple - 3	
8A	IN3	Gray - 1		8B	OUT7	Gray - 3	
9A	IN4	White - 1		9B	OUT8	White - 3	
10A	IN5	Black - 1		10B	OUT9	Black - 3	
11A	IN6	Brown - 2		11B	OUT10	Brown - 4	
12A	IN7	Red - 2		12B	OUT11	Red - 4	
13A	IN8	Orange - 2		13B	OUT12	Orange - 4	
14A	IN9	Yellow - 2		14B	OUT13	Yellow - 4	
15A	IN10	Green - 2		15B	OUT14	Green - 4	
16A	IN11	Blue - 2		16B	OUT15	Blue - 4	
17A	IN12	Purple - 2		17B	-	Purple - 4	
18A	IN13	Gray - 2		18B	-	Gray - 4	
19A	IN14	White - 2		19B	0V	White - 4	
20A	IN15	Black - 2		20B	0V	Black - 4	

Solenoid Valve Type I/O Cable (for ACON-CY)

Model **CB-PACY-PIO** □□□ *Enter the cable length (L) into □□□□. Compatible to a maximum of 10 meters. Ex.: 080 = 8m

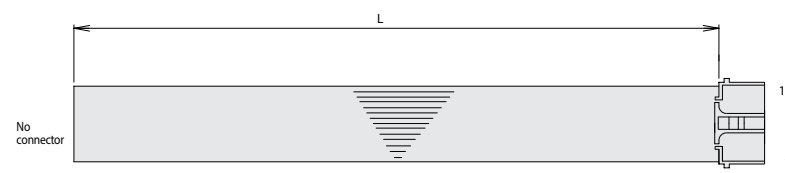

No.	Signal	Cable Color	Wire
1	24V	Brown-1	Flat cable (crimped) AWG28
2	0V	Red-1	
3	IN0	Orange-1	
4	IN1	Yellow-1	
5	IN2	Green-1	
6	IN3	Blue-1	
7	OUT0	Purple-1	
8	OUT1	Gray-1	
9	OUT2	White-1	
10	OUT3	Black-1	
11	OUT4	Brown-2	
12	OUT5	Red-2	

Pulse Train Control I/O Cable (for ACON-PL/PO)

Model **CB-PACPU-PIO** □□□ *Enter the cable length (L) into □□□□. Compatible to a maximum of 10 meters. Ex.: 080 = 8m

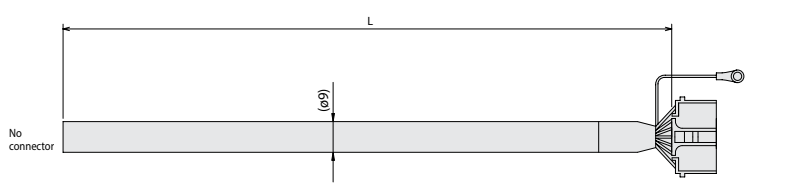

No.	Signal	Cable Color	Wire
1	IO 24V	Black	0.2sq
2	IO 24G	White/Black	
3	IN0	Red	
4	IN1	White/Red	
5	IN2	Green	
6	IN3	White/Green	
7	OUT0	Yellow	
8	OUT1	White/Yellow	
9	OUT2	Brown	
10	OUT3	White/Brown	
11	PG	Blue	
12	PG	White/Blue	
13	NP	Gray	
14	NG	White/Gray	

0.5-5 (JST)
1 FG [White/Gray] AWG24

- Controller
- PMEC
AMEC
- PSEP
ASEP
DSEP
- MSEP
- ERC3
- ERC2
- PCON
-CA
- PCON
- ACON
- SCON
-CA
- MSCON
- PSEL
- ASEL
- SSEL
- XSEL
- PS-24

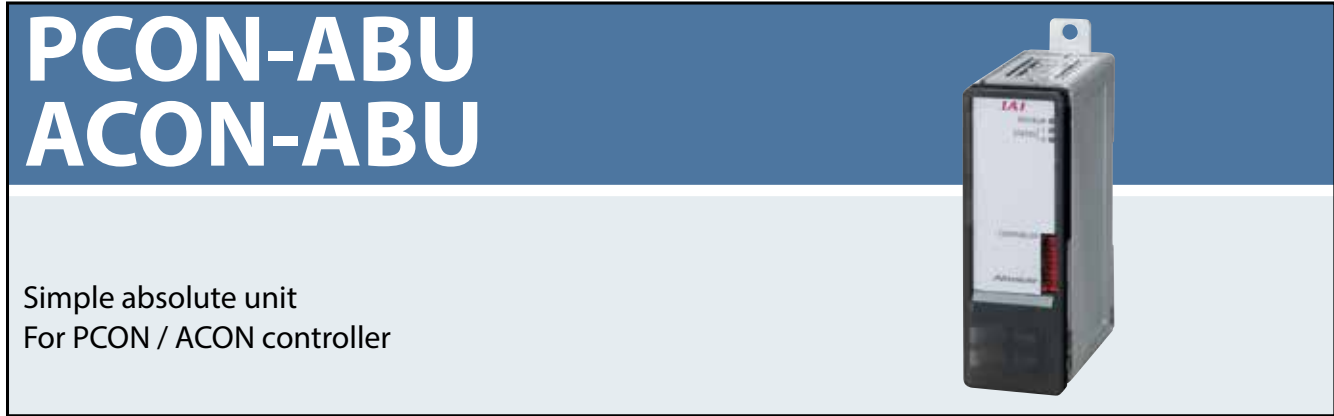

Simple absolute unit
For PCON / ACON controller

Features

1 When attached to a ACON/PCON-C, -CG, -CY, or -SE (incremental) controller, the data from the encoder is retained even after the controller's main power has been turned OFF, allowing you to use it as an absolute model, which does not require homing at power-up.
* Cannot be used for ACON/PCON-PL or PO types, PCON-CA/CFA types.

Caution The encoder type for the actuators and controllers with a simple absolute unit is "I" (incremental) and not "A" (absolute).

2 Having the same size as the CY and SE compact controllers 34mm (W) × 100mm (H) × 75.3mm (D), it can be installed in a small space.

3 Encoder data can be retained up to 20 days.

Caution An error will occur if the actuator's slider or rod is moved faster than the fixed speed, while the encoder data is retained. Check the specifications table on page 642 for the allowable speed (rotations).

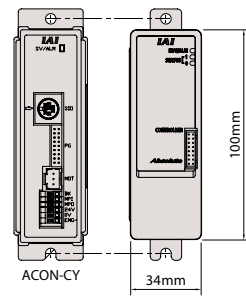
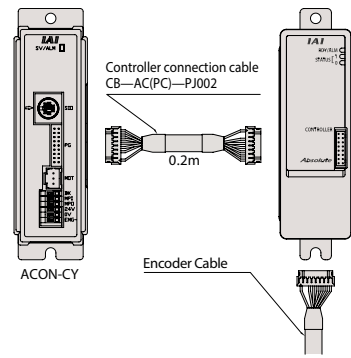

Models

	PCON controller	ACON controller
Model	PCON-ABU	ACON-ABU
Standard Price	—	—

Connectable Actuators

The simple absolute unit is available for the following actuators. (Models other than following models are not available.)

Corresponding series	Reference
RCP3 series	Corresponding to all models
RCP2 series	Corresponding to all models other than HS8C/HS8R/RA10C.
RCP2CR series	Corresponding to all models other than HS8C.
RCP2W series	Corresponding to all models other than SA16C/RA10C.
RCA2 series	Corresponding to all models
RCA series	Corresponding to all models
RCACR series	Corresponding to all models
RCAW series	Corresponding to all models

- Pulse Motor
- Servo Motor (24V)
- Servo Motor (200V)
- Linear Servo Motor

Specifications

Item	Details			
Model	ACON-ABU		PCON-ABU	
Connecting controller	ACON-C / CG / CY / SE		PCON-C / CG / CY / SE	
Connecting actuator	RCA2 / RCA series		RCP3/RCP2 series (* 1)	
Controller connection cable (included accessory)	Model CB-AC-PJ002 (0.2m)		Model CB-PC-PJ002 (0.2m)	
Simple absolute unit	Model ABU			
Backup battery (included accessory)	Model AB-7 (Ni-MH battery / Life: approx. 3 years)			
Power supply voltage	DC24V±10%			
Power supply current	Max. 300mA			
Ambient operating temperature	0 to 40°C (approx. 20°C is preferred)			
Ambient operating humidity	95% RH or lower (non-condensing)			
Ambient operating atmosphere	Without corrosive gases, without dust			
Weight	330g			

Allowable encoder RPM during data retention (*2)	800rpm	400rpm	200rpm	100rpm
Position data retaining time (*2)	120h	240h	360h	480h

(*1) Cannot be used with RCP2-RA10C/HS8C/HS8R/RCP2W-SA16C.

(*2) Position data retention time changes with the allowable encoder RPMs during data retention.
(800rpm→120h / 400rpm→240h / 200rpm→360h / 100rpm→480h)

External Dimension

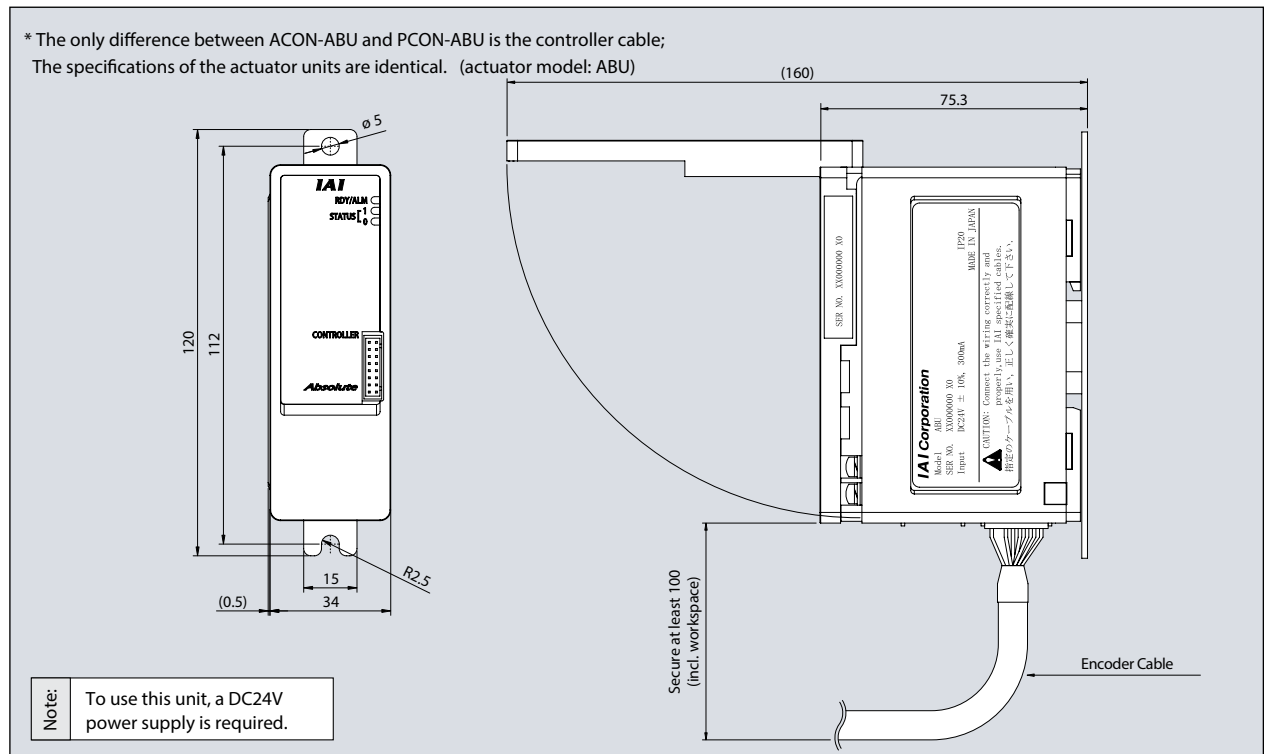

Controller

PMEC
AMECPSEP
ASEP
DSEP

MSEP

ERC3

ERC2

PCON
-CA

PCON

ACON

SCON
-CA

MSCON

PSEL

ASEL

SSEL

XSEL

PS-24

Pulse
MotorServo
Motor
(24V)Servo
Motor
(200V)Linear
Servo
Motor

- Controller
- PMEC
AMEC
- PSEP
ASEP
DSEP
- MSEP
- ERC3
- ERC2
- PCON
-CA
- PCON
- ACON
- SCON
-CA
- MSCON
- PSEL
- ASEL
- SSEL
- XSEL
- PS-24
- Pulse Motor
- Servo Motor (24V)
- Servo Motor (200V)
- Linear Servo Motor



RCS2/RCS3/Cartesian Robot/
Linear Servo Actuator Position Controller

Feature

1 Supporting major field networks <Optional function>

Direct connection is now possible not only to DeviceNet, CC-Link (*1) and PROFIBUS-DP, but also to MECHATROLINK, CompoNet, EtherCAT and EtherNet/IP. The actuator can also be operated by specifying coordinate values directly via a field network.
(*1) CC-Link was changed from remote I/O to remote device.



2 Vibration control function <Standard function>

A vibration control function has been added that suppresses vibration of the work part installed on the slider when the actuator's slider moves. This function shortens the time the actuator waits for vibration to settle, and consequently shortens the cycle time.

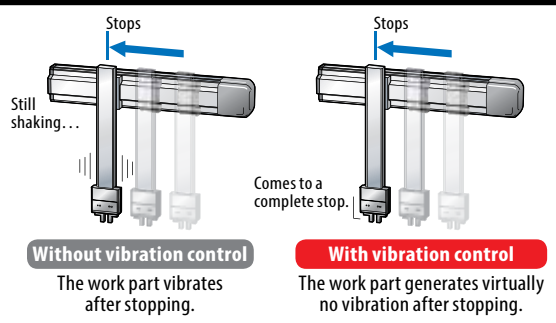

3 Increasing the actuator's load capacity with offboard tuning

Offboard tuning is a function to increase the acceleration/deceleration when the load mass is small, or decrease the acceleration/deceleration when the load mass is large, so that the actuator is set to operate optimally for the given load mass. Also, servo tuning would be done at the same time. (See page A-98 for the details.)

4 Checking when to maintain based on the total number of movements and total distance travelled <Standard function>

The total number of actuator movements and the total distance travelled are calculated and recorded in the controller, and when the predetermined count or distance is exceeded, a signal is output to an external device. You can use this function to check when the actuator needs re-greasing or periodic inspection.

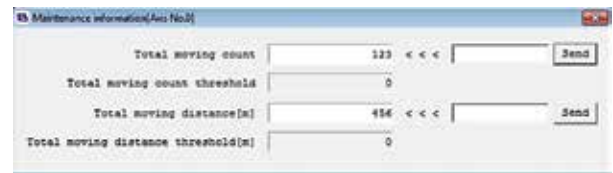

5 Keeping the alarm generation times with the calendar function <Standard function>

The clock function has been added to facilitate the analysis of the alarms because the time and date of each alarm that has occurred is now shown on the alarm history screen. (The time and date data is retained for 10 days.)

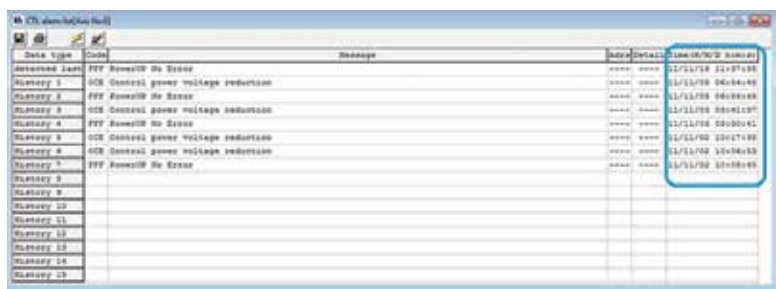

List of Models

Model		SCON-CA								
External view										
I/O type		Standard specification		Network connection specification (optional) (*2)						
I/O type specification		PIO connection specification (*1)		DeviceNet	CC-Link	PROFIBUS-DP	CompoNet	MECHATROLINK	EtherCAT	EtherNet/IP
I/O type code		NP/PN		DV	CC	PR	CN	ML	EC	EP
Applicable encoder type		Incremental	Absolute	Incremental/Absolute						
Standard price	20~150W	—	—	—	—	—	—	—	—	—
	200W	—	—							
	300~400W	—	—							
	600W	—	—							
	750W	—	—							
	750W (for force control)	—	—							

(*1) If the controller is operated in the pulse-train mode, only an incremental encoder can be used.
 (*2)The network connection specification type will not be able to operate with the PIO or Pulse train mode.

Model

SCON - CA

Series: CA High-function type

Type: High-function type

Motor type: 12, 20, 30D, 30R, 60, 100, 100S, 150

Encoder type: I Incremental, A Absolute, G Quasi-absolute

Option: HA High-acceleration/ deceleration specification

I/O type: NP, PN, DV, CC, PR, CN, ML, EC, EP

I/O cable length: 0, 2, 3, 5

Power supply voltage: 1 Single phase 100VAC, 2 Single phase 200VAC

* The high acceleration/deceleration specification can only be selected when the actuator is the high acceleration/deceleration type.
 <Actuators for high acceleration/deceleration>
 RCS2-SA4C/SA5C/SA6C/SA7C/RA4C/RA5C/
 RGS4C/RGS5C/RGD4C/RGD5C

* The quasi-absolute is for the LSAS series.

* If "DV","CC","PR","CN","ML," "EC" or "EP" is selected for the I/O type, select "0" for the I/O cable length.

12	12W motor	200	200W motor
20	20W motor	200S	For LSA-S10H/N15 LSAS-N15
30D	30W motor (for RCS2)	300S	For LSA-N19
30R	30W motor (for RS)	400	400W motor
60	60W motor	600	600W motor
100	100W motor	750	750W motor
100S	For LSA-N10 LSAS-N10	750S	For 750W actuator with load cell
150	150W motor		

System Configuration

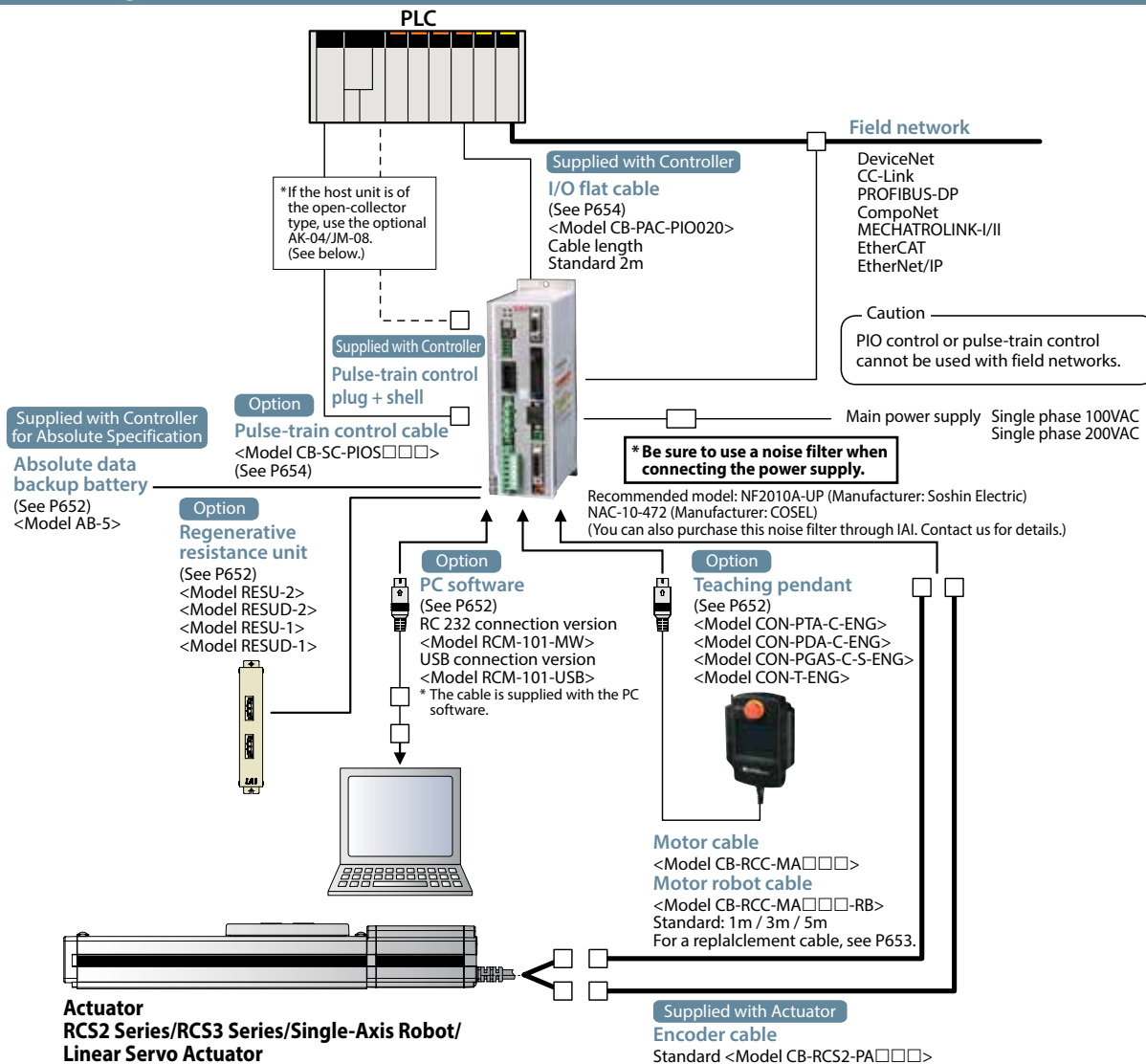

Pulse Converter: AK-04

Open-collector command pulses are converted to differential command pulses. Use this converter if the host controller outputs open-collector pulses.

Specification

Item	Specification
Input power	24 VDC±10% (Max. 50mA)
Input pulse	Open-collector (Collector current: 12mA max.)
Input frequency	200kHz or less
Output pulse	Differential output (10mA max.) (26C31 or equivalent)
Mass	10g or less (excluding cable connectors)
Accessories	37104-3122-000L (e-CON connector) x 2 Applicable wire: AWG Nos. 24 to 26

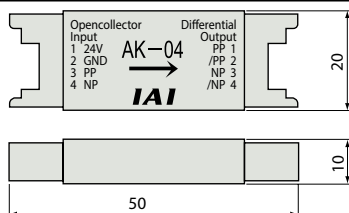

Pulse Converter: JM-08

Difference feedback pulses are converted to open-collector feedback pulses. Use this converter if the host controller inputs open-collector pulses.

Specification

Item	Specification
Input power	24 VDC±10% (Max. 50mA)
Input pulse	Differential input (10 mA max.) (conforming to RS422)
Input frequency	500kHz or less
Output pulse	24-VDC open-collector (Collector current: 25mA max.)
Mass	10g or less (excluding cable connectors)
Accessories	37104-3122-000FL (e-CON connector) x 2 Applicable wire: AWG Nos. 24 to 26

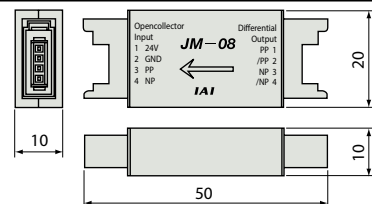

645

SCON-CA

Operation Modes

With this controller, you can select a desired control method from the two modes of positioner mode and pulse-train control mode. In the positioner mode, you can enter position data (target position, speed, acceleration, etc.) in the controller under the desired numbers and then specify each number externally via an I/O (input/output signal) to operate the actuator. Also, in the positioner mode, you can select the desired operation mode from the eight modes using the parameter. In the pulse-train control mode, you can control the travel, speed, acceleration, etc., by sending pulses from an external pulse generator.

Mode		Number of positioning points	Features
Positioner mode	Positioning mode	64 points	Standard factory-set mode. Specify externally a number corresponding to the position you want to move to, to operate the actuator.
	Teaching mode	64 points	In this mode, you can move the slider (rod) via an external signal and register the stopped position in the position data table.
	256-point mode	256 points	In this mode, the number of positioning points available in the positioning mode has been increased to 256 points.
	512-point mode	512 points	In this mode, the number of positioning points available in the positioning mode has been increased to 512 points.
	Solenoid valve mode 1	7 points	In this mode, the actuator can be moved only by turning signals ON/OFF, just like you do with an air cylinder of solenoid valve type.
	Solenoid valve mode 2	3 points	In this mode, the output signal is set to the same as the air cylinder auto switch in the solenoid valve mode.
	Force mode 1	32 points	In this mode, you can move to positions under force control in the positioning mode. (Up to 32 positioning points are available.)
	Force mode 2	5 points	In this mode, you can move to positions under force control in the solenoid valve mode. (Up to five positioning points are available.)
Pulse-train control mode		—	There is no need to enter position data in the controller, and the customer can operate the actuator freely based on custom control.

I/O Signal Table * You can select one of nine types of I/O signal assignments.

Pin No.	Category	Positioning point	Parameter (PIO pattern) selection								Pulse-train mode
			0	1	2	3	4	5	6	7	0
			Positioning mode	Teaching mode	256-point mode	512-point mode	Solenoid valve mode 1	Solenoid valve mode 2	Force mode 1	Force mode 2	Standard mode
1A	24V		64 points	64 points	256 points	512 points	7 points	3 points	32 points	5 points	—
2A	24V										P24
3A	—										P24
4A	—										NC
5A		IN0	PC1	PC1	PC1	PC1	ST0	ST0	PC1	ST0	SON
6A		IN1	PC2	PC2	PC2	PC2	ST1	ST1(JOG+)	PC2	ST1	RES
7A		IN2	PC4	PC4	PC4	PC4	ST2	ST2(-)	PC4	ST2	HOME
8A		IN3	PC8	PC8	PC8	PC8	ST3	—	PC8	ST3	TL
9A		IN4	PC16	PC16	PC16	PC16	ST4	—	PC16	ST4	CSTP
10A		IN5	PC32	PC32	PC32	PC32	ST5	—	—	—	DCLR
11A		IN6	—	MODE	PC64	PC64	ST6	—	—	—	BKRL
12A		IN7	—	JISL	PC128	PC128	—	—	—	—	RMOD
13A		IN8	—	JOG+	—	PC256	—	—	CLBR	CLBR	—
14A		IN9	BKRL	JOG-	BKRL	BKRL	BKRL	BKRL	BKRL	BKRL	—
15A		IN10	RMOD	RMOD	RMOD	RMOD	RMOD	RMOD	RMOD	RMOD	—
16A		IN11	HOME	HOME	HOME	HOME	HOME	—	HOME	HOME	—
17A		IN12	*STP	*STP	*STP	*STP	*STP	—	*STP	*STP	—
18A		IN13	CSTR	CSTR/PWRT	CSTR	CSTR	—	—	CSTR	—	—
19A		IN14	RES	RES	RES	RES	RES	RES	RES	RES	—
20A		IN15	SON	SON	SON	SON	SON	SON	SON	SON	—
1B		OUT0	PM1	PM1	PM1	PM1	PE0	LS0	PM1	PE0	PWR
2B		OUT1	PM2	PM2	PM2	PM2	PE1	LS1(TRQS)	PM2	PE1	SV
3B		OUT2	PM4	PM4	PM4	PM4	PE2	LS2(-)	PM4	PE2	INP
4B		OUT3	PM8	PM8	PM8	PM8	PE3	—	PM8	PE3	HEND
5B		OUT4	PM16	PM16	PM16	PM16	PE4	—	PM16	PE4	TLR
6B		OUT5	PM32	PM32	PM32	PM32	PE5	—	TRQS	TRQS	*ALM
7B		OUT6	MOVE	MOVE	PM64	PM64	PE6	—	LOAD	LOAD	*EMGS
8B		OUT7	ZONE1	MODES	PM128	PM128	ZONE1	ZONE1	CEND	CEND	RMDS
9B		OUT8	PZONE/ZONE2	PZONE/ZONE1	PZONE/ZONE1	PM256	PZONE/ZONE2	PZONE/ZONE2	PZONE/ZONE1	PZONE/ZONE1	ALM1
10B		OUT9	RMDS	RMDS	RMDS	RMDS	RMDS	RMDS	RMDS	RMDS	ALM2
11B		OUT10	HEND	HEND	HEND	HEND	HEND	HEND	HEND	HEND	ALM4
12B		OUT11	PEND	PEND/WEND	PEND	PEND	PEND	—	PEND	PEND	ALM8
13B		OUT12	SV	SV	SV	SV	SV	SV	SV	SV	*OVLW/*ALML
14B		OUT13	*EMGS	*EMGS	*EMGS	*EMGS	*EMGS	*EMGS	*EMGS	*EMGS	—
15B		OUT14	*ALM	*ALM	*ALM	*ALM	*ALM	*ALM	*ALM	*ALM	ZONE1
16B		OUT15	*BALM	*BALM	*BALM	*BALM	*BALM	*BALM	*BALM	*BALM	ZONE2
17B	—										—
18B	—										—
19B	0V						N				N
20B	0V						N				N

* In the above table, signals in () represent functions available before the home return.
 * In the above table, signals preceded by * are turned OFF while the actuator is operating.

Explanation of the I/O Signal Functions

The table below explains the functions assigned to the controller's I/O signals. The available signals vary depending on the controller type and settings, so use the signal table of each controller to check the functions available with that controller.

Category	Signal abbreviation	Signal name	Description of function
Input	CSTR	PTP strobe (start signal)	The actuator starts moving to the position set by the command position.
	PC1~PC256	Command position number	The position number of the target position is input (binary input).
	BKRL	Forced brake release	The brake is forcibly released.
	RMOD	Operation mode switching	The operation mode can be switched when the MODE switch on the controller is in the AUTO position. (The switch position is AUTO when this signal is OFF, or MANU when the signal is ON.)
	*STP	Pause	The actuator will decelerate to a stop when this signal turns OFF while the actuator is moving. The remaining movement will be suspended while the actuator is stopped and the movement will resume once the signal turns ON.
	RES	Reset	The alarm will be reset when the signal turns ON. The remaining travel can be cancelled by turning this signal ON while the actuator is paused (*STP is OFF).
	SON	Servo ON	The servo is ON while this signal is ON, and remains OFF while this signal is OFF.
	HOME	Home return	When this signal turns ON, the actuator performs home return operation.
	MODE	Teaching mode	When this signal turns ON, the actuator switches to the teaching mode. (Switching will not occur if CSTR, JOG+ and JOG- are all OFF and the actuator is still moving.)
	JISL	Jog/inch switching	When this signal turns OFF, the actuator can be jogged with JOG+ and JOG-. When the signal is ON, the actuator can be inched with JOG+ and JOG-.
	JOG+, JOG-	Jog	When the JISL signal is OFF, the actuator starts jogging in + or - direction upon detection of the ON edge of this signal. If the OFF edge of this signal is detected during jogging, the actuator decelerates to a stop.
	PWRT	Current position write	In the teaching mode, specify a position and then turn this signal ON for at least 20ms, and the current position will be written to the specified position.
	ST0~ST6	Start signal	In the solenoid valve mode, the actuator moves to the specified position when this signal turns ON. (The start signal is not required.)
	CLBR	Load cell calibration command	Load cell calibration starts when this signal has remained ON for at least 20ms.
	TL	Torque limit selection signal	While this signal is ON, torque is limited by the value set by a parameter. The TLR signal turns on if torque has reached the specified value.
	CSTP	Compulsory stop	Turning it ON continuously for more than 10ms compulsorily stops the actuator. The actuator decelerates then stops with the torque set in the controller and then turns the servo OFF.
	DCLR	Deviation counter clear signal	The position deviation counter is continuously cleared while this signal is ON.
Output	PEND/INP	Positioning complete	This signal turns ON when the actuator enters the in-position band after movement. If the actuator exceeds the in-position band, the PEND signal does not turn OFF, but the INP signal turns OFF. PEND and INP can be switched using a parameter.
	PM1~PM256	Complete position number	The position number of the position reached at the end of positioning is output (binary output).
	HEND	Home return completion	This signal turns ON upon completion of home return.
	ZONE1/ZONE2	Zone	This signal turns ON if the current actuator position is within the range set by the parameter.
	PZONE	Position zone	This signal turns ON when the current actuator position enters the range set in the position data table after position movement. This signal can be used with ZONE1, but PZONE becomes effective only when moving to a specified position.
	RMD5	Operation mode status output	The operation mode status is output. This signal turns ON when the controller is in the manual mode.
	*OVLW	Overload warning	This signal is ON in a normal condition, and turns OFF when the overload warning level is exceeded. (Operation will continue.)
	*ALML	Minor failure alarm	This signal is ON in a normal condition, and turns OFF when a message-level alarm occurs. (Operation will continue.)
	*ALM	Alarm	This signal is ON when the controller is in a normal condition, and turns OFF when an alarm occurs.
	MOVE	Moving	This signal is ON while the actuator is moving (also during home return and push-motion operation).
	SV	Servo ON	This signal is ON while the servo is ON.
	*EMGS	Emergency stop output	This signal is ON when no emergency stop is actuated on the controller, and turns OFF when an emergency stop is actuated.
	*BALM	Absolute battery voltage low warning	If the controller is of the absolute specification, this signal turns OFF when the voltage of the absolute battery drops. (Operation will continue.)
	MODES	Teaching mode output	This signal turns ON when the actuator enters the teaching mode via MODE signal input. It turns OFF once the actuator returns to the normal mode.
	WEND	Write complete	This signal is OFF immediately after switching to the teaching mode, and turns ON once writing is completed according to the PWRT signal. When the PWRT signal turns OFF, this signal also turns OFF.
	PE0~PE6	Current position number	This signal turns ON when the actuator has completed moving to the target position in the solenoid valve mode.
	CEND	Load cell calibration complete	This signal turns ON upon completion of load cell calibration. When the CLBR signal turns OFF, this signal also turns OFF.
	LOAD	Load output judgment signal	During push-motion operation, this signal is output when the current value set for the "threshold" is exceeded within the range of "Zone+" and "Zone-" set in the position data table. The signal is used to determine if press-fitting action has been performed correctly.
	TRQS	Torque level output	This signal is output when the motor current reaches the current value set for the "threshold" in the position data table after the slider (rod) has collided with an obstacle, etc., during movement in push-motion operation.
	LS0~LS2	Limit switch output	This signal turns ON when the current actuator position enters the in-position band set before and after the target position. If the home return has already completed, this signal is output even before a movement command is issued or while the servo is OFF.
ALM1~ALM8	Alarm code output signal	The alarm code is output together with the alarm sign output. Refer to Alarm List for details. (Dedicated pulse-train type)	
PWR	System ready	This signal turns ON if SCON is controllable after main power ON. (Dedicated pulse-train type)	
TLR	Torque limiting signal	This signal turns ON once the motor torque has reached the specified value in a condition where torque is being limited by the TL signal. (Dedicated pulse-train type)	

* In the above table, signals preceded by * are normally ON and turn OFF while the actuator is operating.

I/O Wiring Diagram

Positioning mode/Teaching mode/Solenoid valve mode
PIO connector (NPN specification)

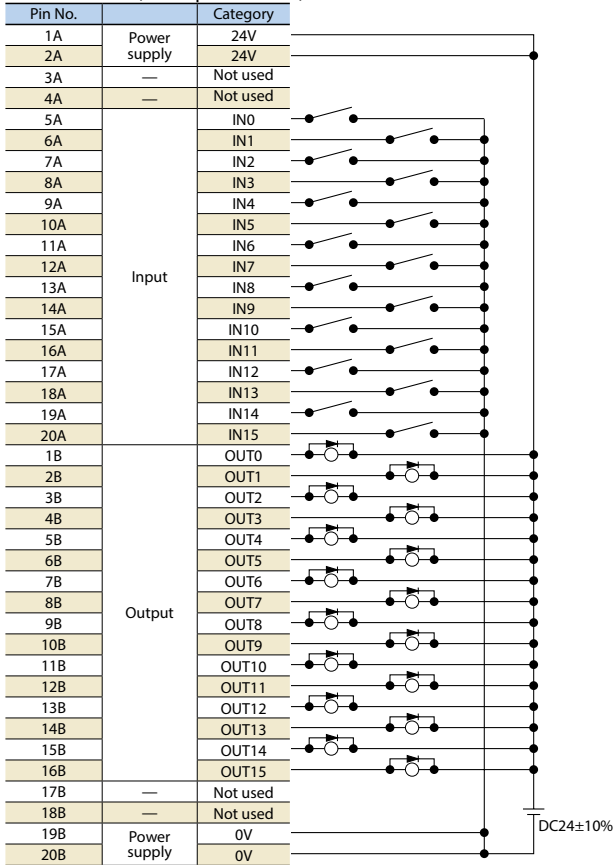

*Connect Pins 1A and 2A to 24V, and Pins 19B and 20B to 0V.

Pulse Train Mode (Differential Output)

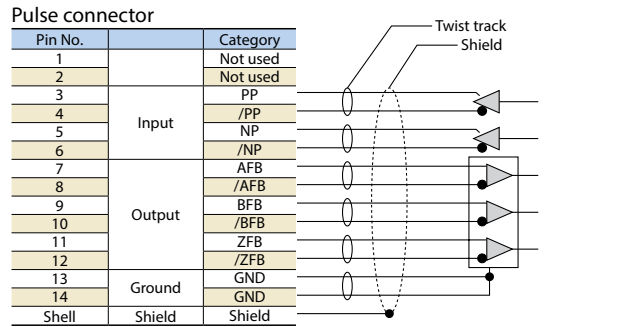

PIO connector (NPN specification)

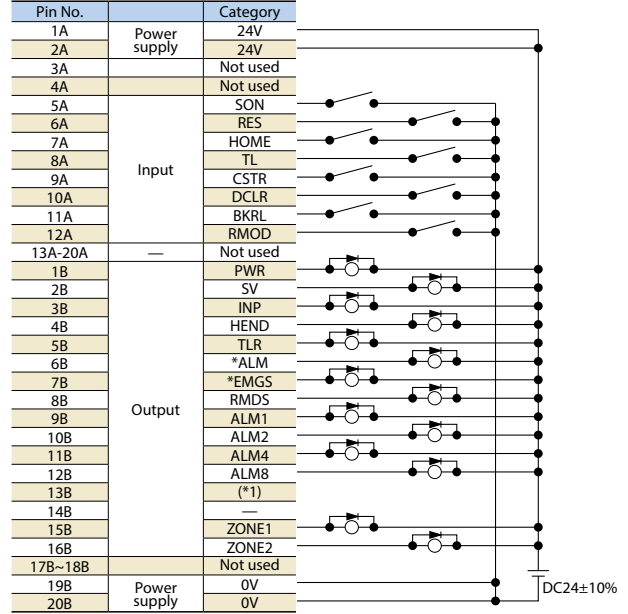

* Be sure to connect to the shell the shield of the twist track cable connected to the PULSE connector. Also keep the cable length to 10m or less.

* Connect Pins 1A and 2A to 24V, and Pins 19B and 20B to 0V

(*1)-/*ALM/*OVWL/*BALM (switchable with parameters)

I/O Specification

Input Part External Input Specification

Item	Specification
Input voltage	24VDC±10%
Input current	4mA/1 circuit
ON/OFF voltage	ON voltage: 18VDC min. OFF voltage: 6VDC max.
Isolation method	Photocoupler

NPN specification

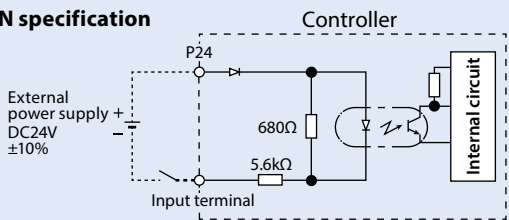

PNP specification

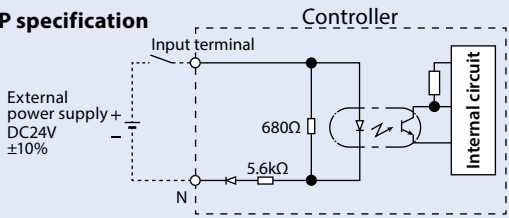

Output Part External Output Specifications

Item	Specification
Load voltage	24VDC
Maximum load current	100mA/1 point, 400mA/8 points
Leak current	0.1mA max./1 point
Isolation method	Photocoupler

NPN specification

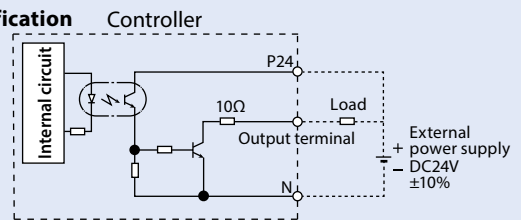

PNP specification

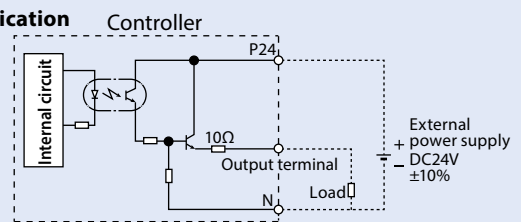

PMEC
AMEC

PSEP
ASEP
DSEP

MSEP

ERC3

ERC2

PCON
-CA

PCON

ACON

SCON
-CA

MSCON

PSEL

ASEL

SSEL

XSEL

PS-24

Pulse
Motor

Servo
Motor
(24V)

Servo
Motor
(200V)

Linear
Servo
Motor

Pulse-Train Type I/O Specification (Differential Line Driver Specification)

Input Part

Maximum number of input pulses: Line driver interface 2.5Mpps
Isolation method : Photocoupler isolation

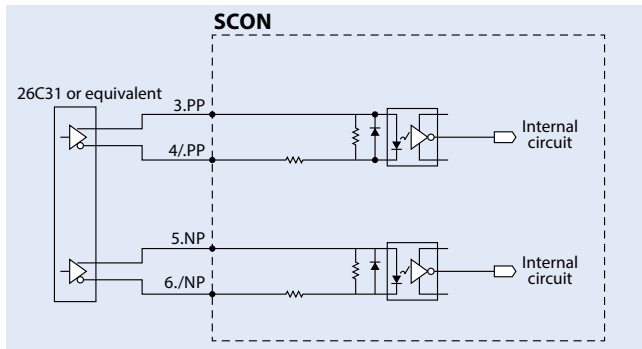

Output Part

Maximum number of output pulses: Line driver interface 2.5Mpps
Isolation/non-isolation : Non-isolation

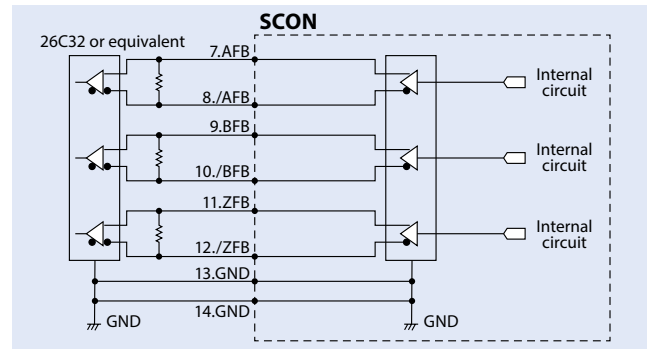

Pulse-Train Type I/O Specification (Open-collector Specification)

The AK-04 (Option) is needed to input pulses. The JM-08 (Option) is needed to output pulses.

Maximum number of input pulses:
200kpps (The AK-04 is needed.)
Maximum number of output pulses:
200kpps (The JM-08 is needed.)

- * The 24-VDC power supply connected to the AK-4 must be shared with the PIO interface.
- * Keep the length of the cable connecting the pulse output unit (PLC) and AK-04/JM-08 as short as possible. Also keep the cable between the AK-04/JM-08 and PULSE connector to 2m or less.

Note

Use the same power supply for open collector input/output to/from the host and for the AK-04, JM-08.

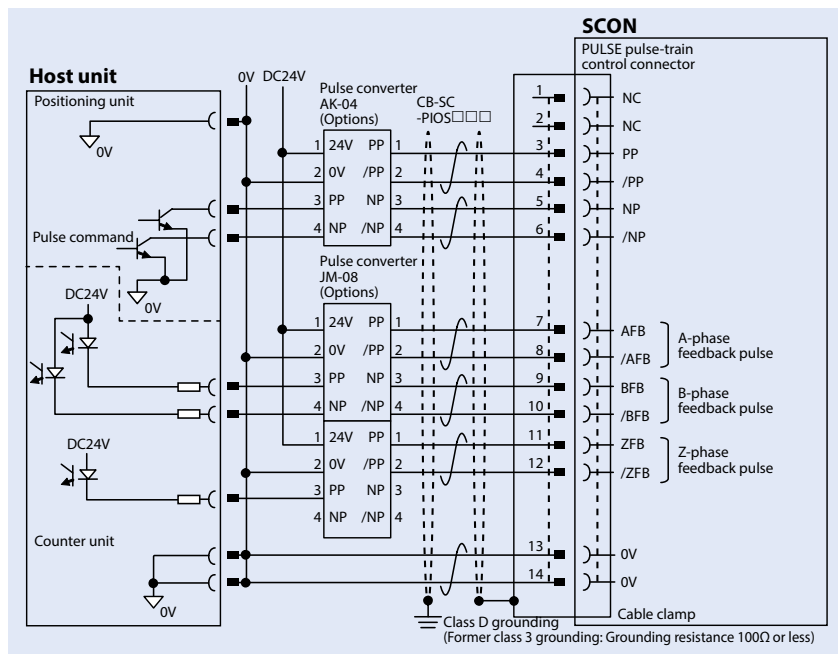

Command Pulse Input Patterns

Command pulse train pattern		Input terminal	Forward	Reverse	
Negative logic	Forward pulse-train	PP-/PP	[Pulse train diagram]	[Pulse train diagram]	
	Reverse pulse-train	NP-/NP	[Pulse train diagram]	[Pulse train diagram]	
	A forward pulse-train indicates the amount of motor rotation in the forward direction, while a reverse pulse-train indicates the amount of motor rotation in the reverse direction.				
	Pulse-train	PP-/PP	[Pulse train diagram]	[Pulse train diagram]	
	Sign	NP-/NP	Low	High	
The command pulse is used for the amount of motor rotation, while the sign indicates the rotating direction.					
Positive logic	Phase A/B pulse-train	PP-/PP	[Pulse train diagram]	[Pulse train diagram]	
		NP-/NP	[Pulse train diagram]	[Pulse train diagram]	
	Command phases A and B having a 90° phase difference (multiplier is 4) indicate the amount of rotation and the rotating direction.				
	Forward pulse train	PP-/PP	[Pulse train diagram]	[Pulse train diagram]	
	Reverse pulse-train	NP-/NP	[Pulse train diagram]	[Pulse train diagram]	
Linear Servo Motor	Pulse-train	PP-/PP	[Pulse train diagram]	[Pulse train diagram]	
	Sign	NP-/NP	High	Low	
	Phase A/B pulse-train	PP-/PP	[Pulse train diagram]	[Pulse train diagram]	
	NP-/NP	[Pulse train diagram]	[Pulse train diagram]		

Specification Table

Item	Specification	
Applicable motor capacity	Less than 400W	400W or more
Connected actuator	RCS2/RCS3 series actuator/single-axis robot/linear servo actuator	
Number of controlled axes	1 axis	
Operation method	Positioner type/pulse-train type	
Number of positioning points	512 points (PIO specification), 768 points (fieldbus specification)	
Backup memory	Nonvolatile memory (FRAM)	
I/O connector	40-pin connector	
Number of I/O points	16 input points/16 output points	
I/O power supply	Externally supplied 24VDC±10%	
Serial communication	RS485 1ch	
Peripherals communication cable	CB-PAC-PIO□□□	
Command pulse-train input method (Note 1)	Differential line driver output supported	
Maximum input pulse frequency	Differential line driver method: 2.5Mpps max./Open-collector method (pulse converter used): 200kpps max.	
Position detection method	Incremental encoder/absolute encoder	
Emergency stop function	Available (built-in relay)	
Forced electromagnetic brake release	Brake release switch ON/OFF	
Input power supply	Single-phase AC90V to AC126.5V Single-phase AC180V to AC253V	Single-phase AC180V to AC253V
Power-supply capacity (Note 2)	20W/74VA 30W (other than RS)/94VA 30W (RS)/186VA 60W/186VA 100W/282VA 150W/376VA 200W/469VA	100W (LSA-N10)(*)/331VA 200W (LSA-S10H, N15S)(*)/534VA 200W (LSA-N15H)(*)/821VA 300W (LSA-N19)(*)/710VA 400W/968VA 600W/1212VA 750W/1569VA
Vibration resistance	XYZ directions – 10 to 57Hz: Single amplitude 0.035mm (continuous), 0.075mm (intermittent) 58 to 150Hz: 4.9 m/s ² (continuous), 9.8 m/s ² (intermittent)	
Ambient operating temperature	0 ~ 40°C	
Ambient operating humidity	85%RH or less (non-condensing)	
Operating ambience	Not exposed to corrosive gases	
Protection degree	IP20	
Mass	Approx. 900g (+ 25g for the absolute specification)	Approx. 1.2kg (+ 25g for the absolute specification)
External dimensions	58mm (W) x 194mm (H) x 121mm (D)	72mm (W) x 194mm (H) x 121mm (D)

(Note 1) For the command pulse input method, use the differential line driver method resistant to noise. If the open-collector method must be used, use the optional pulse converter (AK-04/JM-08) to convert open-collector pulses to differential pulses.

(Note 2) Controllers operating any of the actuator models denoted by (*) shall conform to the external dimensions of controllers for 400 W or more, even when the output is less than 400W.

* The number of encoder pulses for the ROBO Cylinders operable with SCON-CA are:
 RCS2-SRA7BD/SRGS7BD/SRGD7BD — 3072 pulses
 RCS2-□□5N — 1600 pulses
 other models — 16384 pulses.

- PMEC
- AMEC
- PSEP
- ASEP
- DSEP
- MSEP
- ERC3
- ERC2
- PCON-CA
- PCON
- ACON
- SCON-CA
- MSCON
- PSEL
- ASEL
- SSEL
- XSEL
- PS-24

- Pulse Motor
- Servo Motor (24V)
- Servo Motor (200V)
- Linear Servo Motor

- Controller
- PMEC
AMEC
- PSEP
ASEP
DSEP
- MSEP
- ERC3
- ERC2
- PCON
-CA
- PCON
- ACON
- SCON
-CA
- MCON
- PSEL
- ASEL
- SSEL
- XSEL
- PS-24
- Pulse Motor
- Servo Motor (24V)
- Servo Motor (200V)
- Linear Servo Motor

External dimensions

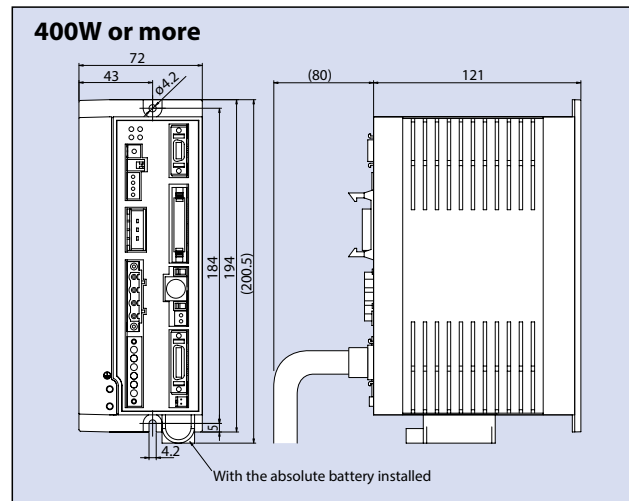
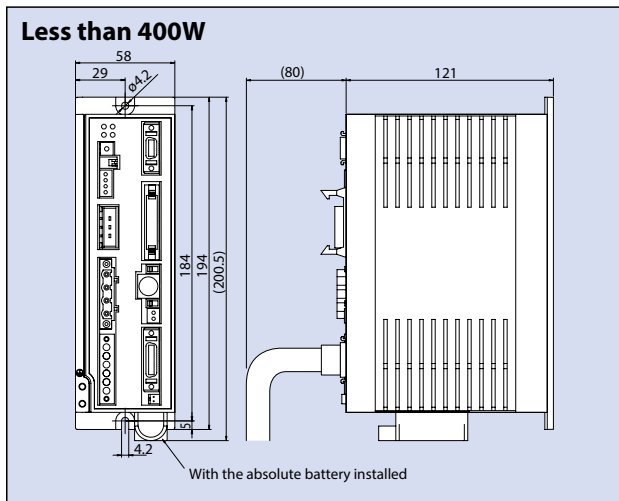

Name of Each Part

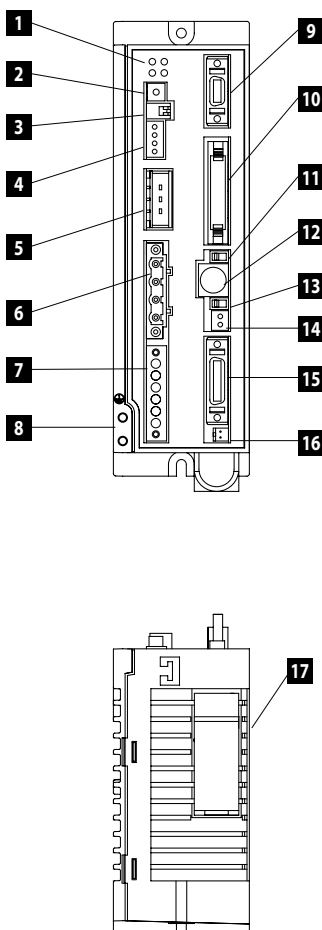

1 LED display

These LED colors indicate the condition of the controller.

Name	Color	Explanation
PWR	Green	Lit when the system is ready (after power is ON CPU normal functions)
SV	Green	Lit when servo is ON
ALM	Orange	Lit during an alarm
EMG	Red	Lit during an emergency stop

2 Rotary switch

This is the address setting switch for identifying each controller when they are linked.

3 Piano switch

Controller system switch.

Name	Explanation
1	Operating mode switch OFF: positioner mode ON: pulse train control mode *Enabled at power ON.
2	Remote update switch (normally set to OFF) OFF: normal operating mode ON: update mode *Enabled when power is ON or during soft reset.

4 System I/O connector

Connector for the emergency stop switch etc.

5 Regeneration unit connector

Connector for resistance unit that absorbs regeneration current produced when the actuator decelerates to a stop.

6 Motor connector (X-SEL, ECON, RCS compatible)

Actuator motor cable connector.

7 Power supply connector

AC power connector. Divided into the control power input and motor power input.

8 Grounding screw

Protective grounding screw. Always ground this screw.

9 Pulse train control connector

This connector is used during pulse train control mode operations. It is disconnected during operations in positioner mode.

10 PIO connector

Connector for the cable for parallel communications with the PLC and other peripheral devices.

11 Operating mode switch

Name	Explanation
MANU	Do not receive PIO commands
AUTO	Accept PIO commands

*The emergency stop switch on the teaching pendant becomes effective when the line is connected, regardless of whether this switch is set to AUTO or MANU. Take note that an emergency stop will be actuated momentarily when the teaching-pendant or SIO communication cable is disconnected. This is a normal phenomenon and does not indicate an error.

12 SIO connector

Connector for the teaching pendant or PC communications cable.

13 Brake release switch

This is the electromagnetic brake forced release switch, integrated with the actuator.

*It is necessary to connect the DC 24V power for the brake drive.

14 Brake power connector

Brake power DC 24V supply connector (only required when the brake equipped actuator is connected)

15 Encoder sensor connector (X-SEL-P/Q compatible)

Encoder sensor cable connector

16 Absolute battery connector

Connector for the absolute data backup battery. (Required only for absolute encoder specifications)

17 Absolute battery holder

Battery holder for installing the absolute data backup battery

Options

Teaching Pendant

- Features This teaching device offers position input, test operation, monitoring and other functions.
- Model
 - CON-PTA-C** (Standard type)
 - CON-PDA-C** (Deadman switch type)
 - CON-PGAS-C-S** (Safety-category compliant type)
 - CON-T** (Standard type)
 - CON-TGS** (Safety-category compliant type)
- Configuration

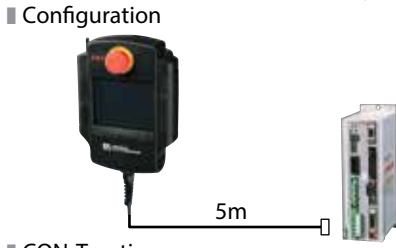
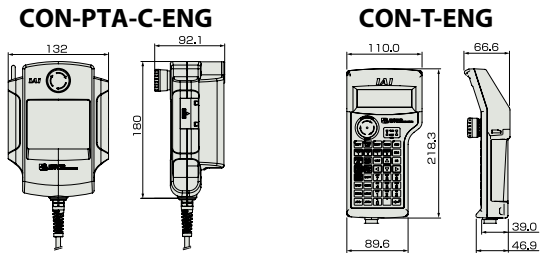

- CON-T options
 - Wall-mounting hook
Model: **HK-1**
 - Strap
Model: **STR-1**

Specification

Item	Touch panel teaching			Teaching pendant
	CON-PTA-C-ENG	CON-PDA-C-ENG	CON-PGAS-C-S-ENG	
Model	CON-PTA-C-ENG	CON-PDA-C-ENG	CON-PGAS-C-S-ENG	CON-T-ENG
Type	Standard	Deadman switch	Safety-category compliant	Standard
Display	65,536 colors (16 bit color) White LED backlight			20 characters x 4 lines LCD display
Ambient operating temperature/humidity	Temperature 0 to 40°C, humidity 85%RH or less (Non-condensing)			
Protection degree	IP40			IP54
Mass	Approx. 570g	Approx. 600g		Approx. 400g
Cable length	5m			
Accessories	Touch pen	Touch pen	Touch pen TP adapter (model: RCB-LB-TG) dummy plug (model: DP-4) controller connector cable (model: CB-CON-LB005)	—

PC Software (Windows Only)

- Features This startup support software provides functions to input positions, perform test operations and monitor data, among others. Incorporating all functions needed to make adjustments, this software helps shorten the initial startup time.
- Model number **RCM-101-MW** (With external device communication cable + RS232 conversion unit)
- Configuration

Supported Windows OS:
2000 SP4 or later / XP SP2 or later / Vista / 7

- Model number **RCM-101-USB** (With external device communication cable + USB adapter + USB cable)
- Configuration

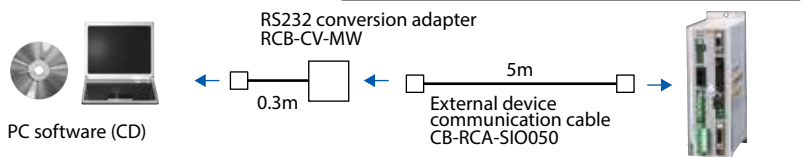

- Model number **RCM-101-USB** (With external device communication cable + USB adapter + USB cable)
- Configuration

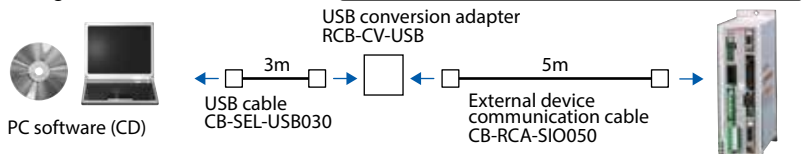

Regenerative Resistor Unit

- Features This unit converts regenerative current that generates when the motor decelerates, to heat. Check the total wattage of the actuators to be operated and provide a regenerative resistance unit or units if required.
- Model
 - RESU-2** (Standard specification)
 - RESUD-2** (DIN rail mount specification)
 - RESU-1** (Standard specification, second or subsequent unit)
 - RESUD-1** (DIN rail mount specification, second or subsequent unit)

* If two regenerative units are required, arrange one RESU-2/RESUD-2 (1st) and one RESU-1/RESUD-1 (2nd or after).

Guide for Required Quantity

	Horizontal	Vertical
0 unit	~ 100W	~ 100W
1 unit	~ 400W	~ 400W
2 units	~ 750W	~ 750W

Guide for Required Quantity (RCS2-RA13R only)

	Lead 2.5	Lead 1.25
Horizontal	1 unit	0 unit
Vertical	1 unit	1 unit

* The required regenerative resistance may be more than as specified above depending on the operating conditions.

* The required regenerative resistance may be more than as specified above depending on the operating conditions.

To operate the linear servo actuator LSA/LSAS-N10S□ with SCON controller, one regenerative resistance is required.

Absolute Data Backup Battery

- Features Absolute data backup battery used when an actuator of absolute specification is operated.
- Model number **AB-5**



Pulse Motor

Servo Motor (24V)

Servo Motor (200V)

Linear Servo Motor

SCON-CA Controller

Controller

Spare Parts

When you need spare parts after purchasing the product, such as when replacing a cable, refer to the list of models below.

Motor Cable/Motor Robot Cable

Model **CB-RCC-MA** □□□/ **CB-RCC-MA** □□□-**RB**

* Enter the cable length (L) into □□□. Compatible to a maximum of 30 meters.
Ex: 080 = 8 m

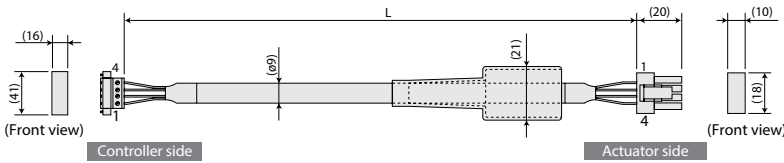

Min. bend radius $r = 50$ mm or larger
(when movable type is used)
* Only the robot cable is to be used in a cable track.

Wire	Color	Signal	Pin No.	Pin No.	Signal	Color	Wire
0.75sq	Green	PE	1	1	U	Red	0.75sq (crimped)
	Red	U	2	2	V	White	
	White	V	3	3	W	Black	
	Black	W	4	4	PE	Green	

Encoder Cable/Encoder Robot Cable

Model **CB-RCS2-PA** □□□/ **CB-X3-PA** □□□

* Enter the cable length (L) into □□□. Compatible to a maximum of 30 meters.
Ex: 080 = 8 m

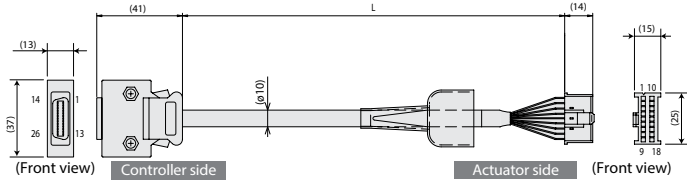

Min. bend radius $r = 50$ mm or larger
(when movable type is used)
* Only robot cable is to be used in a cable track.

Wire	Color	Signal	Pin No.	Pin No.	Signal	Color	Wire
-	-	-	10	1	A	Pink	
-	-	-	11	2	B	White	
-	-	-	12	3	A	Purple	
Gray/White	E24V	12	4	4	B	Blue/red	
Brown/White	OV	13	5	5	Z	Orange/White	
-	LS	26	6	6	Z	Green/White	
-	CREEP	25	7	7	L5+	Brown/White	
-	OV	24	8	8	-	-	
-	RSV	23	9	9	FG	Ground	
-	-	9	10	10	SD	Blue	
-	-	18	11	11	OV	Orange	
-	-	19/7	12	12	BAT+	Black	
Pink	A+	2	13	13	BAT	Yellow	
Purple	A-	2	14	14	VCC	Green	
White	B+	3	15	15	GND	Brown	
Blue/red	B-	4	16	16	VCC	Gray	
Orange/White	Z+	5	17	17	BK+	Red	
Green/White	Z-	6	18	18	BK-	Gray	
Blue	SBD+	7	19	19	BK-	Red	
Orange	SBD-	8	-	-	-	-	
Black	BAT+	14	-	-	-	-	
Yellow	BAT-	15	-	-	-	-	
Green	VCC	16	-	-	-	-	
Brown	GND	17	-	-	-	-	
Gray	BK+	20	-	-	-	-	
Red	BK-	21	-	-	-	-	
-	-	22	-	-	-	-	
-	-	-	-	-	-	-	

Encoder Cable/Encoder Robot Cable for RCS2-RT6/RT6R/RT7/RA13R

Model **CB-RCS2-PLA** □□□ / **CB-X2-PLA** □□□

* Enter the cable length (L) into □□□. Compatible to a maximum of 30 meters.
Ex: 080 = 8 m

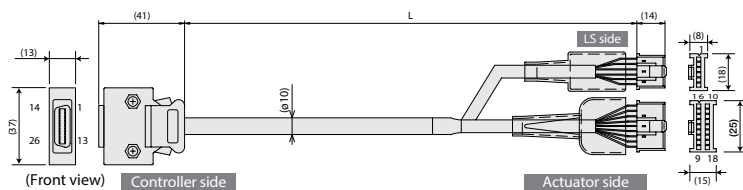

Min. bend radius $r = 50$ mm or larger
(when movable type is used)
* Only the robot cable is to be used in a cable track.

Wire	Color	Signal	Pin No.	Pin No.	Signal	Color	Wire
-	-	-	10	1	A	Pink	
-	-	-	11	2	B	White	
White/Orange	E24V	12	3	3	B	White/Blue	
White/Green	OV	13	4	4	OV	White/Orange	
Brown/Black	LS	26	5	5	LS	White/Green	
Brown/Yellow	CREEP	25	6	6	CREEP	Brown/Yellow	
Brown/Red	OV	24	7	7	OV	Brown/Red	
Brown/Black	RSV	23	8	8	RSV	Brown/Black	
-	-	9	9	9	-	-	
-	-	18	10	10	-	-	
-	-	19	11	11	-	-	
White/Blue	A+	1	12	12	A	White/Blue	
White/Red	A-	2	13	13	B	White/Red	
White/Black	B+	3	14	14	B	White/Black	
White/Purple	Z+	4	15	15	Z	White/Purple	
White/Gray	Z-	5	16	16	Z	White/Gray	
White/Gray	Z-	6	17	17	Z	White/Gray	
Orange	SBD+	7	18	18	-	-	
Green	SBD-	8	19	19	-	-	
Purple	BAT+	14	20	20	FG	Ground	
Gray	BAT-	15	21	21	SD	Orange	
Black	VCC	16	22	22	OV	Green	
Blue	GND	17	23	23	BAT+	Purple	
Blue	BK+	20	24	24	BAT-	Gray	
Yellow	BK-	21	25	25	VCC	Red	
-	-	22	26	26	GND	Black	
-	-	-	27	27	-	-	
-	-	-	28	28	BK-	Blue	
-	-	-	29	29	BK+	Yellow	

Encoder cable/ Encoder Robot Cable for RCS2-RA13R Load Cell Specification

Model **CB-RCS2-PLLA** □□□ / **CB-RCS2-PLLA** □□□-**RB** * Enter the cable length (L) into □□□. Compatible to a maximum of 30meters. Ex: 080 = 8m

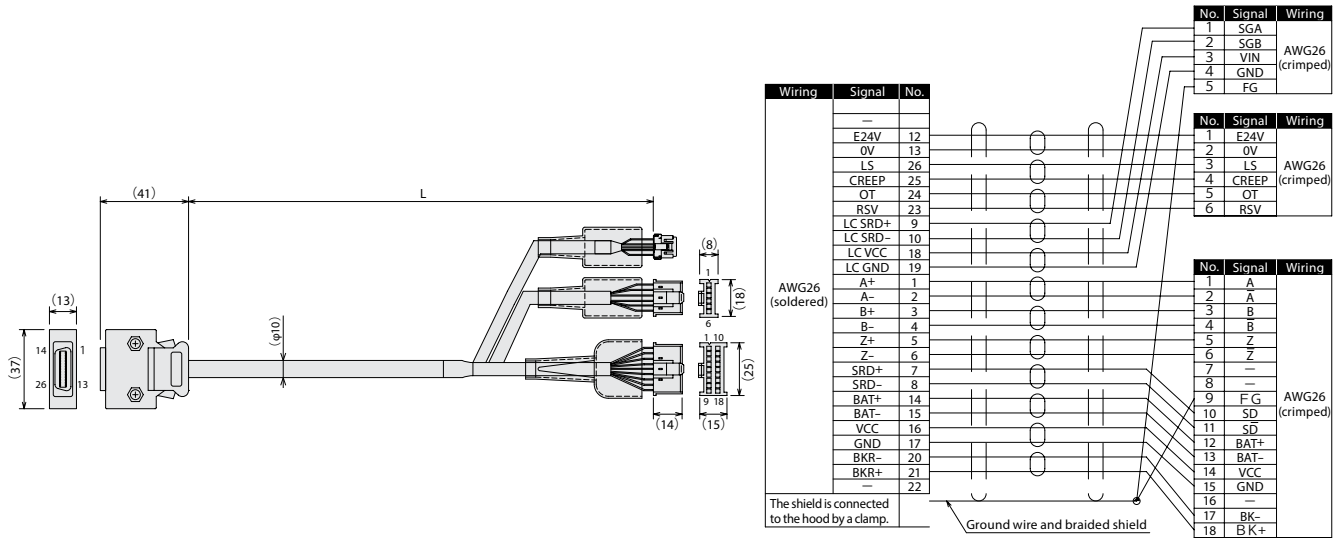

I/O Flat Cable

Model **CB-PAC-PIO** □□□ * Enter the cable length (L) into □□□. Compatible to a maximum of 10 meters. Ex: 080 = 8m

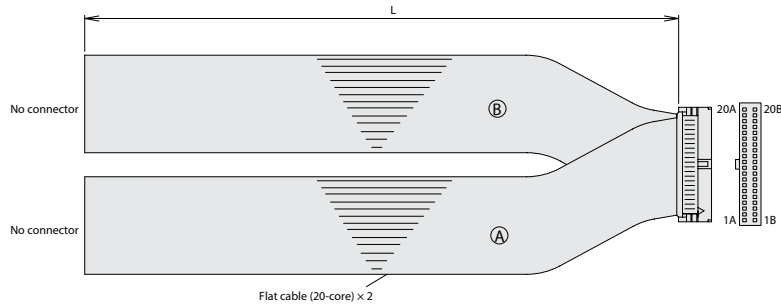

HIF6-40D-1, 27R

Pin No.	Signal	Color	Wire	Pin No.	Signal	Color	Wire
1A	24V	Brown-1	Flat cable (A) (crimped)	1B	OUT0	Brown-3	Flat cable (B) (crimped) AWG28
2A	24V	Red-1		2B	OUT1	Red-3	
3A	—	Orange-1		3B	OUT2	Orange-3	
4A	—	Yellow-1		4B	OUT3	Yellow-3	
5A	IN0	Green-1		5B	OUT4	Green-3	
6A	IN1	Blue-1		6B	OUT5	Blue-3	
7A	IN2	Purple-1		7B	OUT6	Purple-3	
8A	IN3	Gray-1		8B	OUT7	Gray-3	
9A	IN4	White-1		9B	OUT8	White-3	
10A	IN5	Black-1		10B	OUT9	Black-3	
11A	IN6	Brown-2		11B	OUT10	Brown-4	
12A	IN7	Red-2		12B	OUT11	Red-4	
13A	IN8	Orange-2		13B	OUT12	Orange-4	
14A	IN9	Yellow-2		14B	OUT13	Yellow-4	
15A	IN10	Green-2		15B	OUT14	Green-4	
16A	IN11	Blue-2		16B	OUT15	Blue-4	
17A	IN12	Purple-2		17B	—	Purple-4	
18A	IN13	Gray-2		18B	—	Gray-4	
19A	IN14	White-2		19B	0V	White-4	
20A	IN15	Black-2		20B	0V	Black-4	

SCON Pulse-Train Control Cable

Model **CB-SC-PIOS** □□□ * Enter the cable length (L) into □□□. Compatible to a maximum of 10 meters. Ex: 080 = 8m

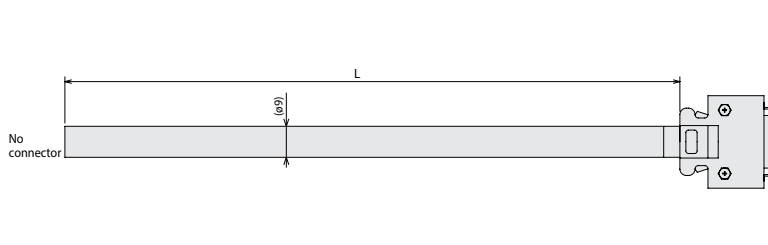

Wire	Color	Signal	Pin No.
Black	Black	Not used	1
White/Black	White/Black	Not used	2
Red	Red	PP	3
White/Red	White/Red	/PP	4
Green	Green	NP	5
White/Green	White/Green	/NP	6
Yellow	Yellow	AFB	7
White/Yellow	White/Yellow	/AFB	8
Brown	Brown	BFB	9
White/Brown	White/Brown	/BFB	10
Blue	Blue	ZFB	11
White/Blue	White/Blue	/ZFB	12
Gray	Gray	GND	13
White/Gray	White/Gray	GND	14

0.2sq soldered

- Controller
- PMEC
AMEC
- PSEP
ASEP
DSEP
- MSEP
- ERC3
- ERC2
- PCON
-CA
- PCON
- ACON
- SCON
-CA
- MSCON**
- PSEL
- ASEL
- SSEL
- XSEL
- PS-24
- Pulse Motor
- Servo Motor (24V)
- Servo Motor (200V)
- Linear Servo Motor



ROBO Cylinder Position Controller
SCON Series, 6-axis Type

Features

1 Space-saving, low-cost, and easy to use

Six RCS2/RCS3 (SCON-CA) controllers are combined into one unit to save the installation space and achieve significant reduction in total cost.



**2 Movement by numerical specification via Field network
Substantially shorter transmission time**

MSCON controllers can be connected directly to key field networks such as DeviceNet, CC-Link, PROFIBUS-DP, CompoNet, EtherCAT(*) and EtherNet/IP.

Features of Network Specification

- 256 positioning points per axis
- Moving the actuator after numerically specifying the position to move to, and the speed
- Checking the current position in real time
- Significantly shorter communication time within the controller (approx. one-sixth compared to conventional controllers)

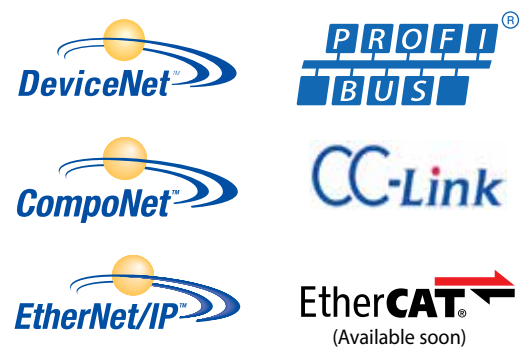

3 Offboard tuning function to enhance actuator payload capacity







The offboard tuning function increases the acceleration/deceleration speed when the load is small and decreases the acceleration/deceleration when the load is large, to ensure optimal operation settings according to the load. Also, servo tuning would be done at the same time. (See page A-98 for the details.)

4 Vibration control function for shorter cycle time

The vibration control function has been added to prevent the work part from shaking (vibrating) on the actuator slider as the slider moves. The wait time for vibration to stabilize is shorter and the cycle time can also be shortened.

655 MSCON

Model List/Standard Price

Model		MSCON-C						
External view								
I/O type		DeviceNet connection specification	CC-Link connection specification	PROFIBUS-DP connection specification	CompoNet connection specification	EtherCAT connection specification (Note)	EtherNet/IP connection specification	
								
I/O type model code		DV	CC	PR	CN	EC	EP	
Standard price	Number of axes	Encoder	Standard price					
	1 axis	Incremental	—	—	—	—	—	—
		Absolute	—	—	—	—	—	—
	2 axes	Incremental	—	—	—	—	—	—
		Absolute	—	—	—	—	—	—
	3 axes	Incremental	—	—	—	—	—	—
		Absolute	—	—	—	—	—	—
	4 axes	Incremental	—	—	—	—	—	—
		Absolute	—	—	—	—	—	—
	5 axes	Incremental	—	—	—	—	—	—
Absolute		—	—	—	—	—	—	
6 axes	Incremental	—	—	—	—	—	—	
	Absolute	—	—	—	—	—	—	

Available soon (Note)

Model Description

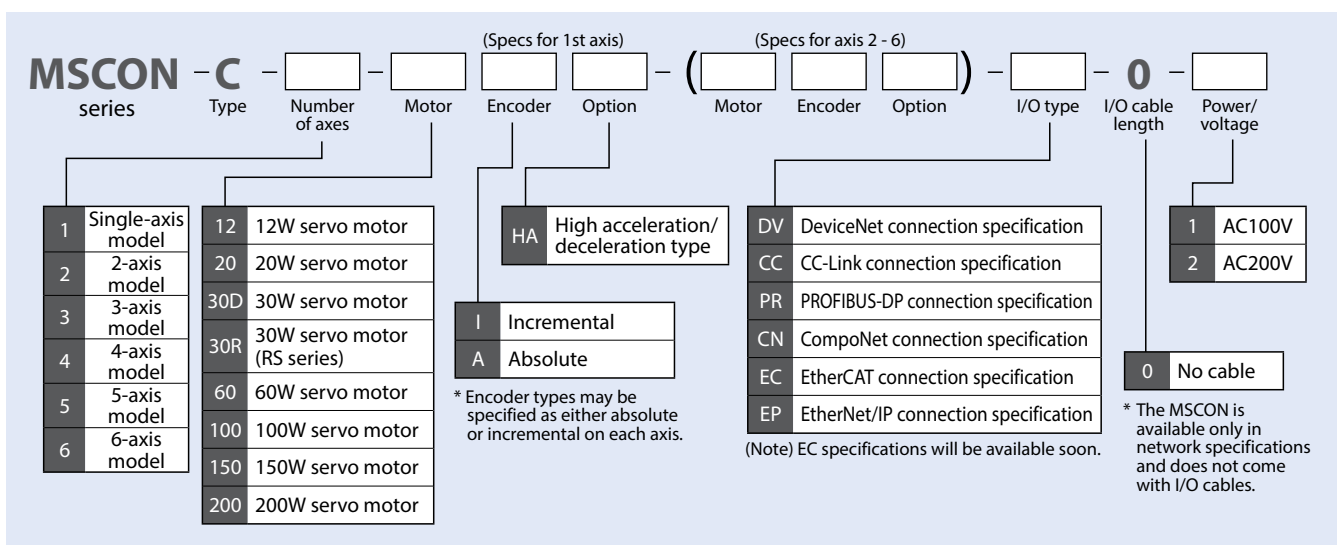

System Configuration

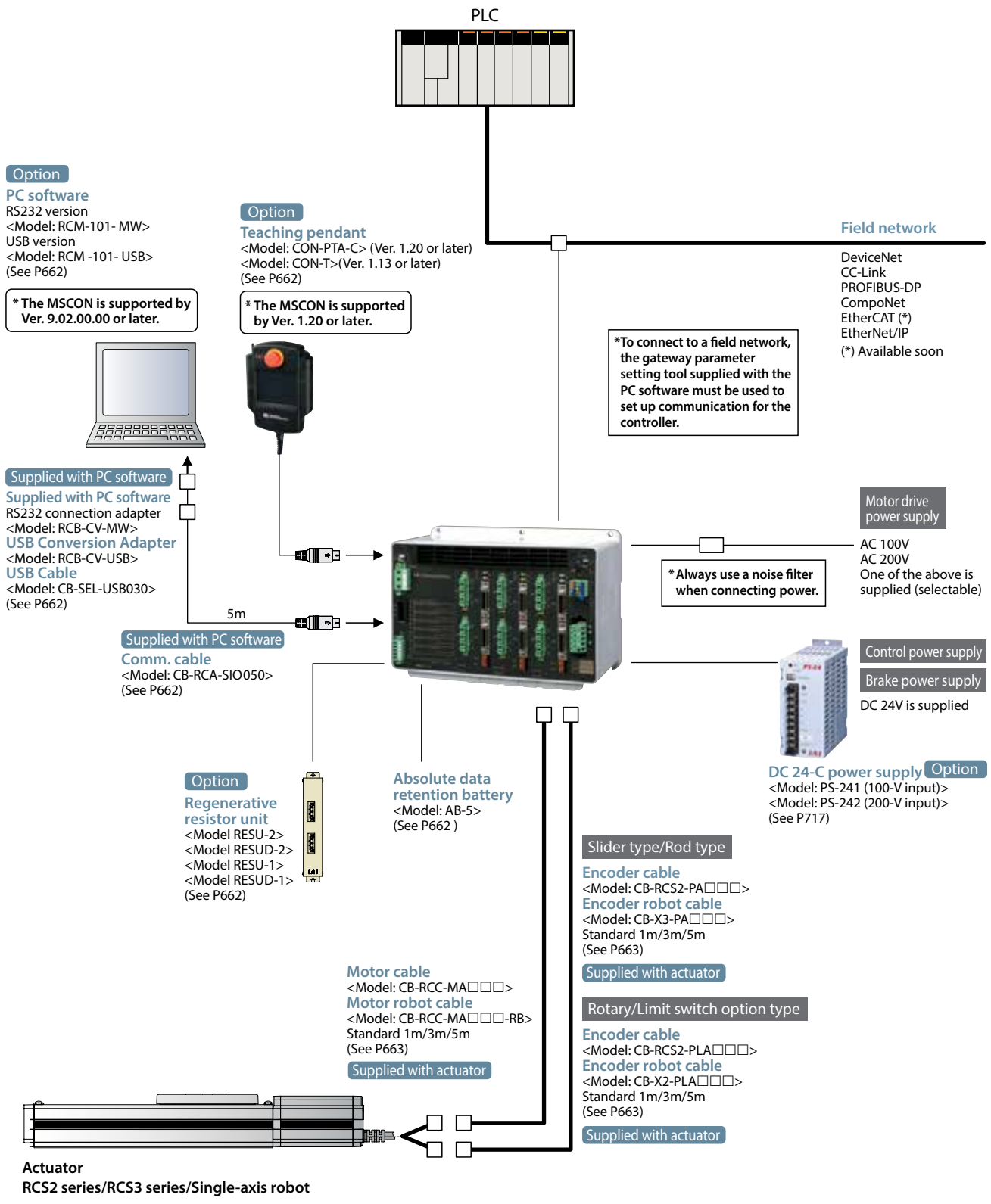

Note Take note that the following models are not supported by the MCON:
All linear servo actuator models, RCS2-RN5N/RP5N/GS5N/GD5N/SD5N/TCA5N/TWA5N/TFA5N/SRA7BD/SRGS7BD/SRGD7BD,
NS-SXM□/SZM□ (both incremental specifications only)

Operation Mode

When the MSCON is controlled via a field network, one of the following seven operation modes can be used. The necessary data areas on the PLC side vary depending on the mode, so please consult the MSCON controller manual or contact IAI before use.

Mode	Description
Simple direct input mode	The target position is specified by directly entering a value, while other operating conditions (speed, acceleration, etc.) are set by specifying the desired position number corresponding to the desired operating conditions already input to the position data table.
Positioner 1 mode	The target position, speed, acceleration/deceleration, etc., are input to the position data table of the controller and input position numbers are specified to operate the actuator (maximum 256 points). The current position can be read, as well.
Direct input mode	The actuator is operated by specifying the target position, speed, acceleration/deceleration, push current control value, etc., by directly entering values. The current position, current speed, command current, etc., can also be read.
Direct input mode 2	Same as the direct input mode, except that the jog operation is not supported and vibration control is added.
Positioner 2 mode	Same as the positioner 1 mode, except that the target position is not specified and reading of current position not supported, in order to reduce the amount of data to be transmitted/received.
Positioner 3 mode	Same as the positioner 2 mode, with the amount of data to be transmitted/received reduced further to allow for actuator operation with minimum input/output signals.
Remote I/O mode (*)	In this mode, the actuator is operated by controlling the ON/OFF of bits via the network, just like with the PIO specification. The number of positioning points and functions vary with each of the operation patterns (PIO patterns) that can be set by the controller's parameter.

(*) Take note that if the remote I/O mode is selected, all axes will operate in the remote I/O mode.

(*) With CompoNet, either positioner 3 mode or remote I/O mode can be selected.

List of Functions for Operation Mode

	Simple direct input mode	Positioner 1 mode	Direct input mode	Direct input mode 2	Positioner 2 mode	Positioner 3 mode
Number of positions	Unlimited	256 points	Unlimited	Unlimited	256 points	256 points
Home return operation	○	○	○	○	○	○
Positioning operation	○	△	○	○	△	△
Speed & acceleration/deceleration setting	△	△	○	○	△	△
Pitch feed (inching)	△	△	○	○	△	△
Push-motion operation	△	△	○	○	△	△
Speed change during movement	△	△	○	○	△	△
Pause	○	○	○	○	○	○
Zone signal output	△	△	△	△	△	△
Vibration control	△	△	X	○	△	△
Reading of current value	○	○	○	○	X	X
Selection of PIO pattern	X	X	X	X	X	X

*○Indicates that direct setting is possible; △ indicates that position data or parameter must be input; and X indicates that the function is not supported. (Note 1) PIO pattern is fixed to "8".

	Remote I/O mode				
	Positioning mode	Teaching mode	256-point mode	Solenoid valve mode 1	Solenoid valve mode 2
Number of positions	64 points	64 points	256 points	7 points	3 points
Home return operation	○	○	○	○	X
Positioning operation	△	△	△	△	△
Speed & acceleration/deceleration setting	△	△	△	△	△
Pitch feed (inching)	△	△	△	△	X
Push-motion operation	△	△	△	△	X
Speed change during movement	△	△	△	△	X
Pause	○	○	○	○	X
Zone signal output	△	△	△	△	△
Vibration control	△	△	△	△	△
Reading of current value	X	X	X	X	X
Selection of PIO pattern	○	○	○	○	○

*○ indicates that direct setting is possible; △ indicates that position data or parameter must be input; and X indicates that the function is not supported.

PMEC
AMEC

PSEP
ASEP
DSEP

MSEP

ERC3

ERC2

PCON
-CA

PCON

ACON

SCON
-CA

MSCON

PSEL

ASEL

SSEL

XSEL

PS-24

Pulse
Motor

Servo
Motor
(24V)

Servo
Motor
(200V)

Linear
Servo
Motor

Explanation of I/O Signal Functions

The table below explains the functions assigned to the controller's I/O signals.

The controller can be operated by setting the remote I/O mode, selecting one of modes 0 to 5, and then turning each port number ON/OFF via the network.

Classification		Setting of MSCON Parameter No. 25									
		Positioning mode		Teaching mode		256-point mode		Solenoid valve mode 1		Solenoid valve mode 2	
		0		1		2		4		5	
Port No.	Code	Signal name	Code	Signal name	Code	Signal name	Code	Signal name	Code	Signal name	
PLC output ↓ MSCON input	0	PC1	Command position number	PC1	Command position number	PC1	Command position number	ST0	Start position 0	ST0	Start position 0
	1	PC2		PC2		PC2		ST1	Start position 1	ST1	Start position 1
	2	PC4		PC4		PC4		ST2	Start position 2	ST2	Start position 2
	3	PC8		PC8		PC8		ST3	Start position 3	—	Cannot be used
	4	PC16		PC16		PC16		ST4	Start position 4	—	
	5	PC32		PC32		PC32		ST5	Start position 5	—	
	6	—	MODE	Teaching mode command	PC64	—	ST6	Start position 6	—		
	7	—	Cannot be used	JISL	Jog/inch switching	PC128	—	Cannot be used	—		
	8	—	Cannot be used	JOG+	Jogging in + direction	—	Cannot be used	—	Cannot be used	—	
	9	BKRL	Forced brake release	JOG-	Jogging in - direction	BKRL	Forced brake release	BKRL	Forced brake release	BKRL	Forced brake release
	10	—	Cannot be used	—	Cannot be used	—	Cannot be used	—	Cannot be used	—	Cannot be used
	11	HOME	Home return	HOME	Home return	HOME	Home return	HOME	Home return	—	
	12	*STP	Pause	*STP	Pause	*STP	Pause	*STP	Pause	—	
	13	CSTR	Positioning start	CSTR/PWRT	Positioning start/position data load command	CSTR	Positioning start	—	Cannot be used	—	
	14	RES	Reset	RES	Reset	RES	Reset	RES	Reset	RES	Reset
15	SON	Servo ON command	SON	Servo ON command	SON	Servo ON command	SON	Servo ON command	SON	Servo ON command	
MSCON output ↓ PLC input	0	PM1	Complete position number	PM1	Complete position number	PM1	Complete position number	PE0	Position complete 0	LS0	Rear end movement command 0
	1	PM2		PM2		PM2		PE1	Position complete 1	LS1	Rear end movement command 1
	2	PM4		PM4		PM4		PE2	Position complete 2	LS2	Rear end movement command 2
	3	PM8		PM8		PM8		PE3	Position complete 3	—	Cannot be used
	4	PM16		PM16		PM16		PE4	Position complete 4	—	
	5	PM32		PM32		PM32		PE5	Position complete 5	—	
	6	MOVE	Moving signal	MOVE	Moving signal	PM64	—	PE6	Position complete 6	—	
	7	ZONE1	Zone 1	MODES	Teaching mode signal	PM128	—	ZONE1	ZONE1	ZONE1	
	8	PZONE/ ZONE2	Position zone/ Zone 2	PZONE/ ZONE1	Position zone/ Zone 1	PZONE/ ZONE1	Position zone	PZONE/ ZONE2	Position zone/ Zone 2	PZONE/ ZONE2	Position zone/ Zone 2
	9	—	Cannot be used	—	Cannot be used	—	Cannot be used	—	Cannot be used	—	Cannot be used
	10	HEND	Home return complete	HEND	Home return complete	HEND	Home return complete	HEND	Home return complete	HEND	Home return complete
	11	PEND	Positioning complete signal	PEND/ WEND	Positioning complete signal/position data load complete	PEND	Positioning complete signal	PEND	Positioning complete signal	—	Cannot be used
	12	SV	Ready	SV	Ready	SV	Ready	SV	Ready	SV	Ready
	13	*EMGS	Emergency stop	*EMGS	Emergency stop	*EMGS	Emergency stop	*EMGS	Emergency stop	*EMGS	Emergency stop
	14	*ALM	Alarm	*ALM	Alarm	*ALM	Alarm	*ALM	Alarm	*ALM	Alarm
15	*BALM	Absolute battery voltage low warning	*BALM	Absolute battery voltage low warning	*BALM	Absolute battery voltage low warning	*BALM	Absolute battery voltage low warning	*BALM	Absolute battery voltage low warning	

In the table above, * accompanying each code indicates a negative logic signal.

List of Base Controller Specifications

Item	Specification
Number of controlled axes	1 to 6 axes
Control power-supply voltage	DC 24V ± 10%
Control power-supply current consumption	2.4A max.
Control power-supply rush current (Note 1)	7A max., 5msec or less
Drive (motor) power-supply voltage	Drive power-supply voltage AC 100 V specification
	Drive power-supply voltage AC 200 V specification
Drive (motor) power-supply rush current (Note 1)	Drive power-supply voltage AC 100 V specification
	Drive power-supply voltage AC 200 V specification
Connectable actuator motor capacity	Drive power-supply voltage AC 100 V specification
	Drive power-supply voltage AC 200 V specification
Electromagnetic brake power-supply voltage (when actuator with brake is connected)	DC 24 V ± 10%
Brake power-supply current	1A max. per axis (0.5A per axis in steady state)
Brake power-supply rush current (Note 1)	10A max., 10msec or less
Leak current (Note 2)	3.5 mA (motor power supply) ◎ No leak current from the control power supply or brake power supply
Motor control method	Sinusoidal PWM vector current control
Applicable encoder	Incremental serial encoder Absolute serial encoder
Serial communication (SIO port: Teaching only)	RS485: 1 channel (conforming to Modbus protocol) / Speed: 9.6 to 230.4 kbps
External interface	DeviceNet, CC-Link, PROFIBUS-DP, CompoNet, MECHATROLINKII (*), EtherNet/IP, EtherCAT (*) Specifications supporting the interfaces denoted by (*) will be available soon.
Data setting/input method	PC software, touch panel teaching, gateway parameter setting tool
Data retention memory	Saving of position data and parameters to nonvolatile memory (Memory can be rewritten an unlimited number of times)
Number of positioning points	Max. 256 points (Not limited in the simple direct input mode or direct input mode) Note: The number of positioning points varies depending on the operation mode selected by the parameter.
LED display (installed on the front panel)	Driver status LED x 2 Fieldbus status LED x 2 Gateway status LED x 5 Power-supply status LED x 2
Electromagnetic brake forced release switch (installed on the front panel)	Switched between NOM (standard) and RLS (forced releases)
Protective function	Overload, overcurrent, overvoltage, etc.
Electric shock protection mechanism	Class I
Isolation resistance	DC 500V, 10 MΩ or more
Withstand voltage	AC 1500V for 1 minute
External dimensions	225W×154H×115D
Weight	Incremental specification (When drivers for 6 axes are installed)
	Absolute specification (When drivers for 6 axes are installed)
Cooling method	Forced air cooling
Environment	Ambient operating temperature
	Ambient operating humidity
	Operating ambience
	Protection degree

Note 1: Take note that the rush current value varies depending on the impedance of the power supply line.

Note 2: Leak current varies depending on the motor capacity to be connected, cable length, and ambient environment. To protect against leak current, measure leak current at locations where the earth leakage breaker is set.

An earth leakage breaker must be selected that serves the specific purpose required, such as fire protection and injury protection.
Use an earth leakage breaker of harmonic wave type (inverter type).

Power Supply Selection

With the MSCON controller, motor driver power (AC 100V/AC 200V) and control power (DC 24V) must be supplied separately. Check the necessary power-supply capacity according to the table below.

■ Motor Drive Power-supply Capacity

Actuator motor W number	Motor power supply capacity [VA]	Momentary maximum motor power-supply capacity [VA]	Heat output [W]
12	41	123	1.7
20	50	150	2.0
30D (other than RS)	47	141	2.0
30R (RS)	138	414	4.0
60	146	438	4.8
100	238	714	7.0
150	328	984	8.3
200	421	1263	9.2

RS: Rotational shaft

■ Selecting the Circuit Breaker

Select the circuit breaker as follows:

- Three times the rated current will flow through the controller during acceleration/deceleration. (Refer to "Momentary maximum motor power-supply capacity" above). Select a circuit breaker that will not trip when this current flows. If the selected circuit breaker trips under this current, select another breaker of the next higher rated current. (Confirm on the operation characteristic curve in the manufacturer's catalog to confirm that the circuit breaker will not trip.)
- Select a circuit breaker that will not trip due to rush current. (Confirm on the operation characteristic curve in the manufacturer's catalog to confirm that the circuit breaker will not trip.)
- Select a rated break current that will break the circuit even when a short-circuit current flows.
Rated break current > Short-circuit current = Primary power-supply capacity of circuit breaker / Power-supply voltage

Consider allowance when selecting the rated current of circuit breaker.

<Rated current of circuit breaker>
Total sum of motor power-supply capacities of all actuators connected [VA] / AC input voltage x Safety factor (Rough guide: 1.2 to 1.3)

PMEC
AMEC

PSEP
ASEP
DSEP

MSEP

ERC3

ERC2

PCON
-CA

PCON

ACON

SCON
-CA

MSCON

PSEL

ASEL

SSEL

XSEL

PS-24

Pulse
Motor

Servo
Motor
(24V)

Servo
Motor
(200V)

Linear
Servo
Motor

- Controller
- PMEC
AMEC
- PSEP
ASEP
DSEP
- MSEP
- ERC3
- ERC2
- PCON
-CA
- PCON
- ACON
- SCON
-CA
- MSCON**
- PSEL
- ASEL
- SSEL
- XSEL
- PS-24
- Pulse Motor
- Servo Motor (24V)
- Servo Motor (200V)
- Linear Servo Motor

Control Power-supply (DC 24-V) Capacity

Calculate the DC 24-V power-supply capacity as follows:

(1) Current consumption of control power supply: Select the applicable control power-supply current shown in the table below --- ①

Number of controlled axes (Note 1)	1 axis	2 axes	3 axes	4 axes	5 axes	6 axes
Heat generation from control power supply [W]	25.5	31.5	38.2	44.2	50.9	56.9
Control power-supply current [A]	1.1	1.3	1.6	1.8	2.1	2.4

(Note 1): Check the maximum number of controlled axes that can be connected to the MSCON. This information is available on the manufacturer's nameplate. MSCON-C-*...: * represents the maximum number of axes that can be connected.

(2) Current consumption of brake power supply: 1 A or 0.5 A (Note 2) x Number of actuators with brakes --- ②

(Note 2): When the brake is released, up to 1 A of current will flow per actuator for a period of approx. 100 ms.

If this maximum current can be accommodated by the DC 24-V power supply used which is capable of handling momentary load fluctuation at the time of peak load, etc., calculate at 0.5 A/unit. If not, calculate at 1 A/unit.

(3) Rush current of control power supply: 7 A/ --- ③

[Selection of power supply]

Normally a power supply whose rated current is approx. 1.3 times is selected by considering approx. 30% of allowance on top of the load current of ① + ② above. Since the current of ③ will flow for a short period, select a power supply of the "peak load accommodation" specification or having enough allowance. If the selected power supply has no allowance, voltage may drop momentarily. In particular, pay attention to the power supply with remote sensing function.

External Dimensions

Incremental specification

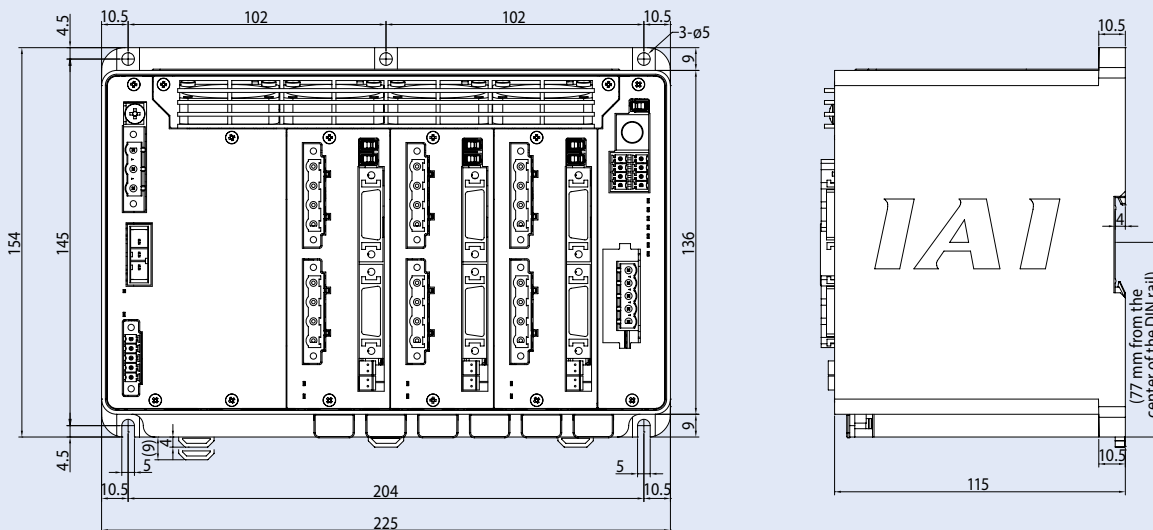

Absolute specification

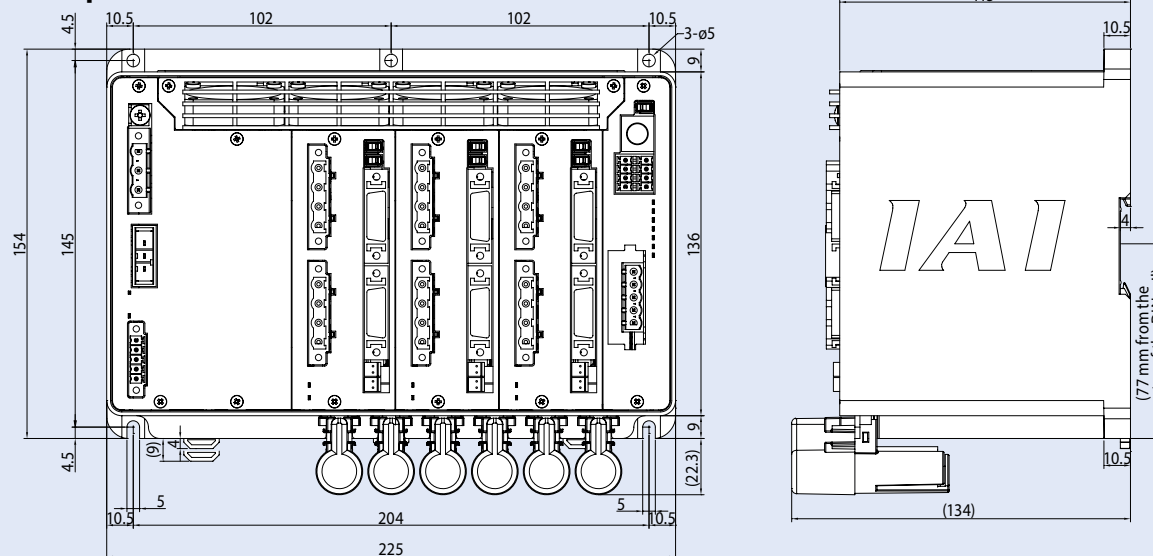

Options

Teaching Pendant

- Features Teaching device offering position input, test operation, monitoring and other functions.
- Model **CON-PTA-C** (Touch panel teaching)
CON-T (Standard type)

■ Configuration

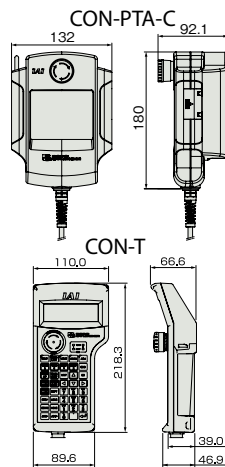
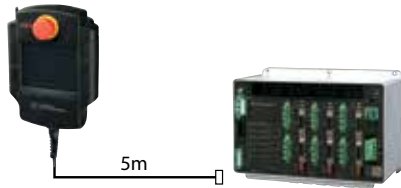

■ Specification

Item	Content	
	CON-PTA-C-ENG	CON-T-ENG
Data input	○	○
Actuator operation	○	○
Ambient operating temperature/humidity	Temperature 0 to 40°C, humidity 85%RH or less (Non-condensing)	
Operating ambience	Free from corrosive gases or significant powder dust.	
Protection degree	IP40	IP54
Weight	Approx. 570g	Approx. 400g
Cable length	5m	
Display	65,536 colors White LED backlight	20 characters x 4 lines LCD display
Standard price	—	—

PC Software (Windows dedicated)

- Features This startup support software provides functions to input positions, perform test operations and monitor data, among others. Incorporating all functions needed to make adjustments, this software helps shorten the initial startup time.

- Model **RCM-101-MW** (With external device communication cable + RS232 conversion unit)

■ Configuration

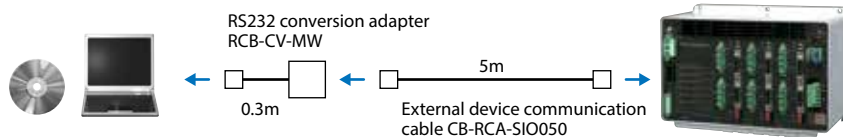

The MCON is supported by Ver. 9.02.00.00 or later.

Supported Windows OS:
2000 SP4 or later / XP SP2 or later / Vista / 7



- Model **RCM-101-USB** (With external device communication cable + USB conversion adapter + USB cable)

■ Configuration

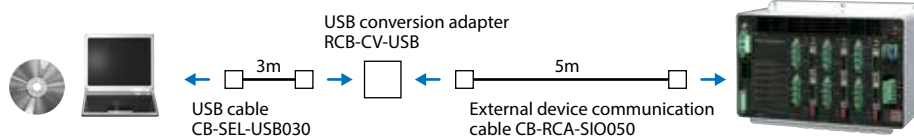

The MCON is supported by Ver. 9.02.00.00 or later.



Regenerative Resistor Unit

- Features This unit converts regenerative current that generates when the motor decelerates, to heat. Check the total wattage of the actuators to be operated and provide a regenerative resistance unit or units if required.

- Model **RESU-2** (Standard specification)
RESUD-2 (DIN rail mount specification)
RESU-1 (Standard specification, second or subsequent unit)
RESUD-1 (DIN rail mount specification, second or subsequent unit)

* If two regenerative units are required, arrange one RESU-2/RESUD-2 (1st) and one RESU-1/RESUD-1 (2nd or after).

■ Specification

Model	RESU-2	RESUD-2	RESU-1	RESUD-1
Connected to	MSCON controller		RESU-2/RESUD-2	
Supplied cable	CB-SC-REU010		CB-ST-REU010	
Unit installation method	Screw mount	DIN rail mount	Screw mount	DIN rail mount
Main unit weight	Approx. 0.4kg			
Built-in regenerative resistor	220 Ω, 80W			

* The first regenerative resistor unit connected to the MCON should be the RESU-2/RESUD-2. The regenerative resistor unit connected to this regenerative resistor unit should be the RESU-1/RESUD-1.

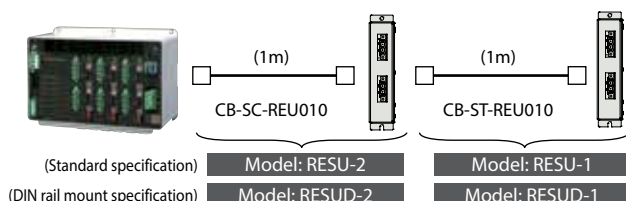

(Standard specification) Model: RESU-2
(DIN rail mount specification) Model: RESUD-2

Model: RESU-1
Model: RESUD-1

Absolute Data Backup Battery

- Features This is the battery to save the absolute data when the actuator with the absolute specification is operated.

- Model **AB-5** (battery only) / **AB-5-CS** (with case)



■ External dimensional drawing

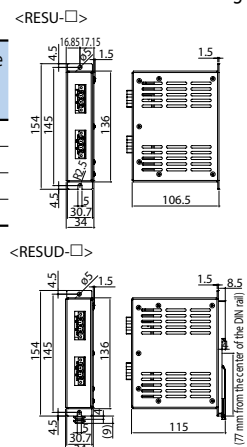

■ Reference Number of Units to Be Connected

Total wattage of 6 motor axes	Number of regenerative resistor units to be connected	
	Actuators installed horizontally	Actuators installed vertically
~450	~200	0
~900	~600	1
—	~800	2
—	~900	3

Note:
The numbers of units to be connected are reference values based on the following operating conditions:
(Conditions) Operate the actuator to travel back and forth over 1,000mm at the maximum speed, acceleration/deceleration of 0.3G, rated load, and operation duty of 50%.

Depending on the operating conditions, an error may generate and regenerative resistance greater than the applicable value shown in the table above may be required. In this case, add a regenerative resistor unit or units. Note that only up to four regenerative resistor units can be connected. If five or more units are connected, a failure may occur.

Maintenance Parts

Please refer to the models listed below if a cable needs to be exchanged, etc., after your purchase.

Motor cable/Motor robot cable

Model: **CB-RCC-MA** □□□ / **CB-RCC-MA** □□□ **-RB** * Enter the cable length (L) into □□□. Compatible to a Maximum of 30 meters. Ex.: 080 = 8m

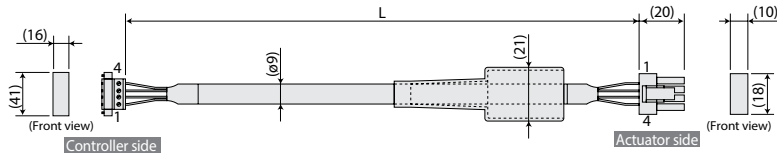

Wire	Color	Signal	No.	No.	Signal	Color	Wire
0.75sq	Green	PE	1	1	U	Red	0.75sq (crimped)
	Red	U	2	2	V	White	
	White	V	3	3	W	Black	
	Black	W	4	4	PE	Green	

Minimum bending R: r = 50 mm or more (when a robot cable is used)
* If the cable must be guided in a cable track, use a robot cable.

Encoder cable / Encoder robot cable

Model: **CB-RCS2-PA** □□□ / **CB-X3-PA** □□□

* Enter the cable length (L) into □□□. Compatible to a Maximum of 30 meters. Ex.: 080 = 8m

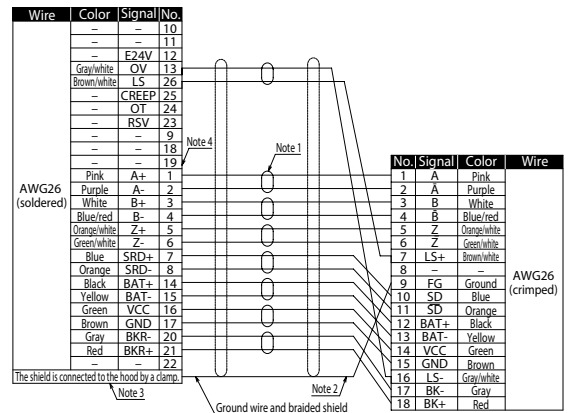
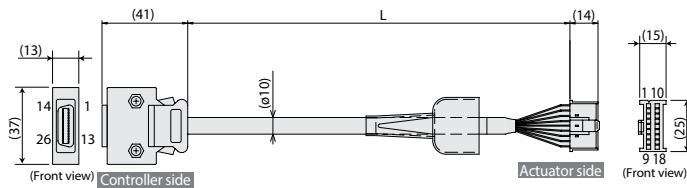

Minimum bending R: r = 50 mm or more (when a robot cable is used)
* If the cable must be guided in a cable track, use a robot cable.

Encoder cable / Encoder robot cable for RCS2-RT6/RT6R/RT7

Model: **CB-RCS2-PLA** □□□ / **CB-X2-PLA** □□□

* Enter the cable length (L) into □□□. Compatible to a Maximum of 30 meters. Ex.: 080 = 8m

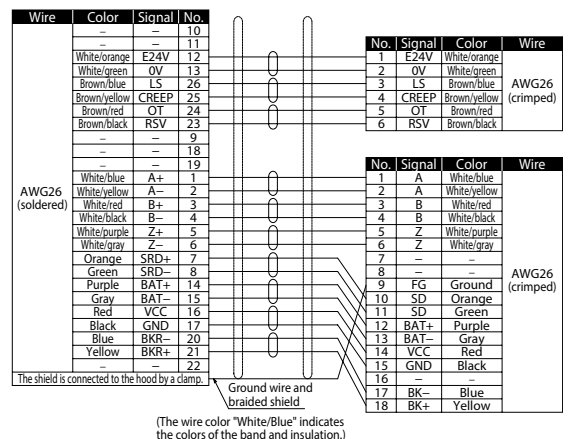
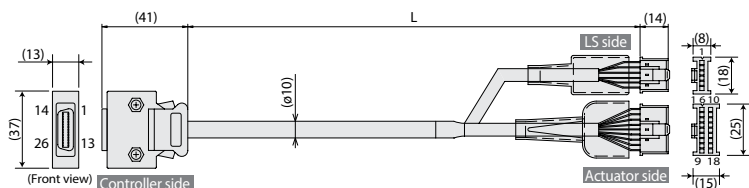

Minimum bending R: r = 50 mm or more (when a robot cable is used)
* If the cable must be guided in a cable track, use a robot cable.

MEMO

Controller

PMEC
AMEC

PSEP
ASEP
DSEP

MSEP

ERC3

ERC2

PCON
-CA

PCON

ACON

SCON
-CA

MSCON

PSEL

ASEL

SSEL

XSEL

PS-24

Pulse
Motor

Servo
Motor
(24V)

Servo
Motor
(200V)

Linear
Servo
Motor

IAI

MSCON

664
SOLD & SERVICED BY

ELECTROMATE

Toll Free Phone (877) SERV098
Toll Free Fax (877) SERV099
www.electromate.com
sales@electromate.com

- Controller
- PMEC
- AMEC
- PSEP
- ASEP
- DSEP
- MSEP
- ERC3
- ERC2
- PCON
- CA
- PCON
- ACON
- SCON
- CA
- MSCON
- PSEL**
- ASEL
- SSEL
- XSEL
- PS-24



Program controller
For RCP3/RCP2 Series

List of models

Program controller for operating RCP3/RCP2 Series actuators. Various control functions are combined into a single unit.

Type	CS	
Name	Program mode	Positioner mode
External view		
Description	Both the actuator operation and communication with external equipment can be handled by a single controller. When two axes are connected, arc interpolation, path operations, and synchronization can be performed.	Up to 1,500 positioning points are supported. Push-motion operation and teaching operation are also possible.
Position Points	1,500 points	
Standard Price	1 axis	—
	2 axes	—

Model

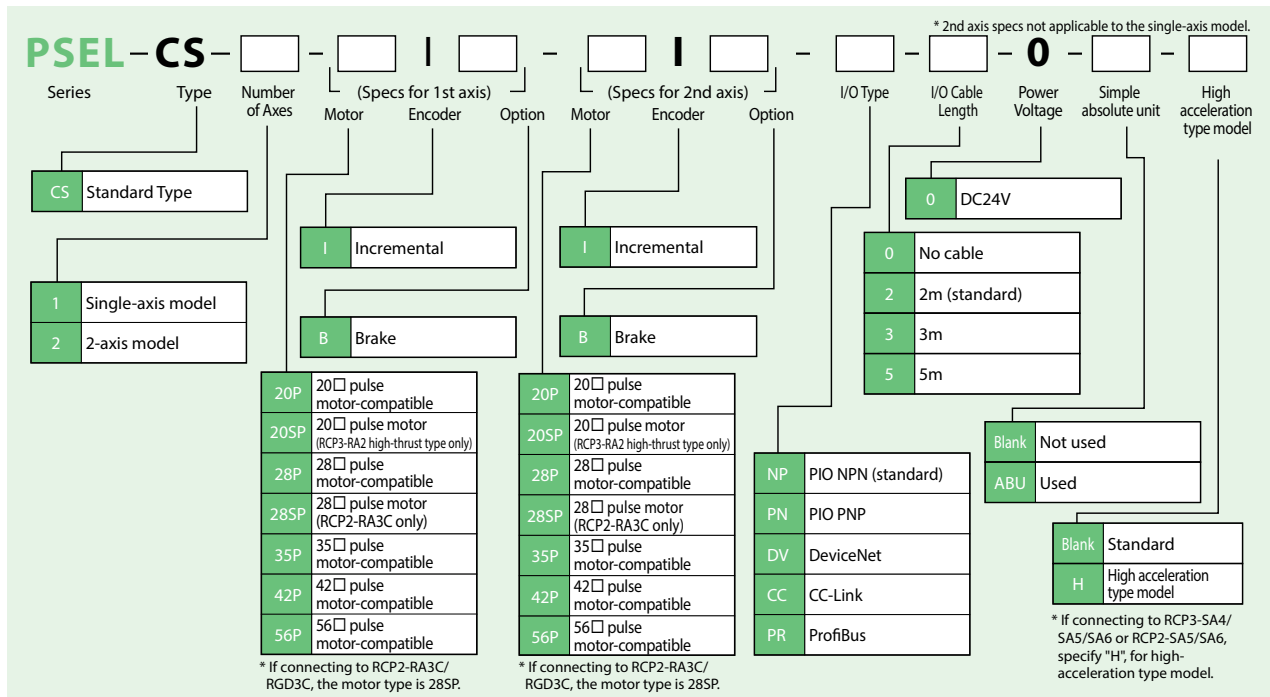

665 PSEL

System Configuration

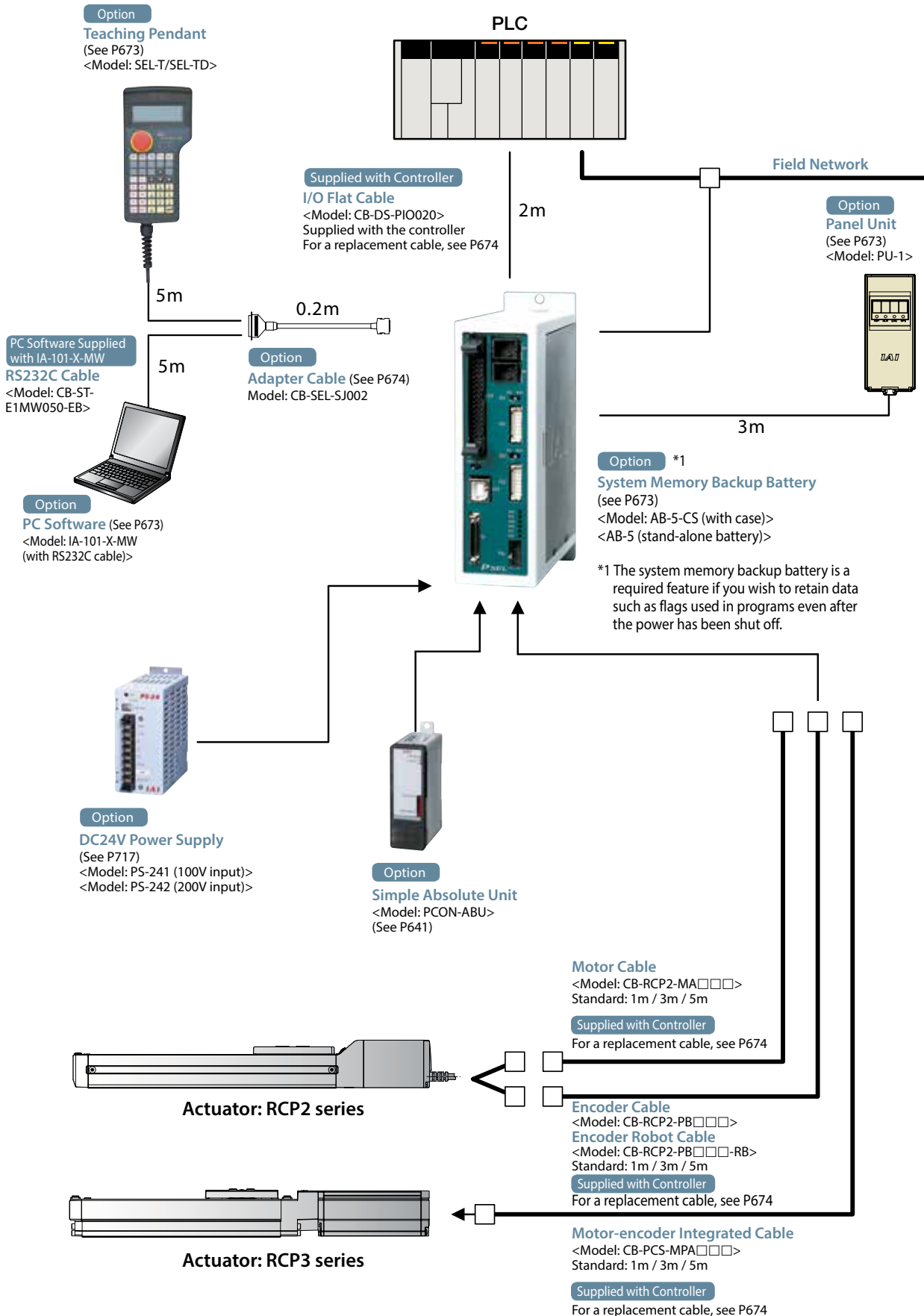

- Controller
- PMEC
AMEC
- PSEP
ASEP
DSEP
- MSEP
- ERC3
- ERC2
- PCON
-CA
- PCON
- ACON
- SCON
-CA
- MSCON
- PSEL**
- ASEL
- SSEL
- XSEL
- PS-24

I/O Specification

Input section External input specifications

Item	Specifications
Input voltage	DC24V ±10%
Input current	7mA/circuit
ON/OFF voltage	ON voltage (min.) NPN : DC16V / PNP : DC8V OFF voltage (max.) NPN : DC5V / PNP : DC19V
Isolation method	Photocoupler

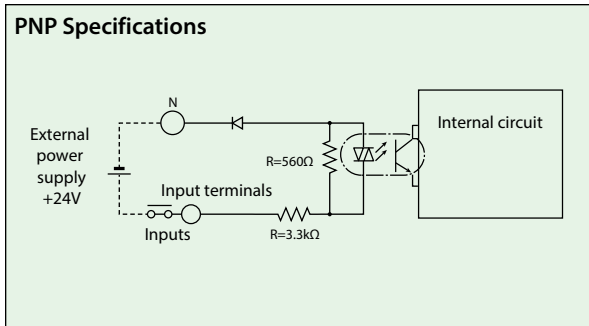
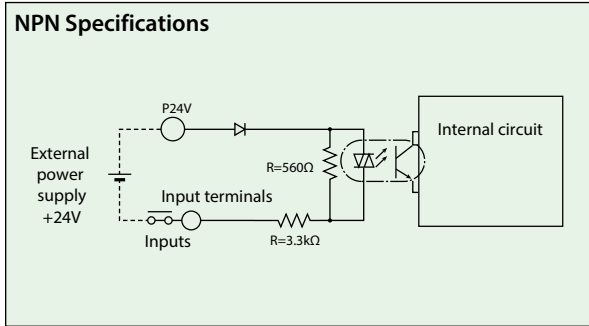

Output section External output specifications

Item	Specifications
Load Voltage	DC24V
Max. load current	100mA / 1 point 400mA / 8 points in total
Residual voltage (Max.)	Max 0.1mA / 1 point
Isolation method	Photocoupler

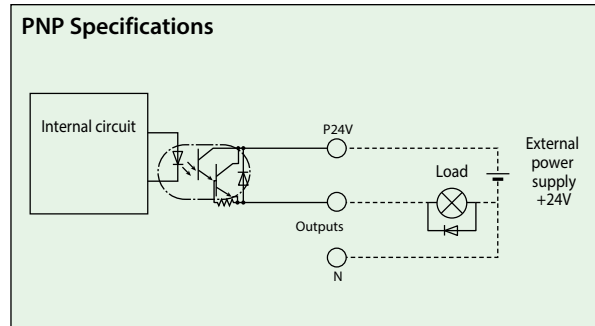
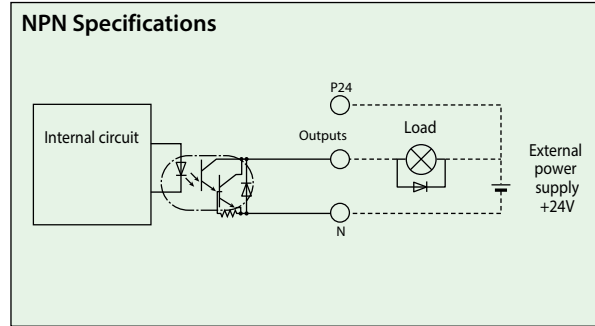

Explanation of I/O Signal Functions

Two modes can be selected for the SSEL controller: "Program Mode," in which the actuator is operated by entering a program, and "Positioner Mode," in which PLC signals are received and the actuator is moved to designated positions. The Positioner Mode has the five input patterns listed below to enable various applications.

Control Function by Type

Operation mode	Features
Program mode	Various operations including linear/arc interpolation operation, path operation ideal for coating processes, etc., arch-motion operation and palletizing operation can be performed using the Super SEL language that lets you program complex control actions using simple commands.
Positioner mode	Standard mode This is the basic mode from which operations can be conducted by designating position numbers and inputting the start signal. Push-motion operation and teaching operation are also possible.
	Product Change mode Multiple work parts of the same shape with slightly different hole positions can be handled using movement commands to the same position numbers by simply changing the product type number.
	2-axis independent mode With a 2-axis controller, each axis can be commanded and operated separately.
	Teaching mode In this mode, the slider (rod) moves based on an external signal, when the actuator is stopped, the current location can be registered as position data.
	DS-S-C1 Compatible mode If you were using a DS-S-C1 controller, you can replace it with a PSEL controller without having to change the host programs. *This mode does not ensure actuator compatibility.

- Pulse Motor
- Servo Motor (24V)
- Servo Motor (200V)
- Linear Servo Motor

Explanation of I/O Signal Functions

Program mode

Pin Number	Classification	Port No.	Program Mode	Functions	Wiring Diagram
1A	P24		24V input	Connect 24V.	
1B			016	Select Program No. 1	
2A			017	Select Program No. 2	
2B			018	Select Program No. 4	
3A			019	Select Program No. 8	
3B	020	Select Program No. 10			
4A	021	Select Program No. 20			
4B	022	Select Program No. 40			
5A	023	CPU reset	Resets the system to the same state as when the power is turned on.		
5B	000	Start	Starts the program selected by ports 016 to 022.		
6A	Input	001	General-purpose input	Waits for external input via program instructions.	
6B		002	General-purpose input		
7A		003	General-purpose input		
7B		004	General-purpose input		
8A		005	General-purpose input		
8B		006	General-purpose input		
9A		007	General-purpose input		
9B		008	General-purpose input		
10A		009	General-purpose input		
10B		010	General-purpose input		
11A		011	General-purpose input		
11B	012	General-purpose input			
12A	013	General-purpose input			
12B	014	General-purpose input			
13A	015	General-purpose input			
13B	Output	300	Alarm	Turns off when an alarm occurs. (Contact B)	
14A		301	Ready	Turns on when the controller starts up normally and is in an operable state.	
14B		302	General-purpose output	These outputs can be turned ON/OFF as desired via program instructions.	
15A		303	General-purpose output		
15B		304	General-purpose output		
16A		305	General-purpose output		
16B		306	General-purpose output		
17A	307	General-purpose output			
17B	N		0V input	Connect 0V.	

Note: This is for NPN. PNP will be different.

Positioner mode

Pin Number	Classification	Port No.	Positioner Standard Mode	Functions	Wiring Diagram
1A	P24		24V input	Connect 24V.	
1B			016	Position input 10	
2A			017	Position input 11	
2B			018	Position input 12	
3A			019	Position input 13	
3B	020	-	-		
4A	021	-	-		
4B	022	-	-		
5A	023	Error reset	Resets minor errors. (Severe errors require a restart.)		
5B	000	Start	Starts moving to selected position.		
6A	Input	001	Home return	Performs home return.	
6B		002	Servo ON	Switches between Servo ON and OFF.	
7A		003	Push	Performs a push motion.	
7B		004	Pause	Pauses the motion when turned OFF, and resumes when turned ON.	
8A		005	Cancel	Stops the motion when turned OFF. The remaining motion is canceled.	
8B		006	Interpolation settings	When this signal is turned ON for a 2-axis model, the actuator moves by linear interpolation.	
9A		007	Position input 1	Specifies the position numbers to move to, using ports 007 to 019. The number can be specified either as BCD or binary.	
9B		008	Position input 2		
10A		009	Position input 3		
10B		010	Position input 4		
11A		011	Position input 5		
11B	012	Position input 6			
12A	013	Position input 7			
12B	014	Position input 8			
13A	015	Position input 9			
13B	Output	300	Alarm	Turns off when an alarm occurs. (Contact B)	
14A		301	Ready	Turns on when the controller starts up normally and is in an operable state.	
14B		302	Positioning complete	Turns on when the movement to the destination is complete.	
15A		303	Home return complete	Turns on when the home return operation is complete.	
15B		304	Servo ON output	Turns on when servo is ON.	
16A		305	Pushing complete	Turns on when a push motion is complete.	
16B		306	System battery error	Turns on when the system battery runs low (warning level).	
17A	307	-	-		
17B	N		0V input	Connect 0V.	

Note: This is for NPN. PNP will be different.

Explanation of I/O Signal Functions

Positioner, Product-Type Change Mode

Pin Number	Classification	Port No.	Positioner Product Type Change Mode	Functions	Wiring Diagram		
1A	P24	016	24V input	Connect 24V.			
1B			Position/Product Type Input 10	Specifies the position numbers to move to, and the product type numbers, using ports 007 to 022. The position and product type numbers are assigned by parameter settings. The number can be specified either as BCD or binary.			
2A			Position/Product Type Input 11				
2B			Position/Product Type Input 12				
3A			Position/Product Type Input 13				
3B			Position/Product Type Input 14				
4A			Position/Product Type Input 15				
4B			Position/Product Type Input 16				
5A			023			Error reset	Resets minor errors. (Severe errors require a restart.)
5B			000			Start	Starts moving to selected position.
6A			001			Home return	Performs home return.
6B			002			Servo ON	Switches between Servo ON and OFF.
7A			003			Push	Performs a push motion.
7B			004			Pause	Pauses the motion when turned OFF, and resumes when turned ON.
8A			005			Cancel	Stops the motion when turned OFF. The remaining motion is canceled.
8B			006			Interpolation settings	When this signal is turned ON for a 2-axis model, the actuator moves by linear interpolation.
9A			007			Position/Product Type Input 1	Specifies the position numbers to move to, and the product type numbers, using ports 007 to 022. The position and product type numbers are assigned by parameter settings. The number can be specified either as BCD or binary.
9B	008	Position/Product Type Input 2					
10A	009	Position/Product Type Input 3					
10B	010	Position/Product Type Input 4					
11A	011	Position/Product Type Input 5					
11B	012	Position/Product Type Input 6					
12A	013	Position/Product Type Input 7					
12B	014	Position/Product Type Input 8					
13A	015	Position/Product Type Input 9					
13B	300	Alarm	Turns off when an alarm occurs. (Contact B)				
14A	301	Ready	Turns on when the controller starts up normally and is in an operable state.				
14B	302	Positioning complete	Turns on when the movement to the destination is complete.				
15A	303	Home return complete	Turns on when the home return operation is complete.				
15B	304	Servo ON output	Turns on when servo is ON.				
16A	305	Pushing complete	Turns on when a push motion is complete.				
16B	306	System battery error	Turns on when the system battery runs low (warning level).				
17A	307	—	—				
17B	N	0V input	Connect 0V.				

Note: This is for NPN. PNP will be different.

- PMEC
- AMEC
- PSEP
- ASEP
- DSEP
- MSEP
- ERC3
- ERC2
- PCON
- CA
- PCON
- ACON
- SCON
- CA
- MSCON
- PSEL**
- ASEL
- SSEL
- XSEL
- PS-24

Positioner, 2-axis Independent Mode

Pin Number	Classification	Port No.	Positioner 2-axis Independent Mode	Functions	Wiring Diagram		
1A	P24	016	24V input	Connect 24V.			
1B			Position input 7	Specifies the position numbers to move to, using ports 010 to 022. The position numbers on the 1st and 2nd axes are assigned by parameter settings. The number can be specified either as BCD or binary.			
2A			Position input 8				
2B			Position input 9				
3A			Position input 10				
3B			Position input 11				
4A			Position input 12				
4B			Position input 13				
5A			023			Error reset	Resets minor errors. (Severe errors require a restart.)
5B			000			Start 1	Starts the movement to the selected position number on the 1st axis.
6A			001			Home return 1	Performs home return on the 1st axis.
6B			002			Servo ON 1	Switches between servo ON and OFF for the 1st axis.
7A			003			Pause 1	Pauses the motion on 1st axis when turned OFF, and resumes when turned ON.
7B			004			Cancel 1	Cancels the movement on the 1st axis.
8A			005			Start 2	Starts the movement to the selected position number on the 2nd axis.
8B			006			Home return 2	Performs home return on the 2nd axis.
9A			007			Servo ON 2	Switches between servo ON and OFF for the 2nd axis.
9B	008	Pause 2	Pauses the motion on 2nd axis when turned OFF, and resumes when turned ON.				
10A	009	Cancel 2	Cancels the movement on the 2nd axis.				
10B	010	Position input 1	Specifies the position numbers to move to, using ports 010 to 022. The position numbers on the 1st and 2nd axes are assigned by parameter settings. The number can be specified either as BCD or binary.				
11A	011	Position input 2					
11B	012	Position input 3					
12A	013	Position input 4					
12B	014	Position input 5					
13A	015	Position input 6					
13B	300	Alarm	Turns off when an alarm occurs. (Contact B)				
14A	301	Ready	Turns on when the controller starts up normally and is in an operable state.				
14B	302	Positioning complete 1	Turns on when the movement to the specified position on the 1st axis is complete.				
15A	303	Home return complete 1	Turns on when home return on the 1st axis is complete.				
15B	304	Servo ON output 1	Turns on when the 1st axis is in a servo ON state.				
16A	305	Positioning complete 2	Turns on when the movement to the specified position on the 2nd axis is complete.				
16B	306	Home return complete 2	Turns on when home return on the 2nd axis is complete.				
17A	307	Servo ON output 2	Turns on when the 2nd axis is in a servo ON state.				
17B	N	0V input	Connect 0V.				

Note: This is for NPN. PNP will be different.

- Pulse Motor
- Servo Motor (24V)
- Servo Motor (200V)
- Linear Servo Motor

Explanation of I/O Signal Functions

Positioner, Teaching Mode

Pin Number	Classification	Port No.	Positioner Teaching Mode	Functions	Wiring Diagram	
1A	P24		24V input	Connect 24V.		
1B		016	JOG- on 1st axis	While the signal is on, the 1st axis is moved in the - (negative) direction.		
2A		017	JOG+ on 2nd axis	While the signal is on, the 2nd axis is moved in the + (positive) direction.		
2B		018	JOG- on 2nd axis	While the signal is on, the 2nd axis is moved in the - (negative) direction.		
3A		019	Specify inching (0.01mm)	Specifies how much to move during inching. (Total of the values specified for ports 019 to 022)		
3B		020	Specify inching (0.1mm)			
4A		021	Specify inching (0.5mm)			
4B		022	Specify inching (1mm)			
5A		023	Error reset	Resets minor errors. (Severe errors require a restart.)		
5B		000	Start	Starts moving to selected position.		
6A		001	Servo ON	Switches between Servo ON and OFF.		
6B		002	Pause	Pauses the motion when turned OFF, and resumes when turned ON.		
7A		Input	003	Position input 1		Ports 003 to 013 are used to specify the position number to move, and the position number for inputting the current position. - When the teaching mode setting on port 014 is in the ON state, the current value is written to the specified position number.
7B			004	Position input 2		
8A			005	Position input 3		
8B			006	Position input 4		
9A			007	Position input 5		
9B	008		Position input 6			
10A	009		Position input 7			
10B	010		Position input 8			
11A	011		Position input 9			
11B	012		Position input 10			
12A	013		Position input 11			
12B	014	Teaching mode setting				
13A	Output	015	JOG+ on 1st axis	While the signal is on, the 1st axis is moved in the + (positive) direction.		
13B		300	Alarm	Turns off when an alarm occurs. (Contact B)		
14A		301	Ready	Turns on when the controller starts up normally and is in an operable state.		
14B		302	Positioning complete	Turns on when the movement to the destination is complete.		
15A		303	Home return complete	Turns on when the home return operation is complete.		
15B		304	Servo ON output	Turns on when servo is ON.		
16A		305	—	—		
16B	306	System battery error	Turns on when the system battery runs low (warning level).			
17A	307	—	—			
17B	N		0V input	Connect 0V.		

Note: This is for NPN. PNP will be different.

Positioner, DS-S-C1 Compatible Mode

Pin Number	Classification	Port No.	Positioner DS-S-C1 Compatible Mode	Functions	Wiring Diagram	
1A	P24		24V input	Connect 24V.		
1B		016	Position No. 1000	(Same as ports 004 through 015)		
2A		017	—	—		
2B		018	—	—		
3A		019	—	—		
3B		020	—	—		
4A		021	—	—		
4B		022	—	—		
5A		023	CPU reset	Resets the system to the same state as when the power is turned on.		
5B		000	Start	Starts moving to selected position.		
6A		001	Hold (Pause)	Pauses the motion when turned ON, and resumes when turned OFF.		
6B		002	Cancel	Stops the motion when turned ON. The remaining motion is canceled.		
7A		Input	003	Interpolation settings		When this signal is turned ON for a 2-axis model, the actuator moves by linear interpolation.
7B			004	Position No. 1		Ports 004 through 016 are used to specify the position number to move. The numbers are specified as BCD.
8A			005	Position No. 2		
8B			006	Position No. 4		
9A			007	Position No. 8		
9B	008		Position No. 10			
10A	009		Position No. 20			
10B	010		Position No. 40			
11A	011		Position No. 80			
11B	012		Position No. 100			
12A	013		Position No. 200			
12B	014	Position No. 400				
13A	Output	015	Position No. 800			
13B		300	Alarm	Turns off when an alarm occurs. (Contact A)		
14A		301	Ready	Turns on when the controller starts up normally and is in an operable state.		
14B		302	Positioning complete	Turns on when the movement to the destination is complete.		
15A		303	—	—		
15B		304	—	—		
16A		305	—	—		
16B	306	System battery error	Turns on when the system battery runs low (warning level).			
17A	307	—	—			
17B	N		0V input	Connect 0V.		

Note: This is for NPN. PNP will be different.

- Controller
- PMEC
AMEC
- PSEP
ASEP
DSEP
- MSEP
- ERC3
- ERC2
- PCON
-CA
- PCON
- ACON
- SCON
-CA
- MSCON
- PSEL**
- ASEL
- SSEL
- XSEL
- PS-24

Table of Specifications

	Item	Specifications
Basic Specifications	Connected actuator	RCP2 series actuator (Note 1)
	Input voltage	DC24V ±10%
	Power Supply Capacity	Control power (Max. 1.2A) + Motor power (See the table below)
	Dielectric strength voltage	DC500V 10MΩ or higher
	Withstand voltage	AC500V 1 min.
	Rush current	Max. 30A
	Vibration resistance	XYZ directions 10 to 57Hz, One side amplitude: 0.035mm (continuous), 0.075mm (intermittent) 58 to 150 Hz 4.9 m/s ² (continuous), 9.8 m/s ² (intermittent)
Control specification	Maximum total output of connected axis	—
	Position detection method	Incremental encoder
	Speed setting	From 1mm/s. The maximum limit varies depending on the actuator.
	Acceleration setting	From 0.01G. The maximum limit varies depending on the actuator.
	Operating method	Program operation / Positioner operation (switchable)
Program	Programming language	Super SEL language
	Number of programs	64 programs
	Number of program steps	2,000 steps
	Number of multi-tasking programs	8 programs
	Positioning Points	1,500 points
	Data memory device	FLASHROM (A system-memory backup battery can be added as an option)
Communication	Data input method	Teaching pendant or PC software
	Number of I/O	24 input points / 8 output points (NPN or PNP selectable)
	I/O power	Externally supplied 24VDC ± 10%
	PIO cable	CB-DS-PIO□□□ (supplied with the controller)
	Serial communications function	RS232C (Half-pitch connector) / USB connector
	Field Network	DeviceNet, CC-Link, ProfiBus
	Motor Cable	CB-RCP2-MA□□□ (Max. 20m)
	Encoder cable	CB-RCP2-PA□□□ (Max. 20m)
General specifications	Protection function	Motor driver temperature check, Encoder open-circuit check Soft limit over, system error, battery error, etc.
	Ambient operating humidity and temperature	0 to 40°C 10 to 95% (non-condensing)
	Ambient atmosphere	Free from corrosive gases. In particular, there shall be no significant powder dust.
	Protection class	IP20
	Weight	Approx. 450g
	External dimension	43 mm (W) x 159 mm (H) x 110 mm (D)

(Note 1) Cannot operate High-Thrust type (RA10C), High-Speed type (HS8C/HS8R), or Waterproof type (RCP2W-SA16).

		1-Axis specifications		2-Axis specifications		
Motorpower supply Capacity (Note2)	Motor type	Rated	Max.(Note 3)	Rated	Max.(Note 3)	
		20P, 28P, 28SP motor	0.4A	2.0A	0.8A	4.0A
		35P, 42P, 56SP motor	1.2A		2.4A	

(Note 2) For both 1-axis and 2-axis specifications, approx. 30A inrush current flows for 5 ms when the control power supply is turned on.
 (Note 3) After Servo ON, excitation detection is performed. In that case, the current is maximized. (Approx. 100 msec)
 However, if motor drive power supply is turned on after a shut-down, approx. 6.0A and approx. 12.0A current flows to axis-1 and axis-2 respectively. (Approx. 1 to 2 msec)

Exterior Dimensions

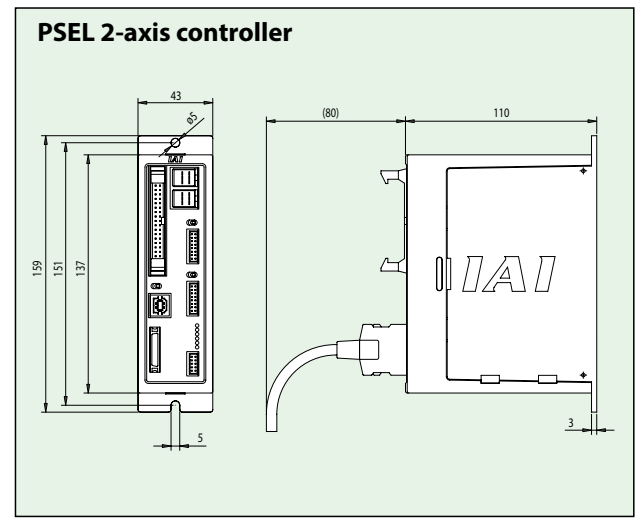
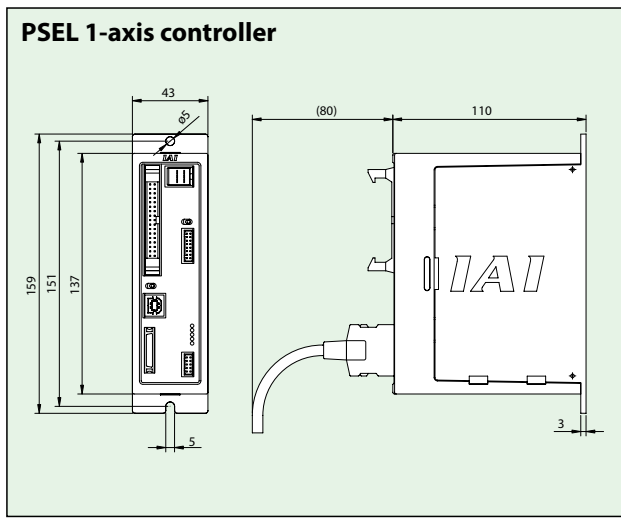

671

PSEL

Name of Each Part

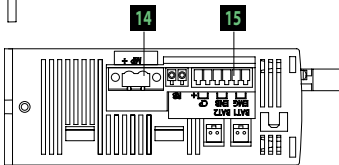
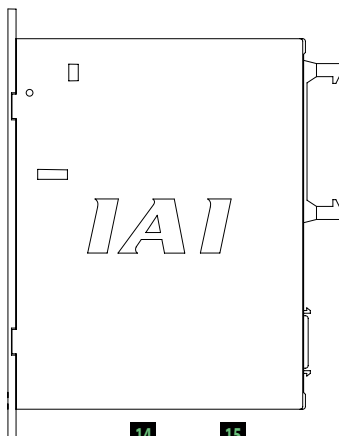
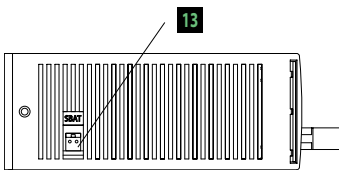
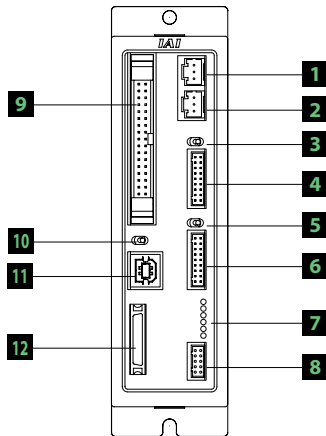

1 Motor connector for axis 1

Connects the motor cable of the axis 1 actuator.

2 Motor connector for axis 2

Connects the motor cable of the axis 2 actuator.

3 Brake switch for axis 1

This switch is used to release the axis brake. Setting it to the left position (RLS side) forcibly releases the brake, while setting it to the right position (NOM side) causes the controller to automatically control the brake.

4 Encoder connector for axis 1

Connect the encoder cable of the axis 1 actuator.

5 Brake switch for axis 2

This switch is used to release the axis brake. Setting it to the left position (RLS side) forcibly releases the brake, while setting it to the right position (NOM side) causes the controller to automatically control the brake.

Encoder connector for axis 2

Connect the encoder cable of the axis 2 actuator.

7 Status indicator LEDs

These LEDs are used to indicate the operating condition of the controller.

The LED status indicators are as follows:

- PWR : Power is input to controller.
- RDY : The controller is ready to perform program operation.
- ALM : The controller is abnormal.
- EMG : An emergency stop is actuated and the drive source is cut off.
- SV1 : The axis 1 actuator servo is on.
- SV2 : The axis 2 actuator servo is on.

8 Panel unit connector

A connector for the panel unit (optional) that displays the controller status and error codes.

9 I/O Connector

A connector for interface I/Os.

34-pin flat cable connector for DIO (24IN/8OUT) interface.

I/O power is also supplied to the controller via this connector (Pin No. 1 and No. 34).

10 Mode switch

This switch is used to specify the running mode of the controller. The left position indicates the MANU (manual operation) mode, while the right position indicates the AUTO (automatic operation) mode. Teaching can only be performed in manual operation, and automatic operation using external I/Os is not possible in the MANU mode.

11 USB connector

A connector for PC connection via USB. If the USB connector is connected, the TP connector is disabled and all communication inputs to the TP connector are cut off.

12 Teaching pendant connector

A half-pitch I/O 26-pin connector that connects a teaching pendant when the running mode is MANU. A special conversion cable is needed to connect a conventional D-sub, 25-pin connector.

13 System-memory backup battery connector

If you wish to retain the various data recorded in the SRAM of the controller even after the power is cut off, connect the necessary battery to this connector. This battery is installed externally to the unit. The controller does not come standard with the battery (Option).

14 Motor power input connector

This connector is used to input the motor power. It consists of a 2-pin, 2-piece connector by Phoenix Contact.

15 Control power/System input connector

This connector is used to connect the control power input, emergency stop switch, and enable switch. It consists of a Phoenix Contact 6-pin 2-piece connector.

Options

Teaching Pendant

Features This is a teaching device that provides information on functions such as position input, test runs, and monitoring.

Model

Model	Description
SEL-T-JS	Standard type with adapter cable
SEL-TD-JS	Equipped with a deadman switch and adapter cable

Configuration

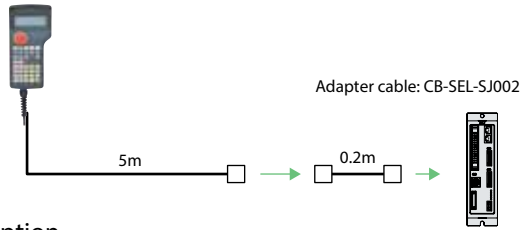

SEL-T option

- Wall-mounting hook Model **HK-1**
- Strap Model **STR-1**

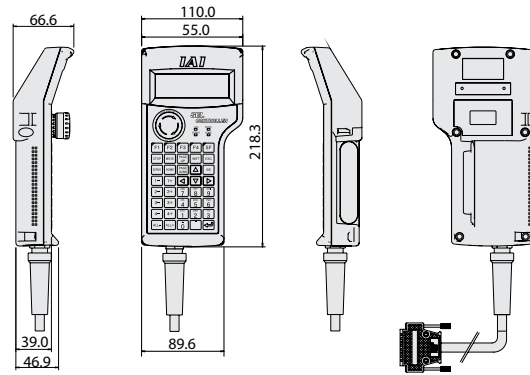

Specifications

Item	SEL-T-JS	SEL-TD-JS
3-position Enable Switch	No	Yes
ANSI/UL standards	Non-compliant	Compliant
CE mark	Compliant	
Display	20 char. x 4 lines	
Ambient Operating Temp./Humidity	0~40°C 10~90% RH (non-condensing)	
Protective structure	IP54	
Weight	Approx. 0.4kg (not incl. cable)	

PC Software (Windows Only)

Features A startup support software for inputting programs/positions, performing test runs, and monitoring. More functions have been added for debugging, and improvements have been made to shorten the start-up time.

Model **IA-101-X-MW-JS** (with RS232C cable + adapter cable)

Configuration

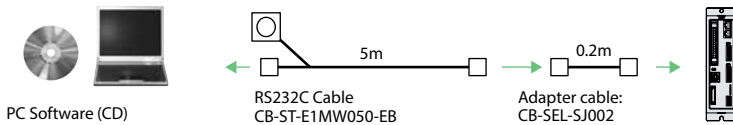

Supported Windows OS:
2000 SP4 or later / XP SP2 or later / Vista / 7

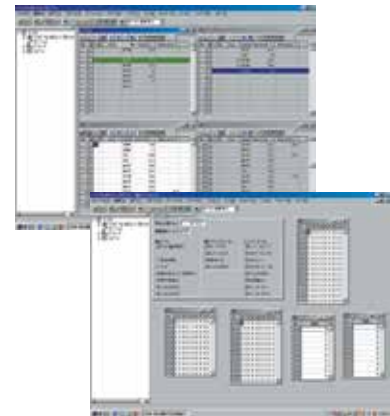

Model **IA-101-X-USBS** (with USB cable)

Configuration

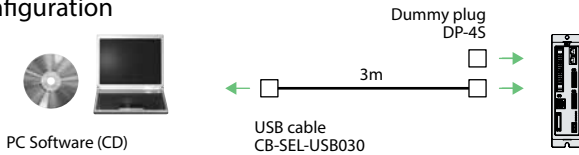

Note:
Only versions 7.0.0.0 and later can be used with the PSEL controller.

Panel Unit

Features Display device that shows the error code from the controller or the currently running program number.

Model **PU-1** (Cable length: 3m)

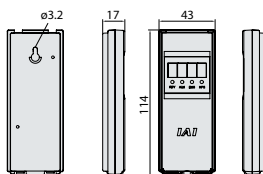

System Memory Backup Battery

Features This battery is required when you are using global flags in the program and you want to retain your data even after the power has been turned OFF.

Model **AB-5-CS (with case)**
AB-5 (stand-alone battery)



Dummy Plug

Features When connecting the PSEL controller to a computer with a USB cable, this plug is inserted in the teaching port to shut off the enable circuit. (Supplied with the PC software IA-101-X-USB)

Model **DP-4S**



Options

USB Cable

Features A cable for connecting the controller to the USB port to a computer. A controller with no USB port (e.g. XSEL) can be connected to the USB port of a computer by connecting an RS232C cable to the USB cable via a USB adapter.
(See PC software IA-101-X-USBMW)

Model CB-SEL-USB030 (Cable length: 3m)



Adapter Cable

Features An adapter cable to connect the D-sub 25-pin connector from the teaching pendant or a PC to the teaching connector (half-pitch) of the PSEL controller.

Model CB-SEL-SJ002 (Cable length: 0.2m)

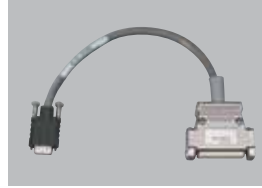

Spare Parts

When you need spare parts after purchasing the product, such as when replacing a cable, refer to the list of models below.

Motor robot cable

Model CB-RCP2-MA

** The standard cable for the motor cable is the robot cable.

* Enter the cable length (L) into . Compatible to a maximum of 20 meters.
Ex.: 080 = 8m

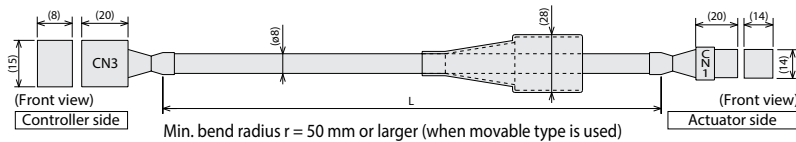

I-1318119-3 (AMP)	CN3 M cable			CN1			SLP-06V (JST)
	Color	Signal	Pin No.	Color	Signal	Pin No.	
Orange	A	A1	1	A	Yellow	1	
Gray	VMM	A2	2	VMM	Gray	2	
White	B	A3	3	A	Orange	3	
Yellow	A	B1	4	B	Orange (Black 1)	4	
Pink	VMM	B2	5	VMM	Pink	5	
Orange (Black 1)	B	B3	6	B	White	6	

Encoder cable/Encoder robot cable

Model CB-RCP2-PB / CB-RCP2-PB -RB

* The standard cable for the encoder cable is a normal cable. A robot cable can be specified as an option.

* Enter the cable length (L) into . Compatible to a maximum of 20 meters.
Ex.: 080 = 8m

Min. bend radius r = 50mm or larger (when movable type is used)
* Only robot cable is to be used in a cable track.

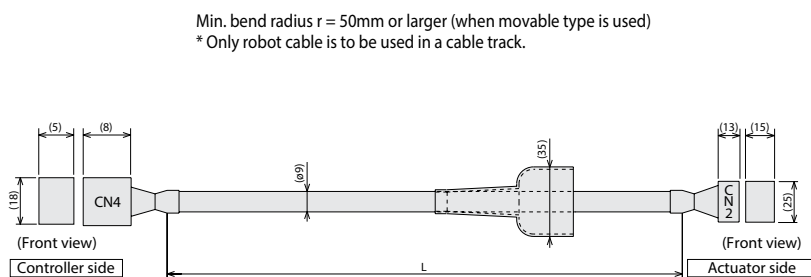

Cable color	Signal	Pin No.	C N 4		C N 2	
			Standard Cable	Robot Cable	Standard Cable	Robot Cable
Blue (Red 1)	LS +	16	1	E N A	Brown	Light Gray (Red 1)
Orange (Black 2)	LS -	15	2	E N A	Green	Light Gray (Red 1)
White	B K +	14	3	E N B	Purple	White (Black 1)
Red	Orange (Red 2)	13	4	E N B	Pink	White (Black 1)
Gray	Orange (Red 1)	12	5	—	—	—
Brown	Light Gray (Black 1)	11	6	—	—	—
Green	Light Gray (Red 1)	10	7	—	—	—
Purple	White (Black 1)	9	8	—	—	—
Pink	White (Red 1)	8	9	—	—	—
—	—	7	10	V B B	Blue	Pink (Black 1)
Yellow	Yellow (Black 1)	6	11	V P S	Yellow	Pink (Red 1)
Orange	Pink (Black 1)	5	12	—	—	—
Blue	Pink (Black 1)	4	13	LS +	Blue (Red 1)	Orange (Black 2)
—	—	3	14	LS -	White	Orange (Red 2)
—	—	2	15	—	—	—
—	—	1	16	B K +	Red	Orange (Red 1)
Ground	Ground	FG	17	B K -	Gray	Orange (Red 1)
			18	F. G	Ground	Ground

Motor-Encoder Integrated Cable for RCP3

Model CB-PCS-MPA

* Enter the cable length (L) into . Compatible to a maximum of 20 meters.
Ex.: 080 = 8m

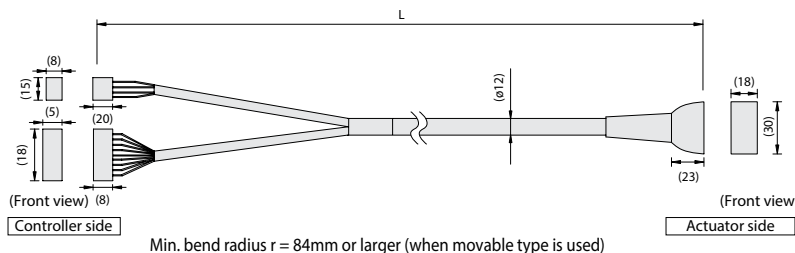

Signal	Pin Number	Wire color	Pin Number	Signal
A	B1	Black	A1	A
VMM	A2	White	B1	VMM
A	A1	Red	A2	A
B	B3	Green	B2	B
VMM	B2	Yellow	A3	VMM
/B	A3	Brown	B3	/B
			B4	NC
			A4	NC
BK+	14	Pink (Red ●)	A5	BK+
BK-	13	Pink (Blue ●)	B5	BK-
LS+	16	White (Red ●)	A6	LS+
LS-	15	White (Blue ●)	B6	LS-
A+	12	Orange (Red ●)	A7	A+
A-	11	Orange (Blue ●)	B7	A-
B+	10	Gray (Red ●)	A8	B+
B-	9	Gray (Blue ●)	B8	B-
NC	8		A9	NC
VPS	7	Orange (Blue ● Contiguous)	B9	VPS
VCC	6	Gray (Red ● Contiguous)	A10	VCC
GND	5	Gray (Blue ● Contiguous)	B10	GND
NC	4		A11	NC
FG	1	Shield	B11	FG

I/O Flat Cable

Model CB-DS-PIO

* Enter the cable length (L) into . Compatible to a maximum of 10 meters.
Ex.: 080 = 8m

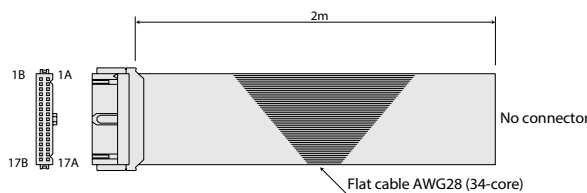

Pin No.	Color	Wire	Pin No.	Color	Wire
1A	Brown 1	Flat cable crimped	9B	Gray 2	Flat cable crimped
1B	Red 1		10A	White 2	
2A	Orange 1		10B	Black 2	
2B	Yellow 1		11A	Brown-3	
3A	Green 1		11B	Red 3	
3B	Blue 1		12A	Orange 3	
4A	Purple 1		12B	Yellow 3	
4B	Gray 1		13A	Green 3	
5A	White 1		13B	Blue 3	
5B	Black 1		14A	Purple 3	
6A	Brown-2		14B	Gray 3	
6B	Red 2		15A	White 3	
7A	Orange 2		15B	Black 3	
7B	Yellow 2		16A	Brown-4	
8A	Green 2		16B	Red 4	
8B	Blue 2		17A	Orange 4	
9A	Purple 2		17B	Yellow 4	

ASEL Controller

- Controller
- PMEC
AMEC
- PSEP
ASEP
DSEP
- MSEP
- ERC3
- ERC2
- PCON
-CA
- PCON
- ACON
- SCON
-CA
- MSCON
- PSEL
- ASEL**
- SSEL
- XSEL
- PS-24

ASEL



Program controller
For RCA2/RCA

List of models

Program controller for operating RCA2/RCA Series actuators. One unit can handle various controls.

Type		CS	
Name		Program mode	Positioner mode
External view			
Description		Both the actuator operation and communication with external equipment can be handled by a single controller. When two axes are connected, arc interpolation, path operations, and synchronization can be performed.	Up to 1,500 positioning points are supported. Push-motion operation and teaching operation are also possible.
Position Points		1,500 points	
Standard Price	1 axis	Incremental	—
		Absolute	—
	2 axes	Incremental	—
		Absolute	—

Model

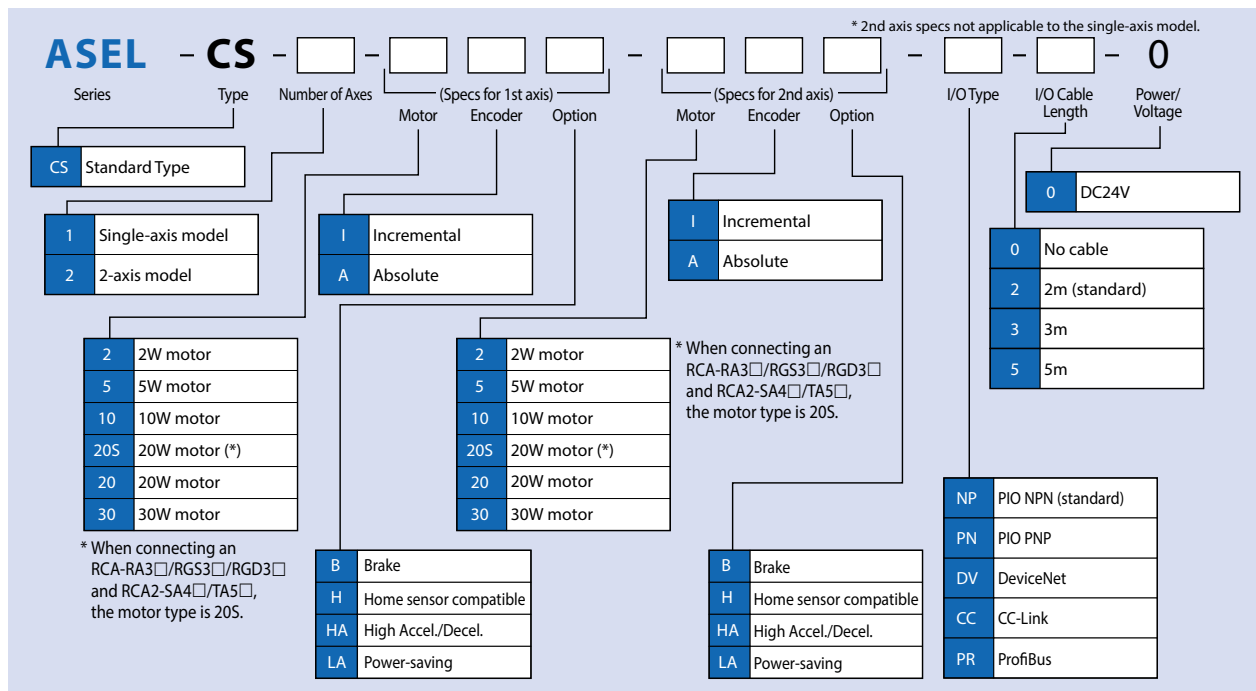

675 ASEL

System Configuration

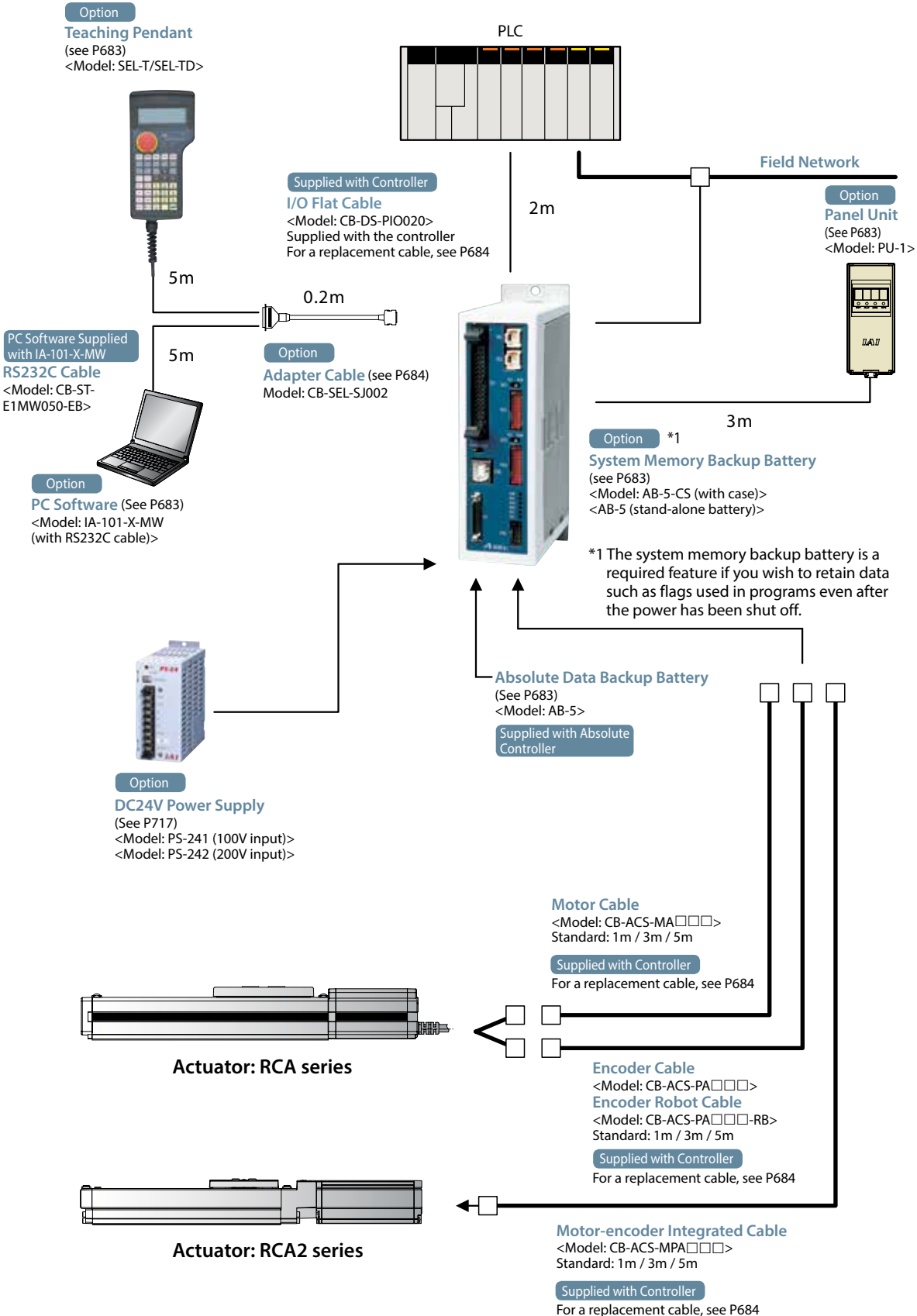

- PMEC AMEC
- PSEP ASEP DSEP
- MSEP
- ERC3
- ERC2
- PCON -CA
- PCON
- ACON
- SCON -CA
- MSCON
- PSEL
- ASEL
- SSEL
- XSEL
- PS-24

Pulse Motor

Servo Motor (24V)

Servo Motor (200V)

Linear Servo Motor

- Controller
- PMEC
AMEC
- PSEP
ASEP
DSEP
- MSEP
- ERC3
- ERC2
- PCON
-CA
- PCON
- ACON
- SCON
-CA
- MCON
- PSEL
- ASEL**
- SSEL
- XSEL
- PS-24
- Pulse Motor
- Servo Motor (24V)
- Servo Motor (200V)
- Linear Servo Motor

I/O Specification

Input section External input specifications

Item	Specifications
Input voltage	DC24V ±10%
Input current	7mA/circuit
ON/OFF voltage	ON voltage (min.) NPN : DC16V / PNP : DC8V OFF voltage (max.) NPN : DC5V / PNP : DC19V
Isolation method	Photocoupler

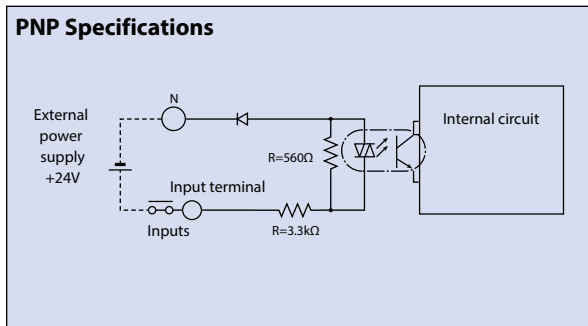
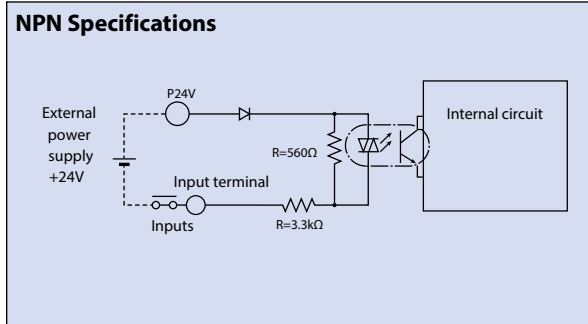

Output section External output specifications

Item	Specifications
Load Voltage	DC24V
Max. load current	100mA / 1 point 400mA / 8 points in total
Residual voltage (Max.)	Max 0.1mA / 1 point
Isolation method	Photocoupler

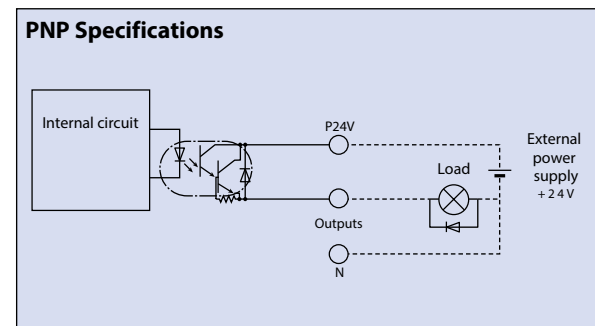
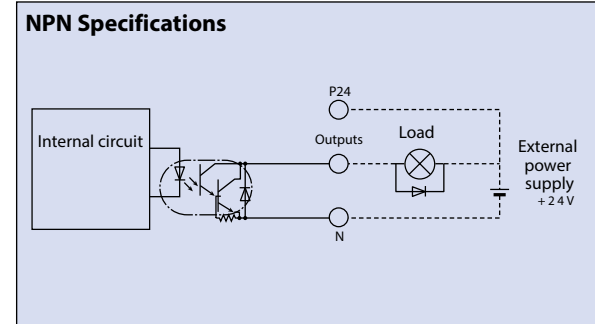

Explanation of I/O Signal Functions

Two modes can be selected for the ASEL controller: "Program Mode," in which the actuator is operated by entering a program, and "Positioner Mode," in which PLC signals are received and the actuator is moved to designated positions. The Positioner Mode has the five input patterns listed below to enable various applications.

Control Function by Type

Operation mode		Features
Program mode		Various operations including linear/arc interpolation operation, path operation ideal for coating processes, etc., arch-motion operation and palletizing operation can be performed using the Super SEL language that lets you program complex control actions using simple commands.
Positioner mode	Standard mode	This is the basic mode from which operations can be conducted by designating position numbers and inputting the start signal. Push-motion operation and teaching operation are also possible.
	Product Change mode	Multiple work parts of the same shape with slightly different hole positions can be handled using movement commands to the same position numbers by simply changing the product type number.
	2-axis independent mode	With a 2-axis controller, each axis can be commanded and operated separately.
	Teaching mode	In this mode, the slider (rod) moves based on an external signal, when the actuator is stopped, the current location can be registered as position data.
	DS-S-C1 Compatible mode	If you were using a DS-S-C1 controller, you can replace it with a ASEL controller without having to change the host programs. *This mode does not ensure actuator compatibility.

677

ASEL

Explanation of I/O Signal Functions

Program mode

Pin Number	Category	Port No.	Program Mode	Functions	Wiring Diagram	
1A	P24	016	24V input	Connect 24V.		
1B			Select Program No. 1	Selects the program number to start. (Input as BCD values to ports 016 to 022)		
2A			017			Select Program No. 2
2B			018			Select Program No. 4
3A	019	Select Program No. 8				
3B	020	Select Program No. 10				
4A	021	Select Program No. 20				
4B	022	Select Program No. 40				
5A	023	CPU reset	Resets the system to the same state as when the power is turned on.			
5B	000	Start	Starts the program selected by ports 016 to 022.			
6A	Input	001	General-purpose input			Waits for external input via program instructions.
6B		002	General-purpose input			
7A		003	General-purpose input			
7B		004	General-purpose input			
8A		005	General-purpose input			
8B		006	General-purpose input			
9A		007	General-purpose input			
9B		008	General-purpose input			
10A		009	General-purpose input			
10B		010	General-purpose input			
11A	011	General-purpose input	Turns off when an alarm occurs. (Contact B) Turns on when the controller starts up normally and is in an operable state.			
11B	012	General-purpose input				
12A	013	General-purpose input				
12B	014	General-purpose input				
13A	015	General-purpose input				
13B	300	Alarm				
14A	301	Ready				
14B	302	General-purpose output		These outputs can be turned ON/OFF as desired via program instructions.		
15A	303	General-purpose output				
15B	304	General-purpose output				
16A	305	General-purpose output				
16B	306	General-purpose output				
17A	307	General-purpose output				
17B	N	0V input	Connect 0V.			

Note: This is for NPN. PNP will be different.

Positioner mode

Pin Number	Category	Port No.	Positioner Standard Mode	Functions	Wiring Diagram	
1A	P24	016	24V input	Connect 24V.		
1B			Position input 10	Specifies the position numbers to move to, using port number 007 to 019 The number can be specified either as BCD or binary.		
2A			017			Position input 11
2B			018			Position input 12
3A	019	Position input 13				
3B	020	-				
4A	021	-				
4B	022	-				
5A	023	Error reset	Resets minor errors. (Severe errors require a restart.)			
5B	000	Start	Starts moving to the selected position.			
6A	001	Home Return	Performs Home Return.			
6B	002	Servo ON	Switches between Servo ON and OFF.			
7A	003	Push	Performs a push motion.			
7B	004	Pause	Pauses the motion when turned OFF, and resumes motion when turned ON.			
8A	005	Cancel	Stops the motion when turned OFF. The remaining motion is canceled.			
8B	006	Interpolation settings	When this signal turned ON for a 2-axis model, the actuator moves by linear interpolation.			
9A	007	Position input 1	Specifies the position numbers to move to, using ports 007 to 019. The number can be specified either as BCD or binary.			
9B	008	Position input 2				
10A	009	Position input 3				
10B	010	Position input 4				
11A	011	Position input 5				
11B	012	Position input 6				
12A	013	Position input 7				
12B	014	Position input 8				
13A	015	Position input 9				
13B	300	Alarm	Turns off when an alarm occurs. (Contact B)			
14A	301	Ready	Turns on when the controller starts up normally and is in an operable state.			
14B	302	Positioning complete	Turns on when the movement to the destination is complete.			
15A	303	Home Return complete	Turns on when the home return operation is complete.			
15B	304	Servo ON output	Turns on when servo is ON.			
16A	305	Pushing complete	Turns on when a push motion is complete.			
16B	306	System battery error	Turns on when the system battery runs low (warning level).			
17A	307	Absolute encoder battery error	Turns on when the battery for the absolute encoder runs low (warning level).			
17B	N	0V input	Connect 0V.			

Note: This is for NPN. PNP will be different.

- Controller
- PMEC
- AMEC
- PSEP
- ASEP
- DSEP
- MSEP
- ERC3
- ERC2
- PCON
- CA
- PCON
- ACON
- SCON
- CA
- MSCON
- PSEL
- ASEL
- SSEL
- XSEL
- PS-24
- Pulse Motor
- Servo Motor (24V)
- Servo Motor (200V)
- Linear Servo Motor

Explanation of I/O Signal Functions

Positioner, Product-Type Change Mode

Pin Number	Category	Port No.	Positioner Product Type Change Mode	Functions		
1A	P24	016	24V input	Connect 24V.		
1B			Position/Product Type Input 10	Specifies the position numbers to move to, and the product type numbers, using ports 007 to 022. The position and product type numbers are assigned by parameter settings. The number can be specified either as BCD or binary.		
2A			Position/Product Type Input 11			
2B			Position/Product Type Input 12			
3A			Position/Product Type Input 13			
3B			Position/Product Type Input 14			
4A			Position/Product Type Input 15			
4B			Position/Product Type Input 16			
5A			023		Error reset	Resets minor errors. (Severe errors require a restart.)
5B			000		Start	Starts moving to the selected position.
6A			001		Home Return	Performs Home Return.
6B			002		Servo ON	Switches between Servo ON and OFF.
7A			003		Push	Performs a push motion.
7B			004		Pause	Pauses the motion when turned OFF, and resumes motion when turned ON.
8A			005		Cancel	Stops the motion when turned OFF. The remaining motion is canceled.
8B			006		Interpolation settings	When this signal is turned ON for a 2-axis model, the actuator moves by linear interpolation.
9A			007		Position/Product Type Input 1	Specifies the position numbers to move to, and the product type numbers, using ports 007 to 022. The position and product type numbers are assigned by parameter settings. The number can be specified either as BCD or binary.
9B	008	Position/Product Type Input 2				
10A	009	Position/Product Type Input 3				
10B	010	Position/Product Type Input 4				
11A	011	Position/Product Type Input 5				
11B	012	Position/Product Type Input 6				
12A	013	Position/Product Type Input 7				
12B	014	Position/Product Type Input 8				
13A	015	Position/Product Type Input 9				
13B	Output	300	Alarm	Turns off when an alarm occurs (Contact B)		
14A		301	Ready	Turns on when the controller starts up normally and is in an operable state.		
14B		302	Positioning complete	Turns on when the movement to the destination is complete.		
15A		303	Home Return complete	Turns on when the home return operation is complete.		
15B		304	Servo ON output	Turns on when servo is ON.		
16A		305	Pushing complete	Turns on when a push motion is complete.		
16B		306	System battery error	Turns on when the system battery runs low (warning level).		
17A		307	Absolute encoder battery error	Turns on when the battery for the absolute encoder runs low (warning level).		
17B		N	0V input	Connect 0V.		

Wiring Diagram

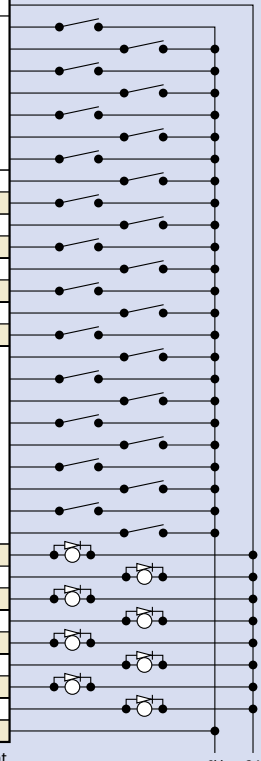

Note: This is for NPN. PNP will be different.

Positioner, 2-axis Independent Mode

Pin Number	Category	Port No.	Positioner 2-axis Independent Mode	Functions		
1A	P24	016	24V input	Connect 24V.		
1B			Position input 7	Specifies the position numbers to move to, using ports 010 to 022. The position numbers on the 1st and 2nd axes are assigned by parameter settings. The number can be specified either as BCD or binary.		
2A			Position input 8			
2B			Position input 9			
3A			Position input 10			
3B			Position input 11			
4A			Position input 12			
4B			Position input 13			
5A			023		Error reset	Resets minor errors. (Severe errors require a restart.)
5B			000		Start 1	Starts movement to the selected position number on the 1st axis.
6A			001		Home Return 1	Performs home return on the 1st axis.
6B			002		Servo ON 1	Switches between servo ON and OFF for the 1st axis.
7A			003		Pause 1	Pauses the motion on 1st axis when turned OFF, and resumes motion when turned ON.
7B			004		Cancel 1	Cancels the movement on the 1st axis.
8A			005		Start 2	Starts the movement to the selected position number on the 2nd axis.
8B			006		Home Return 2	Performs home return on the 2nd axis.
9A			007		Servo ON 2	Switches between servo ON and OFF for the 2nd axis.
9B	008	Pause 2	Pauses the motion on 2nd axis when turned OFF, and resumes when turned ON.			
10A	009	Cancel 2	Cancels the movement on the 2nd axis.			
10B	010	Position input 1	Specifies the position numbers to move to, using ports 010 to 022. The position numbers on the 1st and 2nd axes are assigned by parameter settings. The number can be specified either as BCD or binary.			
11A	011	Position input 2				
11B	012	Position input 3				
12A	013	Position input 4				
12B	014	Position input 5				
13A	015	Position input 6				
13B	Output	300	Alarm	Turns off when an alarm occurs (Contact B)		
14A		301	Ready	Turns on when the controller starts up normally and is in an operable state.		
14B		302	Positioning complete 1	Turns on when the movement to the specified position on the 1st axis is complete.		
15A		303	Home Return complete 1	Turns on when home return on the 1st axis is complete.		
15B		304	Servo ON output 1	Turns on when the 1st axis is in a servo ON state.		
16A		305	Positioning complete 2	Turns on when the movement to the specified position on the 2nd axis is complete.		
16B		306	Home Return complete 2	Turns on when home return on the 2nd axis is complete.		
17A		307	Servo ON output 2	Turns on when the 2nd axis is in a servo ON state.		
17B	N	0V input	Connect 0V.			

Wiring Diagram

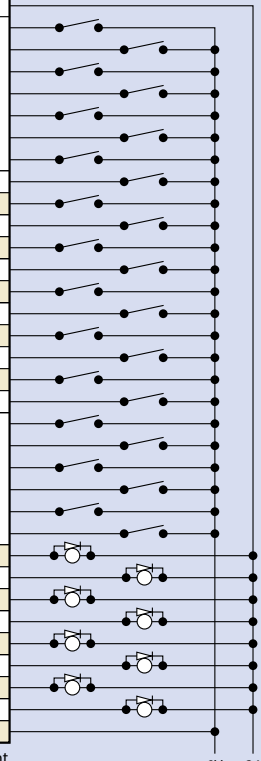

Note: This is for NPN. PNP will be different.

Explanation of I/O Signal Functions

Positioner, Teaching Mode

Pin Number	Category	Port No.	Positioner Teaching Mode	Functions			
1A	P24	016	24V input	Connect 24V.			
1B			JOG- on 1st axis	While the signal is on, the 1st axis is moved in the - (negative) direction.			
2A			JOG+ on 2nd axis	While the signal is on, the 2nd axis is moved in the + (positive) direction.			
2B			JOG- on 2nd axis	While the signal is on, the 2nd axis is moved in the - (negative) direction.			
3A			Specify inching (0.01mm)	019	Specify inching (0.01mm)	Specifies how much to move during inching. (Total of the values specified for ports 019 to 022)	
3B							Specify inching (0.1mm)
4A							Specify inching (0.5mm)
4B			Specify inching (1mm)	022	Specify inching (1mm)		
5A			023	Error reset	Resets minor errors. (Severe errors require a restart.)		
5B			000	Start	Starts moving to selected position.		
6A			001	Servo ON	Switches between Servo ON and OFF.		
6B			002	Pause	Pauses the motion when turned OFF, and resumes motion when turned ON.		
7A			Input	003	Position input 1	Ports 003 to 013 are used to specify the position number to move, and the position number for inputting the current position. When the teaching mode setting on port 014 is in the ON state, the current value is written to the specified position number.	
7B				004	Position input 2		
8A				005	Position input 3		
8B				006	Position input 4		
9A				007	Position input 5		
9B	008	Position input 6					
10A	009	Position input 7					
10B	010	Position input 8					
11A	011	Position input 9					
11B	012	Position input 10					
12A	013	Position input 11					
12B	014	Teaching mode setting					
13A	015	JOG+ on 1st axis	While the signal is input, the 1st axis is moved in the + (positive) direction.				
13B	300	Alarm	Turns off when an alarm occurs. (Contact B)				
14A	301	Ready	Turns on when the controller starts up normally and is in an operable state.				
14B	302	Positioning complete	Turns on when the movement to the destination is complete.				
15A	303	Home return complete	Turns on when the home return operation is complete.				
15B	304	Servo ON output	Turns on when servo is ON.				
16A	305	-	-				
16B	306	System battery error	Turns on when the system battery runs low (warning level).				
17A	307	Absolute encoder battery error	Turns on when the battery for the absolute encoder runs low (warning level).				
17B	N	0V input	Connect 0V.				

Wiring Diagram

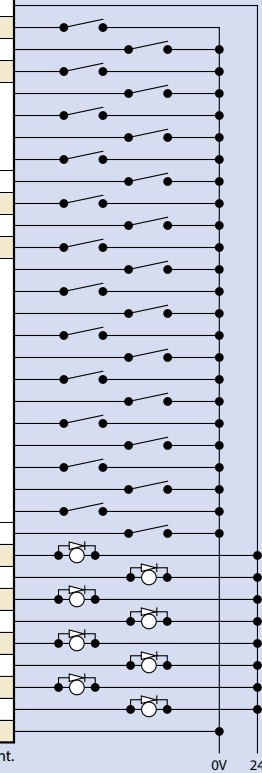

Note: This is for NPN. PNP will be different.

Positioner, DS-S-C1 Compatible Mode

Pin Number	Category	Port No.	Positioner DS-S-C1 Compatible Mode	Functions		
1A	P24	016	24V input	Connect 24V.		
1B			Position No. 1000	(Same as ports 004 through 015)		
2A			017	-		
2B			018	-		
3A			019	-		
3B			020	-		
4A			021	-		
4B			022	-		
5A			023	CPU reset	Resets the system to the same state as when the power is turned on.	
5B			000	Start	Starts moving to selected position.	
6A			001	Hold (Pause)	Pauses the motion when turned ON, and resumes when turned OFF.	
6B			002	Cancel	Stops the motion when turned ON. The remaining motion is canceled.	
7A			Input	003	Interpolation settings	Ports 004 through 016 are used to specify the position number to move. The numbers are specified as BCD.
7B				004	Position No. 1	
8A				005	Position No. 2	
8B				006	Position No. 4	
9A				007	Position No. 8	
9B	008	Position No. 10				
10A	009	Position No. 20				
10B	010	Position No. 40				
11A	011	Position No. 80				
11B	012	Position No. 100				
12A	013	Position No. 200				
12B	014	Position No. 400				
13A	015	Position No. 800				
13B	300	Alarm	Turns off when an alarm occurs. (Contact A)			
14A	301	Ready	Turns on when the controller starts up normally and is in an operable state.			
14B	302	Positioning complete	Turns on when the movement to the destination is complete.			
15A	303	-	-			
15B	304	-	-			
16A	305	-	-			
16B	306	System battery error	Turns on when the system battery runs low (warning level).			
17A	307	Absolute encoder battery error	Turns on when the battery for the absolute encoder runs low (warning level).			
17B	N	0V input	Connect 0V.			

Wiring Diagram

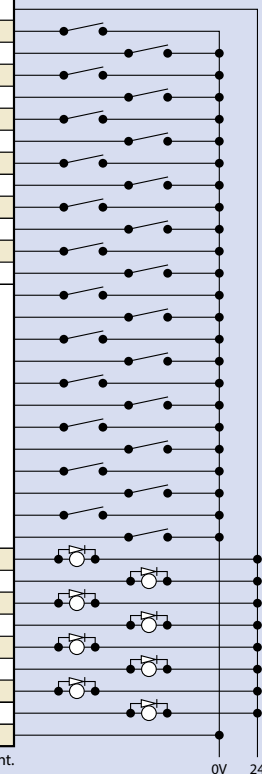

Note: This is for NPN. PNP will be different.

PMEC
AMEC

PSEP
ASEP
DSEP

MSEP

ERC3

ERC2

PCON
-CA

PCON

ACON

SCON
-CA

MSCON

PSEL

ASEL

SSEL

XSEL

PS-24

Pulse
Motor

Servo
Motor
(24V)

Servo
Motor
(200V)

Linear
Servo
Motor

- Controller
- PMEC
AMEC
- PSEP
ASEP
DSEP
- MSEP
- ERC3
- ERC2
- PCON
-CA
- PCON
- ACON
- SCON
-CA
- MSCON
- PSEL
- ASEL**
- SSEL
- XSEL
- PS-24
- Pulse Motor
- Servo Motor (24V)
- Servo Motor (200V)
- Linear Servo Motor

Table of Specifications

	Item	Specifications
Basic Specifications	Connected actuator	RCA/RCA2 Series Actuator
	Input Voltage	DC24V ±10%
	Power Supply Capacity	Control power supply (Max. 1.2A) + motor power supply (See the table below)
	Dielectric strength voltage	DC500V 10MΩ or higher
	Withstand voltage	AC500V 1 min.
	Rush current	Max. 30A
Control specification	Vibration resistance	XYZ directions 10 to 57Hz, One side amplitude: 0.035mm (continuous), 0.075mm (intermittent) 58 to 150 Hz 4.9 m/s ² (continuous), 9.8 m/s ² (intermittent)
	Number of control axes	1 axis / 2 axis
	Maximum total output of connected axis	60W (30W + 30W)
	Position detection method	Incremental encoder / Absolute encoder
	Speed setting	1mm/sec and up, the maximum depends on actuator specifications
	Acceleration setting	0.01G and up, the maximum depends on the actuator
Program	Operating method	Program operation / Positioner operation (switchable)
	Programming language	Super SEL language
	Number of programs	64 programs
	Number of program steps	2,000 steps
	Number of multi-tasking programs	8 points
	Positioning Points	1,500 points
Communication	Data memory device	FLASHROM (A system-memory backup battery can be added as an option)
	Data input method	Teaching pendant or PC software
	Number of I/O	24 input points / 8 output points (NPN or PNP selectable)
	I/O power	Externally supplied 24VDC ± 10%
	PIO cable	CB-DS-PIO□□□ (supplied with the controller)
	Serial communications function	RS232C (D-Sub Half-pitch connector) / USB connector
General specifications	Field Network	DeviceNet, CC-Link, ProfiBus
	Motor Cable	CB-ACS-MA□□□(Max. 20m)
	Encoder cable	CB-ACS-PA□□□(Max. 20m)
	Protection function	Motor overcurrent, Motor driver temperature check, Overload check, Encoder open-circuit check Soft limit over, system error, battery error, etc.
	Ambient operating humidity and temperature	0 to 40°C 10 to 95% (non-condensing)
	Ambient atmosphere	Free from corrosive gases. In particular, there shall be no significant dust.
General specifications	Protection class	IP20
	Weight	Approx. 450g
	External dimensions	43 mm (W) x 159 mm (H) x 110 mm (D)

Motor power supply capacity (Note1)	Actuator type	1-Axis specification				2-Axis specification				
		Standard specifications/high acceleration and deceleration model		Power-saving		Standard specifications/high acceleration and deceleration model		Power-saving		
		Rated	Max. (Note2)	Rated	Max. (Note3)	Rated	Max. (Note2)	Rated	Max. (Note3)	
	RCA RCA2	10W, 20W [Model symbol: 20]	1.3A	4.4A	1.3A	2.5A	2.6A	8.8A	2.6A	5.0A
		30W	1.3A	4.4A	1.3A	2.2A	2.6A	8.8A	2.6A	4.4A
		20W [Model symbol: 20S] SA4, RA3, TA5 type dedicated	1.7A	5.1A	1.7A	3.4A	3.4A	10.2A	3.4A	6.8A
	RCL	2W	0.8A	4.6A	—	—	1.6A	9.2A	—	—
		5W	1.0A	6.4A	—	—	2.0A	12.8A	—	—
		10W	1.3A	6.4A	—	—	2.6A	12.8A	—	—

(Note 1) For both 1-axis and 2-axis specifications, approx. 30.0A inrush current flows for 5 ms when the control power supply is turned on.
 (Note 2) Max. current at accelerating/decelerating
 (Note 3) Current reaches the maximum when detecting the servo motor excitation phase at the first servo on after the power is on. (Normal: Approx. 1 to 2 sec., Max: 10 sec)

External Dimensions

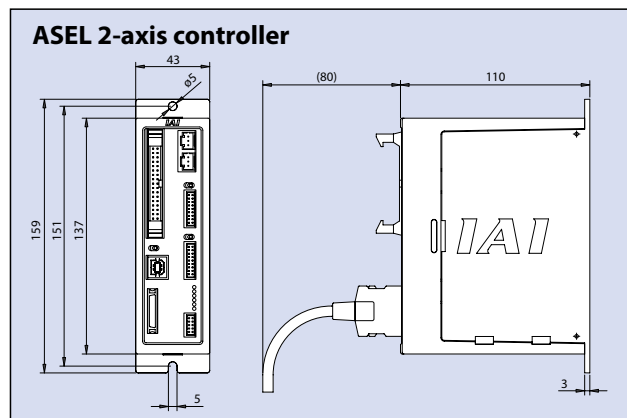
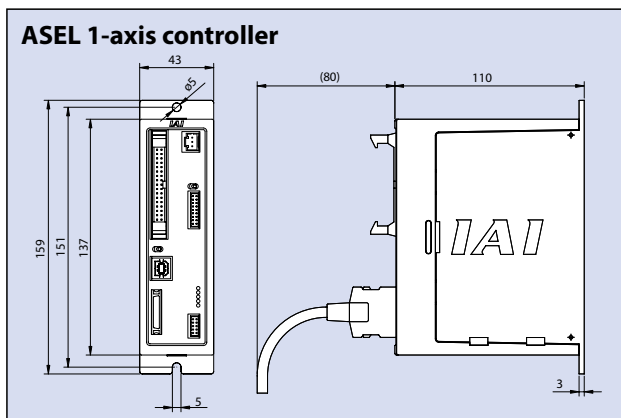

681

ASEL

Name of Each Part

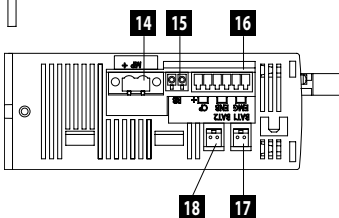
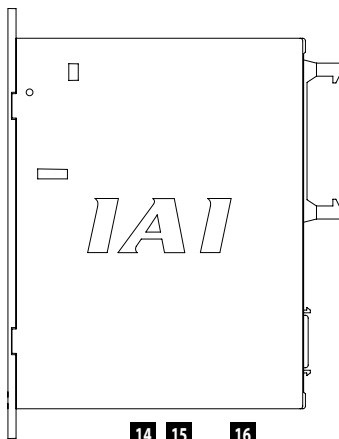
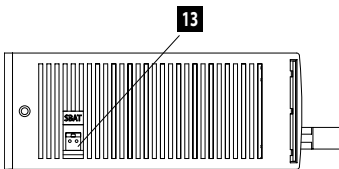
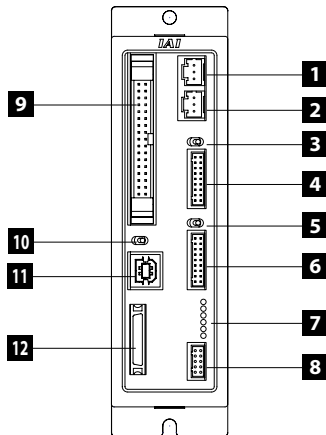

1 Motor connector for axis 1

Connect the motor cable of the axis 1 actuator.

2 Motor connector for axis 2

Connect the motor cable of the axis 2 actuator.

3 Brake switch for axis 1

This switch is used to release the axis brake. Setting it to the left position (RLS side) forcibly releases the brake, while setting it to the right position (NOM side) causes the controller to automatically control the brake.

4 Encoder connector for axis 1

Connect the encoder cable of the axis 1 actuator.

5 Brake switch for axis 2

This switch is used to release the axis brake. Setting it to the left position (RLS side) forcibly releases the brake, while setting it to the right position (NOM side) causes the controller to automatically control the brake.

6 Encoder connector for axis 2

Connect the encoder cable of the axis 2 actuator.

7 Status indicator LEDs

These LEDs are used to indicate the operating condition of the controller.

The LED status indicators are as follows:

- PWR : Power is input to controller.
- RDY : The controller is ready to perform program operation.
- ALM : The controller is abnormal.
- EMG : An emergency stop is actuated and the drive source is cut off.
- SV1 : The axis 1 actuator servo is on.
- SV2 : The axis 2 actuator servo is on.

8 Panel unit connector

A connector for the panel unit (optional) that displays the controller status and error codes.

9 I/O Connector

A connector for interface I/Os.

34-pin flat cable connector for DIO (24IN/8OUT) interface.

I/O power is also supplied to the controller via this connector (Pin No. 1 and No. 34).

10 Mode switch

This switch is used to specify the running mode of the controller. The left position indicates the MANU (manual operation) mode, while the right position indicates the AUTO (automatic operation) mode. Teaching can only be performed in manual operation, and automatic operation using external I/Os is not possible in the MANU mode.

11 USB connector

A connector for PC connection via USB. If the USB connector is connected, the TP connector is disabled and all communication inputs to the TP connector are cut off.

12 Teaching pendant connector

A half-pitch I/O 26-pin connector that connects a teaching pendant when the running mode is MANU. A special conversion cable is needed to connect a conventional Dsub, 25-pin connector.

13 System-memory backup battery connector

If you wish to retain the various data recorded in the SRAM of the controller even after the power is cut off, connect the necessary battery to this connector. This battery is installed externally to the unit. The controller does not come standard with the battery (Option).

14 Motor power input connector

This connector is used to input the motor power. It consists of a 2-pin, 2-piece connector by Phoenix Contact.

15 External regenerative resistor connector

A connector for the regenerative resistor that must be connected when the built-in regenerative resistor alone does not offer sufficient capacity in high-acceleration/ high-load operation, etc.

Whether or not an external regenerative resistor is necessary depends on the conditions of your specific application such as the axis configuration.

16 Control power/System input connector

This connector is used to connect the control power input, emergency stop switch, and enable switch. It consists of a Phoenix Contact 6-pin 2-piece connector.

17 Absolute-data backup battery connector for axis 1

A connector for the battery that backs up absolute data when the actuator uses an absolute encoder. Secure installation of the battery is the customer's responsibility.

18 Absolute-data backup battery connector for axis 2

A connector for the battery that backs up absolute data when the actuator uses an absolute encoder. Secure installation of the battery is the customer's responsibility.

ASEL Controller

Controller

Options

Teaching Pendant

Features This is a teaching device that provides information on functions such as position input, test runs, and monitoring.

Model

Model	Description	Standard Price
SEL-T-JS	Standard type with adapter cable	—
SEL-TD-JS	Equipped with a deadman switch and adapter cable	—

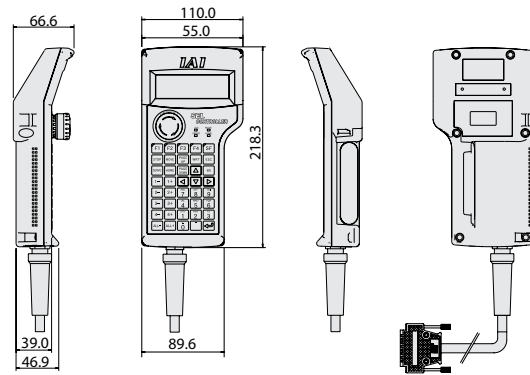

Configuration

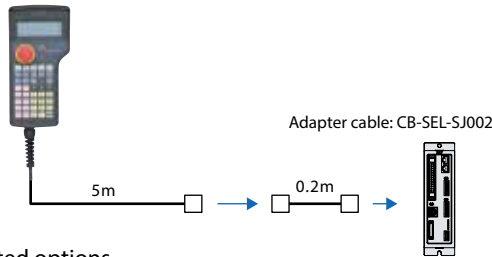

Specifications

Item	SEL-T-JS	SEL-TD-JS
3-position Enable Switch	No	Yes
ANSI/UL standards	Non-compliant	Compliant
CE mark	Compliant	
Display	20 char. x 4 lines	
Ambient Operating Temp./Humidity	0~40°C 10~90% RH (non-condensing)	
Protective structure	IP54	
Weight	Approx. 0.4kg (not incl. cable)	

SEL-T dedicated options

• Wall-mounting hook
Model **HK-1**

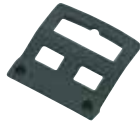

• Strap
Model **STR-1**



PC Software (Windows Only)

Features A startup support software for entering programs/positions, performing test runs, and monitoring. More functions have been added for debugging, and improvements have been made to shorten the start-up time.

Model **IA-101-X-MW-JS** (with RS232C cable + adapter cable)

Configuration

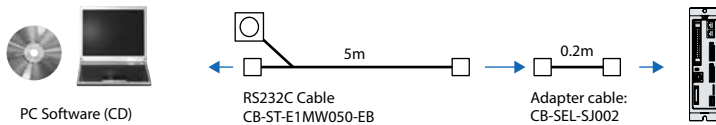

Supported Windows OS:
2000 SP4 or later / XP SP2 or later / Vista / 7

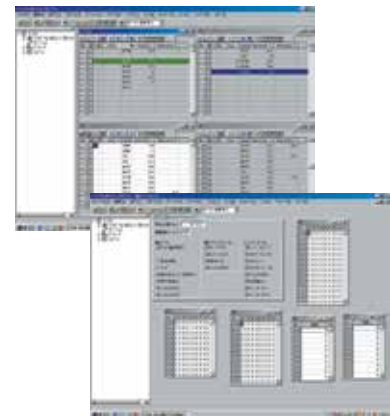

Note:
Only versions 7.0.0.0 and later can be used with the PSEL controller.

Model **IA-101-X-USBS** (with USB cable)

Configuration

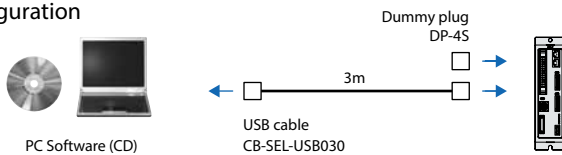

Pulse Motor

Panel Unit

Features Display device that shows the error code from the controller or the currently running program number.

Model **PU-1** (Cable length: 3m)

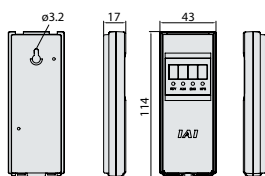

Absolute Data Backup Battery

Features Battery for saving absolute data, when operating an actuator with an absolute encoder. Same as the battery used for system memory backup.

Model **AB-5**



System Memory Backup Battery

Features This battery is required when you are using global flags in the program and you want to retain your data even after the power has been turned OFF.

Model **AB-5-CS** (with case)
AB-5 (Standalone battery)



Servo Motor (24V)

Servo Motor (200V)

Linear Servo Motor

683

ASEL

Options

Dummy Plug

Features When connecting the ASEL controller to a computer with a USB cable, this plug is inserted in the teaching port to shut off the enable circuit.
(Supplied with the PC software IA-101-X-USB)

Model **DP-4S**



USB Cable

Features A cable for connecting the controller to the USB port to a computer. A controller with no USB port (e.g. XSEL) can be connected to the USB port of a computer by connecting an RS232C cable to the USB cable via a USB adapter.
(See PC software IA-101-X-USBMW)

Model **CB-SEL-USB030** (Cable length: 3m)



Adapter Cable

Features An adapter cable to connect the D-sub 25-pin connector from the teaching pendant or a PC to the teaching connector (half-pitch) of the ASEL controller.

Model **CB-SEL-SJ002** (Cable length: 0.2m)



Spare Parts

When you need spare parts after purchasing the product, such as when replacing a cable, refer to the list of models below.

Motor robot cable

Model **CB-ACS-MA** □□□

* The standard motor cable is a robot cable.

* Enter the cable length (L) into □□□. Compatible to a maximum of 20 meters.
Ex.: 080 = 8m

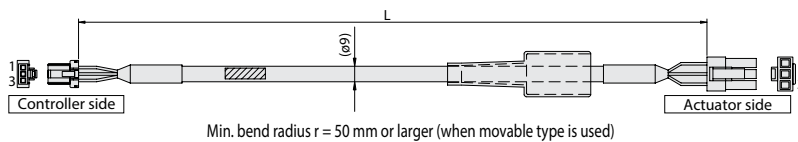

Min. bend radius r = 50 mm or larger (when movable type is used)

Wire	Color	Signal	Pin No.
AWG22 (crimped)	Red	U	1
	White	V	2
	Black	W	3

Pin No.	Signal	Color	Wire
1	ENB	Gray	White/Blue
2	V	Red	White/Red
3	W	Black	White/Black

Encoder cable/Encoder robot cable

Model **CB-ACS-PA** □□□ / **CB-ACS-PA** □□□-**RB**

* The standard cable for the encoder cable is a normal cable. A robot cable can be specified as an option.

* Enter the cable length (L) into □□□. Compatible to a maximum of 20 meters.
Ex.: 080 = 8m

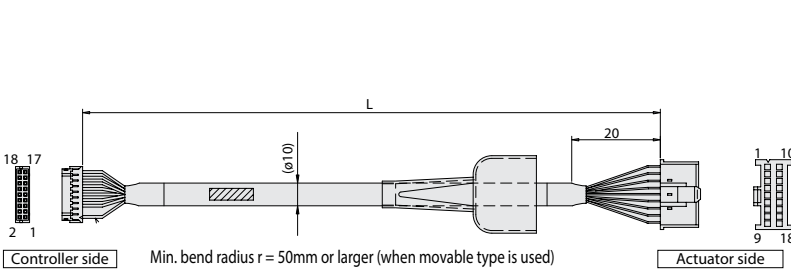

Min. bend radius r = 50mm or larger (when movable type is used)
* Only the robot cable is to be used in a cable track.

CN2				CN1			
Cable color	Signal	Pin No.	Pin No.	Signal	Standard Cable	Robot Cable	Cable color
White/Purple	Blue	LS+	18	1	ENB	Gray	White/Blue
White/Gray	Orange	LS-	17	2	ENB	Red	White/Red
Yellow	Green	BK+	16	3	ENB	Black	White/Black
Blue	Brown	BK-	15	4	ENB	Yellow	White/Black
White/Blue	Gray	ENA	14	5	-	-	-
White/Yellow	Red	ENR	13	6	-	-	-
White/Red	Black	ENB	12	7	LS+	Blue	White/Purple
White/Black	Yellow	ENB	11	8	FG	Ground	Purple
Orange	Pink	ENZ	10	9	ENZ	Pink	Orange
Green	Purple	ENZ	9	10	ENZ	Purple	Green
Purple	White	-	8	11	ENZ	White	Orange
Gray	Blue/red	VPS	7	12	ENZ	Pink	Orange
Red	Orange/White	SV	6	13	VPS	Blue/red	Gray
Black	Green/White	GND	5	14	SV	Orange/White	Red
-	-	-	4	15	GND	Green/White	Black
-	-	-	3	16	LS-	Orange	White/Gray
-	-	-	2	17	BK-	Brown	Blue
-	-	-	1	18	BK+	Brown	Blue
Ground	Ground	FG	1	18	BK+	Green	Yellow

Housing : PHDR-18VR (JST)
Contact : SPHD-001T-P0.5 (JST)

Plug housing : XMP-18V (JST)
Socket contact : 8XA-0011-P0.6 (JST)
Retainer : XMS-09V (JST)

Motor-Encoder Integrated Cable for RCA2

Model **CB-ACS-MPA** □□□

* Enter the cable length (L) into □□□. Compatible to a maximum of 20 meters.
Ex.: 080 = 8m

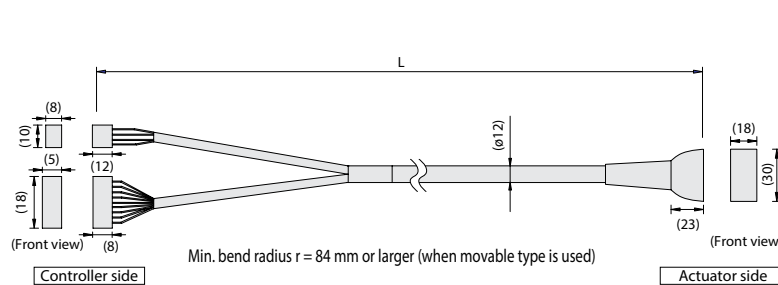

Min. bend radius r = 84 mm or larger (when movable type is used)

Signal	Pin No.	(Wire color)	Pin No.	Signal
A1	1	Red	A1	U
B1	2	Yellow	B1	V
A2	3	Black	A2	W
A3	4	-	A3	NC
B2	5	-	B2	NC
B3	6	-	B3	NC
A4	7	Yellow (Red ●)	A4	BK+
B4	8	Yellow (Blue ●)	B4	BK-
A5	9	Pink (Red ●)	A5	LS+
B5	10	Pink (Blue ●)	B5	LS-
A6	11	White (Red ●)	A6	A+
B6	12	White (Blue ●)	B6	A-
A7	13	Orange (Red ●)	A7	B+
B7	14	Orange (Blue ●)	B7	B-
A8	15	Gray (Red ●)	A8	Z+
B8	16	Gray (Blue ●)	B8	Z-
A9	17	Orange (Blue ● Contiguous)	A9	-
B9	18	Orange (Blue ● Contiguous)	B9	/PS
A10	19	Gray (Red ● Contiguous)	A10	VCC
B10	20	Gray (Blue ● Contiguous)	B10	GND
A11	21	Shield	A11	NC
B11	22	Shield	B11	FG

I/O Flat Cable

Model **CB-DS-PIO** □□□

* Enter the cable length (L) into □□□. Compatible to a maximum of 10 meters.
Ex.: 080 = 8m

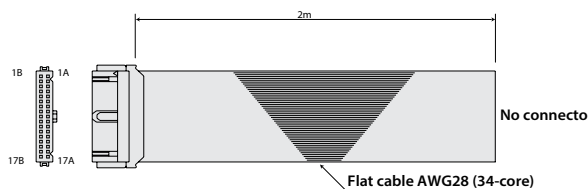

Flat cable AWG28 (34-core)

Pin No.	Color	Wire	Pin No.	Color	Wire
1A	Brown 1		9B	Gray 2	
1B	Red 1		10A	White 2	
2A	Orange 1		10B	Black 2	
2B	Yellow 1		11A	Brown-3	
3A	Green 1		11B	Red 3	
3B	Blue 1		12A	Orange 3	
4A	Purple 1		12B	Yellow 3	
4B	Gray 1		13A	Green 3	
5A	White 1		13B	Blue 3	
5B	Black 1		14A	Purple 3	
6A	Brown-2		14B	Gray 3	
6B	Red 2		15A	White 3	
7A	Orange 2		15B	Black 3	
7B	Yellow 2		16A	Brown-4	
8A	Green 2		16B	Red 4	
8B	Blue 2		17A	Orange 4	
9A	Purple 2		17B	Yellow 4	

SSEL Controller

- Controller
- PMEC
AMEC
- PSEP
ASEP
DSEP
- MSEP
- ERC3
- ERC2
- PCON
-CA
- PCON
- ACON
- SCON
-CA
- MSCON
- PSEL
- ASEL
- SSEL**
- XSEL
- PS-24
- Pulse Motor
- Servo Motor (24V)
- Servo Motor (200V)
- Linear Servo Motor

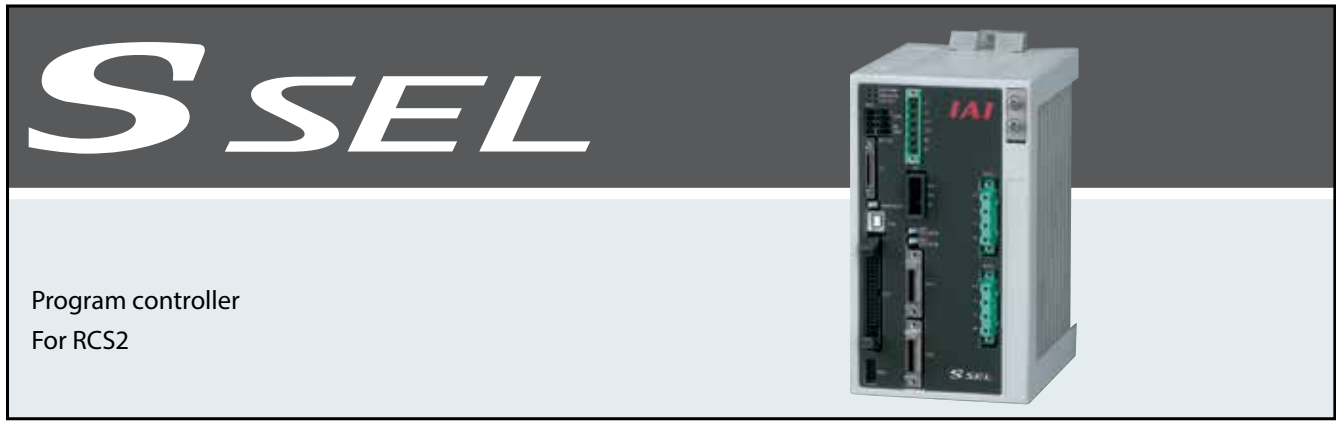

Program controller
For RCS2

List of models

Program controller for operating RCS2 Series actuators. One unit can handle various controls.

Type	CS	
Name	Program mode	Positioner mode
External view		
Description	Both the actuator operation and communication with external equipment can be handled by a single controller. When two axes are connected, arc interpolation, path operations, and synchronization can be performed.	Up to 20,000 positioning points are supported. Push-motion operation and teaching operation are also possible.
Position points	20,000 points	

			20~150W	200W	300~400W	600W	750W
Standard Price	1 axis	Incremental	—	—	—	—	—
		Absolute	—	—	—	—	—
	2 axes	Incremental	—	—	—	—	—
		Absolute	—	—	—	—	—

Models

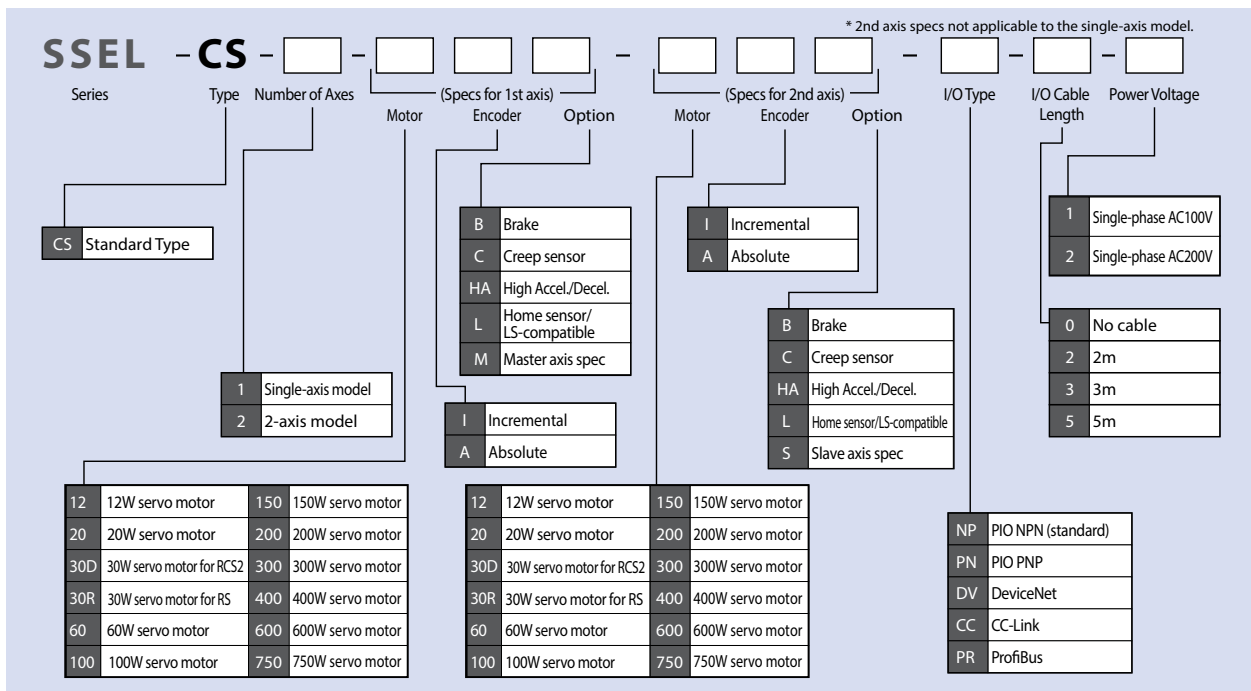

685 SSEL

System Configuration

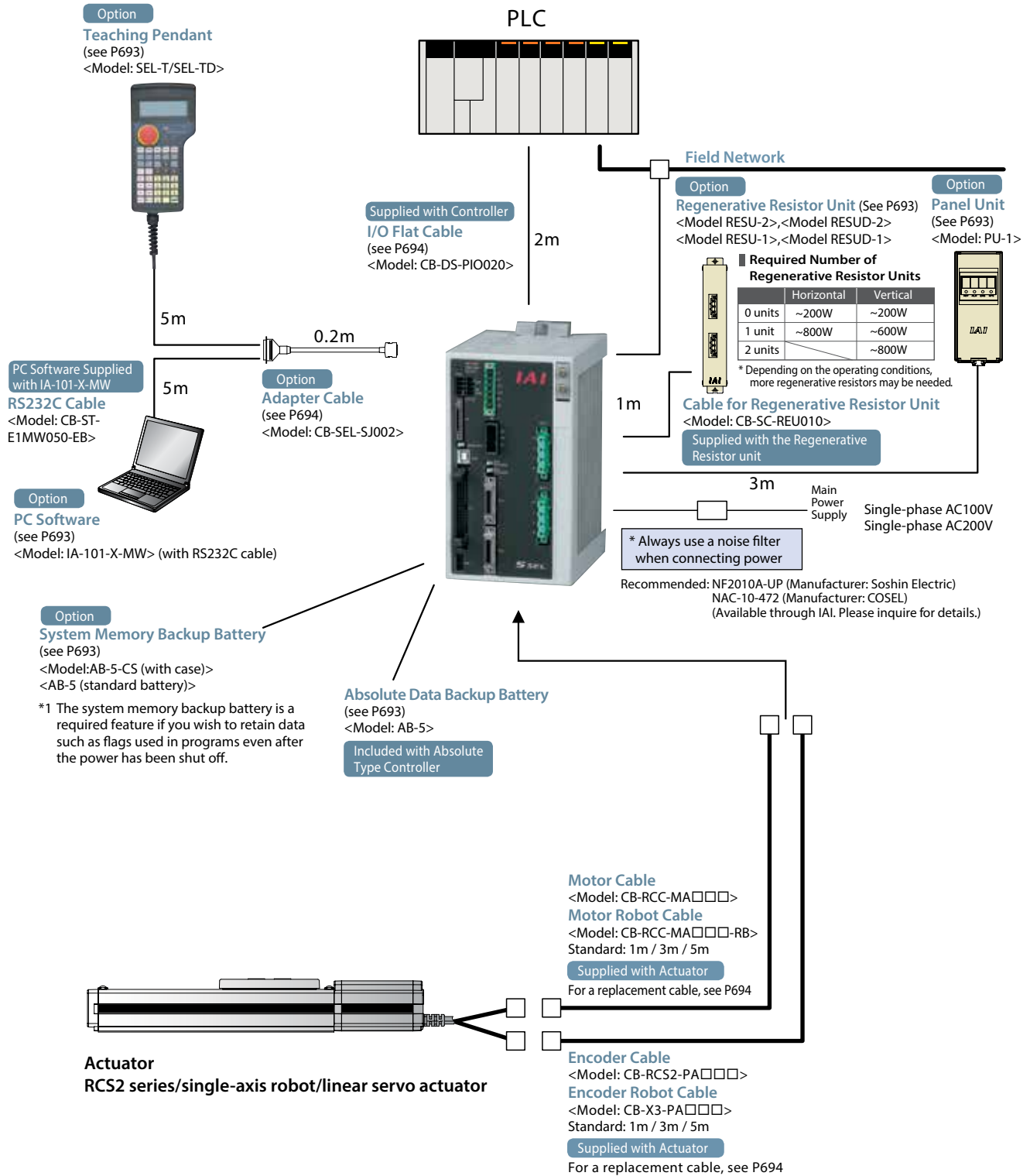

PMEC
AMEC

PSEP
ASEP
DSEP

MSEP

ERC3

ERC2

PCON
-CA

PCON

ACON

SCON
-CA

MSCON

PSEL

ASEL

SSEL

XSEL

PS-24

Pulse
Motor

Servo
Motor
(24V)

Servo
Motor
(200V)

Linear
Servo
Motor

- Controller
- PMEC
- AMEC
- PSEP
- ASEP
- DSEP
- MSEP
- ERC3
- ERC2
- PCON
- CA
- PCON
- ACON
- SCON
- CA
- MSCON
- PSEL
- ASEL
- SSEL**
- XSEL
- PS-24
- Pulse Motor
- Servo Motor (24V)
- Servo Motor (200V)
- Linear Servo Motor

I/O Specification

Input section External input specifications

Item	Specifications
Input voltage	DC24V ±10%
Input current	7mA/circuit
ON/OFF voltage	ON voltage (min.) NPN : DC16V / PNP : DC8V OFF voltage (max.) NPN : DC5V / PNP : DC19V
Isolation method	Photocoupler

NPN Specifications

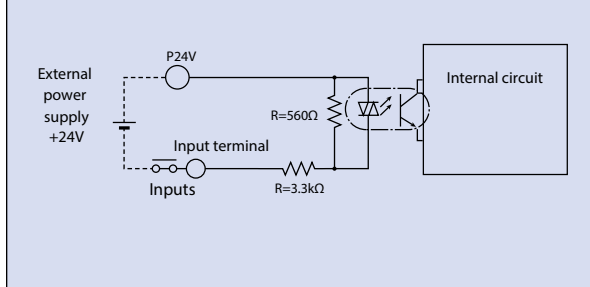

PNP Specifications

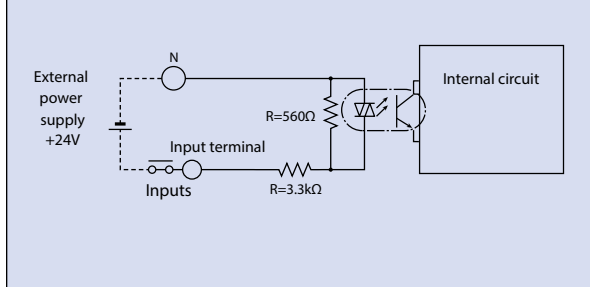

Output section External output specifications

Item	Specifications
Load Voltage	DC24V
Max. load current	100mA / 1 point 400mA / 8 points in total
Residual voltage (Max.)	Max 0.1mA / 1 point
Isolation method	Photocoupler

NPN Specifications

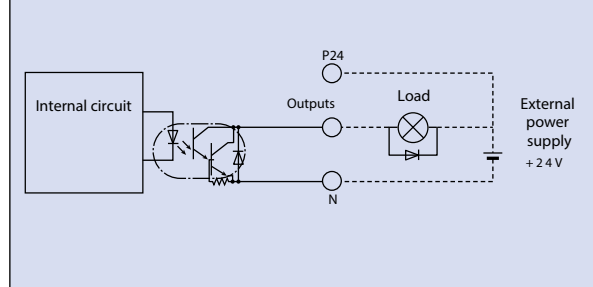

PNP Specifications

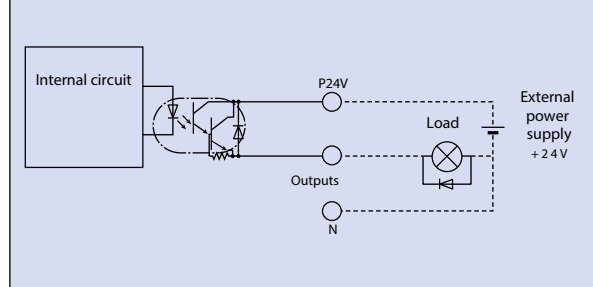

Explanation of I/O Signal Functions

Two modes can be selected for the ASEL controller: "Program Mode," in which the actuator is operated by entering a program, and "Positioner Mode," in which PLC signals are received and the actuator is moved to designated positions. The Positioner Mode has the five input patterns listed below to enable various applications.

Control Function by Type

Operation mode		Features
Program mode		Various operations including linear/arc interpolation operation, path operation ideal for coating processes, etc., arch-motion operation and palletizing operation can be performed using the Super SEL language that lets you program complex control actions using simple commands.
Positioner mode	Standard mode	This is the basic mode from which operations can be conducted by designating position numbers and inputting the start signal. Push-motion operation and teaching operation are also possible.
	Product Change mode	Multiple work parts of the same shape with slightly different hole positions can be handled using movement commands to the same position numbers by simply changing the product type number.
	2-axis independent mode	With a 2-axis controller, each axis can be commanded and operated separately.
	Teaching mode	In this mode, the slider (rod) moves based on an external signal, when the actuator is stopped, the current location can be registered as position data.
DS-S-C1 Compatible mode		If you were using a DS-S-C1 controller, you can replace it with a ASEL controller without having to change the host programs. *This mode does not ensure actuator compatibility.

Explanation of I/O Signal Functions

Program mode

Pin Number	Category	Port No.	Program Mode	Functions	Wiring Diagram	
1A	P24	016	24V input	Connect 24V.		
1B			Select Program No. 1	Selects the program number to start. (Input as BCD values to ports 016 to 022)		
2A			017			Select Program No. 2
2B			018			Select Program No. 4
3A			019			Select Program No. 8
3B			020			Select Program No. 10
4A			021			Select Program No. 20
4B			022			Select Program No. 40
5A	Input	023	CPU reset	Resets the system to the same state as when the power is turned on.		
5B		000	Start	Starts the programs selected by ports 016 to 022.		
6A		001	General-purpose input	Waits for external input via program instructions.		
6B		002	General-purpose input			
7A		003	General-purpose input			
7B		004	General-purpose input			
8A		005	General-purpose input			
8B		006	General-purpose input			
9A		007	General-purpose input			
9B		008	General-purpose input			
10A		009	General-purpose input			
10B	010	General-purpose input				
11A	011	General-purpose input				
11B	012	General-purpose input				
12A	013	General-purpose input				
12B	014	General-purpose input				
13A	Output	015	General-purpose input	These outputs can be turned ON/OFF as desired via program instructions.		
13B		300	Alarm		Turns off when an alarm occurs. (Contact B)	
14A		301	Ready		Turns on when the controller starts up normally and is in an operable state.	
14B		302	General-purpose output			
15A		303	General-purpose output			
15B		304	General-purpose output			
16A		305	General-purpose output			
16B		306	General-purpose output			
17A	307	General-purpose output				
17B	N		0V input	Connect 0V.		

Note: This is for NPN. PNP will be different.

Positioner mode

Pin Number	Category	Port No.	Positioner Standard Mode	Functions	Wiring Diagram	
1A	P24	016	24V input	Connect 24V.		
1B			Position input 10	Specifies the position numbers to move to, using port number 007 to 019 The number can be specified either as BCD or binary.		
2A			017			Position input 11
2B			018			Position input 12
3A			019			Position input 13
3B			020			Position input 14
4A			021			Position input 15
4B			022			Position input 16
5A	Input	023	Error reset	Resets minor errors. (Severe errors require a restart.)		
5B		000	Start	Starts moving to selected position.		
6A		001	Home Return	Performs home return.		
6B		002	Servo ON	Switches between Servo ON and OFF.		
7A		003	Push	Performs a push motion.		
7B		004	Pause	Pauses the motion when turned OFF, and resumes motion when turned ON.		
8A		005	Cancel	Stops the motion when turned OFF. The remaining motion is canceled.		
8B		006	Interpolation setting	When this signal is turned ON for a 2-axis model, the actuator moves by linear interpolation.		
9A		007	Position input 1	Specifies the position numbers to move to, using ports 007 to 019. The number can be specified either as BCD or binary.		
9B		008	Position input 2			
10A		009	Position input 3			
10B	010	Position input 4				
11A	011	Position input 5				
11B	012	Position input 6				
12A	013	Position input 7				
12B	014	Position input 8				
13A	Output	015	Position input 9	These outputs can be turned ON/OFF as desired via program instructions.		
13B		300	Alarm		Turns off when an alarm occurs. (Contact B)	
14A		301	Ready		Turns on when the controller starts up normally and is in an operable state.	
14B		302	Positioning complete		Turns on when the movement to the destination is complete.	
15A		303	Home Return complete		Turns on when the home return operation is complete.	
15B		304	Servo ON output		Turns on when servo is ON.	
16A		305	Pushing complete		Turns on when a push motion is complete.	
16B		306	System battery error		Turns on when the system battery runs low (warning level).	
17A	307	Absolute encoder battery error	Turns on when the battery for the absolute encoder runs low (warning level).			
17B	N		0V input	Connect 0V.		

Note: This is for NPN. PNP will be different.

- Controller
- PMEC
- AMEC
- PSEP
- ASEP
- DSEP
- MSEP
- ERC3
- ERC2
- PCON
- CA
- PCON
- ACON
- SCON
- CA
- MSCON
- PSEL
- ASEL
- SSEL**
- XSEL
- PS-24
- Pulse Motor
- Servo Motor (24V)
- Servo Motor (200V)
- Linear Servo Motor

Explanation of I/O Signal Functions

Positioner, Product-Type Change Mode

Pin Number	Category	Port No.	Positioner Product Type Change Mode	Functions		
1A	Input	P24	24V input	Connect 24V.		
1B			016	Position/Product Type Input 10	Specifies the position numbers to move to, and the product type numbers, using ports 007 to 022. The position and product type numbers are assigned by parameter settings. The number can be specified either as BCD or binary.	
2A			017	Position/Product Type Input 11		
2B			018	Position/Product Type Input 12		
3A			019	Position/Product Type Input 13		
3B			020	Position/Product Type Input 14		
4A			021	Position/Product Type Input 15		
4B			022	Position/Product Type Input 16		
5A			023	Error reset		Resets minor errors. (Severe errors require a restart.)
5B			000	Start		Starts moving to selected position.
6A			001	Home Return		Performs home return.
6B			002	Servo ON	Switches between Servo ON and OFF.	
7A			003	Push	Performs a push motion.	
7B			004	Pause	Pauses the motion when turned OFF, and resumes motion when turned ON.	
8A			005	Cancel	Stops the motion when turned OFF. The remaining motion is canceled.	
8B			006	Interpolation setting	When this signal is turned ON for a 2-axis model, the actuator moves by linear interpolation.	
9A			007	Position/Product Type Input 1	Specifies the position numbers to move to, and the product type numbers, using ports 007 to 022. The position and product type numbers are assigned by parameter settings. The number can be specified either as BCD or binary.	
9B	008	Position/Product Type Input 2				
10A	009	Position/Product Type Input 3				
10B	010	Position/Product Type Input 4				
11A	011	Position/Product Type Input 5				
11B	012	Position/Product Type Input 6				
12A	013	Position/Product Type Input 7				
12B	014	Position/Product Type Input 8				
13A	015	Position/Product Type Input 9				
13B	Output	N	300	Alarm	Turns off when an alarm occurs. (Contact B)	
14A			301	Ready	Turns on when the controller starts up normally and is in an operable state.	
14B			302	Positioning complete	Turns on when the movement to the destination is complete.	
15A			303	Home Return complete	Turns on when the home return operation is complete.	
15B			304	Servo ON output	Turns on when servo is ON.	
16A			305	Pushing complete	Turns on when a push motion is complete.	
16B			306	System battery error	Turns on when the system battery runs low (warning level).	
17A			307	Absolute encoder battery error	Turns on when the battery for the absolute encoder runs low (warning level).	
17B			0V input	Connect 0V.		

Wiring Diagram

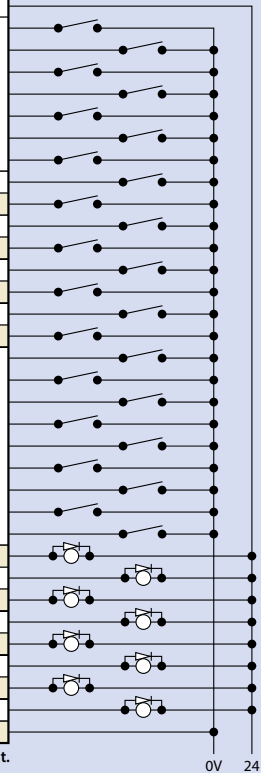

Note: This is for NPN. PNP will be different.

Positioner, 2-axis Independent Mode

Pin Number	Category	Port No.	Positioner Independent Mode	Functions		
1A	Input	P24	24V input	Connect 24V.		
1B			016	Position input 7	Specifies the position numbers to move to, using ports 010 to 022. The position numbers on the 1st and 2nd axes are assigned by parameter settings. The number can be specified either as BCD or binary.	
2A			017	Position input 8		
2B			018	Position input 9		
3A			019	Position input 10		
3B			020	Position input 11		
4A			021	Position input 12		
4B			022	Position input 13		
5A			023	Error reset		Resets minor errors. (Severe errors require a restart.)
5B			000	Start 1		Starts the movement to the selected position number on the 1st axis.
6A			001	Home Return 1		Performs Home Return on the 1st axis.
6B			002	Servo ON 1	Switches between servo ON and OFF for the 1st axis.	
7A			003	Pause 1	Pauses the motion on 1st axis when turned OFF, and resumes when turned ON.	
7B			004	Cancel 1	Cancels the movement on the 1st axis.	
8A			005	Start 2	Starts the movement to the selected position number on the 2nd axis.	
8B			006	Home Return 2	Performs Home Return on the 2nd axis.	
9A			007	Servo ON 2	Switches between servo ON and OFF for the 2nd axis.	
9B	008	Pause 2	Pauses the motion on 2nd axis when turned OFF, and resumes when turned ON.			
10A	009	Cancel 2	Cancels the movement on the 2nd axis.			
10B	010	Position input 1	Specifies the position numbers to move to, using ports 010 to 022. The position numbers on the 1st and 2nd axes are assigned by parameter settings. The number can be specified either as BCD or binary.			
11A	011	Position input 2				
11B	012	Position input 3				
12A	013	Position input 4				
12B	014	Position input 5				
13A	015	Position input 6				
13B	Output	N	300	Alarm	Turns off when an alarm occurs. (Contact B)	
14A			301	Ready	Turns on when the controller starts up normally and is in an operable state.	
14B			302	Positioning complete 1	Turns on when the movement to the specified position on the 1st axis is complete.	
15A			303	Home Return complete 1	Turns on when home return on the 1st axis is complete.	
15B			304	Servo ON output 1	Turns on when the 1st axis is in a servo ON state.	
16A			305	Positioning complete 2	Turns on when the movement to the specified position on the 2nd axis is complete.	
16B	306	Home Return complete 2	Turns on when home return on the 2nd axis is complete.			
17A	307	Servo ON output 2	Turns on when the 2nd axis is in a servo ON state.			
17B			0V input	Connect 0V.		

Wiring Diagram

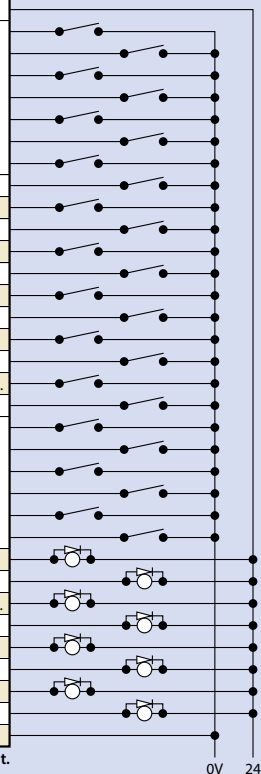

Note: This is for NPN. PNP will be different.

Explanation of I/O Signal Functions

Positioner, Teaching Mode

Pin Number	Category	Port No.	Positioner Teaching Mode	Functions		
1A	P24	016	24V input	Connect 24V.		
1B			JOG- on 1st axis	While the signal is input, the 1st axis is moved in the - (negative) direction.		
2A			JOG+ on 2nd axis	While the signal is input, the 2nd axis is moved in the + (positive) direction.		
2B			JOG- on 2nd axis	While the signal is input, the 2nd axis is moved in the - (negative) direction.		
3A			Specify inching (0.01mm)	Specifies how much to move during inching. (Total of the values specified for ports 019 to 022)		
3B			Specify inching (0.1mm)			
4A			Specify inching (0.5mm)			
4B			Specify inching (1mm)			
5A			Input	023	Error reset	Resets minor errors. (Severe errors require a restart.)
5B				000	Start	Starts moving to selected position.
6A				001	Servo ON	Switches between Servo ON and OFF.
6B				002	Pause	Pauses the motion when turned OFF, and resumes motion when turned ON.
7A				003	Position input 1	Ports 003 to 013 are used to specify the position number to move, and the position number for inputting the current position. When the teaching mode setting on port 014 is in the ON state, the current value is written to the specified position number.
7B				004	Position input 2	
8A	005	Position input 3				
8B	006	Position input 4				
9A	007	Position input 5				
9B	008	Position input 6				
10A	009	Position input 7				
10B	010	Position input 8				
11A	011	Position input 9				
11B	012	Position input 10				
12A	013	Position input 11				
12B	014	Teaching mode setting				
13A	015	JOG+ on 1st axis		While the signal is input, the 1st axis is moved in the plus direction.		
13B	300	Alarm	Turns off when an alarm occurs. (Contact B)			
14A	Output	301	Ready	Turns on when the controller starts up normally and is in an operable state.		
14B		302	Positioning complete	Turns on when the movement to the destination is complete.		
15A		303	Home Return complete	Turns on when the home return operation is complete.		
15B		304	Servo ON output	Turns on when servo is ON.		
16A		305	—	—		
16B		306	System battery error	Turns on when the system battery runs low (warning level).		
17A		307	Absolute encoder battery error	Turns on when the battery for the absolute encoder runs low (warning level).		
17B	N	0V input	Connect 0V.			

Wiring Diagram

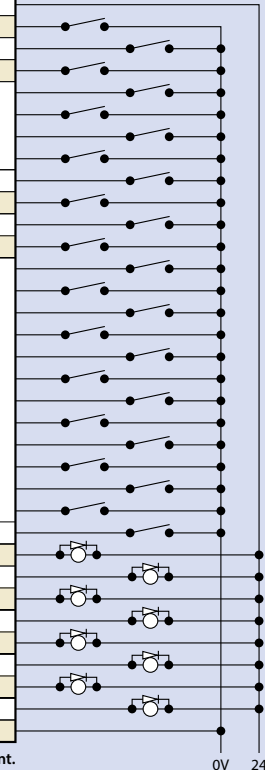

Note: This is for NPN. PNP will be different.

Positioner, DS-S-C1 Compatible Mode

Pin Number	Category	Port No.	Positioner DS-S-C1 Compatible Mode	Functions		
1A	P24	016	24V input	Connect 24V.		
1B			Position No. 1000	(Same as ports 004 through 015)		
2A			017	Position No. 2000	—	
2B			018	Position No. 4000	—	
3A			019	Position No. 8000	—	
3B			020	Position No. 10000	—	
4A			021	Position No. 20000	—	
4B			022	NC (*1)	—	
5A			Input	023	CPU reset	Resets the system to the same state as when the power is turned on.
5B				000	Start	Starts moving to selected position.
6A				001	Hold (Pause)	Pauses the motion when turned ON, and resumes motion when turned OFF.
6B				002	Cancel	Stops the motion when turned ON. The remaining motion is canceled.
7A				003	Interpolation setting	When this signal is turned ON for a 2-axis model, the actuator moves by linear interpolation.
7B				004	Position No. 1	Ports 004 through 016 are used to specify the position number to move. The numbers are specified as BCD.
8A	005	Position No. 2				
8B	006	Position No. 4				
9A	007	Position No. 8				
9B	008	Position No. 10				
10A	009	Position No. 20				
10B	010	Position No. 40				
11A	011	Position No. 80				
11B	012	Position No. 100				
12A	013	Position No. 200				
12B	014	Position No. 400				
13A	015	Position No. 800				
13B	Output	300	Alarm	Turns off when an alarm occurs. (Contact A)		
14A		301	Ready	Turns on when the controller starts up normally and is in an operable state.		
14B		302	Positioning complete	Turns on when the movement to the destination is complete.		
15A		303	—	—		
15B		304	—	—		
16A		305	—	—		
16B		306	System battery error	Turns on when the system battery runs low (warning level).		
17A	307	Absolute encoder battery error	Turns on when the battery for the absolute encoder runs low (warning level).			
17B	N	0V input	Connect 0V.			

Wiring Diagram

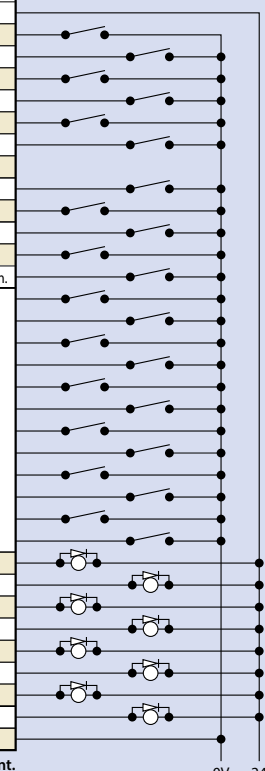

(*1) The input needs to be set to OFF. Be sure to leave this disconnected.

Note: This is for NPN. PNP will be different.

- Controller
- PMEC
AMEC
- PSEP
ASEP
DSEP
- MSEP
- ERC3
- ERC2
- PCON
-CA
- PCON
- ACON
- SCON
-CA
- MSCON
- PSEL
- ASEL
- SSEL**
- XSEL
- PS-24
- Pulse Motor
- Servo Motor (24V)
- Servo Motor (200V)
- Linear Servo Motor

Table of Specifications

	Item	Specifications
Basic Specifications	Connected actuator	RCS2 series actuator / single axis robot / linear servo actuator
	Input Voltage	Single-phase AC90V to AC126.5V Single-phase AC180V to AC253V
	Power Supply Capacity	Max. 1660VA (for 400W, 2-axis operation)
	Dielectric strength voltage	DC500V 10MΩ or higher
	Withstand voltage	AC500V 1 min.
	Rush current	Control Power 15A / Motor Power 37.5A Control Power 30A / Motor Power 75A
	Vibration resistance	XYZ directions 10 to 57Hz, One side amplitude: 0.035mm (continuous), 0.075mm (intermittent) 58 to 150 Hz 4.9 m/s ² (continuous), 9.8 m/s ² (intermittent)
Control specification	Number of control axes	1 axis / 2 axes
	Maximum total output of connected axis	400W 800W
	Position detection method	Incremental encoder / Absolute encoder
	Speed setting	1mm/sec and up, the maximum depends on actuator specifications
	Acceleration setting	0.01G and up, the maximum depends on the actuator
	Operating method	Program operation / Positioner operation (switchable)
Program	Programming language	Super SEL language
	Number of programs	128 programs
	Number of program steps	9,999 steps
	Number of multi-tasking programs	8 programs
	Positioning Points	20,000 points
	Data memory device	FLASHROM (A system-memory backup battery can be added as an option)
Communication	Data input method	Teaching pendant or PC software
	Number of I/O	24 input points / 8 output points (NPN or PNP selectable)
	I/O power	Externally supplied 24VDC ± 10%
	PIO cable	CB-DS-PIO□□□ (supplied with the controller)
	Serial communications function	RS232C (D-Sub Half-pitch connector) / USB connector
	Field Network	DeviceNet, CC-Link, ProfiBus
	Motor Cable	CB-ACS-MA□□□ (Max. 20m)
General specifications	Encoder cable	CB-RCP2-PA□□□ (Max. 20m)
	Protection function	Motor overcurrent, Motor driver temperature check, Overload check, Encoder open-circuit check Soft limit over, system error, battery error, etc.
	Ambient operating humidity and temperature	0 to 40°C 10 to 95% (non-condensing)
	Ambient atmosphere	Free from corrosive gases. In particular, there shall be no significant dust.
	Protection class	IP20
	Weight	1.4kg
External dimensions	100mm (W) x 202.6mm (H) x 126mm (D)	

External Dimensions

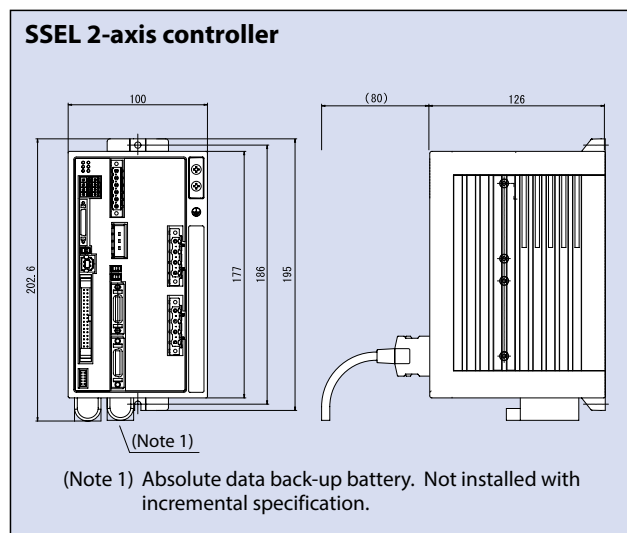
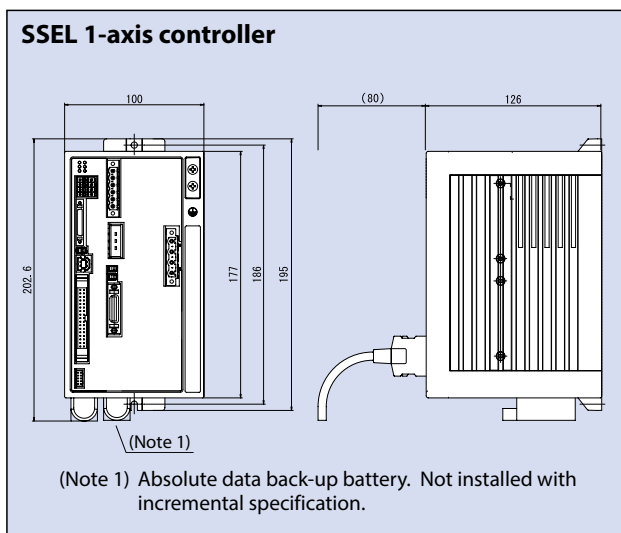

Name of Each Part

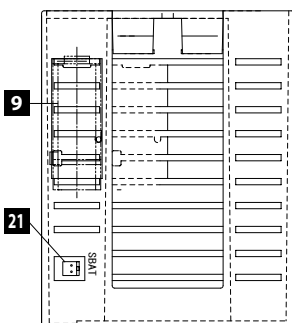
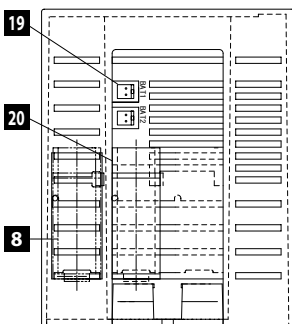
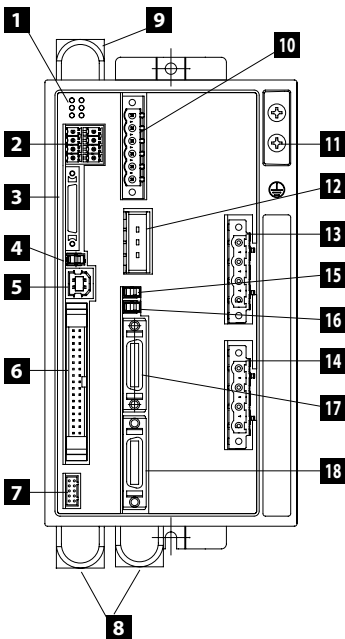

1 Status indicator LEDs

These LEDs are used to indicate the operating condition of the controller.

The LED status indicators are as follows:

- PWR : Power is input to controller.
- RDY : The controller is ready to perform program operation.
- ALM : The controller is abnormal.
- EMG : An emergency stop is actuated and the drive source is cut off.
- SV1 : The axis 1 actuator servo is on.
- SV2 : The axis 2 actuator servo is on.

2 System I/O connector

Connector for emergency stop / enable input / brake power input, etc.

3 Teaching pendant connector

A half-pitch I/O 26-pin connector that connects a teaching pendant when the running mode is MANU. A special conversion cable is needed to connect a conventional Dsub, 25-pin connector.

4 Mode switch

This switch is used to specify the running mode of the controller. The left position indicates the MANU (manual operation) mode, while the right position indicates the AUTO (automatic operation) mode. Teaching can only be performed as manual operation, and automatic operation using external I/Os is not possible in the MANU mode.

5 USB connector

A connector for PC connection via USB. If the USB connector is connected, the TP connector is disabled and all communication inputs to the TP connector are cut off.

6 I/O Connector

A connector for interface I/Os.

34-pin flat cable connector for DIO (24IN/8OUT) interface.

I/O power is also supplied to the controller via this connector (Pin No. 1 and No. 34).

7 Panel unit connector

A connector for the panel unit (optional) that displays the controller status and error numbers.

8 Absolute data backup battery

When an absolute-type axis is operated, this battery retains position data even after the power is cut off.

9 System memory backup battery (Option)

This battery is needed if you wish to retain various data recorded in the SRAM of the controller even after the power is cut off. This battery is optional. Specify it if necessary.

10 Power supply connector

AC power connector. Divided into the control power input and motor power input.

11 Grounding screw

Protective grounding screw. Always ground this screw.

12 External regenerative resistor connector

A connector for the regenerative resistor that must be connected when the built-in regenerative resistor alone does not offer sufficient capacity in high-acceleration/ high-load operation, etc.

Whether or not an external regenerative resistor is necessary depends on the conditions of your specific application such as the axis configuration.

13 Motor connector for axis 1

Connects the motor cable of the axis 1 actuator.

14 Motor connector for axis 2

Connects the motor cable of the axis 2 actuator.

15 Brake switch for axis 1

This switch is used to release the axis brake. Setting it to the left position (RLS side) forcibly releases the brake, while setting it to the right position (NOM side) causes the controller to automatically control the brake.

16 Brake switch for axis 2

This switch is used to release the axis brake. Setting it to the left position (RLS side) forcibly releases the brake, while setting it to the right position (NOM side) causes the controller to automatically control the brake.

17 Encoder connector for axis 1

Connect the encoder cable of the axis 1 actuator.

18 Encoder connector for axis 2

Connect the encoder cable of the axis 2 actuator.

19 Absolute-data backup battery connector for axis 1

A connector for the battery that backs up absolute data for axis 1 when the actuator uses an absolute encoder.

20 Absolute-data backup battery connector for axis 2

A connector for the battery that backs up absolute data for axis 2 when the actuator uses an absolute encoder.

21 System-memory backup battery connector

A connector for the system-memory backup battery.

PMEC
AMEC

PSEP
ASEP
DSEP

MSEP

ERC3

ERC2

PCON
-CA

PCON

ACON

SCON
-CA

MSCON

PSEL

ASEL

SSEL

XSEL

PS-24

Pulse
Motor

Servo
Motor
(24V)

Servo
Motor
(200V)

Linear
Servo
Motor

SSEL Controller

Options

Teaching Pendant

■ **Features** A teaching device for entering programs and positions, test runs, and monitoring.

■ **Model/Price**

Model	Description
SEL-T-J	Standard type with adapter cable
SEL-TD-J	Deadman's switch type and adapter cable

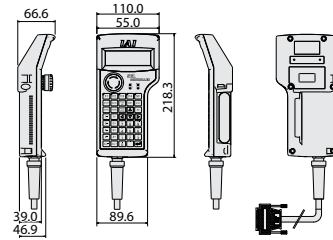
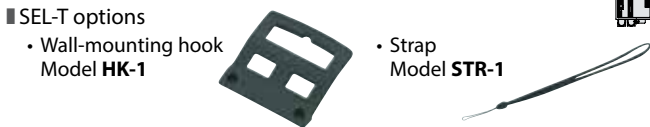
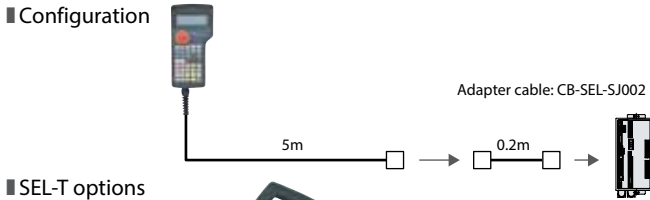

■ **Specifications**

Item	SEL-T-J	SEL-TD-J
3-position Enable Switch	No	Yes
ANSI/UL standards	Non-compliant	Compliant
CE mark	Compliant	
Display	20 char. x 4 lines	
Ambient Operating Temp./Humidity	0~40°C 10~90% RH (non-condensing)	
Protective structure	IP54	
Weight	Approx. 0.4kg (not incl. cable)	

PC software (Windows Only)

■ **Features** A startup support software for entering programs/positions, performing test runs, and monitoring. More functions have been added for debugging, and improvements have been made to shorten the start-up time.

■ **Model** **IA-101-X-MW-JS** (with RS232C cable + adapter cable)
IA-101-X-MW (with RS232C cable)

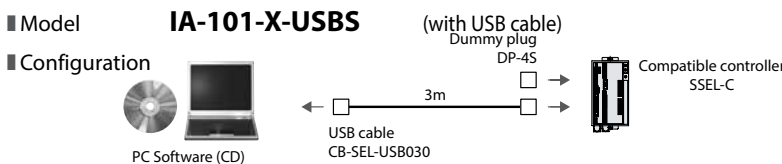
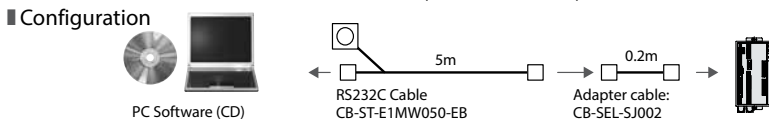

Supported Windows OS:
2000 SP4 or later / XP SP2 or later / Vista / 7

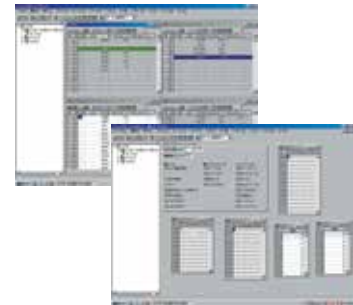

Note
Only versions 6.0.0.0 and later can be used with the SSEL controller.

Regenerative Resistor Unit

■ **Features** This unit converts regenerative current that generates when the motor decelerates, to heat. Check the total wattage of the actuators to be operated and provide a regenerative resistance unit or units if required.

■ **Model** **RESU-2** (Standard specification)
RESUD-2 (DIN rail mount specification)
RESU-1 (Standard specification, second or subsequent unit)
RESUD-1 (DIN rail mount specification, second or subsequent unit)

* If two regenerative units are required, arrange one RESU-2/RESUD-2 (1st) and one RESU-1/RESUD-1 (2nd or after).

■ **Required Number of Units**

Model	Horizontal	Vertical
0 units	~200W	~200W
1 unit	~800W	~600W
2 units		~800W

* Depending on the operating conditions, more regenerative resistors may be needed.

* Please see MCON section page 662 for specification information and drawings.

Panel Unit

■ **Features** Display device that shows the error code from the controller or the currently running program number.

■ **Model** **PU-1** (Cable length: 3m)

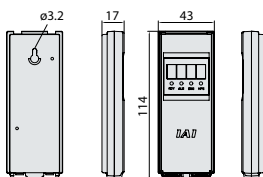

Absolute Data Backup Battery

■ **Features** Battery for saving absolute data, when operating an actuator with an absolute encoder. Same as the battery used for system memory backup.

■ **Model** **AB-5**



System Memory Backup Battery

■ **Features** This battery is required, for example, when you are using global flags in the program and you want to retain your data even after the power has been turned OFF.

■ **Model** **AB-5-CS** (with case)
AB-5 (Standalone battery)



693 SSEL

Options

Dummy Plug

Features When connecting the SSEL controller to a computer with a USB cable, this plug is inserted in the teaching port to shut off the enable circuit. (Supplied with the PC software IA-101-X-USB)

Model **DP-4S**



USB Cable

Features A cable for connecting the controller to the USB port to a computer. A controller with no USB port (e.g. XSEL) can be connected to the USB port of a computer by connecting an RS232C cable to the USB cable via a USB adapter. (See PC software IA-101-X-USBMW)

Model **CB-SEL-USB030** (Cable length: 3m)



Adapter Cable

Features An adapter cable to connect the D-sub 25-pin connector from the teaching pendant or a PC to the teaching connector (half-pitch) of the SSEL controller.

Model **CB-SEL-SJ002** (Cable length: 0.2m)



Spare parts

When you need spare parts after purchasing the product, such as when replacing a cable, refer to the list of models below.

Motor cable/Motor robot cable

Model **CB-RCC-MA□□□□ / CB-RCC-MA□□□□-RB**

* Enter the cable length (L) into □□□□. Compatible to a maximum of 30 meters. Ex.: 080 = 8m

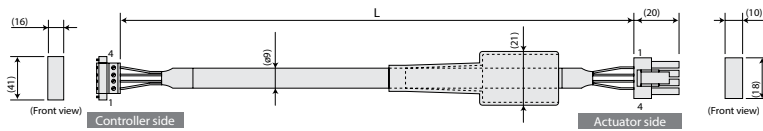

Min. bend radius $r = 50\text{mm}$ or larger (when movable type is used)
* Only the robot cable is to be used in a cable track.

Wire	Color	Signal	No.	Signal	Color	Wire
0.75sq	Green	PE	1	1	U	Red
	Red	U	2	2	V	White
	White	V	3	3	W	Black
	Black	W	4	4	PE	Green

Encoder cable/Encoder robot cable

Model **CB-RCS2-PA□□□□ / CB-X3-PA□□□□**

* Enter the cable length (L) into □□□□. Compatible to a maximum of 30 meters. Ex.: 080 = 8m

Min. bend radius $r = 50\text{mm}$ or larger (when movable type is used)
* Only the robot cable is to be used in a cable track.

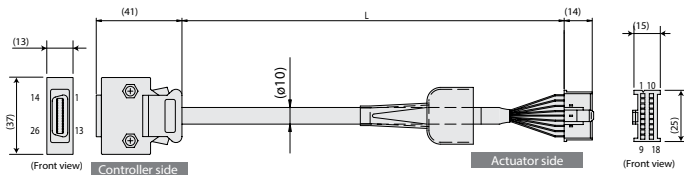

Wire	Color	Signal	No.	No.	Signal	Color	Wire
---	---	---	10	1	A	White	White
---	---	---	11	2	B	Black	Black
---	---	---	12	3	A+	White	White
---	---	---	13	4	B+	Black	Black
---	---	---	14	5	A-	White	White
---	---	---	15	6	B-	Black	Black
---	---	---	16	7	OP	Orange	Brown/White
---	---	---	17	8	OP	Orange	Brown/Black
---	---	---	18	9	FG	Green	Green
---	---	---	19	10	SP	Blue	Blue
---	---	---	20	11	BN	Orange	Orange
---	---	---	21	12	BAL+	Black	Black
---	---	---	22	13	BAL-	Yellow	Yellow
---	---	---	23	14	VCC	Green	Green
---	---	---	24	15	GND	Brown	Brown
---	---	---	25	16	GND	Gray	Gray
---	---	---	26	17	BK-	Black	Black
---	---	---	27	18	BK+	Gray	Red

Encoder cable/Encoder robot cable for RCS2-RT6/RT6R/RT7R/RA13R

Model **CB-RCS2-PLA□□□□ / CB-X2-PLA□□□□**

* Enter the cable length (L) into □□□□. Compatible to a maximum of 30 meters. Ex.: 080 = 8m

Min. bend radius $r = 50\text{mm}$ or larger (when movable type is used)
* Only the robot cable is to be used in a cable track.

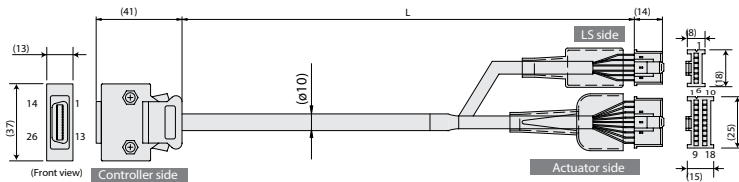

Wire	Color	Signal	No.	No.	Signal	Color	Wire
---	---	---	10	1	A	White/Orange	White/Orange
---	---	---	11	2	OV	White/Green	White/Green
---	---	---	12	3	LS	Brown/Blue	Brown/Blue
---	---	---	13	4	CREEP	Brown/Yellow	Brown/Yellow
---	---	---	14	5	OP	Brown/Black	Brown/Black
---	---	---	15	6	OV	Brown/Black	Brown/Black
---	---	---	16	7	---	---	---
---	---	---	17	8	---	---	---
---	---	---	18	9	FG	Green	Green
---	---	---	19	10	SP	Blue	Blue
---	---	---	20	11	BN	Orange	Orange
---	---	---	21	12	BAL+	Black	Black
---	---	---	22	13	BAL-	Yellow	Yellow
---	---	---	23	14	VCC	Green	Green
---	---	---	24	15	GND	Brown	Brown
---	---	---	25	16	GND	Gray	Gray
---	---	---	26	17	BK-	Black	Black
---	---	---	27	18	BK+	Blue	Yellow

I/O Flat Cable

Model **CB-DS-PIO□□□□**

* Enter the cable length (L) into □□□□. Compatible to a maximum of 10 meters. Ex.: 080 = 8m

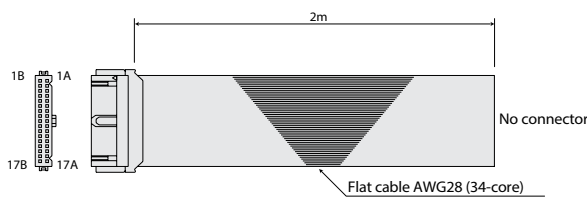

Pin No.	Color	Wire	Pin No.	Color	Wire
1A	Brown 1		9B	Gray 2	
1B	Red 1		10A	White 2	
2A	Orange 1		10B	Black 2	
2B	Yellow 1		11A	Brown-3	
3A	Green 1		11B	Red 3	
3B	Blue 1		12A	Orange 3	
4A	Purple 1		12B	Yellow 3	
4B	Gray 1		13A	Green 3	
5A	White 1		13B	Blue 3	
5B	Black 1		14A	Purple 3	
6A	Brown-2		14B	Gray 3	
6B	Red 2		15A	White 3	
7A	Orange 2		15B	Black 3	
7B	Yellow 2		16A	Brown-4	
8A	Green 2		16B	Red 4	
8B	Blue 2		17A	Orange 4	
9A	Purple 2		17B	Yellow 4	

- Controller
- PMEC
AMEC
- PSEP
ASEP
DSEP
- MSEP
- ERC3
- ERC2
- PCON
-CA
- PCON
- ACON
- SCON
-CA
- MSCON
- PSEL
- ASEL
- SSEL
- XSEL**
- PS-24
- Pulse Motor
- Servo Motor (24V)
- Servo Motor (200V)
- Linear Servo Motor



Program controller
For RCS3 / RCS2 series

List of Models

Multi-axis program controller for operating RCS2 Series actuators. Up to 8 axes can be simultaneously controlled.

Type	J	K	P	Q	R	S
Name	Compact Type	General Purpose Type	Large-Capacity Type	Large-Capacity Type (Global specification)	High-function Type	High-function Type (Global specification)
External View						
Description	Compact, low-cost type ideal for operating low-output actuators	Standard type offering excellent expandability	Large-capacity type capable of controlling up to six axes or 2,400W	Large-capacity type conforming to safety category 4	Up to eight axes can be operated, high-function type comes with many options	High-function type confirmed to safety-category 4
Maximum number of control axes	4-axis		6-axis		8-axis	
Number of positions	3,000 positions		20,000 positions		Max. 53,332 positions (The number varies according to the number of controlled axes.)	
Total Number of Connectable W	800W (*1)	1600W	2400W		2400W	
Power Supply	Single-phase AC100V/Single-phase AC200V		Single-phase AC200V/3-phase AC200V		Single-phase AC200V/3-phase AC200V	
Safety Category	B		B	Category 4 compatible	B	Category 4 compatible
Safety Rating	—		CE	CE	(*2)	(*2)
Standard Price	—					

(*1) The maximum output for 1 shaft during vertical operation is limited to 600W.
(*2) Preparing for CE compliance

Model

[XSEL-J/K type]

(Note) To specify multiple options, enter them in alphabetical order. (Example: Brake + Home sensor → BL)

*Notation for 2 - 4 axes depends on the number of axes to be used.

XSEL - [] - [] - [] - [] - [] - [] - [] - [] - [] - [] - [] - [] - []

Series	Type	Number of Axes	Motor	(Specs for 1st axis)		(Specs for axis 2 - 4)			(Slot 1)	(Slot 2)	(Slot 3)	(Slot 4)	I/O Cable Length	Power/Voltage
				Encoder	Option	Motor	Encoder	Option	Standard I/O	Expansion I/O				
J	Small type			B		I	I		N1	N3	P1	P3	1	Single-phase AC100V
K	General type			C		A	A						2	Single-phase AC200V
KE	CE-compatible type			HA									0	No cable
KT	Safety-compliant type	1	Single-axis model	L									2	2m (standard)
KET	CE, Safety-compliant type	2	2-axis model	M									3	3m
		3	3-axis model	S									5	5m
		4	4-axis model	I										
				A										
20	20W servo motor	200	200W servo motor	20	20W servo motor	200	200W servo motor		E		P1			
30D	30W servo motor for RCS2	300	300W servo motor	30D	30W servo motor for RCS2	300	300W servo motor		N1		P2			
30R	30W servo motor for RS	400	400W servo motor	30R	30W servo motor for RS	400	400W servo motor		N2		P3			
60	60W servo motor	600	600W servo motor	60	60W servo motor	600	600W servo motor		N3		SA			
100	100W servo motor	750	750W servo motor	100	100W servo motor	750	750W servo motor				SB			
150	150W servo motor			150	150W servo motor						SC			

* E (Not used) is for expansion I/O only.

* For type J, 1-axis and 2-axis models cannot be expanded. On 3-axis and 4-axis models, only expansion slot 2 can be used.

* The expansion SIO board is only for type K. (Cannot be used for type J.)

* For N3/P3, standard I/O is dedicated to type J, expansion I/O is dedicated to type K.

[XSEL-P/Q type]

(Note) To specify multiple options, enter them in alphabetical order. (Example: Brake + Home sensor → BL)

*Notation for 2 - 6 axes depends on the number of axes to be used.

XSEL - [] - [] - [] - [] - [] - [] - [] - [] - [] - [] - [] - [] - []

Series	Type	Number of Axes	Motor	(Specs for 1st axis)		(Specs for axis 2 - 6)			Dedicated network slot	(Slot 1)	(Slot 2)	(Slot 3)	(Slot 4)	I/O Cable Length	Power/Voltage
				Encoder	Option	Motor	Encoder	Option		Standard I/O	Expansion I/O				
P	High-capacity type			B		I	I		Blank					2	Single-phase AC200V
Q	Safety-compliant, high capacity type			C		A	A		DV					3	Three-phase AC200V
				HA					CC					2L	Dedicated linear single-phase AC200V
		1	Single-axis model	L					PR					3L	Dedicated linear 3-phase AC200V
		2	2-axis model	M					EP						
		3	3-axis model	S					ET						
		4	4-axis model	I											
		5	5-axis model	A											
		6	6-axis model												
12	12W servo motor	200	200W servo motor	12	12W servo motor	200	200W servo motor		E					0	No cable
20	20W servo motor	200S	For LSA-S10/N15	20	20W servo motor	200S	For LSA-S10/N15		N1					2	2m (standard)
30D	30W servo motor for RCS2	300	300W servo motor	30D	30W servo motor for RCS2	300	300W servo motor		N2					3	3m
30R	30W servo motor for RS	300S	For LSA-N19	30R	30W servo motor for RS	300S	For LSA-N19		N3					5	5m
60	60W servo motor	400	400W servo motor	60	60W servo motor	400	400W servo motor		P1						
100	100W servo motor	600	600W servo motor	100	100W servo motor	600	600W servo motor		P2						
100S	For LSA-N10	750	750W servo motor	100S	For LSA-N10	750	750W servo motor		P3						
150	150W servo motor	1000	1000W servo motor (linear only)	150	150W servo motor	1000	1000W servo motor (linear only)		MC						
									S						

* Enter 2L or 3L when operating a linear servo actuator. Otherwise, enter 2 or 3.

* With the standard I/O and the expansion I/O, if you do not select the input/output board (N□ / P□), input "0" (no cable) as the I/O cable length symbol.

* If expansion I/O will not be used, enter E (not used) for slots 2 to 4. If you are using expansion I/O, enter the expansion I/O code in the desired slot. If an expansion I/O is specified, the controller chassis will come with the expansion I/O base. (See P705-706) If you will not be using the expansion I/O initially but will be adding it later, specify the chassis with I/O expansion board, but specify 5 for slots 2 to 4.

*Maximum of 2 MC cards can be used for the expansion I/O slots.

e.g. Expansion I/O on slot 2, remaining slots unused XSEL-P-2-100A-100A-N1-N1EE-2-3
Expansion I/O base attached, but not the expansion I/O XSEL-P-2-100A-100A-N1-S5S-2-3

Note:

For axis 5 and 6 of XSEL-P/Q type, the following actuators are unavailable: LSA series, RCS2-RA7/SRA7/SRGS7/SRGD7 series, RCS2-□□5N (Mini ROBO) series, and NS-SXM□/SZM□ (incremental specification only for both).

- Controller
- PMEC
AMEC
- PSEP
ASEP
DSEP
- MSEP
- ERC3
- ERC2
- PCON
-CA
- PCON
- ACON
- SCON
-CA
- MCON
- PSEL
- ASEL
- SSEL
- XSEL
- PS-24
- Pulse Motor
- Servo Motor (24V)
- Servo Motor (200V)
- Linear Servo Motor

Model

[XSEL-R/S type]

(Note) To specify multiple options, enter them in alphabetical order. (Example: Brake + Home sensor → BL)

XSEL - [] - [] - [] [] [] [] - ([] [] []) - [] [] [] - [] [] - [] - []

series Type Number of connected axes Motor Encoder Option (Specs for axis 2-8) Motor Encoder Option Dedicated network slot (Slot 1) (Slot 2) (Slot 3) I/O slot (Slot 1) (Slot 2) I/O cable length Power/voltage

R	Standard specification
S	Global specification

1	Single-axis model
2	2-axis model
3	3-axis model
4	4-axis model
5	5-axis model
6	6-axis model
7	7-axis model
8	8-axis model

I	Incremental
A	Absolute
G	Quasi-absolute

B	Brake-equipped specification
C	Creep sensor specification
HA	High acceleration/deceleration specification
L	Home sensor/LS-compatible
M	Master axis spec
S	Slave axis spec

E	Not used
EP	EtherNet/IP
EC	EtherCAT

E	Not used
IA	IA net-compatible

0	No cable
2	2m (standard)
3	3m
5	5m

* With the I/O slots, if you do not select the input/output board (N□ / P□), input "0" (no cable) as the I/O cable length symbol.

12	12W	150	150W
20	20W	200	200W
30D	30W for DS	200S	200W for linear
30R	30W for RS	300	300W
60	60W	400	400W
100	100W	600	600W
100S	100 W for linear	750	750W

E	Not used	P1	Input 32/Output 16 (PNP)
N1	Input 32/Output 16 (NPN)	P2	Input 16/Output 32 (PNP)
N2	Input 16/Output 32 (NPN)	P3	Input 48/Output 48 (PNP)
N3	Input 48/Output 48 (NPN)	MC	Electronic cam Pulse I/O board
		DG	DeviceNet Gateway master board

(*) Slots 1 to 3 are dedicated network slots where the selectable boards are fixed. Select one of the specified boards and enter the corresponding code.
 (*) The above I/O boards can be installed in both I/O slots 1 and 2, but you can specify "DG" (DeviceNet Gateway board) only for slot 1.
 (*) The dedicated network slots and I/O slots can be used at the same time.

* Notes on selecting single-axis/Cartesian robots
 The total wattage of single-axis/Cartesian robots connectable to the XSEL-R/S type is 2400 W in the case of the three-phase specification and 1600 W in the case of the single-phase specification.
 The maximum wattage per axis is 750 W. Make sure the total wattage of each axis does not exceed the specified value.

Note: For XSEL-R/S type, the following actuators are unavailable:
 LSA series, RCS2-RA7/SRA7/SRGS7/SRGD7 series, RCS2-□□5N (Mini ROBO) series, and NS-SXM□/SZM□ (incremental specification only for both).

Model Description Examples by Controller Types

Below shows model description examples for each controller type.
 For more information about the I/O slots, please refer to the table "Possible I/O configuration by controller types" next page.

[XSEL-J/K type]

XSEL - J - 4 - 200A - 100A - 60A - 30A - N1 - N1EE - 2 - 1

Series Type Number of axes Connected actuator motor wattage, Encoder type Slot 1 Slot 2 I/O cable length Power voltage

I/O slot detail

[XSEL-P/Q type]

XSEL - P - 4 - 200A - 100A - 60A - 30A - CC - N1 - N1N1E - 2 - 3

Series Type Number of axes Connected actuator motor wattage, Encoder type Dedicated network slot 1 Slot 1 Slot 2/3/4 I/O cable length Power voltage

I/O slot detail

[XSEL-R/S type]

XSEL - R - 4 - 200A - 100A - 60A - 30A - EPDVE - N1E - 2 - 3

Series Type Number of axes Connected actuator motor wattage, Encoder type Dedicated network slot 1/2/3 Slot 1/2 I/O cable length Power voltage

I/O slot detail

697 XSEL

Possible I/O Configuration by Controller Types

Possible I/O (input and output) configuration varies depending on the XSEL controller type.

Please refer to the table below to find out possible I/O configuration for your desired controller type.

* For explanation of the symbols given to each slot in the table below, please refer to each controller model page, P696 and 697.

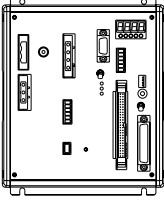
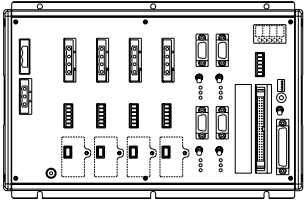
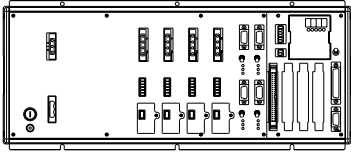
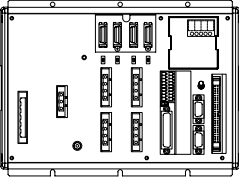
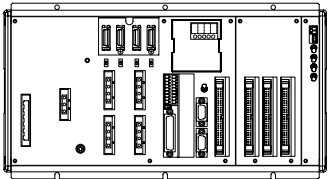
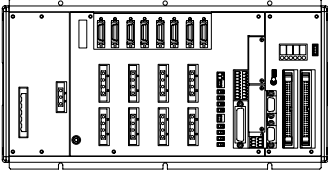
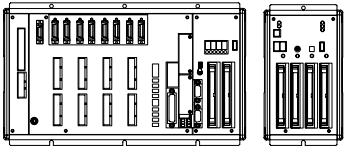
Controller type		External view	Possible I/O configuration by I/O slot									
			Dedicated network slot 1	Dedicated network slot 2	Dedicated network slot 3	Slot 1	Slot 2	Slot 3	Slot 4	Extension I/O unit		
J type	1-axis/2-axis specification		(n/a)	(n/a)	(n/a)		(n/a)	(n/a)	(n/a)	(n/a)		
	3-axis/4-axis specification		(n/a)	(n/a)	(n/a)	N1 N3 P1 P3 DV CC PR ET	E N1 N2 N3 P1 P2 P3 S□	(n/a)	(n/a)	(n/a)		
K type	Standard specification		(n/a)	(n/a)	(n/a)		E N1 N2 N3 P1 P2 P3 S□	E N1 N2 N3 P1 P2 P3 S□	E N1 N2 N3 P1 P2 P3 S□	(n/a)		
P type Q type	Standard specification		(n/a)	(n/a)	(n/a)		(n/a)	(n/a)	(n/a)	(n/a)		
	With extension slot specification		(n/a) DV CC PR EP ET	(n/a)	(n/a)	E N1 N2 N3 P1 P2 P3	E N1 N2 N3 P1 P2 P3 S	E N1 N2 N3 P1 P2 P3 S	E N1 N2 N3 P1 P2 P3 S	(n/a)		
R type S type	Standard specification		E EP EC	E DV CC PR	E IA	E N1 N2 N3 P1 P2 P3 MC DG	E N1 N2 N3 P1 P2 P3 MC	(n/a)	(n/a)	(n/a)		
	With extension I/O unit							(n/a)	(n/a)	E N1 N2 N3 P1 P2 P3	E N1 N2 N3 P1 P2 P3	E N1 N2 N3 P1 P2 P3

- Controller
- PMEC
AMEC
- PSEP
ASEP
DSEP
- MSEP
- ERC3
- ERC2
- PCON
-CA
- PCON
- ACON
- SCON
-CA
- MSCON
- PSEL
- ASEL
- SSEL
- XSEL
- PS-24
- Pulse Motor
- Servo Motor (24V)
- Servo Motor (200V)
- Linear Servo Motor

System Configuration

■ XSEL-J (Compact) / K (General) / KE (CE type)

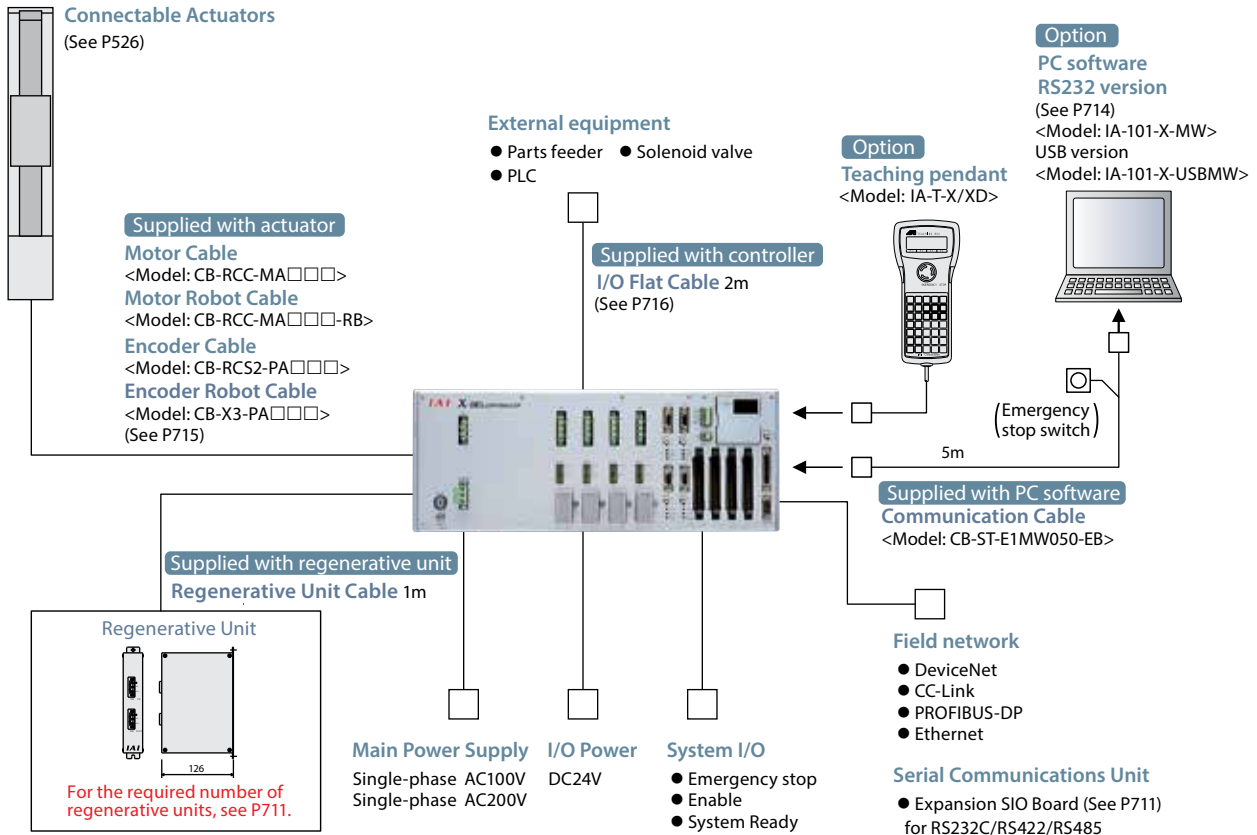

■ XSEL-P (Large-capacity type) / Q (Large-capacity global specification)

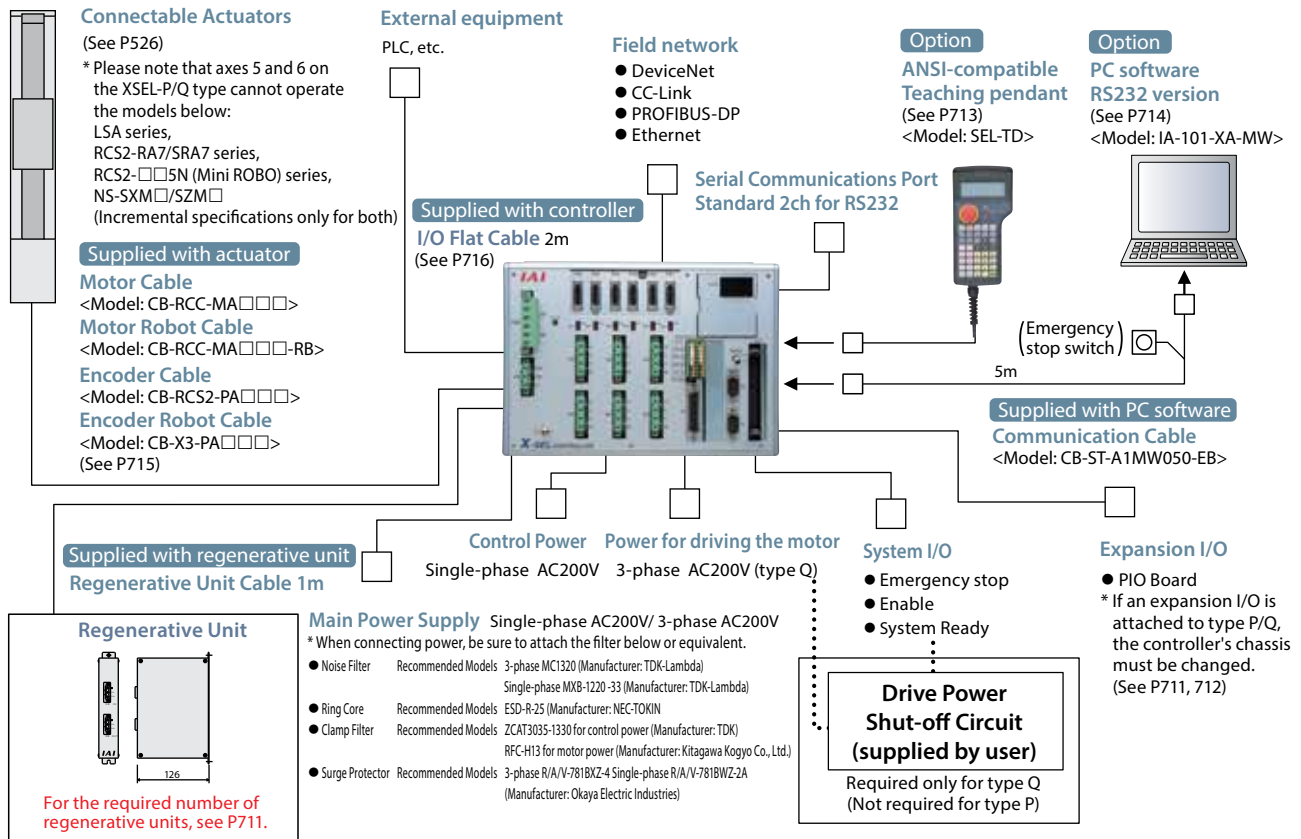

System Configuration

XSEL-R type
(High-functionality specification)

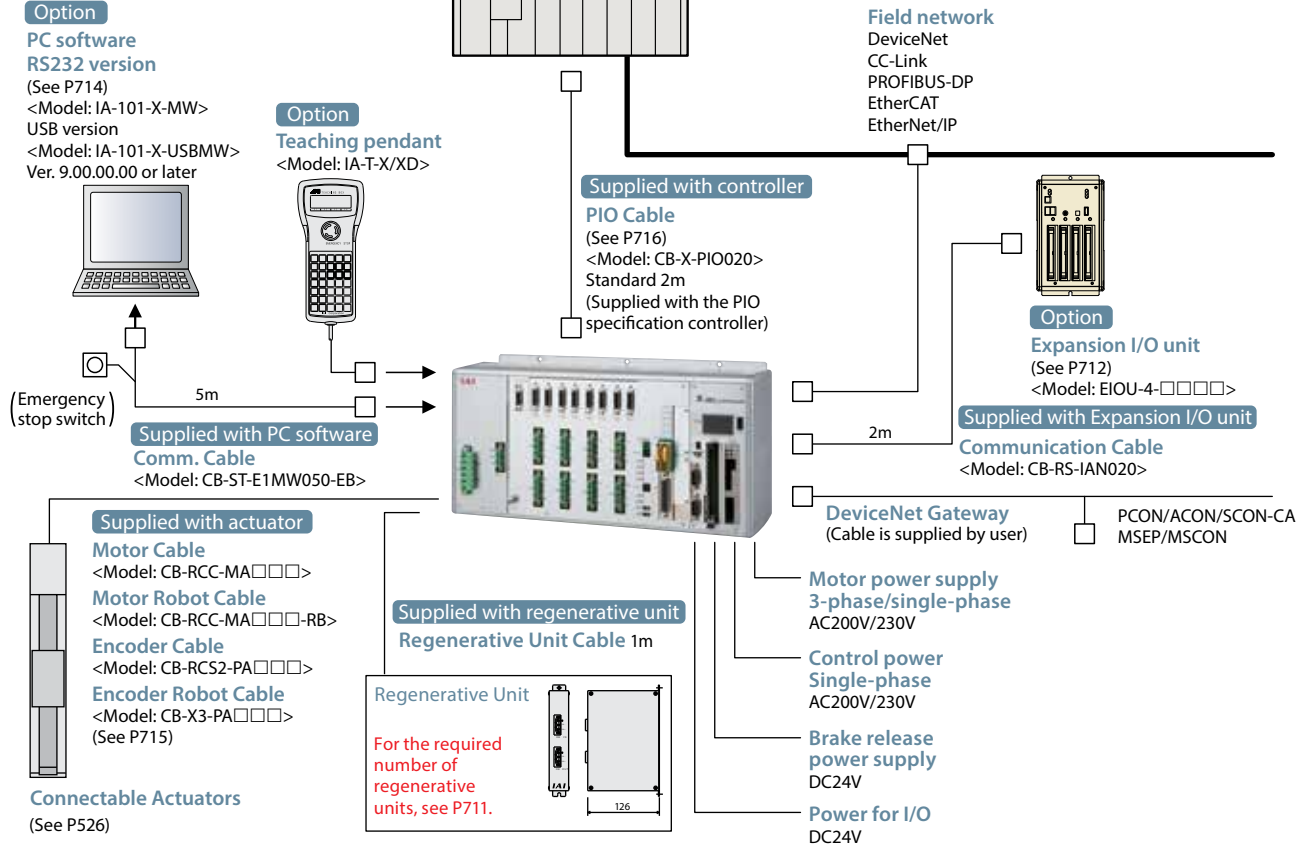

XSEL-S type
(High-functionality global specification)

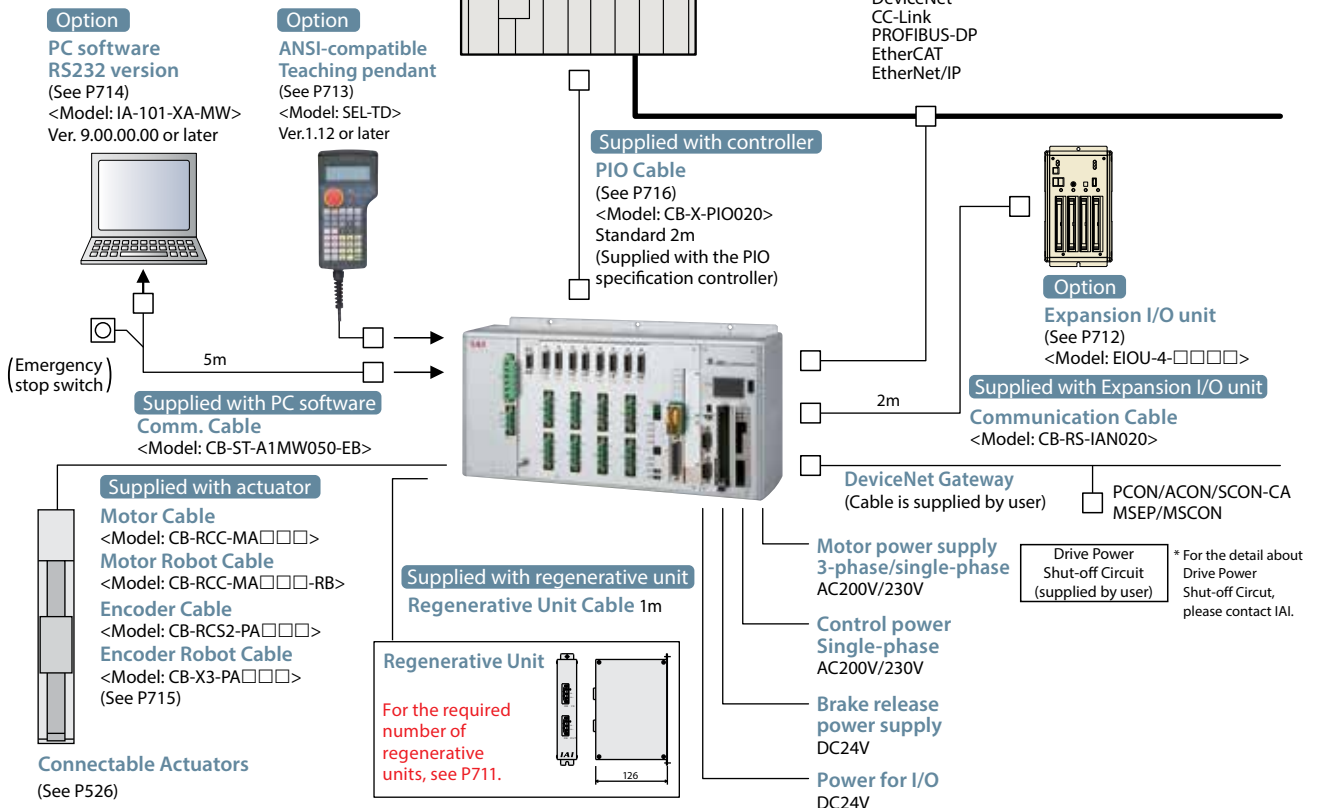

PMEC
AMEC

PSEP
ASEP
DSEP

MSEP

ERC3

ERC2

PCON
-CA

PCON

ACON

SCON
-CA

MSCON

PSEL

ASEL

SSEL

XSEL

PS-24

Pulse Motor

Servo Motor (24V)

Servo Motor (200V)

Linear Servo Motor

I/O wiring drawing

Input section External input specification (NPN specification)

Item	Specifications
Input voltage	DC24V ±10%
Input current	7mA / circuit
ON/OFF voltage	ON Voltage... Min DC16.0V / OFF Voltage... Max DC5.0V
Isolation method	Photocoupler
Externally Connected Equipment	① Non-Voltage Contact (Minimum load around DC5V, 1mA) ② Photoelectric Proximity Sensor (NPN Type) ③ PLC Transistor Output (Open Collector Type) ④ PLC Contact Output (Minimum Load approx. DC5V, 1mA)

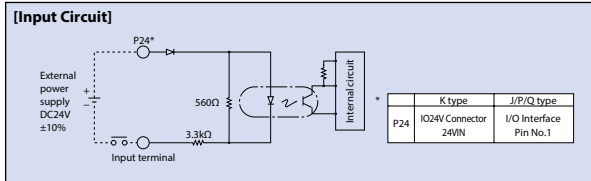

Input section External input specification (PNP specification)

Item	Specifications
Input voltage	DC24V ±10%
Input current	7mA / circuit
ON/OFF voltage	ON Voltage... Min DC8V / OFF Voltage... Max DC19V
Isolation method	Photocoupler
Externally Connected Equipment	(1) Non-Voltage Contact (Minimum load around DC5V, 1mA) (2) Photoelectric Proximity Sensor (PNP Type) (3) PLC Transistor Output (Open Collector Type) (4) PLC Contact Output (Minimum Load approx. DC5V, 1mA)

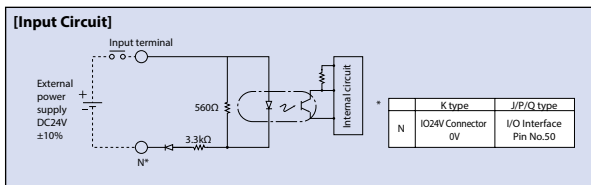

Output section External output specification (NPN specification)

Item	Specifications
Load Voltage	DC24V
Max. load current	100mA / point 400 mA
Leak current	Peak (Total Current)
Isolation method	Max 0.1mA / point
Externally Connected Equipment	Photocoupler
Equipment	① Miniature Relay, ② PLC Input Unit

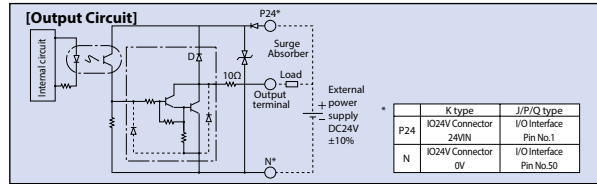

Output section External input specification (PNP specification)

Item	Specifications
Load Voltage	DC24V
Max. load current	100mA / 1 point 400mA / 8 ports (Note)
Leak current	Max 0.1mA / point
Isolation method	Photocoupler
Externally Connected Equipment	(1) Miniature Relay, (2) PLC Input Unit

(Note) 400mA is the maximum total load current for each set of the eight ports from output port No. 300. (The maximum total current output for output port No. 300+n to No. 300+n+7 must be 400mA, where n = 0 or a multiple of eight.)

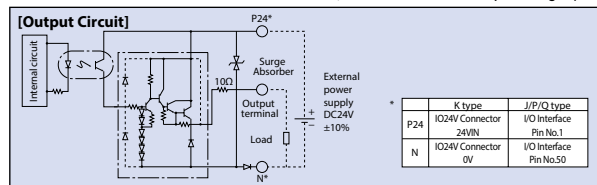

I/O Signal table

Standard I/O Signal Table (when N1 or P1 is selected)

Pin No.	Classification	Port No.	Standard Settings
1		—	(J/P/Q type: 24V connection / K type: NC)
2		000	Program start
3		001	General Purpose Input
4		002	General Purpose Input
5		003	General Purpose Input
6		004	General Purpose Input
7		005	General Purpose Input
8		006	General Purpose Input
9		007	Program Specification (PRG No. 1)
10		008	Program Specification (PRG No. 2)
11		009	Program Specification (PRG No. 4)
12		010	Program Specification (PRG No. 8)
13		011	Program Specification (PRG No. 10)
14		012	Program Specification (PRG No. 20)
15		013	Program Specification (PRG No. 40)
16		014	General Purpose Input
17	Input	015	General Purpose Input
18		016	General Purpose Input
19		017	General Purpose Input
20		018	General Purpose Input
21		019	General Purpose Input
22		020	General Purpose Input
23		021	General Purpose Input
24		022	General Purpose Input
25		023	General Purpose Input
26		024	General Purpose Input
27		025	General Purpose Input
28		026	General Purpose Input
29		027	General Purpose Input
30		028	General Purpose Input
31		029	General Purpose Input
32		030	General Purpose Input
33		031	General Purpose Input
34		300	Alarm Output
35		301	Ready Output
36		302	Emergency Stop Output
37		303	General Purpose Output
38		304	General Purpose Output
39		305	General Purpose Output
40		306	General Purpose Output
41		307	General Purpose Output
42	Output	308	General Purpose Output
43		309	General Purpose Output
44		310	General Purpose Output
45		311	General Purpose Output
46		312	General Purpose Output
47		313	General Purpose Output
48		314	General Purpose Output
49		315	General Purpose Output
50		—	(J/P/Q type: 0V connection/K type: NC)

Extension I/O Signal Table (when N1 or P1 is selected)

Pin No.	Classification	Standard Settings
1		(J/P/Q type: 24V connection / K type: NC)
2		General Purpose Input
3		General Purpose Input
4		General Purpose Input
5		General Purpose Input
6		General Purpose Input
7		General Purpose Input
8		General Purpose Input
9		General Purpose Input
10		General Purpose Input
11		General Purpose Input
12		General Purpose Input
13		General Purpose Input
14		General Purpose Input
15		General Purpose Input
16		General Purpose Input
17	Input	General Purpose Input
18		General Purpose Input
19		General Purpose Input
20		General Purpose Input
21		General Purpose Input
22		General Purpose Input
23		General Purpose Input
24		General Purpose Input
25		General Purpose Input
26		General Purpose Input
27		General Purpose Input
28		General Purpose Input
29		General Purpose Input
30		General Purpose Input
31		General Purpose Input
32		General Purpose Input
33		General Purpose Input
34		General Purpose Output
35		General Purpose Output
36		General Purpose Output
37		General Purpose Output
38		General Purpose Output
39		General Purpose Output
40		General Purpose Output
41		General Purpose Output
42	Output	General Purpose Output
43		General Purpose Output
44		General Purpose Output
45		General Purpose Output
46		General Purpose Output
47		General Purpose Output
48		General Purpose Output
49		General Purpose Output
50		(J/P/Q type: 0V connection/K type: NC)

Extension I/O Signal Table (when N2 or P2 is selected)

Pin No.	Classification	Standard Settings
1		(J/P/Q type: 24V connection / K type: NC)
2		General Purpose Input
3		General Purpose Input
4		General Purpose Input
5		General Purpose Input
6		General Purpose Input
7		General Purpose Input
8		General Purpose Input
9	Input	General Purpose Input
10		General Purpose Input
11		General Purpose Input
12		General Purpose Input
13		General Purpose Input
14		General Purpose Input
15		General Purpose Input
16		General Purpose Input
17		General Purpose Input
18		General Purpose Output
19		General Purpose Output
20		General Purpose Output
21		General Purpose Output
22		General Purpose Output
23		General Purpose Output
24		General Purpose Output
25		General Purpose Output
26		General Purpose Output
27		General Purpose Output
28		General Purpose Output
29		General Purpose Output
30		General Purpose Output
31		General Purpose Output
32		General Purpose Output
33	Output	General Purpose Output
34		General Purpose Output
35		General Purpose Output
36		General Purpose Output
37		General Purpose Output
38		General Purpose Output
39		General Purpose Output
40		General Purpose Output
41		General Purpose Output
42		General Purpose Output
43		General Purpose Output
44		General Purpose Output
45		General Purpose Output
46		General Purpose Output
47		General Purpose Output
48		General Purpose Output
49		General Purpose Output
50		(J/P/Q type: 0V connection/K type: NC)

Standard Multipoint I/O Signal Table

■ Note: Dedicated to J (Compact) Type

Pin No.	Classification	Port No.	Standard Settings	
1	—	—	External Power Supply (DC24V) for Pin No. 2-25/ 51-74	
2	Input	000	Program Start	
3		001	General Purpose Input	
4		002	General Purpose Input	
5		003	General Purpose Input	
6		004	General Purpose Input	
7		005	General Purpose Input	
8		006	General Purpose Input	
9		007	Program Specification (PRG No.1)	
10		008	Program Specification (PRG No.2)	
11		009	Program Specification (PRG No.4)	
12		010	Program Specification (PRG No.8)	
13		011	Program Specification (PRG No.10)	
14		012	Program Specification (PRG No.20)	
15		013	Program Specification (PRG No.40)	
16		014	General Purpose Input	
17		015	General Purpose Input	
18		016	General Purpose Input	
19		017	General Purpose Input	
20		018	General Purpose Input	
21		019	General Purpose Input	
22		020	General Purpose Input	
23		021	General Purpose Input	
24		022	General Purpose Input	
25	023	General Purpose Input		
26	—	—	External Power Supply (DC24V) for Pin No. 27-50/ 76-99	
27	Input	024	General Purpose Input	
28		025	General Purpose Input	
29		026	General Purpose Input	
30		027	General Purpose Input	
31		028	General Purpose Input	
32		029	General Purpose Input	
33		030	General Purpose Input	
34		031	General Purpose Input	
35		032	General Purpose Input	
36		033	General Purpose Input	
37		034	General Purpose Input	
38		035	General Purpose Input	
39		036	General Purpose Input	
40		037	General Purpose Input	
41		038	General Purpose Input	
42		039	General Purpose Input	
43		040	General Purpose Input	
44		041	General Purpose Input	
45		042	General Purpose Input	
46		043	General Purpose Input	
47		044	General Purpose Input	
48		045	General Purpose Input	
49		046	General Purpose Input	
50		047	General Purpose Input	
51		Output	300	Alarm Output
52			301	Ready Output
53			302	Emergency Stop Output
54	303		General Purpose Output	
55	304		General Purpose Output	
56	305		General Purpose Output	
57	306		General Purpose Output	
58	307		General Purpose Output	
59	308		General Purpose Output	
60	309		General Purpose Output	
61	310		General Purpose Output	
62	311		General Purpose Output	
63	312		General Purpose Output	
64	313		General Purpose Output	
65	314		General Purpose Output	
66	315		General Purpose Output	
67	316		General Purpose Output	
68	317		General Purpose Output	
69	318		General Purpose Output	
70	319		General Purpose Output	
71	320		General Purpose Output	
72	321		General Purpose Output	
73	322		General Purpose Output	
74	323	General Purpose Output		
75	—	—	External Power Supply (0V) for Pin No. 2-25/ 51-74	
76	Output	324	General Purpose Output	
77		325	General Purpose Output	
78		326	General Purpose Output	
79		327	General Purpose Output	
80		328	General Purpose Output	
81		329	General Purpose Output	
82		330	General Purpose Output	
83		331	General Purpose Output	
84		332	General Purpose Output	
85		333	General Purpose Output	
86		334	General Purpose Output	
87		335	General Purpose Output	
88		336	General Purpose Output	
89		337	General Purpose Output	
90		338	General Purpose Output	
91		339	General Purpose Output	
92		340	General Purpose Output	
93		341	General Purpose Output	
94		342	General Purpose Output	
95		343	General Purpose Output	
96		344	General Purpose Output	
97		345	General Purpose Output	
98		346	General Purpose Output	
99		347	General Purpose Output	
100		—	—	External Power Supply (0V) for Pin No. 27-50/ 76-99

Expansion Multipoint I/O Signal Table

■ Note: Dedicated to J (General Purpose) Type

Pin No.	Classification	Port No.	Standard Settings	
1	—	—	External Power Supply (DC24V) for Pin No. 2-25/ 51-74	
2	Input	—	General Purpose Input	
3		—	General Purpose Input	
4		—	General Purpose Input	
5		—	General Purpose Input	
6		—	General Purpose Input	
7		—	General Purpose Input	
8		—	General Purpose Input	
9		—	General Purpose Input	
10		—	General Purpose Input	
11		—	General Purpose Input	
12		—	General Purpose Input	
13		—	General Purpose Input	
14		—	General Purpose Input	
15		—	General Purpose Input	
16		—	General Purpose Input	
17		—	General Purpose Input	
18		—	General Purpose Input	
19		—	General Purpose Input	
20		—	General Purpose Input	
21		—	General Purpose Input	
22		—	General Purpose Input	
23		—	General Purpose Input	
24		—	General Purpose Input	
25	—	General Purpose Input		
26	—	—	External Power Supply (DC24V) for Pin No. 27-50/ 76-99	
27	Input	—	General Purpose Input	
28		—	General Purpose Input	
29		—	General Purpose Input	
30		—	General Purpose Input	
31		—	General Purpose Input	
32		—	General Purpose Input	
33		—	General Purpose Input	
34		—	General Purpose Input	
35		—	General Purpose Input	
36		—	General Purpose Input	
37		—	General Purpose Input	
38		—	General Purpose Input	
39		—	General Purpose Input	
40		—	General Purpose Input	
41		—	General Purpose Input	
42		—	General Purpose Input	
43		—	General Purpose Input	
44		—	General Purpose Input	
45		—	General Purpose Input	
46		—	General Purpose Input	
47		—	General Purpose Input	
48		—	General Purpose Input	
49		—	General Purpose Input	
50		—	General Purpose Input	
51		Output	—	General Purpose Output
52			—	General Purpose Output
53			—	General Purpose Output
54	—		General Purpose Output	
55	—		General Purpose Output	
56	—		General Purpose Output	
57	—		General Purpose Output	
58	—		General Purpose Output	
59	—		General Purpose Output	
60	—		General Purpose Output	
61	—		General Purpose Output	
62	—		General Purpose Output	
63	—		General Purpose Output	
64	—		General Purpose Output	
65	—		General Purpose Output	
66	—		General Purpose Output	
67	—		General Purpose Output	
68	—		General Purpose Output	
69	—		General Purpose Output	
70	—		General Purpose Output	
71	—		General Purpose Output	
72	—		General Purpose Output	
73	—		General Purpose Output	
74	—	General Purpose Output		
75	—	—	External Power Supply (0V) for Pin No. 2-25/ 51-74	
76	Output	—	General Purpose Output	
77		—	General Purpose Output	
78		—	General Purpose Output	
79		—	General Purpose Output	
80		—	General Purpose Output	
81		—	General Purpose Output	
82		—	General Purpose Output	
83		—	General Purpose Output	
84		—	General Purpose Output	
85		—	General Purpose Output	
86		—	General Purpose Output	
87		—	General Purpose Output	
88		—	General Purpose Output	
89		—	General Purpose Output	
90		—	General Purpose Output	
91		—	General Purpose Output	
92		—	General Purpose Output	
93		—	General Purpose Output	
94		—	General Purpose Output	
95		—	General Purpose Output	
96		—	General Purpose Output	
97		—	General Purpose Output	
98		—	General Purpose Output	
99		—	General Purpose Output	
100		—	—	External Power Supply (0V) for Pin No. 27-50/ 76-99

Table of Specifications

J (Compact) / K (General Purpose)

Item	Description							
Controller Series, Type	J (Compact) Type				K (General Purpose) Type / KE (CE Compatible) Type			
Connecting actuator	RCS2 / ISA / ISPA / ISP / ISDA / ISDACR / ISPDACR / IF / FS / RS							
Compatible Motor Output (W)	20 / 30 / 60 / 100 / 150 / 200 / 300 / 400 / 600 / 750							
Number of control axes	1-axis	2-axis	3-axis	4-axis	1-axis	2-axis	3-axis	4-axis
Maximum Connected Axes Output (W)	Max. 800 (When power supply voltage is 200V) Max. 400 (When power supply voltage is 100V)				Max 800	Max. 1600 (When power supply voltage is 200V) Max. 800 (When power supply voltage is 100V)		
Input Voltage	100V Specification: Single-phase AC100 to 115V 200V Specification: Single-phase AC200 to 230V							
Motor Power Input	±10%							
Power Supply Frequency	50Hz/60Hz							
Power Supply Capacity	Max 1670VA	Max 1720VA	Max 1810VA	Max 1670VA	Max 3120VA	Max 3220VA	Max 3310VA	Max 3310VA
Position detection method	Incremental Encoder (Serial encoder) Absolute encoder with a rotational data backup (Serial encoder)							
Speed setting	1mm/sec and up, the maximum depends on actuator specifications							
Acceleration setting	0.01G and up, the maximum depends on the actuator							
Programming language	Super SEL language							
Number of programs	64 Programs							
Number of program steps	6,000 Steps (total)							
Number of multi-tasking programs	16 Programs							
Number of Positions	3,000 positions							
Data memory device	FLASH ROM+SRAM Battery Backup							
Data input method	Teaching pendant or PC software							
Standard Input/Output	32 points (total of dedicated inputs + general-purpose inputs) / 16 points (total of dedicated outputs + general-purpose outputs)							
Expansion Input/Output	None	48 points per unit (1 more unit can be installed)				48 points per unit (3 more units can be installed)		
Serial communications function	Teaching Port (25-pin D-sub) Standard Equipment				Teaching Pendant + Expansion SIO Board Installable (optional)			
Other Input/Output	System I/O (Emergency Stop Input, Enable Input, System Ready Output)							
Protection function	Motor overcurrent, Motor driver temperature check, Overload check, Encoder open-circuit check soft limit over, system error, battery error, etc.							
Ambient Operating Temp./Humidity	Temperature 0 to 40°C, Humidity 30 to 85%							
Ambient atmosphere	Free from corrosive gases. In particular, there shall be no significant dust.							
Weight	2.6kg	3.3kg	5.0kg	6.0kg	7.0kg			
Accessory	I/O Flat Cable							

P (Large-Capacity Standard Type) / Q (Large-Capacity Global Type)

Item	Description											
Controller Series, Type	P (Standard) Type						Q (Global) Type					
Connecting actuator	RCS2 / ISA / ISPA / ISP / ISDA / ISDACR / ISPDACR / IF / FS / RS / LSA											
Compatible Motor Output	20 / 30 / 60 / 100 / 150 / 200 / 300 / 400 / 600 / 750											
Number of Controlled Axes	1-axis	2-axis	3-axis	4-axis	5-axis	6-axis	1-axis	2-axis	3-axis	4-axis	5-axis	6-axis
Maximum Connected Axes Output (W)	Max 2400W (The single-phase AC200V specification is 1600W)											
Control Power Input	Single-phase AC170V to AC253V											
Motor Power Input	Single-phase/3-phase AC180V to AC253V						Single-phase/3-phase AC180V to AC253V					
Power Supply Frequency	50 / 60Hz											
Insulation Resistance	10MΩ or more (between the power-supply terminal and I/O terminals, and between all external terminals and case, at 500VDC)											
Withstand Voltage	AC1500V (1 minute)											
Power Supply Capacity (*1)	Max 1744VA	Max 3266VA	Max 4787VA	Max 4878VA	Max 4931VA	Max 4998VA	Max 1744VA	Max 3266VA	Max 4787VA	Max 4878VA	Max 4931VA	Max 4998VA
Position detection method	Incremental Encoder (Serial encoder) Absolute encoder with a rotational data backup (Serial encoder)											
Safety Circuit Configuration	Redundancy not supported						Double Redundant Enabled					
Drive Source Breaker System	Internal cutoff relay											
Enable Input	B Contact Input (Internal Power Supply Model)						B Contact Input (External Power Supply Model, Double Redundant)					
Speed setting	1mm/sec and up, the maximum depends on actuator specifications											
Acceleration/Deceleration Setting	0.01G and up, the maximum depends on the actuator											
Programming language	Super SEL language											
Number of programs	128 Programs											
Number of program steps	9,999 Steps (total)											
Number of multi-tasking programs	16 Programs											
Number of Positions	20,000 Positions (Total)											
Data memory device	FLASH ROM+SRAM Battery Backup											
Data input method	Teaching pendant or PC software											
Standard Input/Output	48-point I/O PIO Board (NPN/PNP), 96-point I/O PIO Board (NPN/PNP), 1 board can be installed											
Expansion Input/Output	48-point I/O PIO Board (NPN/PNP), 96-point I/O PIO Board (NPN/PNP), Up to 3 boards can be installed											
Serial communications function	Teaching Pendant (25-pin D-sub) Port + 2ch RS232C Port (9-pin D-sub x 2)											
Protection function	Motor overcurrent, overload, motor driver temperature check, overload check encoder open-circuit check, soft limit over, system error, battery error, etc.											
Ambient Operating Temp. Humidity, Atmosphere	0 to 40°C, 10 to 95% (non-condensing). Free from corrosive gases. In particular, there shall be no significant dust.											
Weight (*2)	5.2kg			5.7kg			4.5kg			5.0kg		
Accessory	I/O Flat Cable											

*1 When the connected axes represent the maximum wattage.

*2 Including the absolute-data backup battery, brake mechanism and expansion I/O box.

703 XSEL

Table of Specifications

R (High-functionality type) / S (Safety-category compliant, high-functionality type)

Item	Description	
	R Type	S Type
Controller Type		
Applicable motor output	12W to 750W	
Number of control axes	1 to 8 axes	
Maximum connected axes output	[Three-phase specification] 2400W max. [Single-phase specification] 1600W max.	[Three-phase specification] 2400W max. [Single-phase specification] 1600W max.
Control power-supply input	Single-phase AC200/230V ± 10%	
Power supply frequency	50/60 Hz	
Insulation resistance	10 MΩ or more (500-VDC reading between the power-supply terminal and I/O terminal, and between all external terminals and the case)	
Withstand voltage	AC1500 V (1 minute)	
Power-supply capacity (max.)	5094 VA (at the maximum output of connected axes)	
Position detection method	Only incremental/absolute encoders of serial communication type are supported (for all axes).	
Safety circuit configuration	Redundancy not supported	Double Redundant Enabled
Drive source breaker system	Internal cutoff relay	External safety circuit
Emergency stop input	B Contact Input (Internal Power Supply Model)	B Contact Input (External Power Supply Model, Double Redundant)
Enable input	B Contact Input (Internal Power Supply Model)	B Contact Input (External Power Supply Model, Double Redundant)
Speed setting	1 mm/sec and up, the maximum depends on the actuator specifications	
Acceleration/Deceleration setting	0.01 G and up, the maximum depends on the actuator specifications	
Programming language	Super SEL language	
Number of programs	128 programs	
Number of program steps	9,999 steps (total)	
Number of multi-tasking programs	16 programs	
Number of positions	Varies depending on the number of controlled axes. 6 axes: 20,000 positions, 8 axes: 16,000 positions (total)	
Data memory device	Flash ROM + non-volatile RAM (FRAM): System battery (button battery) not required	
Data input method	Teaching pendant or PC	
Standard input/output	2 boards can be installed, including a PIO board of 48 I/O points (NPN/PNP) and a PIO board of 96 I/O points (NPN/PNP)	
Expansion input/output	None (A separate expansion I/O unit can be used to add up to 4 PIO boards.)	
Serial communications function	Teaching port (D-sub 25 pins), 2-channel RS232C ports (D-sub 9 pins) Baud rate: 115.2 kbps max.	
IA net	Number of connected units: 64 controllers / Baud rate: 12 Mbps, fixed	
RC Gateway function	Channel 1 RS485 Port (D-sub 9 pins) or Channel 2 RS232C serial communication can be used. They cannot be used simultaneously.	
Fieldbus communication function	DeviceNet, CC-LINK, Profibus, EtherNet/IP, EtherCAT (One of EtherNet/IP and EtherCAT, and one of DeviceNet, CC-LINK and Profibus, can be supported at the same time.)	
Clock function	Retention time: Approx. 10 days Charge time: Approx. 100 hours	
Display unit	Optional panel unit (PU-1) can be connected.	
Regenerative resistance	Built-in regenerative resistor of 1 kΩ/20 W (External regenerative resistor unit(s) can be connected.)	
Absolute battery	AB-5 (built into the controller)	
Protection function	Motor overcurrent, overload, motor driver temperature check, overload check encoder open-circuit check, soft limit over, system error, battery error, etc.	
Ambient operating temp/humidity	0 to 40°C, 85% RH or less (non-condensing). Free from corrosive gases. In particular, there shall be no significant dust.	

* Refer to the operation manual or contact us for the power-supply capacity, etc.

- Controller
- PMEC
AMEC
- PSEP
ASEP
DSEP
- MSEP
- ERC3
- ERC2
- PCON
-CA
- PCON
- ACON
- SCON
-CA
- MSCON
- PSEL
- ASEL
- SSEL
- XSEL**
- PS-24
- Pulse Motor
- Servo Motor (24V)
- Servo Motor (200V)
- Linear Servo Motor

External Dimensions

■ J (Compact) Type / K (General Purpose) Type

	1-axis specification	2-axis specification	3/4-axis specification	Side View
J type (Compact Type)				
K type (General Purpose Type)	1/2-axis specification		3/4-axis specification	

■ P (high-capacity standard type) / Q (high-capacity global type)

The XSEL-P/Q types have different shapes and dimensions in accordance with the controller specifications (encoder type, with/without brake, and with/without I/O expansion).

The 4 layouts below are available. Confirm dimensions to match the desired type and number of axes.

Caution
The specifications of the single phase 200V in Q type is the exterior dimension of P type.

[P Type]

		Basic Layout (Incremental Specification)	With brake/absolute unit	Basic Layout + I/O expansion base	With brake/absolute unit + I/O expansion base	Side View
Controllers Specifications	Encoder	Incremental	Absolute	Incremental	Absolute	
	Brake	None	Yes	None	Yes	
	I/O	Standard only	Standard only	Standard + Expansion	Standard + Expansion	
Single phase Specifications	1 to 4 axis Specifications					
	5 to 6 axis Specifications					
3 phases Specifications	1 to 4 axis Specifications					
	5 to 6 axis Specifications					

705

XSEL

External Dimensional Drawing

[Q Type]

		Basic Layout (Incremental Specification)	With brake/absolute unit	Basic Layout + I/O expansion base	With brake/absolute unit + I/O expansion base	Side View
Controllers Specifications	Encoder	Incremental	Absolute	Incremental	Absolute	
	Brake	None	Yes	None	Yes	
	I/O	Standard only	Standard only	Standard + Expansion	Standard + Expansion	
Single phase Specifications	1 to 4 axis Specifications					
	5 to 6 axis Specifications					
3 phases Specifications	1 to 4 axis Specifications					
	5 to 6 axis Specifications					

External Dimensions

■ R (High-functionality type) / S (Safety-category compliant, high-functionality type)

		Front view		Side view
		Incremental specification	Absolute specification	
R (Note 1)	3-phase			
	Single-phase			
S (Note 1)	3-phase			
	Single-phase			

(Note 1) If any one of the connected axes is of absolute specification, the external dimensions for absolute specification shall apply.

Part Names

J type (Compact)

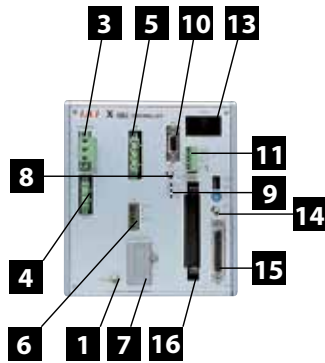

K type (General)

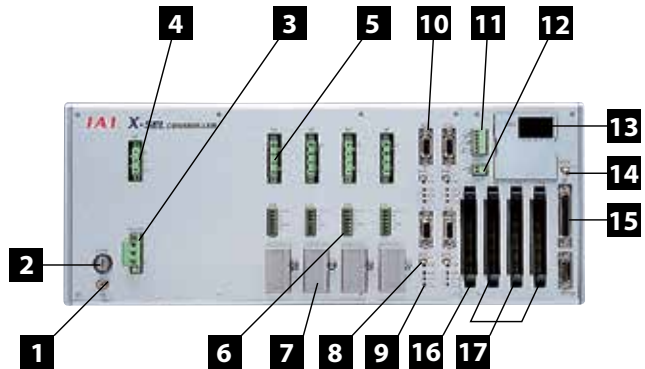

PMEC
AMEC

PSEP
ASEP
DSEP

MSEP

ERC3

ERC2

PCON
-CA

PCON

ACON

SCON
-CA

MSCON

PSEL

ASEL

SSEL

XSEL

PS-24

Pulse
Motor

Servo
Motor
(24V)

Servo
Motor
(200V)

Linear
Servo
Motor

1 FG Connection Terminal

A terminal for connecting to the FG terminal on the enclosure. The PE of the AC input are connected to the enclosure inside the controller.

2 FG Connection Terminal

This is the single-pole fuse holder for overcurrent protection in the AC input.

3 Main Power Input Connector

This connector is for the AC100/200V single-phase input.

4 Regeneration Resistance Unit Connector

This connector is for the regenerative resistance unit (optional/REU-1) that is connected when there is insufficient capacity with the built-in regenerative resistor for high-acceleration/high-loads, etc.

5 Motor Cable Connector

A connector for the motor power-supply cable of the actuator.

6 Actuator Sensor Input Connector

A connector for axis sensors such as LS, CREEP and OT.

7 Absolute-data backup battery

This is the encoder backup battery unit when an absolute encoder is used. This battery is not connected for a non-absolute axis.

8 Brake Release Switch (Brake-equipped specification only)

Locking toggle switch for releasing the axis brake. Pull the switch forward and then tilt it up or down. Set the switch to the top position (RLS) to forcibly release the brake, or to the bottom position (NOM) to have the brake automatically controlled by the controller.

9 Axis Driver Status LED

This LED is for monitoring the operating status of the driver CPU that controls the motor drive. Features the following three LEDs.

Name	Color	Function description
ALM	Orange	Indicates when an error has been detected by the driver.
SVON	Green	Indicates that the servo is ON and the motor is driven.
BATT ALM	Orange	Indicates low absolute battery charge.

10 Encoder sensor cable connector

15-pin D-sub connector for the actuator encoder cable.

11 System I/O Connector

A connector for three input/output points including two inputs used to for the controller operation, and one system status output.

Name		
EMG	Emergency stop input	ON=operation enabled, OFF=emergency stop
ENB	Safety Gate Input	ON=operation enabled, OFF=servo OFF
RDY	System Ready Relay Output	This signal outputs the status of this controller. Cascade connection is supported. Short=ready, Open=not ready

12 I/O 24V Power Connector (K Type only)

16, 17 This connector is for supplying external I/O power to the insulator when DIs and DOs are installed in the I/O boards.

13 Panel Window

This window has a 4-digit, 7-segment LED and five LED lamps showing the system status.

14 Mode switch

This is a locking toggle switch for designating the controller operating mode. Pull the switch forward and then tilt it up or down. The top position indicates the MANU (manual operation) mode, while the bottom position indicates the AUTO (automatic operation) mode. Teaching can only be performed in manual operation, and automatic operation using external I/Os is not possible in the MANU mode.

15 Teaching Connector

This is a 25-pin D-sub connector for connecting a teaching pendant or PC cable to enter programmed positions.

16 Standard I/O Slot (Slot 1)

A 32-point input / 16-point output PIO board is installed as standard equipment.

17 Expansion I/O Slots (Slot 2, Slot 3, Slot 4)

Install an expansion I/O board. (Option)

- Controller
- PMEC
AMEC
- PSEP
ASEP
DSEP
- MSEP
- ERC3
- ERC2
- PCON
-CA
- PCON
- ACON
- SCON
-CA
- MSCON
- PSEL
- ASEL
- SSEL
- XSEL**
- PS-24
- Pulse Motor
- Servo Motor (24V)
- Servo Motor (200V)
- Linear Servo Motor

Part Names

Type P (Standard 4-axis)

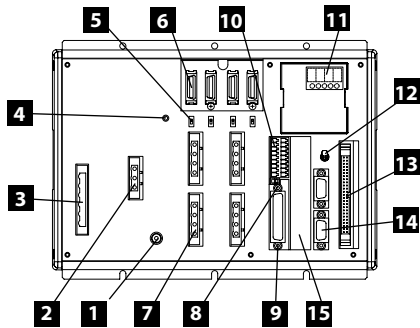

Type Q (Absolute brake unit + expansion base, 6-axis)

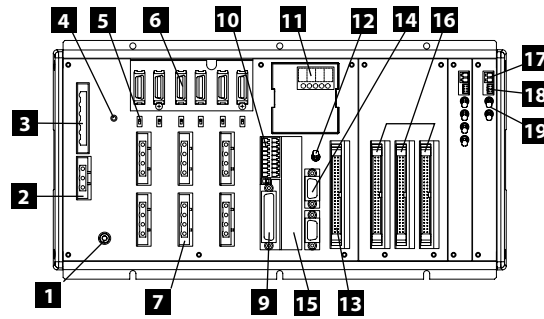

1 FG Connection Terminal

A terminal for connecting to the FG terminal on the enclosure. The PE of the AC input are connected to the enclosure inside the controller.

2 External regeneration unit connector

A connector for the regenerative resistor that must be connected when the built-in regenerative resistor alone does not offer sufficient capacity in high-acceleration/ high-load operation, etc. Whether or not an external regenerative resistor is necessary depends on the conditions of your specific application such as the axis configuration.

3 AC Power Input Connector

AC200V 3-phase input connector. It consists of six terminals including motor power-supply, control power-supply and PE terminals. Standard equipment only includes a terminal block. Due to risk of electrical shock, do not touch this connector while power is supplied.

4 Control Power Monitor LED

A green light illuminates while the control power supply is properly generating internal controller power.

5 Enable/Disable Switch for Absolute Battery

This switch is for enabling/disabling the encoder backup using the absolute data backup battery. The encoder backup has been disabled prior to shipment. After connecting the encoder/axis-sensor cables, turn on the power, and then set this switch to the top position.

6 Encoder/Axis Sensor Connector

A connector for axis sensors such as LS, CREEP and OT. *: LS, CREEP, and OT are options.

7 Motor connector

A connector for driving the motor in the actuator.

8 Teaching Pendant Type Selection Switch

This switch is for selecting the type of teaching pendant to connect to the teaching connector. Switch between an IAI standard teaching pendant and the ANSI-compatible teaching pendant. Operate the switch on the front face of the board in accordance with the teaching pendant used.

9 Teaching Connector

The teaching interface is used for connecting the IAI teaching pendant or the software on a PC to operate and configure the system, etc.

10 System I/O connector

A connector for managing the safety operation functions of the controllers. Controllers of the global specification let you configure a safety circuit conforming to safety categories of up to 4 using this connector and an external safety circuit.

11 Panel Window

This window consists of a 4-digit, 7-segment LED and five LED lamps showing the system status.

Description of five LEDs

Name	Status when LED is lit
RDY	CPU Ready (programs can be run)
ALM	CPU Power (System Down Level Error) CPU Hardware Problem
EMG	Emergency stop status, CPU hardware problem, or power system hardware problem
PSE	Power supply hardware problem
CLK	System clock problem

12 Mode switch

This is a locking toggle switch for designating the controller operating mode. Pull the switch forward and then tilt it up or down. The top position indicates the MANU (manual operation) mode, while the bottom position indicates the AUTO (automatic operation) mode. Teaching can only be performed in manual operation, and automatic operation using external I/Os is not possible in the MANU mode.

13 Standard I/O connector

50-pin flat connector structure, comprised of 32 input / 16 output DIOs.

Overview of Standard I/O Interface Specifications

Item	Details
Connector Name	I/O
Applicable connector	50-Pins, Flat Connector
Power Supply	Power is supplied through connector pins No. 1 and No. 50.
Input	32 points (including general-purpose and dedicated inputs)
Output	16 points (including general-purpose and dedicated inputs)
Connected to	External PLC, sensors, etc.

14 General-purpose RS232C Port Connector

This port is for connecting general-purpose RS232C equipment. (2-channels are available)

15 Field network board slot

A slot that accepts a fieldbus interface module.

16 Expansion I/O Board (optional)

Slots that accept optional expansion I/O boards.

17 Brake Power Input Connector

A power input connector for driving the actuator brake. DC 24V must be supplied externally. If this power supply is not provided, the actuator brake cannot be released. Be certain that power is supplied to the brake-equipped axis. Use a shielded cable for the brake power cable, and connect the shielding on the 24V power supply side.

18 Brake Release Switch Connector

This switch is for a connector for the switch that releases the actuator brake externally to the controller. Shorting the COM terminal and BKMRL* terminal of this connector will release the brake. Use this method if you wish to manually operate the actuator after the controller has experienced a power failure or malfunction.

19 Brake Switch

Locking toggle switch for releasing the axis brake. Pull the switch forward and then tilt it up or down. Setting it to the top position (RLS side) forcibly releases the brake, while setting it to the bottom position (NOM side) causes the controller to automatically control the brake.

Part Names

R type (High-functionality)

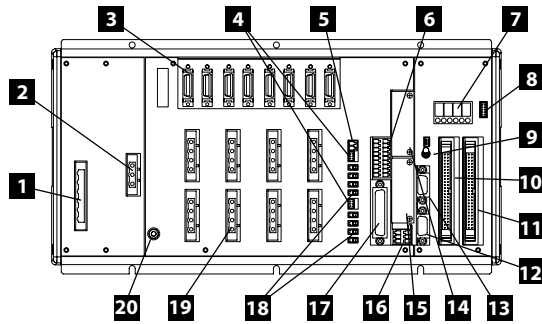

S type (Safety-category compliant, high-functionality)

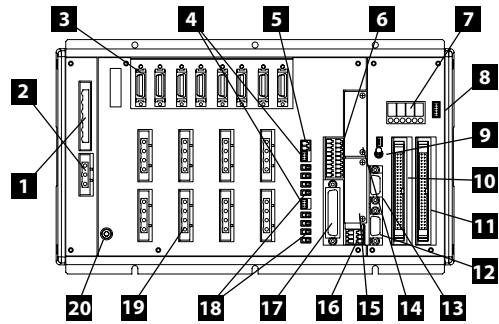

1 AC Power Input Connector

AC200V to 230V single or 3-phase input connector. It consists of six terminals including motor power-supply, control power-supply and PE terminals. Due to risk of electrical shock, do not touch this connector while power is supplied.

2 External Regeneration Unit Connector

This connector is used to connect a regenerative unit.

3 Encoder Connector

It is the connector to connect the actuator and encoder cable.

4 Brake Release Switch Connector

The signals of such as an external switch mounted externally to the controller are to be connected and the brake of the actuator equipped with a brake can compulsorily be released (Excitation release).

5 Brake Power Input Connector

It is a connector to connect the power supply for brake release for the actuator equipped with a brake. Supply 24V DC, 0.35A (per axis).

6 System I/O Connector

An I/O connector that controls the safety operations of the controller. With the S type (safety category compliant), a safety circuit complying with up to category 4 can be configured by having this connector and an external safety circuit.

7 Panel Window

This shows the controller status with four digits of seven-segment displays and six LED lamps.

8 Panel Unit Connector

This is a connector to connect Panel Unit PU-1 (option) for controller status display and error number display.

9 Mode Switch

This switch is used to specify an operation mode of the controller. It is a toggle switch with safety lever lock. Pull it towards you for operation.

Switch Position		Function
MANU (Manual Mode)	Upper	Teaching tool is activated.
AUTO (Automatic Mode)	Bottom Side	Teaching tool is inactivated. (Note) For S/SX/SD types, put the enclosed dummy plug to the teaching connector of 17. Unless it is plugged, the emergency stop would not be released.

10 I/O Slots 1

Either of PIO board (option) or RC Gateway fieldbus board (option) is to be inserted.

11 I/O Slots 2

PIO board (Option) is inserted.

12 General-purpose RS232C Port Connectors 1

This is a port for connections with external RS232C devices.

13 General-purpose RS232C Port Connectors 2

This is a port for connections with external RS232C devices. This port is to be used when using RC Gateway SIO functions (standard).

14 Field Network Board (option) Mounted Position 1

The EtherNet/IP or EtherCAT Field Network Board (option) is to be mounted.

15 Field Network Board (option) Mounted Position 2

The CC-Link, DeviceNet or PROFIBUS-DP Field Network Board (option) is to be mounted.

16 IA Net Connector

In the case that the IA net (option) function is to be added, the dedicated connector is attached. This connector is to be used for connections of IA-Net and expansion I/O units.

17 Teaching Connector

This is a connector to connect a teaching pendant or PC (PC software) for teaching tools to have operation and setting of actuators.

18 Brake Release Switch

This is a switch to compulsorily release (excitation release) the brake of the actuator equipped with a brake. The brake can be compulsorily released by putting the switch on RLS side when a manual operation of an actuator is required for the system startup, teaching or in an error occurrence. Unless otherwise necessary, set the switch on NOM side.

Switch Position		Function
RLS (Brake Release)	Left Side	To release the brake compulsorily
NOM (Automatic Mode)	Right Side	Brake is controlled automatically by the controller. Servo ON : Brake release Servo OFF : Brake is activated

Warning

After having a brake compulsory release, make sure to set back on NOM (Automatic Mode) so the automatic control of the brake by the controller can be executed. It is extremely risky to leave it on RLS (brake release) status because the brake would not work when in emergency stop or the servo is turned OFF. For a vertically mounted actuator, slider or rod may drop and cause a critical accident.

19 Motor Cable Connector

It is the connector to connect the actuator motor cable.

20 FG (Frame Ground) Connection Terminal

This connection terminal is used to connect the FG point on the enclosure to ground. Make sure to ground properly for noise proof reasons.

PMEC
AMEC

PSEP
ASEP
DSEP

MSEP

ERC3

ERC2

PCON
-CA

PCON

ACON

SCON
-CA

MSCON

PSEL

ASEL

SSEL

XSEL

PS-24

Pulse
Motor

Servo
Motor
(24V)

Servo
Motor
(200V)

Linear
Servo
Motor

- Controller
- PMEC AMEC
- PSEP ASEP DSEP
- MSEP
- ERC3
- ERC2
- PCON -CA
- PCON
- ACON
- SCON -CA
- MSCON
- PSEL
- ASEL
- SSEL
- XSEL
- PS-24
- Pulse Motor
- Servo Motor (24V)
- Servo Motor (200V)
- Linear Servo Motor

Options

Regenerative Resistance Unit

Model RESU-1 (Standars specification, second or subsequent unit)
RESUD-1 (DIN rail mount specification, second or subsequent unit)

Features This unit converts regenerative current that generates when the motor decelerates, to heat. Check the total wattage of the actuators to be operated and provide a regenerative resistance unit or units if required.

* Please see MSCON section page 662 for specification information and drawings.

Installation Standards Determined by the total motor capacity of vertical axes connected.

Horizontal Application

Number of connecting units	P/Q Type	J Type	K Type
0 pc	~ 100W	~ 200W	~ 800W
1 pc	~ 600W	~ 800W	~ 1200W
2 pc	~ 1200W	—	~ 1600W
3 pc	~ 1800W	—	—
4 pc	~ 2400W	—	—

Vertical Application

Number of connecting units	P/Q Type	J Type	K Type
0 pc	~ 100W	~ 200W	~ 400W
1 pc	~ 600W	~ 600W	~ 800W
2 pc	~ 1000W	~ 800W	~ 1200W
3 pc	~ 1400W	—	When exceeding 1200W, please contact IAI.
4 pc	~ 2000W	—	
5 pc	~ 2400W	—	

Absolute Data Retention Battery (For XSEL-J/K/KE/KT/KET)

Model IA-XAB-BT

Features A battery that retains the data stored in an absolute type controller. Replace when the controller battery alarm illuminates.

Packaging 1 Unit (One battery is required for each axis. Specify a quantity for the number of axes used.)



Expansion SIO Board (General-Purpose Type)

Model/Specifications IA-105-X-MW-A (for RS232C connection) (Board + joint cables (1), 2 included)
 IA-105-X-MW-B (for RS422 connection) (Board + joint cables (2), 1 included)
 IA-105-X-MW-C (for RS485 connection) (Board + joint cables (2), 1 included)

Details Board for serial communications with external equipment. This board has two port channels and implements three communication modes using the supplied joint cable (s).

Absolute Data Retention Battery (For XSEL-P/Q)

Model AB-5

Features Absolute data retention battery for operating actuators under absolute specification.



Joint cable ① Model: CB-ST-232J001

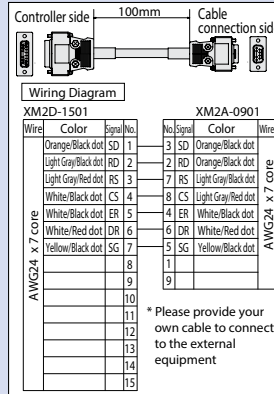

Joint cable ② Model: CB-ST-422J010

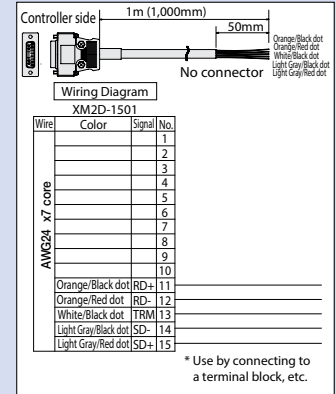

Expansion PIO Board

Details An optional board for adding I/O (input/output) points. With the general-purpose and large-capacity types, up to three expansion PIO boards can be installed in the expansion slots. (With the compact types, only one expansion PIO board can be installed in the expansion slot, provided that the controller is of 3 or 4-axis specification.)

Field Network Connection Board

Model DV/CC/PR/EP/EC (* Specify in the controller model description)

Details By selecting a field network option in the controller I/O type, the corresponding field network board will be installed to the I/O slot.

< Network Correspondence Table >

	DeviceNet	CC-Link	PROFIBUS-DP	Ethernet	EtherNet/IP	EtherCAT
XSEL-J/K	●	●	●	●		
XSEL-P/Q	●	●	●	●	●	
XSEL-R/S	●	●	●		●	●

RC Gateway function (DeviceNet specification/ SIO specification)

Features Up to 16 actuator axes can be operated with a XSEL controller program, with the XSEL controller acting as the master and each ROBO Cylinder controller as a slave.

One of the following two methods can be selected for communication among the controllers.

Type	Comm. method	Comm. speed	How to use
DeviceNet specification	DeviceNet	500 kbps	The DeviceNet Gateway master board must be installed in an I/O slot of the XSEL controller. Specify "DG" as the I/O slot type for the XSEL controller.
SIO specification	RS232C	230.4 kbps	Use the 2-channel communication port (standard equipment) of the XSEL controller. To connect slave controllers, the dedicated 2-channel connection port cable is needed. (Model: CB-RS-SIO005, length 0.5m)

* Contact us for the wiring and setting methods for the RC Gateway function.

Able to operate axes connected to MCON, MSEP and/or PCON/ACON/SCON-CA controllers from an XSEL controller using its program.

Up to 16 axes can be operated.

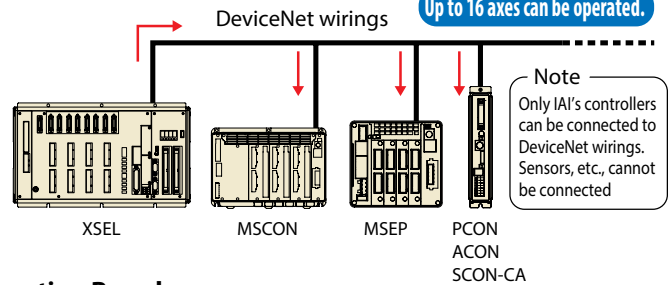

ROBO Cylinder Gateway (DeviceNet specification) Connection Board

Model **DG** (* Specify in the controller model description)

Details (*Dedicated to XSEL-R/S)

The network board for using the ROBO Cylinder gateway function with the DeviceNet specification XSEL-R/S controllers.

ROBO Cylinder Gateway SIO Connection Unit

Model **RCB-CV-GW** (RS232 conversion unit)
CB-RCB-SIO050 (Communication cable)
CB-RCB-CTL (Controller link cable)

Details

The connection unit to be required for using the ROBO Cylinder gateway function with the XSEL-P/Q/R/S controllers.

An RS232 conversion unit, and a communication cable are required for each XSEL controller.

The required number of controller link cable corresponds to the number of ROBO Cylinder controller to be connected. (See the diagram to the right)

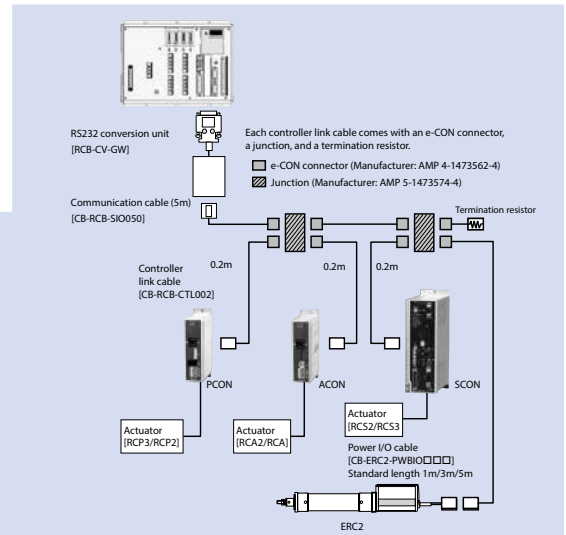

IA Net Function

Features XSEL controllers can be interconnected via network to perform I/O communication between the controllers. I/Os can be added using the expansion I/O unit.

Connection Board for IA Net

Model **IA** (* Specify in the controller model description)

Details

(*Dedicated to XSEL-R/S)

The network board for using the IA net or expansion I/O unit.

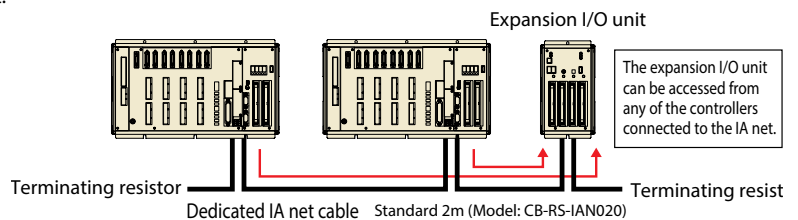

Expansion I/O Unit

- ① Up to four expansion I/O boards can be added. (For the I/Os, up to 192 input points/192 output points can be added.)
 - ② The expansion I/O unit can be shared by multiple XSEL controllers(*).
 Note: Input signals from one expansion I/O board can be shared by multiple controllers, but output signals from one expansion I/O board should be used by only one controller.
- (*Dedicated to XSEL-R/S)
- * If the expansion I/O unit is used, select "IA net-compatible" when specifying the controller model.

Model **EIOU-4**-(Slot 1 code) (Slot 2 code) (Slot 3 code) (Slot 4 code)
 * Enter in each slot code field the code of the expansion I/O board to be added to the expansion I/O unit.

<Expansion I/O board codes>

E	Not used	N1	Input 32/Output 16 (NPN)	P1	Input 32/Output 16 (PNP)
		N2	Input 16/Output 32 (NPN)	P2	Input 16/Output 32 (PNP)
		N3	Input 48/Output 48 (NPN)	P3	Input 48/Output 48 (PNP)

Accessory Cable dedicated for IA net 2m (Model: CB-RS-IAN020)

External dimensional drawing

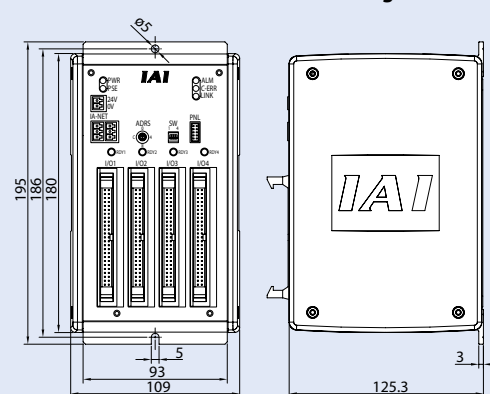

- Controller
- PMEC
AMEC
- PSEP
ASEP
DSEP
- MSEP
- ERC3
- ERC2
- PCON
-CA
- PCON
- ACON
- SCON
-CA
- MCON
- PSEL
- ASEL
- SSEL
- XSEL
- PS-24
- Pulse Motor
- Servo Motor (24V)
- Servo Motor (200V)
- Linear Servo Motor

Options

ANSI standard / CE mark compatible teaching pendant (dedicated to general purpose type)

- Model** **SEL-T**
SEL-TD ANSI compliant
SEL-TD-26H Safety-category compliant, for PSEL/ASEL/SSEL
SEL-TD-25 Safety-category compliant, for XSEL

Dimensions

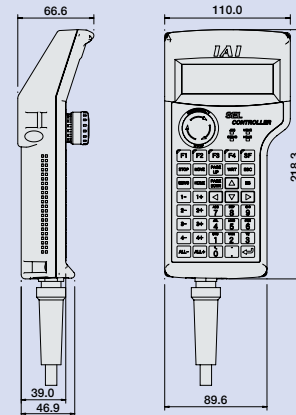

Features Splash-proof type that corresponds to protection level IP54. Improved operationability with separate keys for different functions. In addition, SEL-TD / SEL-TG has a 3-position enable switch and corresponds to ANSI standard.

Specifications

Item	Specifications
Ambient Operating Temp./Humidity	Temperature: 0 to 40°C Humidity: 30 to 85%RH or lower (non-condensing)
Protection mechanism	IP54 (Cable connector excluded)
Weight	400g or lower (Cable connector excluded)
Cable Length	5m
Indication	32 characters x 8 lines LCD display
Safety Rating	CE mark, ANSI standard (*)

(*) only SEL-TD / SEL-TG corresponds to ANSI standard.

Teaching pendant - controller correspondence table

		SEL-T	SEL-TD	SEL-TD-26H/SEL-TD-25
		Splash-proof type	ANSI compliant splash-proof type	Safety-category compliant type
Program Controllers	PSEL/ASEL/SSEL	○ (Note 1)	○ (Note 1)	◎
	XSEL-J	×	×	○ (Note 2)
	XSEL-K	○	○	○
	XSEL-P	○	○	○
	XSEL-Q	○	◎	◎
	XSEL-KT	○	◎	◎
	XSEL-KE	○	○	○

◎ corresponds to safety category B to 4.

○ does not correspond to safety category, but connection is available.

(Note 1) To connect to PSEL/ASEL/SSEL, a conversion cable is necessary.

(Note 2) To connect SEL-TG to the XSEL-J/JX controller, DC24V needs to be applied to TP adaptor.

Wiring drawing

* SEL-TD can be directly connected to the controller. SEL-TG connects to the controller via the TP adaptor.
 Function of the teaching pendant bodies are the same.

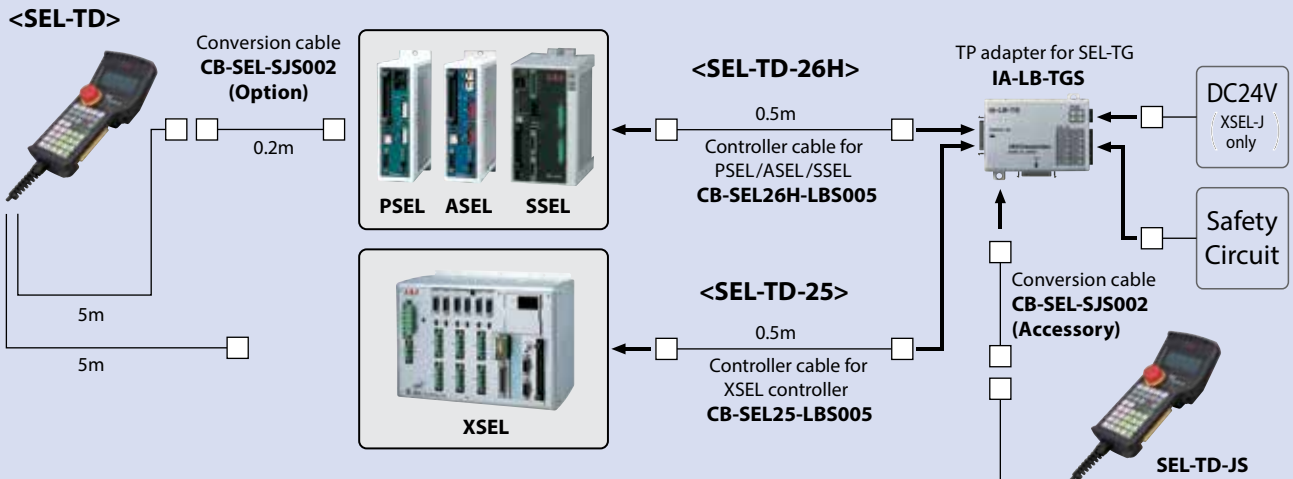

Details

The structures of following model options are as follows.

<Model: SEL-TD-26H>

- Teaching pendant <Model: SEL-TD-JS>
- TP adapter for SEL <Model: IA-LB-TGS>
- Controller connection cable <Model: CB-SEL26H-LBS005>
- Dummy plug <Model: DP-4S>

<Model: SEL-TD-25>

- Teaching pendant <Model: SEL-TD-JS>
- TP adapter for SEL <Model: IA-LB-TGS>
- Controller connection cable <Model: CB-SEL25H-LBS005>
- Dummy plug <Model: DP-4S>

PC software (Windows dedicated)

Model IA-101-X-MW (DOS/V ver.)

Note
 * Versions older than 3.0.0 cannot be used with XSEL-P/Q.
 * Versions older than 2.0.0 cannot be used with SCARA.
 * Please use IA-101-XA-MW for safety category 4-compliant controller.
 * Cannot be used with XSEL-Q/QX types.

Features A startup support software program offering program/position input function, test operation function, monitoring function, and more. The functions needed for debugging have been enhanced to help reduce the startup time.

Details Software (CD-ROM)
 (Supported Windows OS: 2000 SP4 or later / XP SP2 or later / Vista / 7)
 PC connecting cable 5m + Emergency stop box (Model: CB-ST-E1MW050-EB)

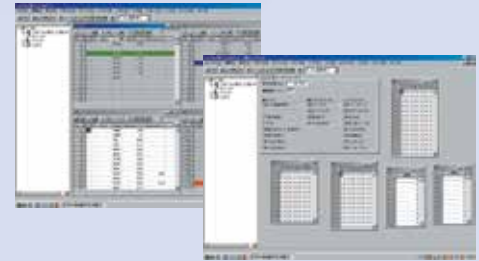

PC connecting cable single unit (Model: CB-ST-E1MW050)

Note
 When ordering a separate replacement PC cable, the model number for cable only is CB-ST-E1MW050, and for cable with emergency stop box is CB-ST-E1MW050-EB.

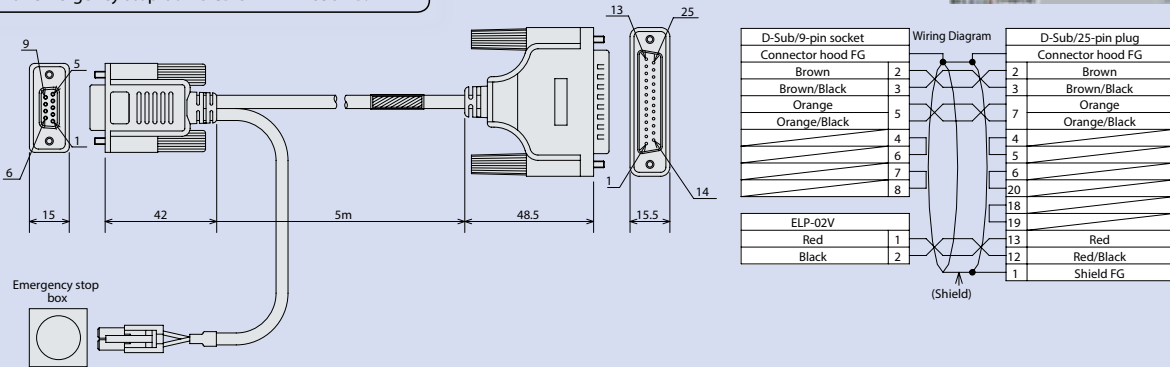

Safety Category 4-compatible PC Software

Model IA-101-XA-MW (DOS/V version)

Features A startup support software program offering program/position input function, test operation function, monitoring function, and more. The functions needed for debugging have been enhanced to help reduce the startup time. PC connecting cable is compatible to safety category 4 by duplicating the emergency stop circuits.

* The software is dedicated to the XSEL-KT/KET/Q/QX. It cannot be used with any other controllers.

Details Software (CD-ROM)
 (Supported Windows OS: 2000 SP4 or later / XP SP2 or later / Vista / 7)
 PC connecting cable 5m + Emergency stop box (Model: CB-ST-A1MW050-EB)

Dimensions PC connecting cable (Model: CB-ST-A1MW050)

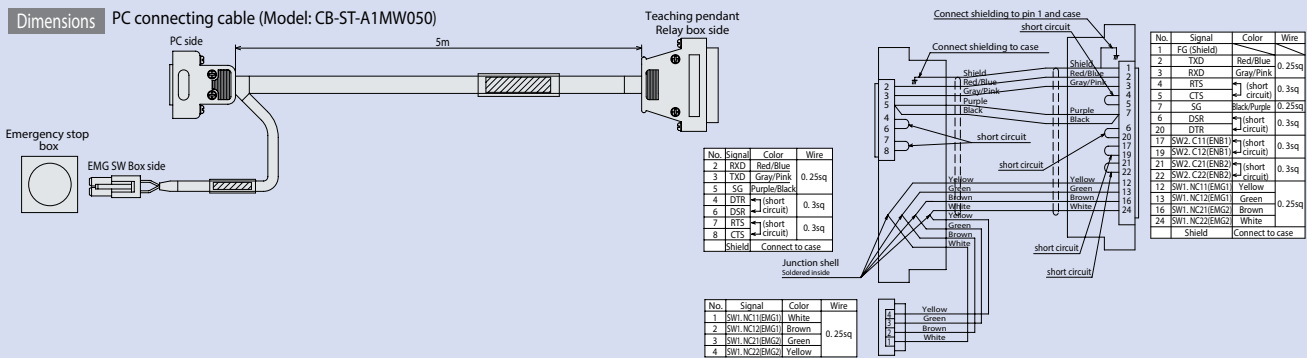

USB-compatible PC software

Model IA-101-X-USBMW

Features Software available by PC USB port by connecting a USB conversion adaptor to a RS232C cable.

Details Software (CD-ROM)
 (Supported Windows OS: 2000 SP4 or later / XP SP2 or later / Vista / 7)
 PC connecting cable 5m + Emergency stop box + USB conversion adaptor + USB cable 3m

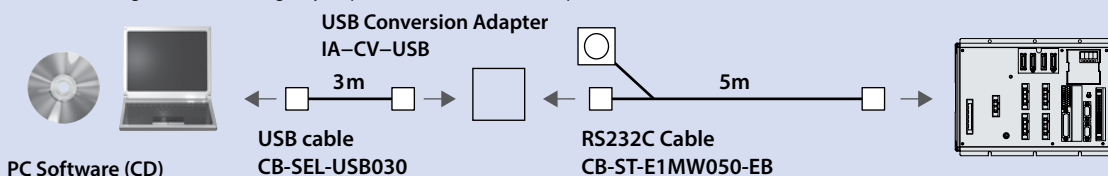

Spare Parts

When you need spare parts after purchasing the product, such as when replacing a cable, refer to the list of models below.

Motor cable/Motor robot cable

Model **CB-RCC-MA** / **CB-RCC-MA** **-RB**

* Enter the cable length (L) into . Compatible to a maximum of 30 meters.
Ex.: 080 = 8m

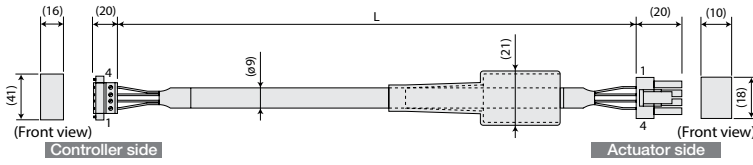

Wire	Signal	No.	No.	Signal	Wire
0.75sq	PE	1	1	U	0.75sq (crimped)
	U	2	2	V	
	V	3	3	W	
	W	4	4	PE	

Min. bend radius $r = 50\text{mm}$ or larger (when movable type is used)
* Only the robot cable is to be used in a cable track

Encoder cable/Encoder robot cable (for XSEL-J/K)

Model **CB-RCBC-PA** / **CB-RCBC-PA** **-RB**

* Enter the cable length (L) into . Compatible to a maximum of 30 meters.
Ex.: 080 = 8m

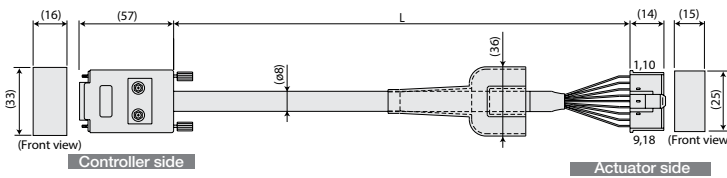

Wire	Signal	No.	No.	Signal	Wire
0.15sq (crimped)	A/U	1	1	A/U	0.15sq (crimped)
	A/U	2	2	A/U	
	B/V	3	3	B/V	
	B/V	4	4	B/V	
	Z/W	5	5	Z/W	
	Z/W	6	6	Z/W	
	SD	7	7	-	
	SD	8	8	-	
	BAT+	9	9	FG	
	BAT-	10	10	SD	
	VCC	11	11	SD	
	GND	12	12	BAT+	
	BK-	13	13	BAT-	
	BK+	14	14	VCC	
	-	15	15	GND	
The shield is connected to the hood by a clamp.			16	-	
Ground wire and shield braiding			17	BK-	
			18	BK+	

Min. bend radius $r = 50\text{mm}$ or larger (when movable type is used)
* Only the robot cable is to be used in a cable track

Encoder cable/Encoder robot cable (for XSEL-P/Q)

Model **CB-RCS2-PA** / **CB-X3-PA**

* Enter the cable length (L) into . Compatible to a maximum of 30 meters.
Ex.: 080 = 8m

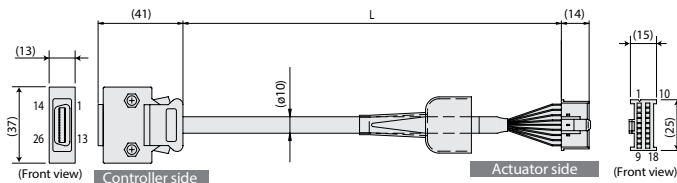

Wire	Color	Signal	No.	No.	Signal	Color	Wire
AWG26 (soldered)	-	-	10	1	A	Pink	AWG26 (crimped)
	-	-	11	2	A	Purple	
	-	E24V	12	3	B	White	
	Gray/White	OV	13	4	B	Blue/red	
	Brown/White	LS	26	5	Z	Orange/White	
	-	CREEP	25	6	Z	Green/White	
	-	OT	24	7	LS+	Brown/White	
	-	RSV	23	8	-	-	
	-	-	9	9	FG	Ground	
	-	-	18	10	SD	Blue	
	-	-	19	11	SD	Orange	
	Pink	A+	1	12	BAT+	Black	
	Purple	A-	2	13	BAT-	Yellow	
	White	B+	3	14	VCC	Green	
	Blue/red	B-	4	15	GND	Brown	
	Blue/White	Z+	5	16	LS	Gray/White	
	Green/White	Z-	6	17	BK-	Gray	
	Blue	SRD+	7	18	BK+	Red	
	Orange	SRD-	8				
	Black	BAT+	14				
	Yellow	BAT-	15				
	Green	VCC	16				
Brown	GND	17					
Gray	BKR-	20					
Red	BKR+	21					
-	-	22					
The shield is connected to the hood by a clamp.							
Ground wire and shield braiding							

Min. bend radius $r = 50\text{mm}$ or larger (when movable type is used)
* Only the robot cable is to be used in a cable track

Spare Parts

Rotary Dedicated Encoder Cable / Encoder Robot Cable

Model **CB-RCS2-PLA** / **CB-X2-PLA**

* Enter the cable length (L) into . Compatible to a maximum of 30 meters.
Ex.: 080 = 8m

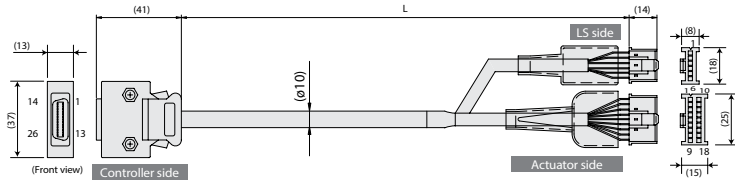

Min. bend radius $r = 50$ mm or larger (when movable type is used)
* Only the robot cable is to be used in a cable track

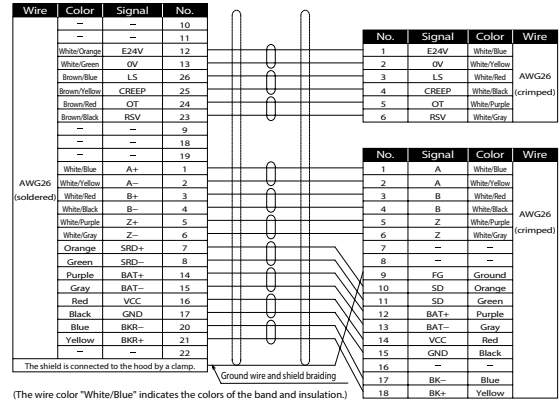

Encoder cable (when using a XSEL-J/K type a homing sensor is used)

Model **CB-RCBC-PLA**

* Enter the cable length (L) into . Compatible to a maximum of 30 meters.
Ex.: 080 = 8 m

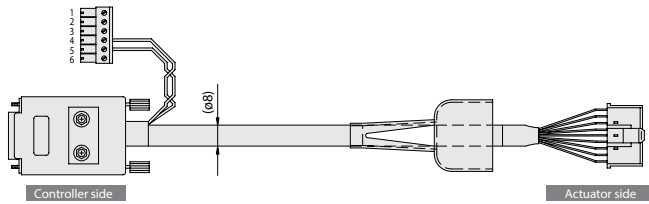

*This cable is a standard type.

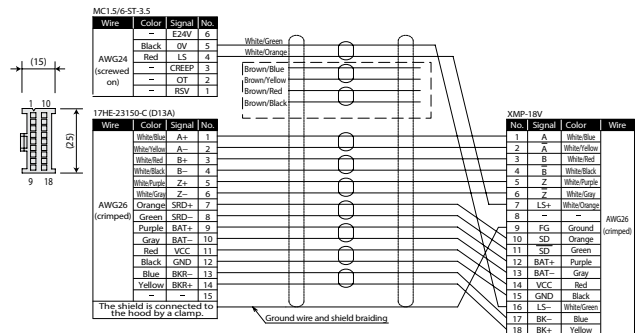

I/O flat cable (for XSEL-J/K/P/Q)

Model **CB-X-PIO**

* Enter the cable length (L) into . Compatible to a maximum of 10 meters.
Ex.: 080 = 8 m

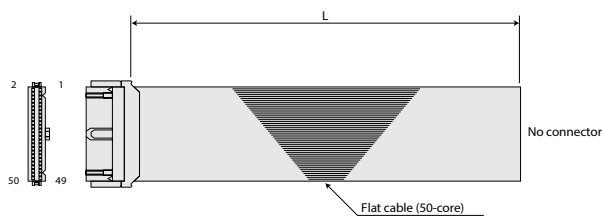

Number	Color	Wire	Number	Color	Wire	Number	Color	Wire
1	Brown 1	Flat cable crimped	18	Gray 2	Flat cable crimped	35	Green 4	Flat cable crimped
2	Red 1		19	White 2		36	Blue 4	
3	Orange 1		20	Black 2		37	Purple 4	
4	Yellow 1		21	Brown-3		38	Gray 4	
5	Green 1		22	Red 3		39	White 4	
6	Blue 1		23	Orange 3		40	Black 4	
7	Purple 1		24	Yellow 3		41	Brown-5	
8	Gray 1		25	Green 3		42	Red 5	
9	White 1		26	Blue 3		43	Orange 5	
10	Black 1		27	Purple 3		44	Yellow 5	
11	Brown-2		28	Gray 3		45	Green 5	
12	Red 2		29	White 3		46	Blue 5	
13	Orange 2		30	Black 3		47	Purple 5	
14	Yellow 2		31	Brown-4		48	Gray 5	
15	Green 2		32	Red 4		49	White 5	
16	Blue 2		33	Orange 4		50	Black 5	
17	Purple 2		34	Yellow 4				

- Controller
- PMEC
AMEC
- PSEP
ASEP
DSEP
- MSEP
- ERC3
- ERC2
- PCON
-CA
- PCON
- ACON
- SCON
-CA
- MSCON
- PSEL
- ASEL
- SSEL
- XSEL
- PS-24

PS-24



■ Model PS-241/PS-242

DC24V Power supply for ROBO Cylinder

Features

1 Maximum Momentary Output of 17A

Up to 17A of maximum momentary output current is possible at 8.5A rated output current. This lets you select an appropriate power-supply capacity based on the total rated current of actuators, without having to consider the maximum momentary current that may be generated by the actuators during acceleration. Because you no longer need to use an expensive high-capacity power supply, cost can be reduced substantially.

*The maximum momentary output current must be considered if the actuator operating conditions are tight. See the "Selection Guide" at right for details.

2 Parallel Operation Enabled

Up to 5 units can be operated in parallel. Therefore, even if the power capacity is insufficient with one unit, this can be easily remedied by adding one unit, without the need to replace the unit with a larger capacity power supply.

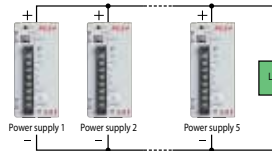

3 Load Detection Function

Load percentage can be detected by the RDY (Ready) display lamp and the RDY output signal.

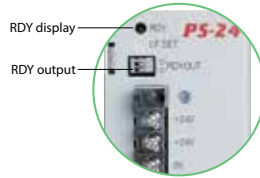

Table 1. PS-24 Rated Current and Allowable Maximum Momentary Electric Current

No. of Connected units	Rated current [A]	Max. momentary current [A]
1	8.5	17
2	15.5	30.6
3	22.95	45.9
4	30.6	61.2
5	38.25	76.5

Note: For the second and subsequent units, add a 10% safety buffer (loss).

Selection target Number of actuators connected

When selecting a power-supply unit for operating multiple actuators, normally a unit with a capacity equal to or exceeding the total maximum current of all actuators is chosen. However, actuators generate their maximum current only momentarily during acceleration, etc., and in many cases the power-supply is over-specified.

On the other hand, the PS-24 power supply provides the following advantages:

1. Supporting maximum momentary current of up to twice the rated current.
2. If you need more power-supply capacity, you can simply add an extra unit or units.

The above features let you select an optimal power-supply capacity.

Number of Power-Supply Units

Basically, how many power-supply units you need should be determined in such a way that the total rated current of all actuators will remain within the rated current of the PS-24. If the load condition is tight, however, the power-supply capacity may still become inadequate. In such cases, add an extra power supply or supplies.

"Severe load conditions" refers to:

- Large load (load is approaching the rated load capacity)
- High acceleration/deceleration
- High speed
- Simultaneous operation of multiple axes
- Use of the RCS2-SRA7 series (Structurally these actuators allow maximum current to flow for a longer period).

Table 2. Actuator vs. Power Supply Current

Controller type	Actuator type	Motor type	Power supply current [A]	
ACON ASEL ASEP	RCA	SA4, SA5, RA4 (20W) type	Rated	1.3
		SA6, RA4 (30W) type	Maximum	4.4
		RA3 (20W) type	Rated	1.3
		RA3 (20W) type	Maximum	4.0
		RA3 (20W) type	Rated	1.7
		RA3 (20W) type	Maximum	5.1
	RCA2	SA2A□ (5W) type	Rated	1.0
		SA2A□ (5W) type	Maximum	6.4
		SA3 (10W) type	Rated	1.3
		SA3 (10W) type	Maximum	4.4
		SA5, TA6 (20W) type	Rated	1.3
		SA5, TA6 (20W) type	Maximum	4.4
		RN3N, RP3N, GS3N, GD3N, SD3N TCA3N, TWA3N, TFA3N, TA4C, TA4R (10W) type	Rated	1.3
		RN3N, RP3N, GS3N, GD3N, SD3N TCA3N, TWA3N, TFA3N, TA4C, TA4R (10W) type	Maximum	4.4
		SA6, TA7 (30W) type	Rated	1.3
		SA6, TA7 (30W) type	Maximum	4.4
		RA4, TA5 (20W) type	Rated	1.7
		RA4, TA5 (20W) type	Maximum	5.1
RN4N, RP4N, GS4N, GD4N, SD4N TCA4N, TWA4N, TFA4N (20W) type	Rated	1.7		
RN4N, RP4N, GS4N, GD4N, SD4N TCA4N, TWA4N, TFA4N (20W) type	Maximum	5.1		
RCL	RA1L, SA1L (2W) type	Rated	0.8	
	RA1L, SA1L (2W) type	Maximum	4.6	
	RA2L, SA2L (5W) type	Rated	1.0	
	RA2L, SA2L (5W) type	Maximum	6.4	
	RA3L, SA3L (10W) type	Rated	1.3	
	RA3L, SA3L (10W) type	Maximum	6.4	
PCON PSEL PSEP MSEP	RCP2 RCP3	20P	Rated	0.4
		20P	Maximum	2.0
		28P	Rated	0.4
		28P	Maximum	2.0
		35P	Rated	1.2
		35P	Maximum	2.0
PCON-CA	RCP4	42P	Rated	1.2
		42P	Maximum	2.0
		56P	Rated	1.2
		56P	Maximum	2.0
		42P, 56P High-output setting disabled	Rated	3.5
		42P, 56P High-output setting disabled	Maximum	4.2
PCON-CFA	RCP2	60P, 86P	Rated	2.2
		60P, 86P	Maximum	6.0
DSEP	RCD	RCD (2.5W)	Rated	0.7
		RCD (2.5W)	Maximum	1.5
ERC2		SA6, SA7, RA6, RA7	Rated	2.2
		SA6, SA7, RA6, RA7	Maximum	3.5
ERC3		SA5, SA7, RA5, RA6 High-output setting disabled	Rated	4.2
		SA5, SA7, RA5, RA6 High-output setting disabled	Maximum	2.2

Model/Standard Price

Model	PS-241	PS-242
Standard Price	—	—

717 PS-24

Names

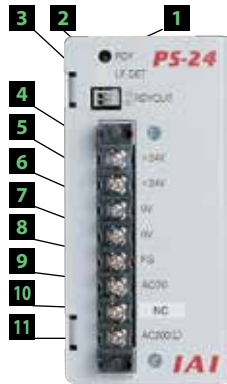

- 1** Ready indicating light (RDY)
- 2** Level setting dial for over load detection (L.F.DET)

*Appropriate value settled at shipment. Operation not needed.

- 3** Ready output signal (RDYOUT)
- 4 5** +24V Output terminal (+24V)
- 6 7** 0V Output terminal (0V)

*45 connected internally.

*67 connected internally.

- 8** Frame ground terminal (FG)

Terminal for ground.

- 9** AC input terminal (AC (N))

- 10** AC input terminal (AC100V) (AC100 (L))

- 11** AC input terminal (AC200V) (AC200 (L))

*AC100V input type should be connected to 9 and 0 interval, AC200V to 9 and A. Unavailable for combined use.

Specification List

Item	PS-241	PS-242
Rated DC output voltage	24V±10% (varied depending on the load)	
Rated DC output current	8.5A	
Instantaneous max. output current	17A	
Rated output capacity	204W	
Efficiency	80%	80%
Rated input (frequency)	AC100~115V (50/60Hz)	AC200~230V (50/60Hz)
Input voltage range	AC85~125V	AC170~250V
Input current	3.50A (100VAC full load)	1.80A (200VAC full load)
Output holding time	20 [msec] (Ambient temperature 25°C under rated input/output condition)	
Protection circuit	Protection from overcurrent, overvoltage, overheating and overload.	
Parallel operation	Possible	
Operating temperature	0~50°C (derated)	
Operating humidity	30~85%RH (non-condensing)	
Cooling method	Natural, air cooling	
Voltage resistance	Between input/output--2.0kVA per minute (20mA) Between cabinets--2.0kVA per minute (20mA)	
Insulation resistance	Output - 100MΩ or more between cabinets at 500 VDC	
Circuit method	Separate excitation type flyback converter	
Weight	Aprox. 0.9kg	

Outer dimensions

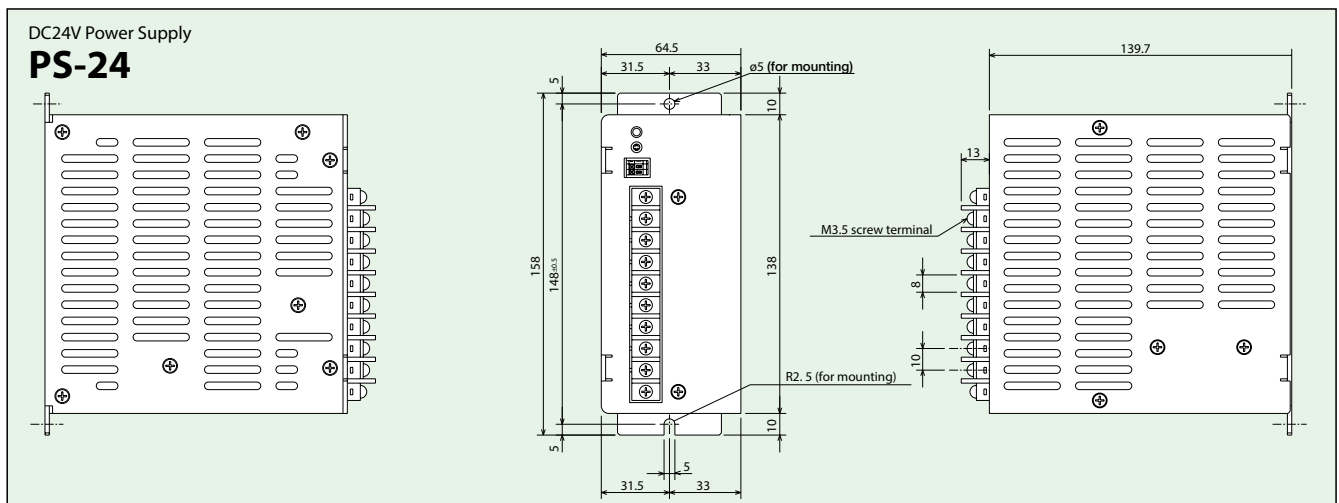

Caution:

- The PS-24 is not a constant voltage power supply. The output voltage changes with the load (voltage decreases according to the load percentage). Therefore, do not connect any equipment other than ROBO Cylinder actuators.
- Up to 5 units can be operated in parallel. Do not use any power supplies other than the PS-24 at the same time for parallel operation.
- Note that serial operations are not possible.
- As a rule, when operating multiple units in a row, allow at least 20mm space between each power supply.
- This is a natural air-cooled power supply. Please give due consideration to natural convection so that heat does not build up around the power supply.
- The case of this product also has heat a dissipating effect. Do not touch the case after installation as it may result in severe burns.