

# RCS2-RGD4C

ROBO Cylinder Rod Type with Double Guide ø37mm Diameter 200V Servo Motor Coupled

■ Configuration: **RCS2** — **RGD4C** —  —  —  —  —  —  —  —  —

Series — Type — Encoder — Motor — Lead — Stroke — Compatible Controllers — Cable Length — Option

I : Incremental  
A : Absolute

20 : 20W Servo Motor  
30 : 30W Servo Motor

12 : 12mm  
6 : 6mm  
3 : 3mm

50 : 50mm  
300 : 300mm (50mm pitch increments)

T1 : XSEL-J/K  
T2 : SCON  
SSEL  
XSEL-P/Q

N : None  
P : 1m  
S : 3m  
M : 5m  
X  : Custom  
R  : Robot cable

\* See page Pre-35 for an explanation of the naming convention.

**For High Acceleration/Deceleration** (\*1)

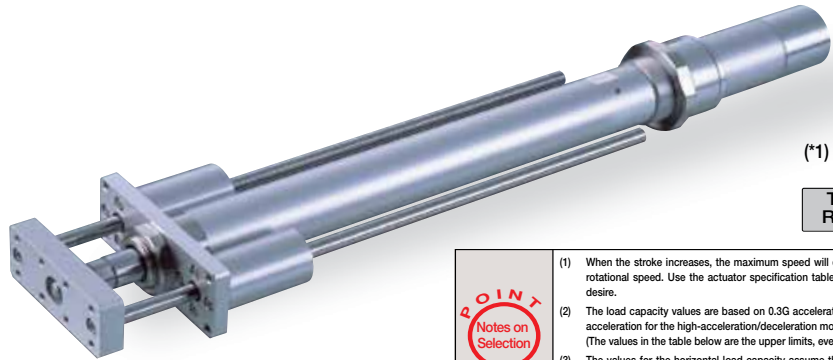

(\*1) Except all 20W models and 30W 3mm lead models

**Technical References** P. A-5



- (1) When the stroke increases, the maximum speed will drop to prevent the ball screw from reaching the critical rotational speed. Use the actuator specification table below to check the maximum speed at the stroke you desire.
- (2) The load capacity values are based on 0.3G acceleration for the standard model (0.2G for 3mm-lead), and 1G acceleration for the high-acceleration/deceleration model (3mm-lead excluded). (The values in the table below are the upper limits, even if the acceleration/deceleration is decreased.)
- (3) The values for the horizontal load capacity assume the use of an external guide, so that there is no external force from any direction other than the forward/backward direction of the rod. See the technical resources (page A-83) for the allowable weight using the supplied guide alone.

Actuator Specifications						
■ Lead and Load Capacity						
Model	Motor Output (W)	Lead (mm)	Max. Load Capacity		Rated Thrust (N)	Stroke (mm)
			Horizontal (kg)	Vertical (kg)		
RCS2-RGD4C-①-20-12-②-③-④-⑤	20	12	3.0	0.5	18.9	50 ~ 300 (50mm increments)
RCS2-RGD4C-①-20-6-②-③-④-⑤		6	6.0	1.5	37.7	
RCS2-RGD4C-①-20-3-②-③-④-⑤		3	12.0	3.5	75.4	
RCS2-RGD4C-①-30-12-②-③-④-⑤	30	12	4.0	1.0	28.3	
RCS2-RGD4C-①-30-6-②-③-④-⑤		6	9.0	2.5	56.6	
RCS2-RGD4C-①-30-3-②-③-④-⑤		3	18.0	6.0	113.1	

■ Stroke and Maximum Speed		
Lead	Stroke	50 ~ 300 (50mm increments)
	12	600
6	300	
3	150	

(Unit: mm/s)

Legend: ① Encoder ② Stroke ③ Compatible controller ④ Cable length ⑤ Options

Encoder & Stroke List				
② Stroke (mm)	Standard Price			
	① Encoder			
	Incremental		Absolute	
	Motor Output (W)		Motor Output (W)	
	20W	30W	20W	30W
50	-	-	-	-
100	-	-	-	-
150	-	-	-	-
200	-	-	-	-
250	-	-	-	-
300	-	-	-	-

④ Cable List		
Type	Cable Symbol	Standard Price
Standard	P (1m)	-
	S (3m)	-
	M (5m)	-
Special Lengths	X06 (6m) ~ X10 (10m)	-
	X11 (11m) ~ X15 (15m)	-
	X16 (16m) ~ X20 (20m)	-
	R01 (1m) ~ R03 (3m)	-
Robot Cable	R04 (4m) ~ R05 (5m)	-
	R06 (6m) ~ R10 (10m)	-
	R11 (11m) ~ R15 (15m)	-
	R16 (16m) ~ R20 (20m)	-

\* See page A-39 for cables for maintenance.

⑤ Option List			
Name	Option Code	See Page	Standard Price
Brake	B	→ A-25	-
Foot bracket	FT	→ A-29	-
High-acceleration/deceleration (*1)	HA	→ A-32	-
Home sensor (*2)	HS	→ A-32	-
Reversed-home	NM	→ A-33	-
Trunnion bracket (back)	TRR	→ A-38	-

Actuator Specifications	
Item	Description
Drive System	Ball screw ø10mm C10 grade
Positioning Repeatability	±0.02mm
Lost Motion	0.1mm or less
Guide	Double guide (guide rod diameter ø10, Ball bush type)
Rod Diameter	ø20mm
Non-rotating accuracy of rod	±0.05 deg
Ambient Operating Temp./Humidity	0 ~ 40°C, 85% RH or less (non-condensing)

(\*1) The high-acceleration/deceleration option is not available for all 20W models and 30W model with 3mm lead.  
(\*2) The home sensor (HS) cannot be used on the reversed-home models.

# 257

RCS2-RGD4C

Dimensions

For Special Orders P. A-9

- \*1. The motor-encoder cable is connected here. See page A-39 for details on cables.
  - \*2. When homing, the rod moves to the ME; therefore, please watch for any interference with the surrounding objects.
- ME: Mechanical end SE: Stroke end

[No Brake]

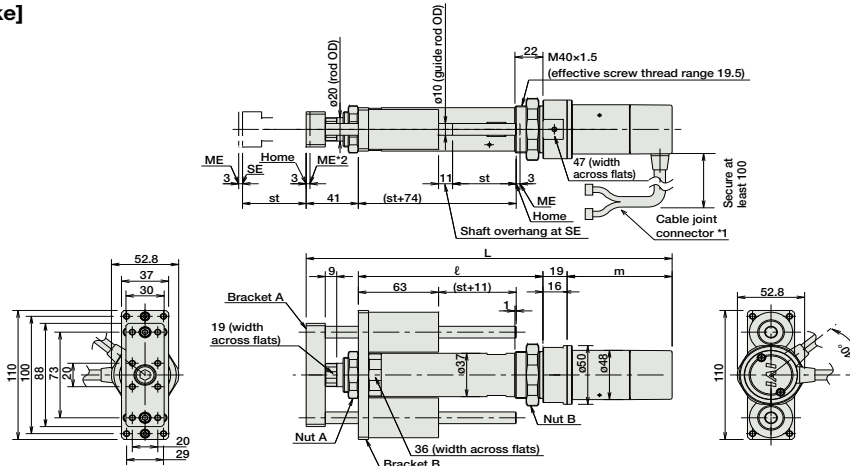

[Brake-Equipped]

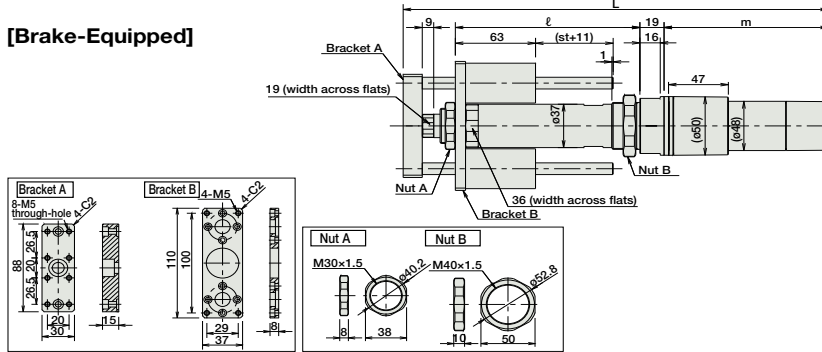

■ Dimensions/Weight by Stroke

RCS2-RGD4C (without brake)

Stroke	50	100	150	200	250	300
L	20W	285.5	335.5	385.5	435.5	535.5
	30W	300.5	350.5	400.5	450.5	550.5
ℓ	145	195	245	295	345	395
m	20W	80.5				
	30W	95.5				
Weight (kg)	1.8	2.0	2.2	2.4	2.6	2.8

RCS2-RGD4C (with brake)

Stroke	50	100	150	200	250	300
L	20W	328.5	378.5	428.5	478.5	578.5
	30W	343.5	393.5	443.5	493.5	593.5
ℓ	145	195	245	295	345	395
m	20W	123.5				
	30W	138.5				
Weight (kg)	2.0	2.2	2.4	2.6	2.8	3.0

③ Compatible Controllers

The RCS2 series actuators can operate with the controllers below. Select the controller according to your usage.

Name	External View	Model	Description	Max. Positioning Points	Input Voltage	Power Supply Capacity	Standard Price	See Page
Positioner Mode		SCON-C-20①-NP-2-③ SCON-C-30D①②-NP-2-③	Positioning is possible for up to 512 points	512 points	Single-Phase AC 100V Single-Phase AC 200V Three-phase AC 200V (XSEL-P/Q only)	360VA max.  * When operating a 150W single-axis model	-	→ P547
Solenoid Valve Mode			Operable with the same controls as the solenoid valve.	7 points				
Serial Communication Type			Dedicated to serial communication	64 points				
Pulse Train Input Control Type			Dedicated to Pulse Train Input	(-)				
Program Control 1-2 Axes Type		SSEL-C-1-20①-NP-2-③ SSEL-C-1-30D①②-NP-2-③	Programmed operation is possible Operation is possible on up to 2 axes	20000 points			-	→ P577
Program Control 1-6 Axes Type		XSEL-④-1-20①-N1-EEE-2-⑤ XSEL-④-1-30D①②-N1-EEE-2-⑤	Programmed operation is possible Operation is possible on up to 6 axes	20000 points			-	→ P587

\* For SSEL and XSEL, only applicable to the single-axis model.  
 \* ① is a placeholder for the encoder type (I: incremental / A: absolute).  
 \* ② is a placeholder for the code "HA" if the high-acceleration/deceleration option is specified.  
 \* ③ is a placeholder for the power supply voltage (1: 100V, 2: single-phase 200V).  
 \* ④ is a placeholder for the XSEL type name ("J", "K", "P", "Q").  
 \* ⑤ is a placeholder for the power supply voltage (1: 100V, 2: single-phase 200V, or 3: three-phase 200V).

- Slider Type
- Mini
- Standard
- Controllers Integrated
- Rod Type
- Mini
- Standard
- Controllers Integrated
- Table/Arm /Flat Type
- Mini
- Standard
- Gripper/ Rotary Type
- Linear Servo Type
- Cleanroom Type
- Splash Proof
- Controllers
- PMEC /AMEC
- PSEP /ASEP
- ROBO NET
- ERC2
- PCON
- ACON
- SCON
- PSEL
- ASEL
- SSEL
- XSEL
- Pulse Motor
- Servo Motor (24V)
- Servo Motor (200V)
- Linear Servo Motor