

RCS2CR-SA5C

Cleanroom ROBO Cylinder Slider Coupling Type 52mm Width 200V Servo Motor Aluminum Base

■ Configuration: **RCS2CR** — **SA5C** — — **20** — — — — —

Series — Type — Encoder — Motor — Lead — Stroke — Compatible Controllers — Cable Length — Option

I : Incremental A : Absolute 20 : 20W servo motor 12: 12mm 6: 6mm 3: 3mm 50: 50mm 500: 500mm (50mm pitch increments) T1:XSEL-J/K T2:SCON SSEL XSEL-P/Q N : None P : 1m S : 3m M : 5m X : Custom R : Robot cable See Options below

* See page Pre-35 for an explanation of the naming convention.



Technical References P. A-5

- POINT** Notes on Selection
- (1) When the stroke increases, the maximum speed will drop to prevent the ball screw from reaching the critical rotational speed. Use the actuator specification table below to check the maximum speed at the stroke you desire.
 - (2) The load capacity is based on operation at an acceleration of 0.3G (0.2G for the 3mm-lead model). This is the upper limit of the acceleration.

Actuator Specifications										
Lead and Load Capacity			Stroke, Max. Speed/Suction Volume							
Model	Motor Output (W)	Lead (mm)	Max. Load Capacity	Rated Thrust (N)	Stroke (mm)	Stroke / Lead	50~450 (50mm increments)	500 (mm)	Suction Volume (Nl/min)	
RCS2CR-SA5C-①-20-12-②-③-④-⑤	20	12	4	1	16.7	50~500 (50mm increments)	12	800	760	50
RCS2CR-SA5C-①-20-6-②-③-④-⑤		6	8	2	33.3		6	400	380	30
RCS2CR-SA5C-①-20-3-②-③-④-⑤		3	12	4	65.7		3	200	190	15

Legend: ① Encoder ② Stroke ③ Compatible controller ④ Cable length ⑤ Options (Unit: mm/s)

① Encoder & Stroke List		
Stroke (mm)	Standard Price	
	Encoder Type	
	Incremental	Absolute
50	-	-
100	-	-
150	-	-
200	-	-
250	-	-
300	-	-
350	-	-
400	-	-
450	-	-
500	-	-

④ Cable List		
Type	Cable Symbol	Standard Price
Standard Type	P (1m)	-
	S (3m)	-
	M (5m)	-
Special Lengths	X06 (6m) ~ X10 (10m)	-
	X11 (11m) ~ X15 (15m)	-
	X16 (16m) ~ X20 (20m)	-
Robot Cable	R01 (1m) ~ R03 (3m)	-
	R04 (4m) ~ R05 (5m)	-
	R06 (6m) ~ R10 (10m)	-
	R11 (11m) ~ R15 (15m)	-
	R16 (16m) ~ R20 (20m)	-

* See page A-39 for cables for maintenance.

⑤ Option List			
Name	Option Code	See Page	Standard Price
Brake	B	→ A-25	-
Foot bracket	FT	→ A-29	-
Home sensor	HS	→ A-32	-
Reversed-home	NM	→ A-33	-
Intake port mounted on opposite side	VR	→ A-38	-

Actuator Specifications	
Item	Description
Drive System	Ball screw ϕ 10mm C10 grade
Positioning Repeatability	\pm 0.02mm
Lost Motion	0.1mm or less
Base	Material: Aluminum (white alumite treated)
Allowable Static Moment	Ma: 18.6N·m Mb: 26.6N·m Mc: 47.5N·m
Allowable Dynamic Moment (*)	Ma: 4.9N·m Mb: 6.8N·m Mc: 11.7N·m
Overhang Length	Ma direction: 150mm or less; Mb, Mc direction: 150mm or less
Grease type	Low dust generation grease (both ball screw and guide)
Cleanliness	Class 10 (0.1 μ m)
Ambient Operating Temp./Humidity	0~40°C, 85% RH or less (non-condensing)



427 RCS2CR-SA5C

Dimensions

For Special Orders P. A-9

- *1 The motor-encoder cable is connected here. See page A-39 for details on cables.
- *2 After homing, the slider moves to the ME; therefore, please watch for any interference with the surrounding objects.
ME: Mechanical end SE: Stroke end
- *3 Reference position for calculating the moment Ma.
- *4 If the actuator is secured using only the mounting holes provided on the top surface of the base, the base may twist to cause abnormal sliding of the slider, or may produce abnormal noise. Therefore, when using the mounting holes on the top surface of the base, keep the stroke at 300mm or less.

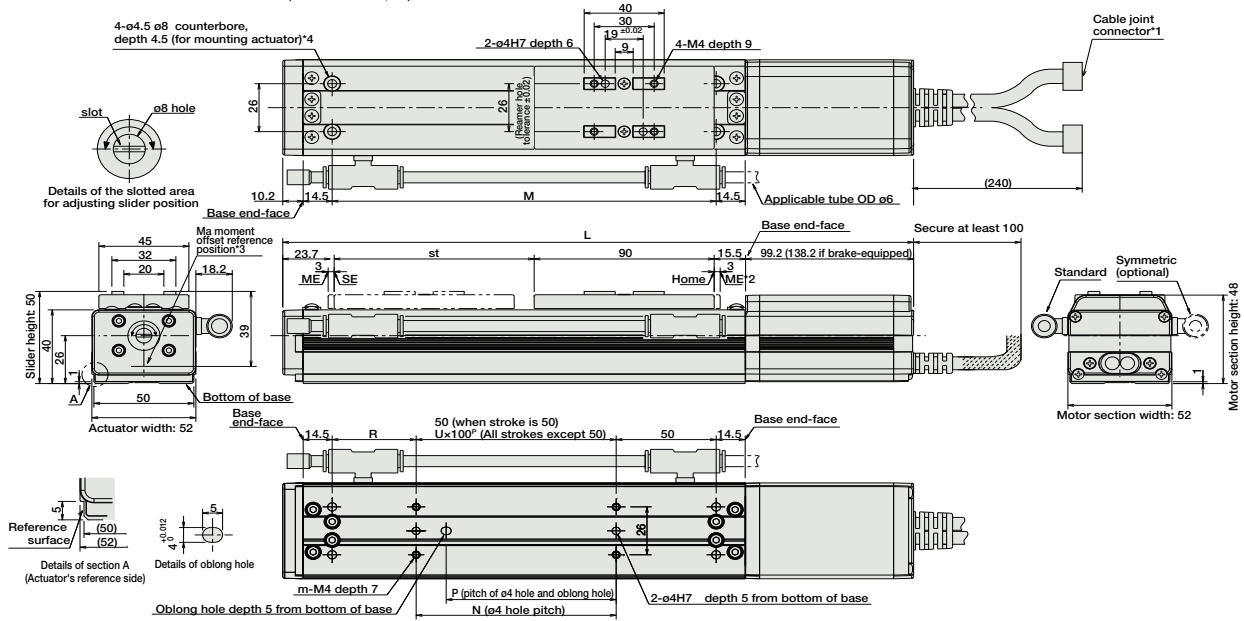

■ Dimensions and Weight by Stroke * Adding a brake will increase the actuator's weight by 0.3kg.

Stroke	50	100	150	200	250	300	350	400	450	500	
L	No Brake	280.4	330.4	380.4	430.4	480.4	530.4	580.4	630.4	680.4	730.4
	With Brake	319.4	369.4	419.4	469.4	519.4	569.4	619.4	669.4	719.4	769.4
M	142	192	242	292	342	392	442	492	542	592	
N	50	100	100	200	200	300	300	400	400	500	
P	35	85	85	185	185	285	285	385	385	485	
R	42	42	92	42	92	42	92	42	92	42	
U	-	1	1	2	2	3	3	4	4	5	
m	4	4	4	6	6	8	8	10	10	12	
Weight (kg)	1.3	1.4	1.5	1.6	1.7	1.8	1.9	2	2.1	2.2	

③ Compatible Controllers

The RCS2CR series actuators can operate with the controllers below. Select the controller according to your usage.

Name	External View	Model	Description	Max. Positioning Points	Input Voltage	Power Supply Capacity	Standard Price	See Page
Positioner Mode		SCON-C-20①-NP-2-②	Positioning is possible for up to 512 points	512 points	Single-phase AC100V Single-phase AC200V Three-phase AC200V (XSEL-P/Q only)	360VA max. * When operating a 150W single-axis model	-	→ P547
Solenoid Valve Mode			Operable with the same controls as the solenoid valve	7 points				
Serial Communication Type			Dedicated to serial communication	64 points				
Pulse Train Input Control Type			Dedicated to pulse train input	(-)				
Program Control 1-2 Axes Type		SSEL-C-1-20①-NP-2-②	Programmed operation is possible Operation is possible on up to 2 axes	20000 points			-	→ P577
Program Control 1-6 Axes Type		XSEL-③-1-20①-N1-EEE-2-④	Programmed operation is possible Operation is possible on up to 6 axes	20000 points			-	→ P587

* For SSEL and XSEL, only applicable to the single-axis model.
 * ① is a placeholder for the encoder type (I: incremental / A: absolute).
 * ② is a placeholder for the power supply voltage (1: 100V, or 2: single-phase 200V).
 * ③ is a placeholder for the XSEL type name ("J", "K", "P", or "Q").
 * ④ is a placeholder for the power supply voltage (1: 100V, 2: single-phase 200V, 3: 3-phase 200V).

- Slider Type
- Mini
- Standard
- Controllers Integrated
- Rod Type
- Mini
- Standard
- Controllers Integrated
- Table/Arm /Flat Type
- Mini
- Standard
- Gripper/ Rotary Type
- Linear Servo Type
- Cleanroom Type
- Splash-Proof
- Controllers
- PMEC /AMEC
- PSEP /ASEP
- ROBO NET
- ERC2
- PCON
- ACON
- SCON
- PSEL
- ASEL
- SSEL
- XSEL
- Pulse Motor
- Servo Motor (24V)
- Servo Motor (200V)
- Linear Servo Motor