

IAI

Quality and Innovation

Rotary-Type ROBO Cylinder

RCP2-RT



Sold & Serviced By:

 **ELECTROMATE**

Toll Free Phone (877) SERV098

Toll Free Fax (877) SERV099

www.electromate.com

sales@electromate.com

More Selection, More Benefits

6 Rotary Actuators to Meet Your Needs



1 Choose from 6 types

Now customers can choose from a total of 6 types: slim vertical types and lower horizontal types, each available in small, medium, and large sizes.

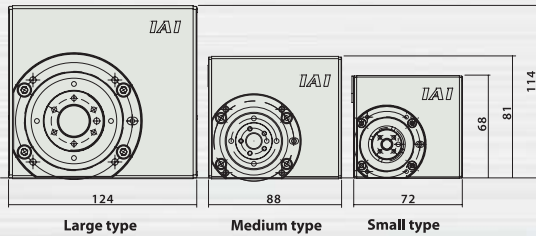

4 High-precision positioning

You'll achieve new heights in automation with repeatability of ± 0.01 degrees.* Great for applications requiring high precision.

(*2) The repeatability of the small model is ± 0.05 degrees.

2 Hollow structure

The output axis of the horizontal type has a hollow structure, so wires from devices installed along the output axis can be passed through it.



5 Can use up to 1500 positions

If a PSEL controller is used, up to 1500 positions can be used. (*3)

Customers can choose from the following controller types: positioner, serial communication, pulse line, electromagnetic valve, and program types.

(*3) Please note that the maximum number of positions varies depending on the controller

3 Multiple rotation specifications

All models have multiple rotation specifications that allow rotations exceeding 360 degrees. They can be operated in the same rotational direction, like a conveyor (*1).

(*1) One rotation is within ± 360 degrees.

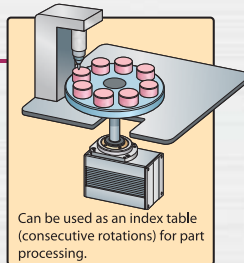

Can be used as an index table (consecutive rotations) for part processing.



1

Type	Small				Medium				Large					
Shape	Vertical		Horizontal		Vertical		Horizontal		Vertical		Horizontal			
Type	RTBS (standard specifications) RTBSL (multiple rotation specifications)		RTCS (standard specifications) RTCSL (multiple rotation specifications)		RTB (standard specifications) RTBL (multiple rotation specifications)		RTC (standard specifications) RTCL (multiple rotation specifications)		RTBB (standard specifications) RTBBL (multiple rotation specifications)		RTCB (standard specifications) RTCBL (multiple rotation specifications)			
Speed reduction ratio	1/30	1/45	1/30	1/45	1/20	1/30	1/20	1/30	1/20	1/30	1/20	1/30		
Operating range	Degrees Standard specifications: 330 degrees. Multiple rotation specifications: ±9999 degrees (*1)													
Reverse rotation specifications	Standard specifications: none. Multiple rotation specifications: yes													
Max. torque (*2)	N • m		0.24	0.36	0.24	0.36	1.1	1.7	1.1	1.7	3	4.6	3	4.6
Max. operating speed (*3)	Degrees/sec		400	266	400	266	600	400	600	400	600	400	600	400
Repeat stop precision (*4)	Degrees		±0.05				±0.01				±0.01			
Backlash	Degrees		±0.1				±0.1				±0.1			
Allowable thrust load (*5)	N		30				50				200			
Allowable load moment (*5)	N • m		3.6				3.9				17.7			
Detection method	Electromagnetic encoder (incremental)													
Origin point detection method	Standard specifications: mechanical stopper method. Multiple rotation specifications: proximity sensor method													
Precision to restore to the original point	Degrees		Standard specifications: Within ±0.05 Multiple rotation specifications: Within ±0.05				Standard specifications: Within ±0.01 Multiple rotation specifications: Within ±0.05				Standard specifications: Within ±0.01 Multiple rotation specifications: Within ±0.03			
Usage environment	Temperature: 0-40°C, Humidity: 20-85% RH or less (no condensation)													
Outer dimensions of main unit (thickness x width x height)	mm		45×72×70		68×72×45		50×88×83.5		81×88×55		76×124×107		114×124×68	
Mass of main unit	kg		0.52		0.48		0.86		0.92		2.3		2.2	
Motor cable type	CB-PCS-MPA□□□□				CB-RCP2-MA□□□□ *The standard motor cable is a robot cable.									
Encoder cable type	(Cable with motor and encoder in one)				CB-RCP2-PB□□□□ (CB-RCP2-PB-RB) (*1)									

- (*1) Multiple rotation specifications: in normal mode, it is possible to move up to ± 9999 degrees of consecutive travel.
- (*2) Maximum torque changes depending on the speed. (See the front and back sides of the model selection document)
- (*3) The maximum speed changes depending on the load.
- (*4) Shows the repeat positioning precision from one direction.
- (*5) If loads exceeding these values are used, it may cause damage or shorten the lifespan of the unit. (See the diagram on the right for the direction of force)
- (*6) Robot cable types are inside ().

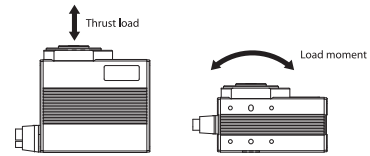

Model Number

RCP2 — — **I** — — — — — — **P1** — —

Series — Type — Encoder type — Motor type — Speed reduction ratio — Vibration angle — Applicable controller — Cable length — Options

RTBS : Small vertical standard I: Incremental
 RTBSL : Small vertical multiple rotation
 RTCS : Small horizontal standard
 RTCSL : Small horizontal multiple rotation
 RTB : Medium vertical standard
 RTBL : Medium vertical multiple rotation
 RTC : Medium horizontal standard
 RTCL : Medium horizontal multiple rotation
 RTBB : Large vertical standard
 RTBBL : Large vertical multiple rotation
 RTCB : Large horizontal standard
 RTCBL : Large horizontal multiple rotation

20P: Pulse motor 20: Speed reduction ratio 330: 330 degrees
 20 size 1/20 360: 360 degrees
 28P: Pulse motor 30: Speed reduction ratio (Multiple rotation)
 28 size 1/30
 35P: Pulse motor 45: Speed reduction ratio
 35 size 1/45

P1: PCON
 PSEL

N: None
 P: 1 m
 S: 3 m
 M: 5 m
 X □ □: Length designation
 R □ □: Robot cable
 * Robot cables are standard for small types.

Type			Type	Model
Small	Vertical	Standard specifications	RCP2-RTBS-I-20P-30(45)-330-P1	
		Multiple rotation specification	RCP2-RTBSL-I-20P-30(45)-360-P1	
	Horizontal	Standard specifications	RCP2-RTCS-I-20P-30(45)-330-P1	
		Multiple rotation specification	RCP2-RTCSL-I-20P-30(45)-360-P1	
Medium	Vertical	Standard specifications	RCP2-RTB-I-28P-20(30)-330-P1	
		Multiple rotation specification	RCP2-RTBL-I-28P-20(30)-360-P1	
	Horizontal	Standard specifications	RCP2-RTC-I-28P-20(30)-330-P1	
		Multiple rotation specification	RCP2-RTCL-I-28P-20(30)-360-P1	
Large	Vertical	Standard specifications	RCP2-RTBB-I-35P-20(30)-330-P1	
		Multiple rotation specification	RCP2-RTBBL-I-35P-20(30)-360-P1	
	Horizontal	Standard specifications	RCP2-RTCB-I-35P-20(30)-330-P1	
		Multiple rotation specification	RCP2-RTCBL-I-35P-20(30)-360-P1	

Cable Length		Type	Cable Code
Standard type		P (1m)	
		S (3m)	
		M (5m)	
Special lengths		X06 (6m) - X10 (10m)	
		X11 (11m) - X15 (15m)	
		X16 (16m) - X20 (20m)	
		R01 (1m) - R03 (3m)	
Robot cable		R04 (4m) - R05 (5m)	
		R06 (6m) - R10 (10m)	
		R11 (11m) - R15 (15m)	
		R16 (16m) - R20 (20m)	

Options		Name	Option Symbol
	Reverse rotation specifications		NM
	Shaft adapter		SA
	Table adapter		TA

*Option pricing is the same for small, medium, and large types.

Applicable Controller		Name	Type
	Positioner type	PCON-C-□I-NP-2-0	
	Safety category compatible type	PCON-CG-□I-NP-2-0	
	Electromagnetic valve type	PCON-CY-□I-NP-2-0	
	Pulse line type (differential)	PCON-PL-□I-NP-2-0	
	Pulse line type (open collector)	PCON-PO-□I-NP-2-0	
	Serial type	PCON-SE-□I-N-0-0	
	Field network type	RPCON-□	
	Program control type	PSEL-C-1-□I-NP-2-0	

* The □ in the above model designations denote numbers representing the motor of the main rotary unit.
 Example: When operating a large type: PCON-C-35PI-NP-2-0



Small vertical type

Note:
* The diagonal lines on the right top view show the rotating areas.

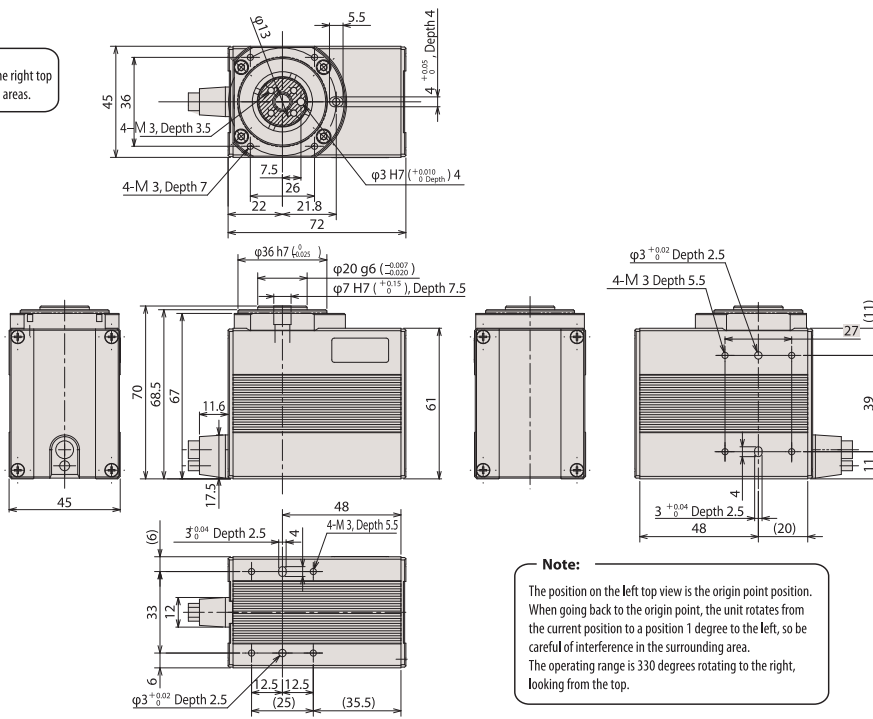

Note:
The position on the left top view is the origin point position. When going back to the origin point, the unit rotates from the current position to a position 1 degree to the left, so be careful of interference in the surrounding area. The operating range is 330 degrees rotating to the right, looking from the top.

Mass (kg)	0.52
-----------	------

Small horizontal type



Note:
The diagonal lines on the right top view show the rotating areas.

CAD drawing can be downloaded from the website. www.intelligentactuator.com

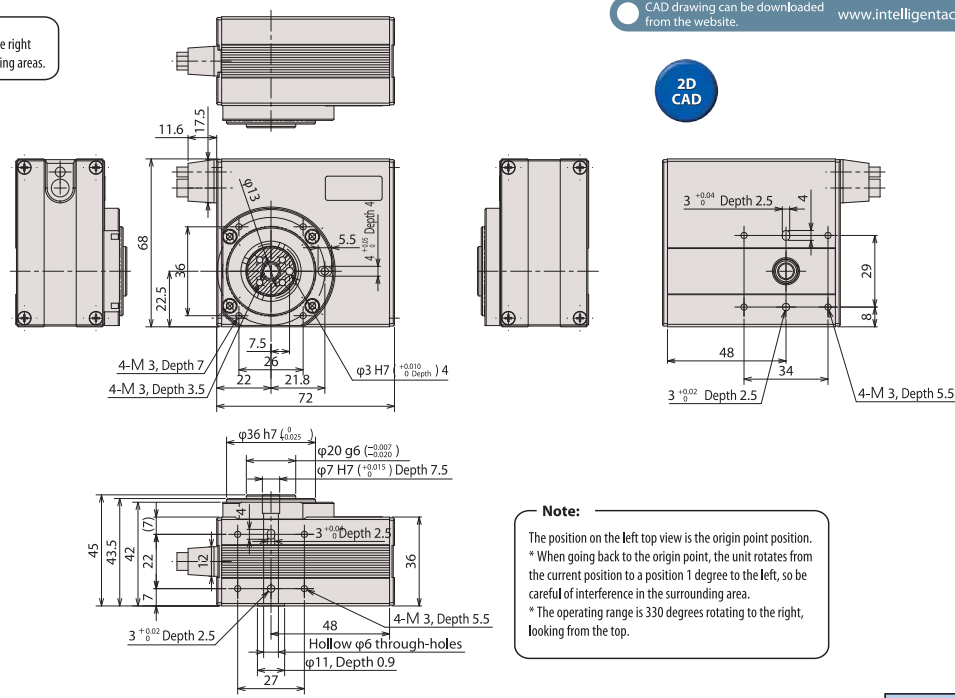

Note:
The position on the left top view is the origin point position. * When going back to the origin point, the unit rotates from the current position to a position 1 degree to the left, so be careful of interference in the surrounding area. * The operating range is 330 degrees rotating to the right, looking from the top.

Mass (kg)	0.48
-----------	------

Medium vertical type



Note:
* The diagonal lines on the right top view show the rotating areas.

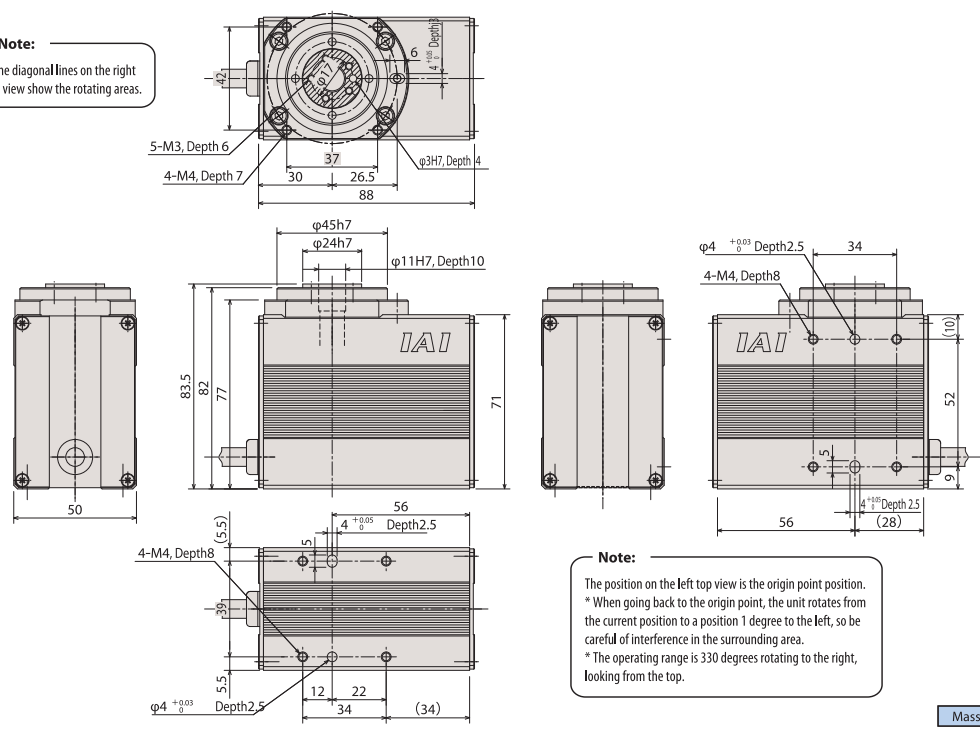

Note:
The position on the left top view is the origin point position.
* When going back to the origin point, the unit rotates from the current position to a position 1 degree to the left, so be careful of interference in the surrounding area.
* The operating range is 330 degrees rotating to the right, looking from the top.

Mass (kg)	0.86
-----------	------

Medium horizontal type



Note:
The diagonal lines on the right top view show the rotating areas.

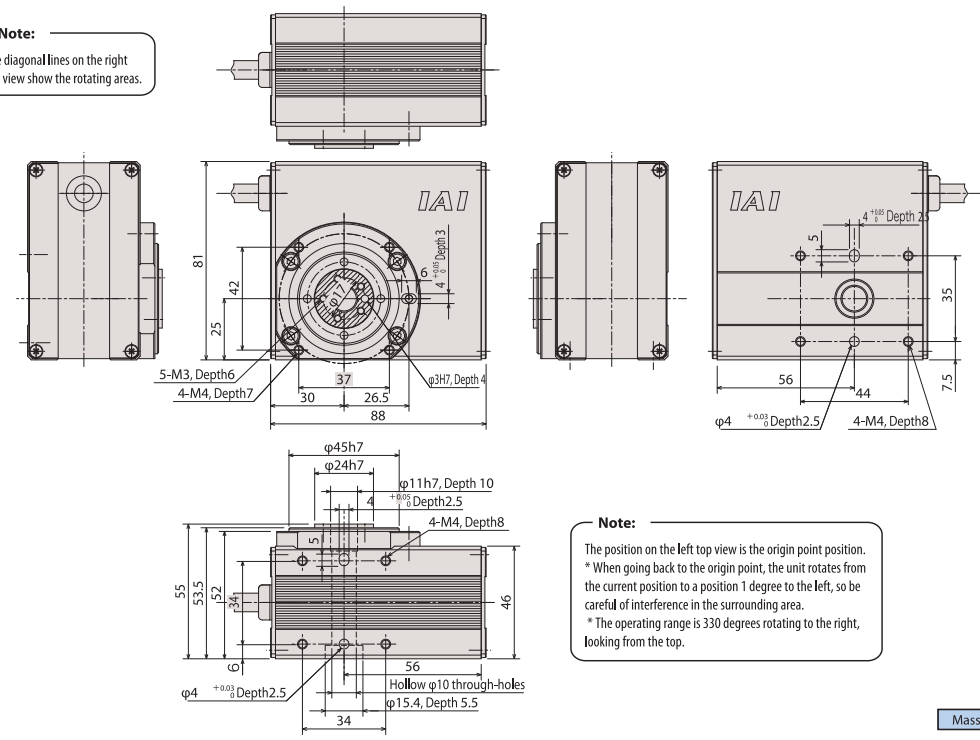

Note:
The position on the left top view is the origin point position.
* When going back to the origin point, the unit rotates from the current position to a position 1 degree to the left, so be careful of interference in the surrounding area.
* The operating range is 330 degrees rotating to the right, looking from the top.

Mass (kg)	0.92
-----------	------

Large vertical type



Note:
* The diagonal lines on the right top view show the rotating areas.

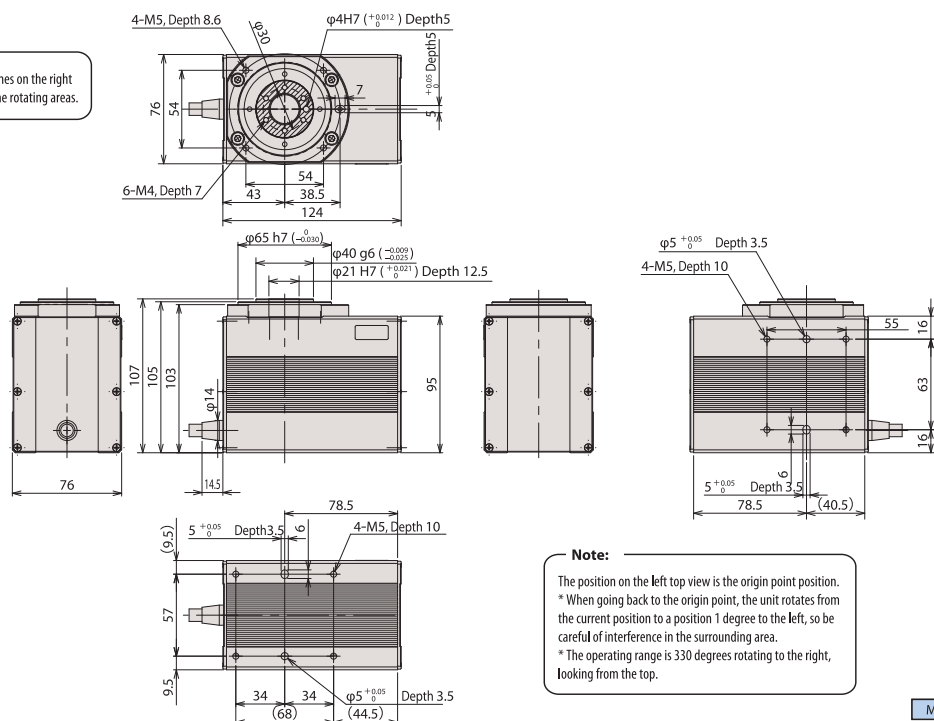

Note:
The position on the left top view is the origin point position.
* When going back to the origin point, the unit rotates from the current position to a position 1 degree to the left, so be careful of interference in the surrounding area.
* The operating range is 330 degrees rotating to the right, looking from the top.

Mass (kg)	2.3
-----------	-----

Large horizontal type

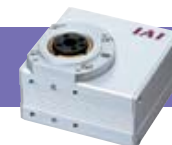

Note:
* The diagonal lines on the right top view show the rotating areas.

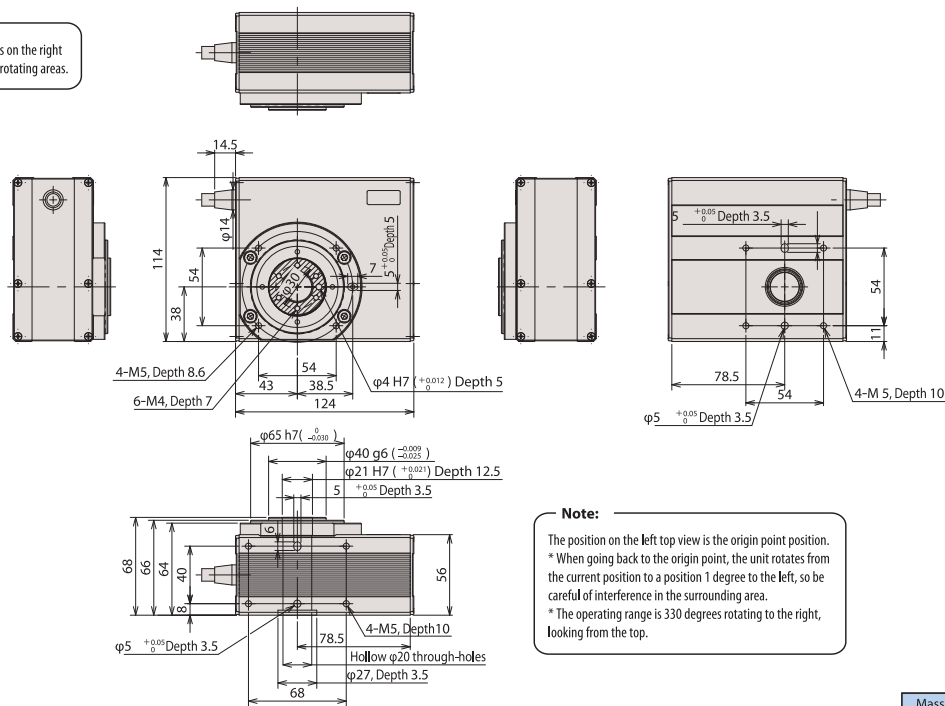

Note:
The position on the left top view is the origin point position.
* When going back to the origin point, the unit rotates from the current position to a position 1 degree to the left, so be careful of interference in the surrounding area.
* The operating range is 330 degrees rotating to the right, looking from the top.

Mass (kg)	2.2
-----------	-----

5

Shaft adapter

Model SA

This is a shaft-shaped adapter for attaching jigs, etc. to the rotating areas of the rotary type unit.

RCP2-RTBS/RTBSL Combination Drawing

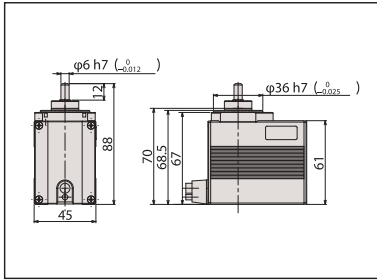

RCP2-RTB/RTBL Combination Drawing

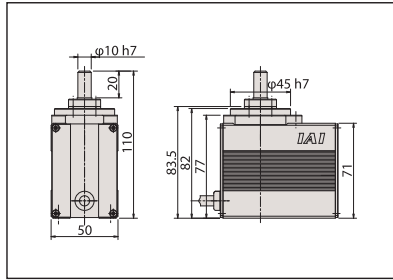

RCP2-RTBB/RTBBL Combination Drawing

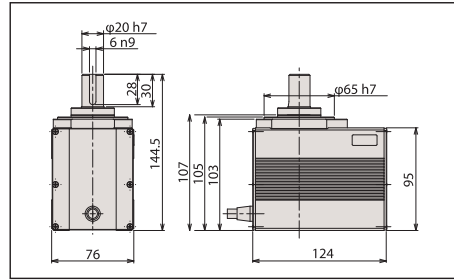

RCP2-RTCS/RTCSL Combination Drawing

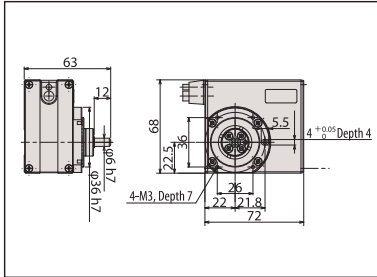

RCP2-RTC/RTCL Combination Drawing

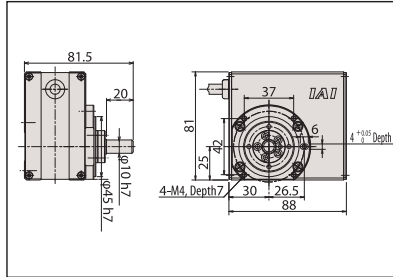

RCP2-RTCB/RTCBL Combination Drawing

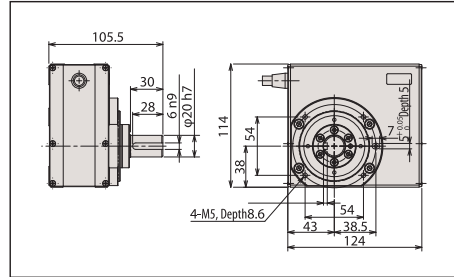
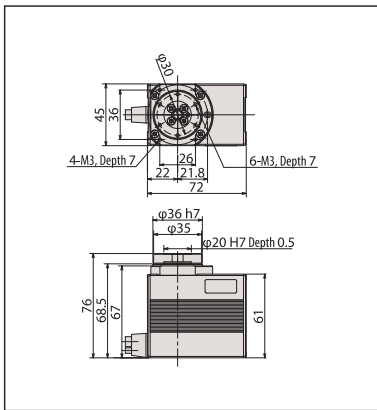

Table adapter

Model TA

This is a table-shaped adapter for attaching jigs, etc. to the rotating areas of the rotary-type unit.

RCP2-RTBS/RTBSL Combination Drawing



RCP2-RTB/RTBL Combination Drawing

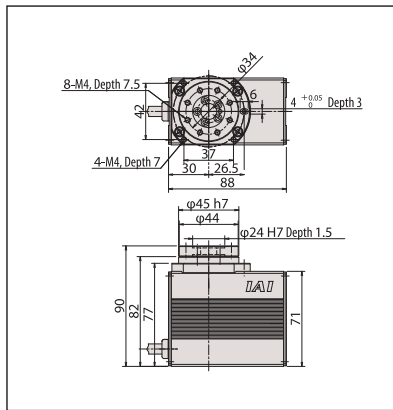

RCP2-RTBB/RTBBL Combination Drawing

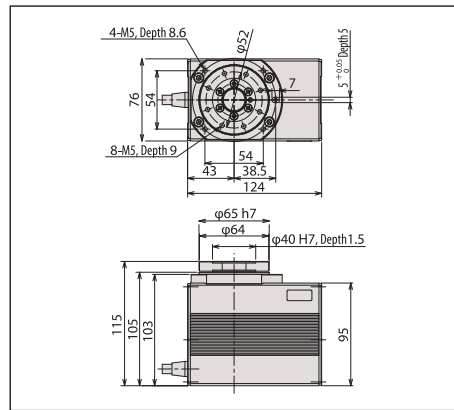

RCP2-RTCS/RTCSL Combination Drawing

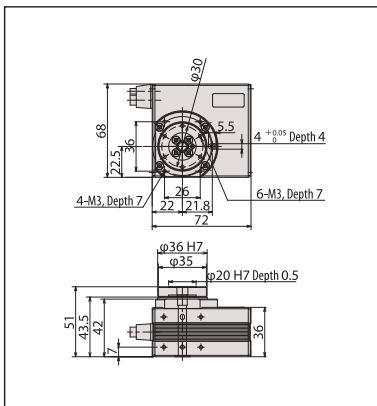

RCP2-RTC/RTCL Combination Drawing

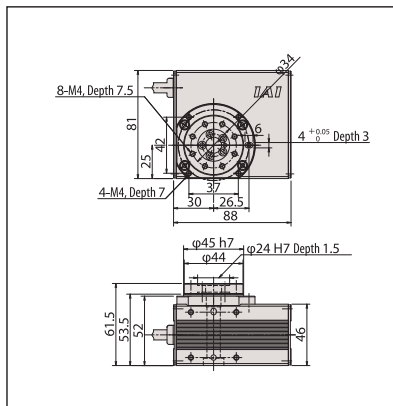

RCP2-RTCB/RTCBL Combination Drawing

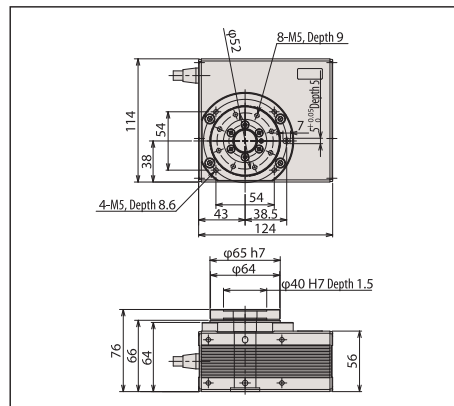

Selection goals

Output torque

Output torque decreases as rotational speed increases.

* Please use the bottom graph to verify whether you can get enough necessary speed torque for operation.

Small vertical type RTBS/RTBSL Small horizontal type RTCS/RTCSL

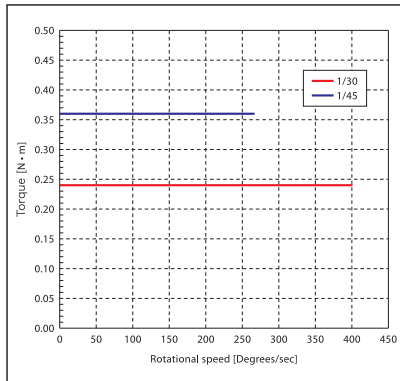

Medium vertical type RTB/RTBL Medium horizontal type RTC/RTCL

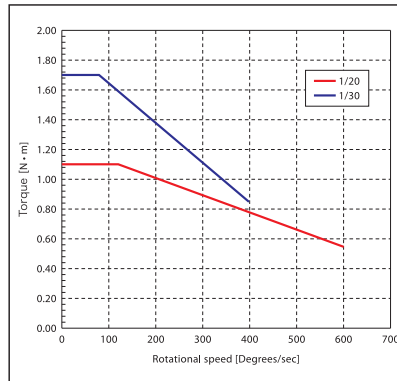

Large vertical type RTBB/RTBBL Large horizontal type RTCB/RTCBL

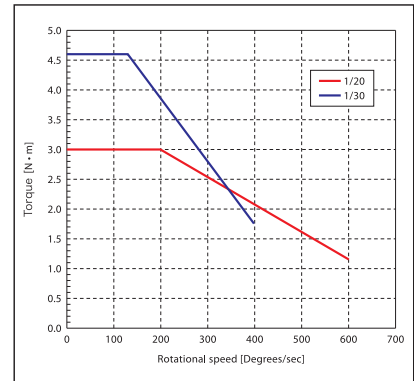

Allowable inertial moment

The allowable inertial moment for workpieces that can be rotated differs based on the rotational speed.

* Please verify the operating conditions and inertial moment of workpieces that can be rotated.

Small vertical type RTBS/RTBSL Small horizontal type RTCS/RTCSL

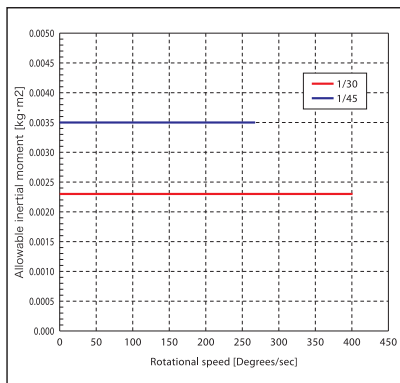

Medium vertical type RTB/RTBL Medium horizontal type RTC/RTCL

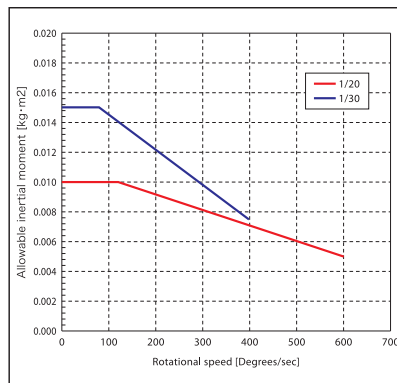

Large vertical type RTBB/RTBBL Large horizontal type RTCB/RTCBL

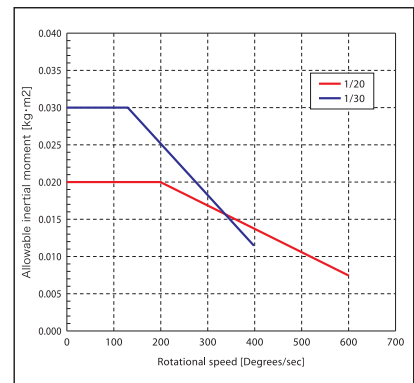

Inertial moment

Inertial moment expresses the amount of inertia in the rotational motion, and is equivalent to the mass for linear motion.

The larger the inertial moment, the more difficult it is for that object to move and stop.

That is, when choosing a rotary-type unit, whether or not the inertial moment (of the object that can be rotated) can be controlled or not is a decision-making factor.

* This type can be used if the inertial moment found in the calculation is smaller than the allowable inertial moment of the rotary type.

Calculation method for inertial moment for main shapes

J: Inertial moment (kg · m²)/M: Mass (kg)/r: Radius (m)/a.

- (1) **Cylinder (includes thin disc)**
Position of axis of rotation: center axis

$$J = M \cdot \frac{r^2}{2}$$

- (3) **Thin rectangular plate (rectangular solid)**
Position of axis of rotation: Pass one end perpendicular to the plate.

M1: Mass (kg) on a1 side
M2: Mass (kg) on a2 side

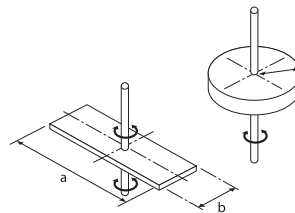
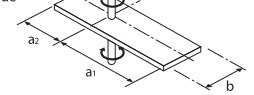

- (2) **Thin rectangular plate (rectangular solid)**
Position of axis of rotation: Pass one end perpendicular to the plate.
(Same, if using a rectangular solid with a thick plate)

$$J = M \cdot \frac{a^2 + b^2}{12}$$

$$J = M_1 \cdot \frac{4a_1^2 + b^2}{12} + M_2 \cdot \frac{4a_2^2 + b^2}{12}$$