

RCP2-RTCB/RTCBL

ROBO Cylinder Rotary Large Flat Type 124mm Width Pulse Motor

■ Configuration: **RCP2** — — **I** — **35P** — — — — —

Series — Type — Encoder — Motor — Deceleration Ratio — Oscillation Angle — Compatible Controllers — Cable Length — Option

RTCB : 330-degree rotation
 RTCBL : Multi-rotational

I: Incremental absolute encoder is also considered type "I".
 * The Simple absolute encoder is also considered type "I".

35P : 35 □ size Pulse motor
 20: 1/20 deceleration ratio
 30: 1/30 deceleration ratio
 330: 330degrees (RTB only)
 360: 360degrees (RTBL only)

P1: PCON
 RPCON
 PSEL
 P3: PMEC
 PSEP

N : None
 P : 4m
 S : 3m
 M : 5m
 X □ : Custom
 R □ : Robot cable

NM : Reversed-rotation
 SA : Shaft adapter
 TA : Table adapter

* See page Pre-35 for an explanation of the naming convention.



Technical References P. A-5



- (1) The output torque decreases as the rotational speed increases. Check the output torque graph on the right to see whether the speed required for your desired motion is supported.
- (2) The allowable moment of inertia of the rotated work piece varies with the rotational speed. Check the Allowable Moment of Inertia graph on the right to see if the moment of inertia required for your desired motion is within the allowable range.
- (3) The rated acceleration while moving is 0.3G.

■ Speed vs. Load Capacity
 Due to the characteristics of the Pulse motor, the RCP2 series' load capacity decreases at high speeds. In the table below, check if your desired speed and load capacity are supported.

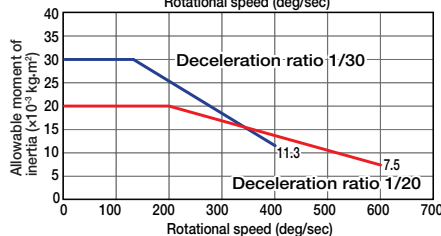
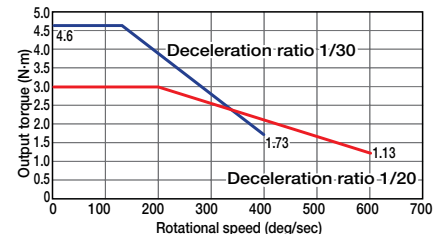

Actuator Specifications

Lead and Load Capacity

Model	Deceleration Ratio	Max. Torque (N·m)	Allowable Moment of Inertia (kg·m ²)	Oscillation Angle (deg)
RCP2-RTCB-I-35P-20-330-①-②-③	1/20	3.0	0.02	330
RCP2-RTCB-I-35P-30-330-①-②-③	1/30	4.6	0.03	330
RCP2-RTCBL-I-35P-20-360-①-②-③	1/20	3.0	0.02	360
RCP2-RTCBL-I-35P-30-360-①-②-③	1/30	4.6	0.03	360

Legend: ① Compatible controller ② Cable length ③ Options

Deceleration Ratio and Max. Speed

Stroke (Deceleration Ratio)	330/360 (deg)	
	1/20	600
1/30	400	

(Unit: degrees/s)

Stroke List

Type	Oscillation Angle (deg)	Standard Price
RTCB	330	-
RTCBL	360	-

② Cable List

Type	Cable Symbol	Standard Price
Standard Type	P (1m)	-
	S (3m)	-
	M (5m)	-
Special Lengths	X06 (6m) ~ X10 (10m)	-
	X11 (11m) ~ X15 (15m)	-
	X16 (16m) ~ X20 (20m)	-
Robot Cable	R01 (1m) ~ R03 (3m)	-
	R04 (4m) ~ R05 (5m)	-
	R06 (6m) ~ R10 (10m)	-
	R11 (11m) ~ R15 (15m)	-
	R16 (16m) ~ R20 (20m)	-
	R20 (20m)	-

* See page A-39 for cables for maintenance.

③ Option List

Name	Option Code	See Page	Standard Price
Reversed-rotation (*)	NM	→ A-33	-
Shaft adapter	SA	→ A-35	-
Table adapter	TA	→ A-37	-

* Reversed-rotation option can be selected on the multi-rotational model only.

Actuator Specifications

Item	Description
Drive System	Hypoid gear
Positioning Repeatability	±0.01 degrees
Homing Accuracy	±0.01 degrees
Lost Motion	±0.1 degrees
Allowable Thrust Load	200N
Allowable Load Moment	17.7N·m
Weight	2.2kg
Ambient Operating Temp./Humidity	0 ~ 40°C, 85% RH or less (non-condensing)

363

RCP2-RTCB/RTCBL

For Special Orders P. A-9

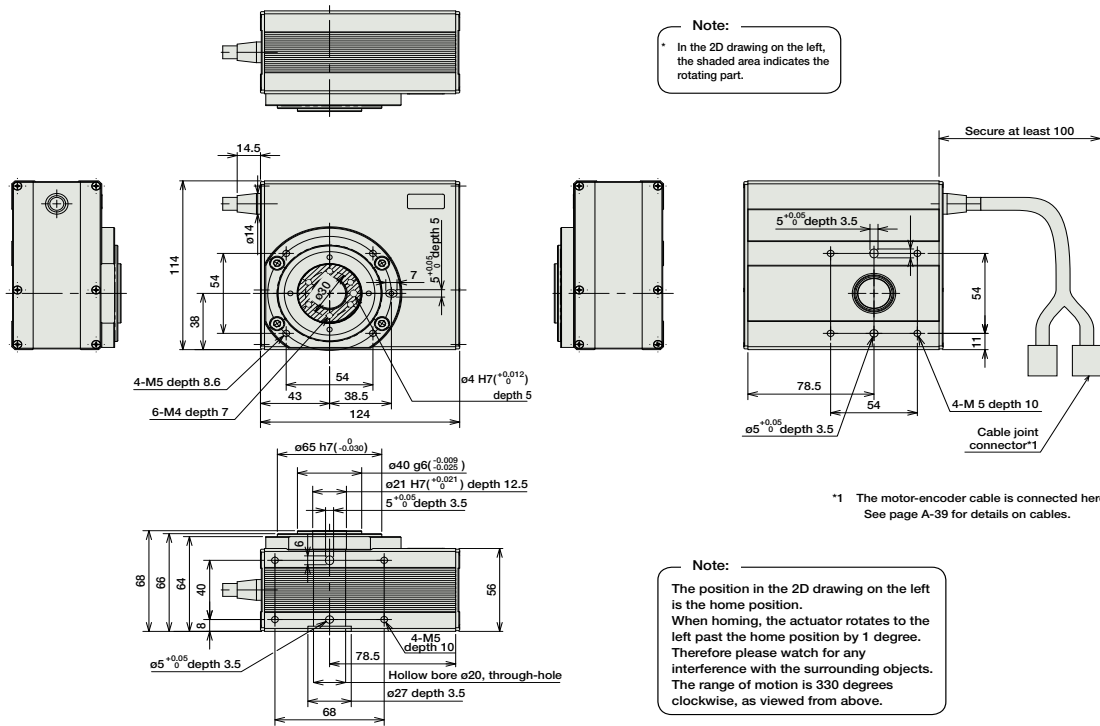

Weight (kg) 2.2

① Compatible Controllers

The RCP2 series actuators can operate with the controllers below. Select the controller according to your usage.

Name	External View	Model	Description	Max. Positioning Points	Input Voltage	Power Supply Capacity	Standard Price	See Page
Solenoid Valve Type		PMEC-C-35PI-NP-2-①	Easy-to-use controller, even for beginners	3 points	AC100V AC200V	See P481	-	→ P477
		PSEP-C-35PI-NP-2-0	Operable with same signal as solenoid valve. Supports both single and double solenoid types. No homing necessary with simple absolute type.				-	→ P487
Splash-Proof Solenoid Valve Type		PSEP-CW-35PI-NP-2-0					-	
Positioner Type		PCON-C-35PI-NP-2-0	Positioning is possible for up to 512 points	512 points	DC24V	2A max.	-	→ P525
Safety-Compliant Positioner Type		PCON-CG-35PI-NP-2-0					-	
Pulse Train Input Type (Differential Line Driver)		PCON-PL-35PI-NP-2-0	Pulse train input type with differential line driver support	(-)	DC24V	2A max.	-	→ P525
Pulse Train Input Type (Open Collector)		PCON-PO-35PI-NP-2-0	Pulse train input type with open collector support				-	
Serial Communication Type		PCON-SE-35PI-N-0-0	Dedicated to serial communication	64 points			-	
Field Network Type		RPCON-35P	Dedicated to field network	768 points			-	→ P503
Program Control Type		PSEL-C-1-35PI-NP-2-0	Programmed operation is possible Operation is possible on up to 2 axes	1500 points			-	→ P557

* This is for the single-axis PSEL.
 * ① is a placeholder for the power supply voltage (1: 100V, 2: 100~240V).

- Slider Type
- Mini
- Standard
- Controllers Integrated
- Rod Type
- Mini
- Standard
- Controllers Integrated
- Table/Arm /Flat Type
- Mini
- Standard
- Gripper/ Rotary Type
- Linear Servo Type
- Cleanroom Type
- Splash-Proof
- Controllers
- PMEC /AMEC
- PSEP /ASEP
- ROBO NET
- ERC2
- PCON
- ACON
- SCON
- PSEL
- ASEL
- SSEL
- XSEL
- Pulse Motor
- Servo Motor (24V)
- Servo Motor (200V)
- Linear Servo Motor