



Slider Type (Cleanroom Type)

Lever Type (Dustproof Type)

## Features

- 1 Cleanroom specification**  
The cleanroom specification means air is extracted from inside the body of the actuator to give it a cleanroom class rating of 10 (0.1  $\mu\text{m}$ ).
- 2 Dustproof Specification**  
The dustproof specification eliminates the suction coupling of the clean specification and enables use in dusty adverse environments with IP50-equivalent dustproofing.  
\*There is no splash-proof function.
- 3 Small and lightweight, High-torque, Long strokes**  
Small, lightweight actuator, 42mm-wide, 71mm-high, weighing 200g with a 14N maximum grip strength, and 8mm open/close stroke specifications.
- 4 Multi-point positioning and adjustable grip strength**  
Servo-controlled positioning for up to 1,500 points and a capability to make fine adjustments to the grip as needed.
- 5 Two settings: Slider type and lever type**  
A two-type lineup features a guide-equipped slider type with excellent rigidity and a lever type whose lever can be opened and closed 180 degrees.

**Model**

Type	Layout	Model
Cleanroom Type	Slider Type	RCP2CR-GRSS-I-20P-30-8-P1-□
	Lever Type	RCP2CR-GRLS-I-20P-30-180-P1-□
Dustproof Type	Slider Type	RCP2W-GRSS-I-20P-30-8-P1-□
	Lever Type	RCP2W-GRLS-I-20P-30-180-P1-□

**Specification**

Item	Cleanroom Type		Dustproof Type	
	Slider Type	Lever Type	Slider Type	Lever Type
Type	Slider Type	Lever Type	Slider Type	Lever Type
Model	RCP2CR-GRSS	RCP2CR-GRLS	RCP2W-GRSS	RCP2W-GRLS
Open/Close Stroke	8 (4 per side) mm	180 (90 per side) degrees	8 (4 per side) mm	180 (90 per side) degrees
Maximum gripping force	14.0N	6.4N	14.0N	6.4N
Maximum Open/Close Speed	78 (per side) mm/s	600 (per side) deg/sec	78 (per side) mm/s	600 (per side) deg/sec
Positioning Repeatability	±0.01mm	±0.01 degrees	±0.01mm	±0.01 degrees
Static Allowable Moment (N·m)	Ma: 0.5 Mb: 0.5 Mc: 1.5	--	Ma: 0.5 Mb: 0.5 Mc: 1.5	--
Cleanliness	Class 10 (0.1µm)		---	
Suction Tube Coupling	One-touch tube coupling, Suitable tube outer diameter φ4		---	
Suction Volume	10NI/min		---	
Actuator Unit Weight	0.2kg			
Compatible Controllers	PCON / PSEL / RPCON (ROBONET)			

**External Dimensions**

**[Cleanroom Slider Type]**

(Model RCP2CR-GRSS-I-20P-30-8-P1)

**[Dustproof Slider Type]**

(Model RCP2W-GRSS-I-20P-30-8-P1)

\* Dustproof type is not equipped with an air suction coupling.

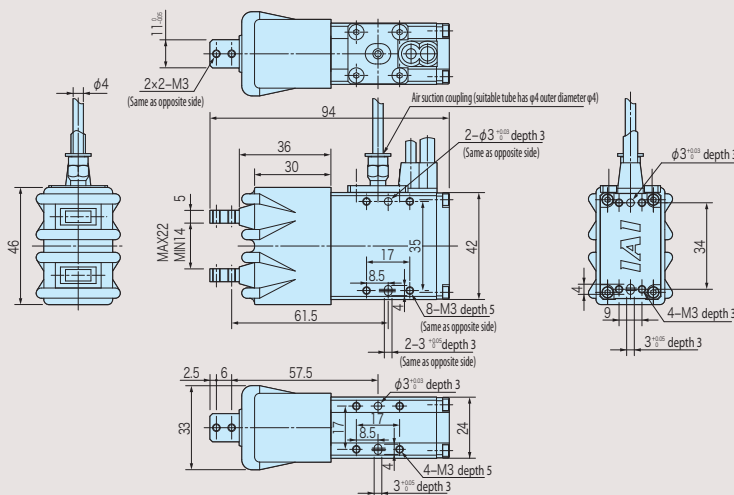

**[Cleanroom Lever Type]**

(Model RCP2CR-GRLS-I-20P-30-180-P1)

**[Dustproof Lever Type]**

(Model RCP2W-GRLS-I-20P-30-180-P1)

\* Dustproof type is not equipped with an air suction coupling.

