

# RCL-SM4L

ROBO Cylinder Slider Type Mini Multi-Slider Type 40mm Width Linear Servo Motor

**Configuration:**

RCL	SM4L	I	2	N	<input type="checkbox"/>	<input type="checkbox"/>	<input type="checkbox"/>
Series	Type	Encoder	Motor	Lead	Stroke	Compatible Controllers	Cable Length
		I: Incremental	2: 2W linear servo motor	N: No screw	30: 30mm 120: 120mm (30mm pitch increments)	A1: ACON RACON ASEL A3: AMEC ASEP	N: None P: 1m S: 3m M: 5m X <input type="checkbox"/> : Custom

\* See page Pre-35 for an explanation of the naming convention.

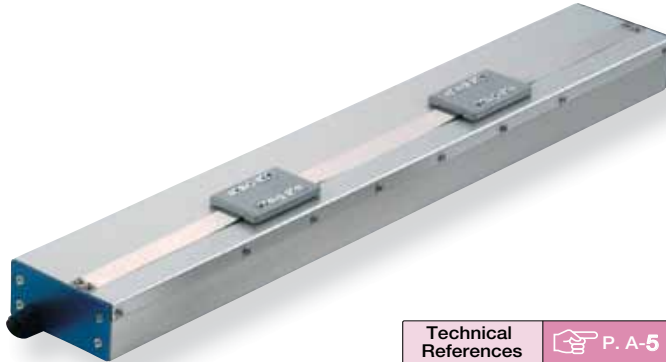

**Technical References** P. A-5

- POINT** Notes on Selection
- Please note that this type has magnetic flux leakage. (If magnetism is a problem, please use SA1L, SA2L, or SA3L)
  - The load capacity is determined by the acceleration and the duty. Check the load capacity on the Load Capacity (Horizontal) vs. Acceleration graph on the right. The duty is  $\frac{\text{Operating time}}{\text{Operating time} + \text{stationary time}} \times 100$  per cycle.
  - The mounting orientation is horizontal only. When operated vertically, please use caution, as the slider will fall when the power is turned OFF.
  - Please note that an absolute unit cannot be used.

### Load Capacity (Horizontal) vs. Acceleration

Max. Acceleration (G)	Load Capacity (kg)	
	Continuous Operation (100% duty)	
0.1	0.8	
0.3	0.8	
0.5	0.5	
1	0.25	
1.5	0.18	
2	0.14	

### Actuator Specifications

#### Lead and Load Capacity

Model	Motor Output (W)	Max. Load Capacity		Rated Thrust (N)	Max. Momentary Thrust (N)	Max. Acceleration (G)	Positioning Repeatability (mm)	Stroke (mm)
		Horizontal (kg)	Vertical (kg)					
RCL-SM4L-I-2-N- <input type="checkbox"/> - <input type="checkbox"/> - <input type="checkbox"/>	2	See table above	-	2.5	10	2	±0.1	30~120 (30mm increments)

Legend:  Stroke  Compatible controller  Cable length

#### Stroke and Maximum Speed

Lead	Stroke	30 ~ 120 (30mm increments)
	(No lead screw)	1200

(Unit: mm/s)

#### ① Stroke List

Stroke (mm)	Standard Price
30	-
60	-
90	-
120	-

#### ③ Cable List

Type	Cable Symbol	Standard Price
Standard Type (Robot Cables)	P (1m)	-
	S (3m)	-
	M (5m)	-
Special Lengths	X06 (6m) ~ X10 (10m)	-
	X11 (11m) ~ X15 (15m)	-
	X16 (16m) ~ X20 (20m)	-

\* The RCL comes standard with a robot cable.

\* See page A-39 for cables for maintenance.

### Actuator Specifications

Item	Description
Drive System	Linear servo motor
Encoder Resolution	0.042mm
Base	Material: Aluminum (white alumite treated)
Allowable Dynamic Moment (Note)	Ma: 0.2N·m Mb: 0.17N·m Mc: 0.25N·m
Overhang Load Length	Ma direction: 60mm or less Mb, Mc direction: 80mm or less
Ambient Operating Temp./Humidity	0 ~ 40°C, 85% RH or less (non-condensing)

(Note) Based on a 5,000km service life.

# 381

RCL-SM4L

Dimensions

For Special Orders P. A-9

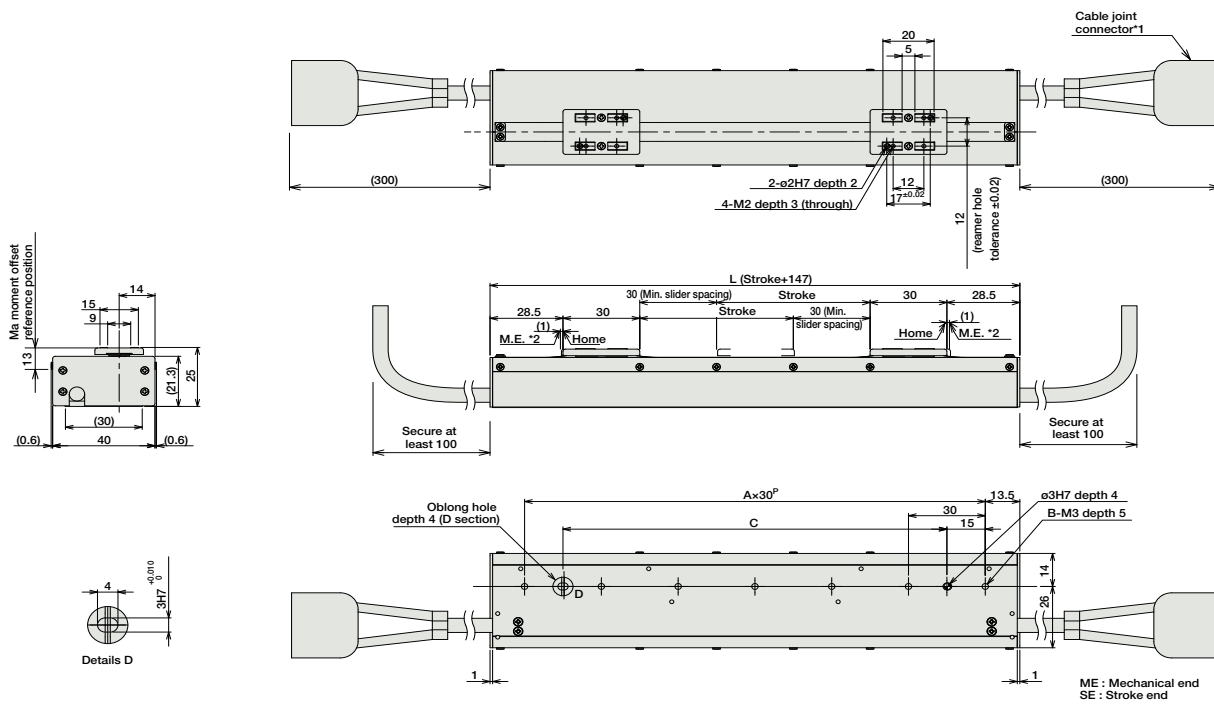

- \*1 The motor-encoder cable is connected here. See page A-39 for details on cables.
- \*2 When homing, the slider moves to the mechanical end; therefore, please watch for any interference with the surrounding objects.

**Note:**  
A controller is required for each slider.  
(or, one unit of 2-axis controller is required.)

■ Dimensions and Weight by Stroke

Stroke	30	60	90	120
L	177	207	237	267
A	5	6	7	8
B	6	7	8	9
C	120	150	180	210
Weight (kg)	0.37	0.4	0.44	0.48

② Compatible controller

The RCL series actuators can operate with the controllers below. Select the controller according to your usage.

Name	External View	Model	Description	Max. Positioning Points	Input Voltage	Power Supply Capacity	Standard Price	See Page
Solenoid Valve Type		AMEC-C-2I-NP-2-1	Easy-to-use controller, even for beginners	3 points	AC100V	2.4A rated	-	→ P477
		ASEP-C-2I-NP-2-0	Operable with same signal as solenoid valve. Supports both single and double solenoid types. No homing necessary with simple absolute type.					→ P487
Splash-Proof Solenoid Valve Type		ASEP-CW-2I-NP-2-0						
Positioner Type		ACON-C-2I-NP-2-0	Positioning is possible for up to 512 points	512 points	DC24V	4.6A max.	-	→ P535
Safety-Compliant Positioner Type		ACON-CG-2I-NP-2-0						
Pulse Train Input Type (Differential Line Driver)		ACON-PL-2I-NP-2-0	Pulse train input type with differential line driver support	(-)				
Pulse Train Input Type (Open Collector)		ACON-PO-2I-NP-2-0	Pulse train input type with open collector support					
Serial Communication Type		ACON-SE-2I-N-0-0	Dedicated to serial communication	64 points				
Field Network Type		RACON-2	Dedicated to field network	768 points				→ P503
Program Control Type		ASEL-C-1-2I-NP-2-0	Programmed operation is possible. Operation is possible on up to 2 axes	1500 points				→ P567

\* This is for the single-axis ASEL.

- Slider Type
- Mini
- Standard
- Controllers Integrated
- Rod Type
- Mini
- Standard
- Controllers Integrated
- Table/Arm /Flat Type
- Mini
- Standard
- Gripper/ Rotary Type
- Linear Servo Type
- Cleanroom Proof
- Splash Proof
- Controllers
- PMEC /AMEC
- PSEP /ASEP
- ROBO NET
- ERC2
- PCON
- ACON
- SCON
- PSEL
- ASEL
- SSEL
- XSEL
- Pulse Motor
- Servo Motor (24V)
- Servo Motor (200V)
- Linear Servo Motor