



Dimensions

For Special Order P. A-9

\*1 A motor-encoder cable is connected here. See page A-39 for details on cables.  
 \*2 When homing, the rod moves to the ME; therefore, please watch for any interference with the surrounding objects.  
 ME: Mechanical end SE: Stroke end

\*3. The orientation of the bolt will vary depending on the product.

[No Brake]

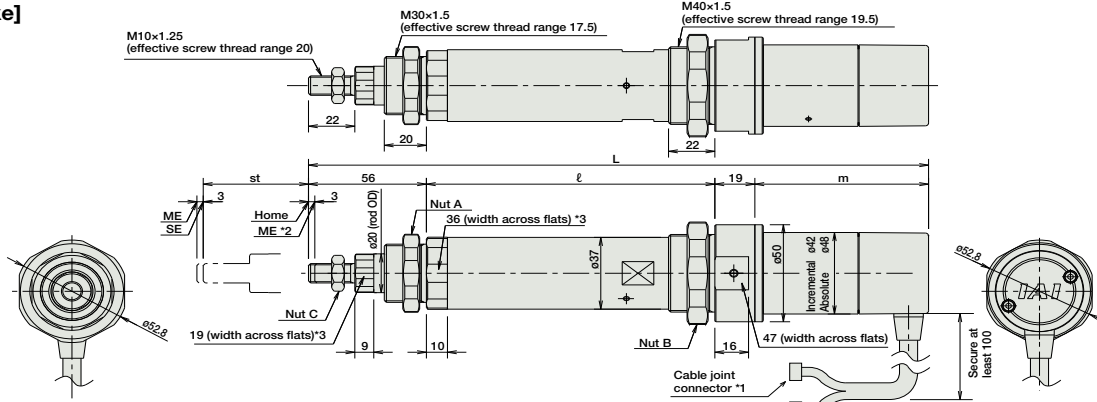

[Brake-Equipped]

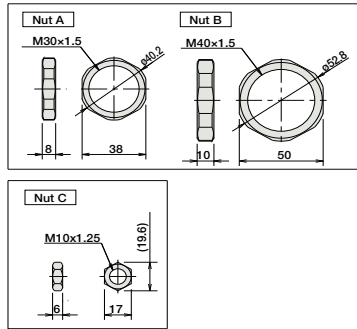
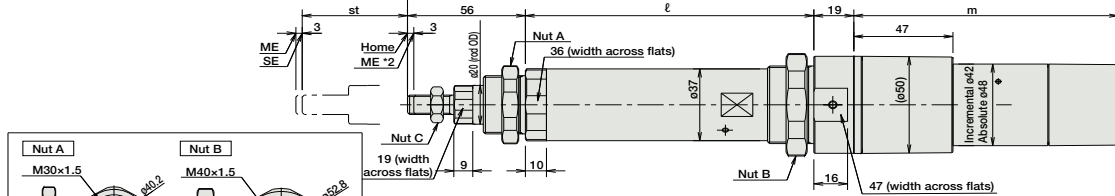

■ Dimensions/Weight by Stroke

RCA-RA4C (without brake)

Stroke	Stroke						
	50	100	150	200	250	300	
L	20W	Incr. 279.5	329.5	379.5	429.5	479.5	529.5
		Absol. 292.5	342.5	392.5	442.5	492.5	542.5
L	30W	Incr. 294.5	344.5	394.5	444.5	494.5	544.5
		Absol. 307.5	357.5	407.5	457.5	507.5	557.5
ℓ		137	187	237	287	337	387
				67.5	80.5	82.5	95.5
m	20W						
	30W						
Weight (kg)		1.1	1.2	1.4	1.5	1.7	1.8

RCA-RA4C (with brake)

Stroke	Stroke						
	50	100	150	200	250	300	
L	20W	Incr. 322.5	372.5	422.5	472.5	522.5	572.5
		Absol. 335.5	385.5	435.5	485.5	535.5	585.5
L	30W	Incr. 337.5	387.5	437.5	487.5	537.5	587.5
		Absol. 350.5	400.5	450.5	500.5	550.5	600.5
ℓ		137	187	237	287	337	387
				110.5	123.5	125.5	138.5
m	20W						
	30W						
Weight (kg)		1.3	1.4	1.6	1.7	1.9	2.0

③ Compatible Controllers

The RCA series actuators can operate with the controllers below. Select the controller according to your usage.

Name	External View	Model	Description	Max. Positioning Points	Input Voltage	Power Supply Capacity	Standard Price	See Page
Solenoid Valve Type		AMEC-C-201 ② -NP-2-1 AMEC-C-301 ② -NP-2-1	Easy-to-use controller, even for beginners	3 points	AC100V	2.4A rated	-	→ P477
		ASEP-C-201 ② -NP-2-0 ASEP-C-301 ② -NP-2-0	Operable with same signal as solenoid valve. Supports both single and double solenoid types. No homing necessary with simple absolute type.					
Splash-Proof Solenoid Valve Type		ASEP-CW-201 ② -NP-2-0 ASEP-CW-301 ② -NP-2-0						→ P487
Positioner Type		ACON-C-201 ② -NP-2-0 ACON-C-301 ② -NP-2-0	Positioning is possible for up to 512 points	512 points	DC24V	20W 1.3A rated 4.4A peak	-	→ P535
Safety-Compliant Positioner Type		ACON-CG-201 ② -NP-2-0 ACON-CG-301 ② -NP-2-0						
Pulse Train Input Type (Differential Line Driver)		ACON-PL-201 ② -NP-2-0 ACON-PL-301 ② -NP-2-0	Pulse train input type with differential line driver support	(-)	DC24V	30W 1.3A rated 4.4A peak	-	→ P503
Pulse Train Input Type (Open Collector)		ACON-PO-201 ② -NP-2-0 ACON-PO-301 ② -NP-2-0	Pulse train input type with open collector support					
Serial Communication Type		ACON-SE-201 ② -N-0-0 ACON-SE-301 ② -N-0-0	Dedicated to serial communication	64 points				
Field Network Type		RACON-20 ② RACON-30 ②	Dedicated to field network	768 points				→ P503
Program Control Type		ASEL-C-1-20 ① ② -NP-2-0 ASEL-C-1-30 ① ② -NP-2-0	Programmed operation is possible. Operation is possible on up to 2 axes	1500 points				→ P567

\* This is for the single-axis ASEL.  
 \* ① is a placeholder for the encoder type (I: incremental/A: absolute).  
 \* ② is a placeholder for the code "HA" or "LA" if the high acceleration/deceleration option or the power-saving option is specified.



RCA-RA4C **200**

- Slider Type
- Mini
- Standard
- Controllers Integrated
- Rod Type
- Mini
- Standard
- Controllers Integrated
- Table/Arm /Flat Type
- Mini
- Standard
- Gripper/ Rotary Type
- Linear Servo Type
- Cleanroom Type
- Splash Proof
- Controllers
- PMEC /AMEC
- PSEP /ASEP
- ROBO NET
- ERC2
- PCON
- ACON
- SCON
- PSEL
- ASEL
- SSEL
- XSEL
- Pulse Motor
- Servo Motor (24V)
- Servo Motor (200V)
- Linear Servo Motor