



Quality and Innovation

Program Controller  
XSEL Series 8-axis Specification

# XSEL-R/S



# Operating up to 24 robot axes with a single controller

## Low-cost, user-friendly

### XSEL 8-axis controller



## 1 Capable of interpolation operation involving up to 8 axes

Up to eight axes, in any combination of single-axis, Cartesian and SCARA robots, can be connected and operated in an interpolation mode. This configuration reduces the installation space and equipment size compared to when two conventional 4-axis controllers are operated. Programming is also easy, because a single command operates all eight axes.

### Combination example

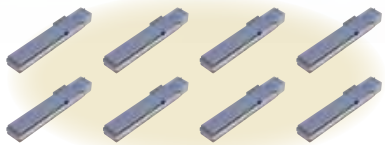

Synchronous control of eight single axes

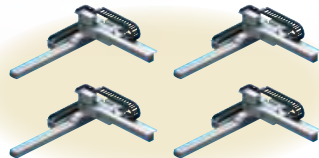

Synchronous control of four Cartesian 2-axis robots

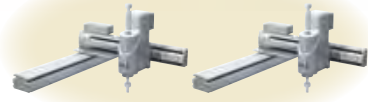

Synchronous control of two Cartesian 4-axis robots

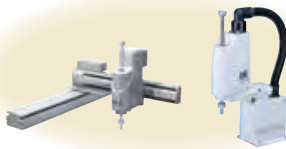

Synchronous control of Cartesian 4-axis robot and SCARA robot



Synchronous control of two SCARA robots

## 2 DeviceNet master function (RC Gateway function)

Option

Up to 16 axes operated by DeviceNet PCON/ACON/SCON, MSEP and/or MSCON controllers can be connected and operated from an XSEL controller using its program.

Up to 24 axes, including the eight axes connected to the XSEL controller, can be operated with a single controller, and since peripherals can also be controlled by I/Os, PLC is no longer necessary and consequently the cost can be reduced.

\* Similar control is also possible via RS232 communication instead of using DeviceNet.

Able to operate axes connected to MSCON, MSEP and/or PCON/ACON/SCON-CA controllers from an XSEL controller using its program.

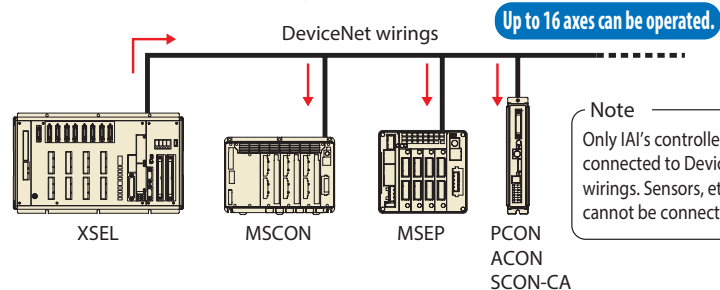

Note  
Only IAI's controllers can be connected to DeviceNet wirings. Sensors, etc., cannot be connected.

# 3

## Supporting EtherCAT and EtherNet/IP

Option

EtherCAT and EtherNet/IP are now supported in addition to DeviceNet, CC-Link and ProfiBUS. "DeviceNet, CC-Link or ProfiBUS(\*)" "EtherCAT or EtherNet/IP(\*)" and "DevicNet Master Function" can be used simultaneously.

(\*) For the functions used simultaneously, select one of DeviceNet, CC-Link and ProfiBUS, and select either EtherCAT or EtherNet/IP.



# 4

## IA net function

Option

XSEL controllers (\*) can be interconnected via network to perform I/O communication between the controllers. I/Os can be added using the expansion I/O unit.

Since all controllers connected to the IA net permit data monitoring and input using the PC software connected to a single controller, this setting is ideal for systems that use multiple controllers, etc.

(\*) XSEL-R/RX/RXD/S/SX/SXD controllers can be connected.

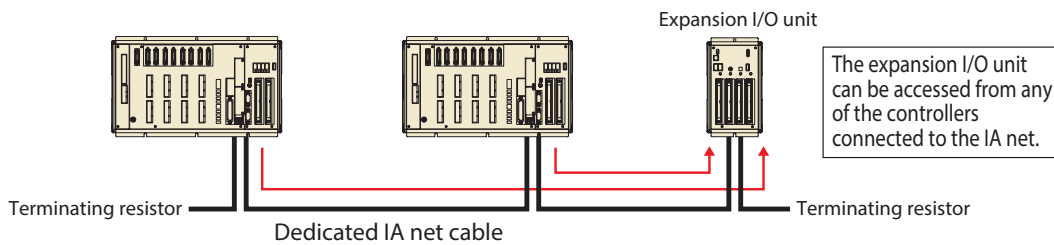

# 5

## Function to count the number of movements/travelled distance (maintenance functions)

The "total number of movements" and "total distance travelled" can be counted for each connected axis. When the count exceeds the set value, an I/O (input/output signal) can be turned ON to notify an external device. Accordingly, this function can be used to notify when to add grease to or perform maintenance on each axis.



## ■ SCARA / Single-axis/Cartesian specification XSEL-RX□ type/SX□ type

(Specs for axis 5 – 8)

**XSEL** - □ - □ - (□ □ □) - □ □ □ - □ □ - □ - □

series    Type    SCARA robot type    Motor    Encoder    Option    Dedicated network slot (Slot 1) (Slot 2) (Slot 3)    I/O slot (Slot 1) (Slot 2)    I/O cable length    Power/voltage

RX4	SCARA x 1		I	Incremental		E	Not used	E	Not used		
RX5	SCARA + 1-axis		A	Absolute		IA	IA net-compatible	N1	Input 32/Output 16 (NPN)		
RX6	SCARA + 2-axis		G	Quasi-absolute				N2	Input 16/Output 32 (NPN)		
RX7	SCARA + 3-axis							N3	Input 48/Output 48 (NPN)		
RX8	SCARA + 4-axis							P1	Input 32/Output 16 (PNP)		
SX4	SCARA x 1 Global specification		B	Brake-equipped specification				P2	Input 16/Output 32 (PNP)		
SX5	SCARA + 1-axis Global specification		C	Creep sensor specification				P3	Input 48/Output 48 (PNP)		
SX6	SCARA + 2-axis Global specification		L	Home sensor/LS-compatible				DG	DeviceNet Gateway master board		
SX7	SCARA + 3-axis Global specification		M	Master axis spec							
SX8	SCARA + 4-axis Global specification		S	Slave axis spec							

NNN1205~8040H	Standard type	TNN3015H~3515H	Wall mount type
NSN5016H~6016H	High speed type	UNN3015H~3515H	Wall mount inverse type
NNC1205~8040H	Clean room type	HNN5020H~8040H	Ceiling mount type
NNW2515H~8040H	Splash-proof type	INN5020H~8040H	Inverse type

12	12 W	150	150 W
20	20 W	200	200 W
30D	30 W for DS	200S	200 W for linear
30R	30 W for RS	300	300 W
60	60 W	400	400 W
100	100 W	600	600 W
100S	100 W for linear	750	750 W

0	No cable
2	2m (standard)
3	3m
5	5m

3	Three-phase 200 V
---	-------------------

(\*) Slots 1 to 3 are dedicated network slots where the selectable boards are fixed. Select one of the specified boards and enter the corresponding code.  
 (\*) The above I/O boards can be installed in both I/O slots 1 and 2, but you can specify "DG" (DeviceNet Gateway board) only for slot 1.  
 (\*) The dedicated network slots and I/O slots can be used at the same time.

### \* Notes on selecting single-axis robots

The conditions for connectable single-axis robots change according to the type of the SCARA robot to be operated. For details, refer to the notes on the back cover.

## ■ SCARA x 2 Specification XSEL-RXD8 type/SXD8 type

**XSEL** - □ - □ - □ - □ □ □ □ - □ □ □ - □ □ - □ - □

series    Type    SCARA robot type 1    SCARA robot type 2    Dedicated network slot (Slot 1) (Slot 2) (Slot 3)    I/O slot (Slot 1) (Slot 2)    I/O cable length    Power/voltage

RXD8	For connecting 2 SCARA robots					E	Not used	E	Not used		
SXD8	For connecting 2 SCARA robots Global specification					IA	IA net-compatible	N1	Input 32/Output 16 (NPN)		
								N2	Input 16/Output 32 (NPN)		
								N3	Input 48/Output 48 (NPN)		
								P1	Input 32/Output 16 (PNP)		
								P2	Input 16/Output 32 (PNP)		
								P3	Input 48/Output 48 (PNP)		
								DG	DeviceNet Gateway master board		

NNN1205~6030H	Standard type
NNC1205~6030H	Clean room type
NNW2515H~6030H	Splash-proof type
TNN3015H~3515H	Wall mount type
UNN3015H~3515H	Wall mount inverse type
HNN5020H~6020H	Ceiling mount type
INN5020H~6020H	Inverse type

E	Not used
DV	DeviceNet
CC	CC-Link
PR	PROFIBUS-DP

E	Not used
EP	EtherNet/IP
EC	EtherCAT

0	No cable
2	2m (standard)
3	3m
5	5m

3	Three-phase 200 V
---	-------------------

(\*) The RXD8/SXD8 controllers are each used to connect two SCARA robots. Use the RX4 or SX4 controller when only one SCARA robot is operated.  
 (\*) Slots 1 to 3 are dedicated network slots where the selectable boards are fixed. Select one of the specified boards and enter the corresponding code.  
 (\*) The above I/O boards can be installed in both I/O slots 1 and 2, but you can specify "DG" (DeviceNet Gateway board) only for slot 1.  
 (\*) The dedicated network slots and I/O slots can be used at the same time.

### \* Notes on selecting SCARA robots

The second SCARA robot to be connected is limited according to the type of the first SCARA robot connected. For details, refer to the notes on the back cover.

# XSEL Controller

## System Configuration

### XSEL-R/RX/RXD type (Standard specification)

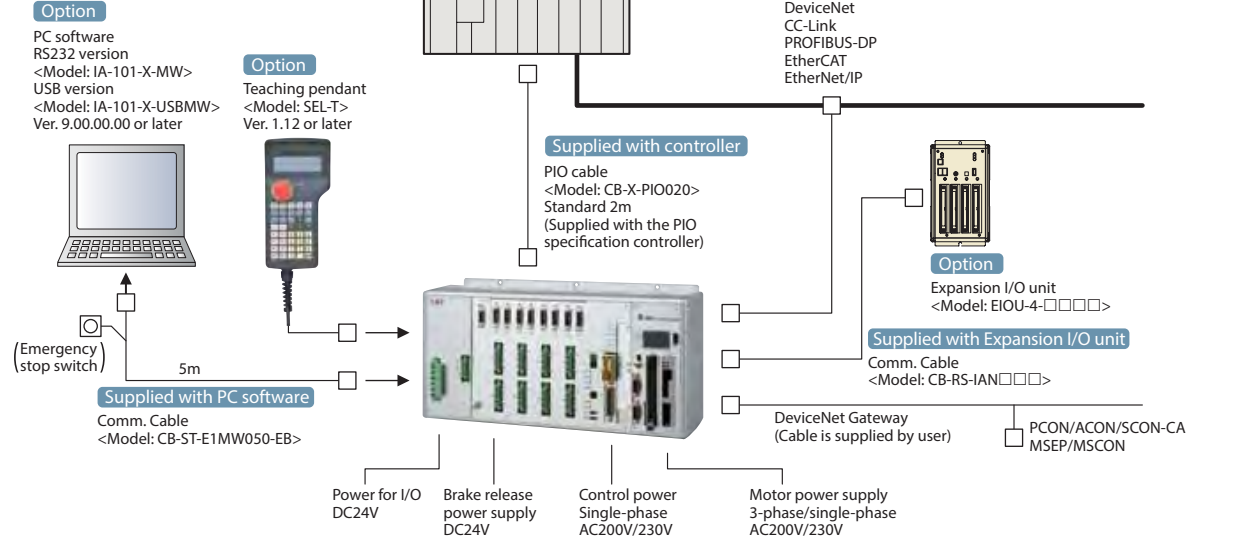

### XSEL-S/SX/SXD type (Global specification)

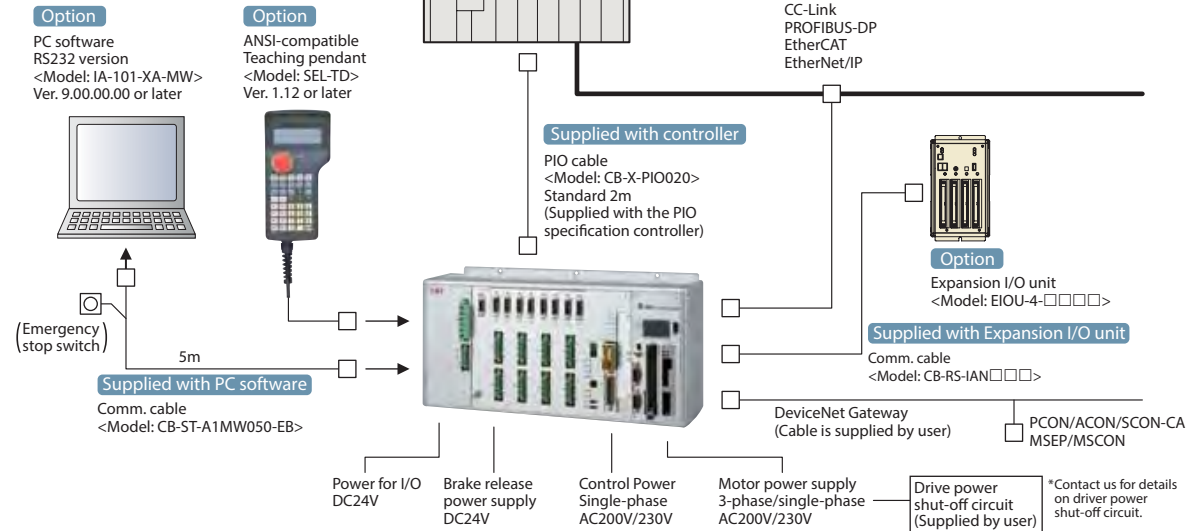

## Expansion I/O Unit

- **Features** ① Up to four expansion I/O boards can be added. (For the I/Os, up to 192 input points/192 output points can be added.)
- ② The expansion I/O unit can be shared by multiple XSEL controllers(\*).  
Note: Input signals from one expansion I/O board can be shared by multiple controllers, but output signals from one expansion I/O board should be used by only one controller.
- (\* This function is available only with XSEL-R/S/RX/SX/RXD/SXD controllers.
- \* If the expansion I/O unit is used, select "IA net-compatible" when specifying the controller model.

### ■ Features EIOU-4-(Slot 1 code) (Slot 2 code) (Slot 3 code) (Slot 4 code)

\* Enter in each slot code field the code of the expansion I/O board to be added to the expansion I/O unit.

#### <Expansion I/O board codes>

E	Not used	N1	Input 32/Output 16 (NPN)	P1	Input 32/Output 16 (PNP)
		N2	Input 16/Output 32 (NPN)	P2	Input 16/Output 32 (PNP)
		N3	Input 48/Output 48 (NPN)	P3	Input 48/Output 48 (PNP)

### External dimensional drawing

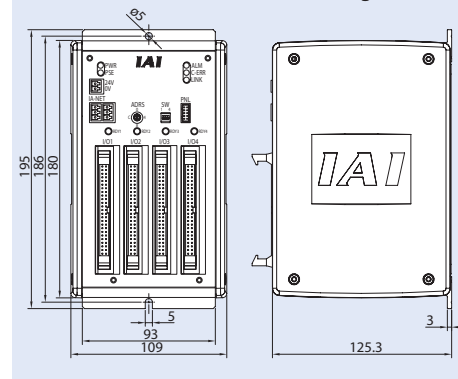

## RC Gateway Function (DeviceNet Specification/ SIO Specification)

- **Features** Up to 16 actuator axes can be operated with a XSEL controller program, with the XSEL controller acting as the master and each ROBO Cylinder controller as a slave.  
One of the following two methods can be selected for communication among the controllers.

Type	Comm. method	Comm. speed	How to use
DeviceNet specification	DeviceNet	500 kbps	The DeviceNet Gateway master board must be installed in an I/O slot of the XSEL controller. Specify "DG" as the I/O slot type for the XSEL controller.
SIO specification	RS232C	230.4kbps	Use the 2-channel communication port (standard equipment) of the XSEL controller. To connect slave controllers, the dedicated 2-channel connection port cable is needed. (Model: CB-RS-SIO005, length 0.5 m)

\* Contact us for the wiring and setting methods for the RC Gateway function.

## Specification Table

Controller type	R type	RX/RXD8 type	S type	SX/SXD8 type
Applicable motor output	12W to 750W			
Number of control axes	1 to 8 axes			
Maximum connected axes output	[Three-phase specification] 2400W max. [Single-phase specification] 1600W max.	[Three-phase specification] 2400W max.	[Three-phase specification] 2400W max. [Single-phase specification] 1600W max.	[Three-phase specification] 2400W max.
Control power-supply input	Single-phase AC200/230V ± 10%			
Power supply frequency	50/60 Hz			
Insulation resistance	10 MΩ or more (500-VDC reading between the power-supply terminal and I/O terminal, and between all external terminals and the case)			
Withstand voltage	AC1500V (1 minute)			
Power-supply capacity (max.)	5094 VA (at the maximum output of connected axes)			
Position detection method	Only incremental/absolute encoders of serial communication type are supported (for all axes).			
Safety circuit configuration	Redundancy not supported		Double Redundant Enabled	
Drive source breaker system	Internal cutoff relay		External safety circuit	
Emergency stop input	B Contact Input (Internal Power Supply Model)		B Contact Input (External Power Supply Model, Double Redundant)	
Enable input	B Contact Input (Internal Power Supply Model)		B Contact Input (External Power Supply Model, Double Redundant)	
Speed setting	1 mm/sec and up, the maximum depends on the actuator specifications			
Acceleration/Deceleration setting	0.01 G and up, the maximum depends on the actuator specifications			
Programming language	Super SEL language			
Number of programs	128 programs			
Number of program steps	9999 steps (total)			
Number of multi-tasking programs	16 programs			
Number of positions	Varies depending on the number of controlled axes. 6 axes: 20000 positions, 8 axes: 16000 positions (total)			
Data memory device	Flash ROM + non-volatile RAM (FRAM): System battery (button battery) not required			
Data input method	Teaching pendant or PC			
Standard input/output	2 boards can be installed, including a PIO board of 48 I/O points (NPN/PNP) and a PIO board of 96 I/O points (NPN/PNP)			
Expansion input/output	None (A separate expansion I/O unit can be used to add up to 4 PIO boards.)			
Serial communications function	Teaching port (D-sub 25 pins), 2-channel RS232C ports (D-sub 9 pins) Baud rate: 115.2 kbps max.			
IA net	Number of connected units: 64 controllers / Baud rate: 12 Mbps, fixed			
RC Gateway function	RS232C communication port (Channel 2 only) or DeviceNet Gateway master board port.			
Fieldbus communication function	DeviceNet, CC-LINK, Profibus, EtherNet/IP, EtherCAT (One of EtherNet/IP and EtherCAT, and one of DeviceNet, CC-LINK and Profibus, can be supported at the same time.)			
Clock function	Retention time: Approx. 10 days Charge time: Approx. 100 hours			
Display unit	Optional panel unit (PU-1) can be connected.			
Regenerative resistance	Built-in regenerative resistor of 1 kΩ/20 W (External regenerative resistor unit(s) can be connected.)			
Absolute battery	AB-5 (built into the controller)			
Protection function	Motor overcurrent, overload, motor driver temperature check, overload check, encoder open-circuit check, soft limit over, system error, battery error, etc.			
Ambient operating temp/humidity	0 to 40°C, 85% RH or less (non-condensing). Free from corrosive gases. In particular, there shall be no significant dust.			

\* Refer to the operation manual or contact us for the power-supply capacity, etc.

## External Dimensions

		Front view		Side view	
		Incremental specification	Absolute specification		
R RX RXD (Note 1)	3-phase				
	Single-phase				
S SX SXD (Note 1)	3-phase				
	Single-phase				
					(Common)

(Note 1) If any one of the connected axes is of absolute specification, the external dimensions for absolute specification shall apply. Note, however, that the external dimensions for incremental specification shall apply to SCARA robots of RX4/SX4/RXD8/SXD8 types because the battery is installed in the SCARA robot. If axes for RX/SX other than SCARA robots are of absolute specification, the external dimensions for absolute specification shall apply.

## Notes on Using Controllers

- Note that the models specified below cannot be operated with the XSEL-R/RX/S/SX types. Linear servo actuators (other than the LSAS Series), RCS2-□□5N, RCS2-SRA7BD/SRGS7BD/SRGD7BD, NS-SXM□/SZM□ (all incremental specifications only)
- With the XSEL-RX/SX types, the conditions for connectable single-axis/Cartesian robots vary depending on the SCARA robot to be connected. For details, refer to the table below.

SCARA robot model	Single-axis robot conditions
IX-NNN1205/1505/1805	1500W max. as the total of 4 axes, 750W max. per axis
IX-NNN2515H/3015H/3515H	
IX-NNN50□□H□60□□H	600W max. as the total of 4 axes, 600W max. per axis
IX-NNN70□□H□80□□H	Connection not possible
IX-NSN5016H/6016H	

\*The same SCARA robot models apply to wall-mounted, ceiling, clean room and splash-proof specifications.

- With the XSEL-RXD/SXD types, some combinations do not permit the second SCARA robot to be connected depending on the type of the first SCARA robot connected. For details, refer to the table below.

SCARA robot [1] model	Models connectable as SCARA robot [2]
IX-NNN1205/1505/1805	IX-NNN1205/1505/1805/2515H/3015H/3515H/50□□H/60□□H
IX-NNN2515H/3015H/3515H	IX-NNN1205/1505/1805/2515H/3015H/3515H
IX-NNN50□□H/60□□H	IX-NNN1205/1505/1805

\*The same SCARA robot models apply to wall-mounted, ceiling, clean room and splash-proof specifications.

\*Types larger than the IX-NNN70□□ cannot be operated with the RXD8/SXD8.