

Linear Servo Type



Linear Servo Type

RCL



RCL-SA1L



RCL-SA2L



RCL-SA3L



RCL-SA4L



RCL-SA5L



RCL-SA6L



RCL-SM4L



RCL-SM5L



RCL-SM6L



RCL-RA1L

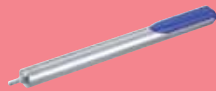

RCL-RA2L



RCL-RA3L

371

Linear Servo Type

Sold & Serviced By:

 **ELECTROMATE**

Toll Free Phone (877) SERV098

Toll Free Fax (877) SERV099

www.electromate.com

sales@electromate.com

RCL
series
Linear Servo
Motor Type

Slider Type	Mini Slim Model	20mm Width	RCL-SA1L	373	
		24mm Width	RCL-SA2L	375	
		28mm Width	RCL-SA3L	377	
		Mini Long Stroke Type	40mm Width	RCL-SA4L	379
			48mm Width	RCL-SA5L	383
			58mm Width	RCL-SA6L	387
	Mini Multi-Slider Type	40mm Width	RCL-SM4L	381	
		48mm Width	RCL-SM5L	385	
		58mm Width	RCL-SM6L	389	
	Rod Type	Mini Slim Type	ø16mm	RCL-RA1L	391
			ø20mm	RCL-RA2L	393
			ø25mm	RCL-RA3L	395

Slider Type

Mini

Standard

Controllers Integrated

Rod Type

Mini

Standard

Controllers Integrated

Table/Arm /Flat Type

Mini

Standard

Gripper/ Rotary Type

Linear Servo Type

Cleanroom Type

Splash Proof

Controllers

PMEC /AMEC

PSEP /ASEP

ROBO NET

ERC2

PCON

ACON

SCON

PSEL

ASEL

SSEL

XSEL

Pulse Motor

Servo Motor (24V)

Servo Motor (200V)

Linear Servo Motor

RCL-SA1L

ROBO Cylinder Slider Type Mini-Slim Type 20mm Width Linear Servo Motor

■ Configuration: **RCL** — **SA1L** — **I** — **2** — **N** — **40** — —

Series — Type — Encoder — Motor — Lead — Stroke — Compatible Controllers — Cable Length

I: Incremental 2: 2W linear servo motor N: No screw 40: 40mm

A1: ACON N: None
 RACON P: 1m
 ASEL S: 3m
 A3: AMEC M: 5m
 ASEP X : Custom

* See page Pre-35 for an explanation of the naming convention.

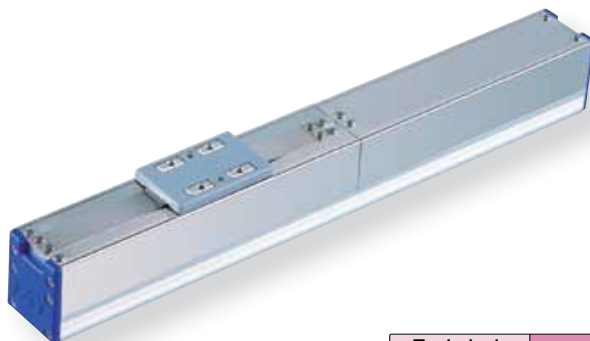

Technical References P. A-5

POINT Notes on Selection

(1) The load capacity is determined by the acceleration and the duty. Check the load capacity on the Load Capacity (Horizontal) vs. Acceleration graph on the right. The duty is $\frac{\text{Operating time}}{\text{Operating time} + \text{stationary time}} \times 100$ per cycle.

(2) The mounting orientation is horizontal only. When operated vertically, please use caution, as the slider will fall when the power is turned OFF.

(3) Please note that an absolute unit cannot be used.

Load Capacity (Horizontal) vs. Acceleration

Max. Acceleration (G)	Load Capacity (kg)	
	Continuous Operation (100% duty)	(70% or less duty)
0.1	0.5	0.5
0.3		
0.5	0.42	
1	0.25	0.32
1.5	0.18	0.24
2	0.15	0.2

Actuator Specifications

Lead and Load Capacity

Model	Motor Output (W)	Max. Load Capacity		Rated Thrust (N)	Max. Momentary Thrust (N)	Max. Acceleration (G)	Positioning Repeatability (mm)	Stroke (mm)
		Horizontal (kg)	Vertical (kg)					
RCL-SA1L-I-2-N-40-①-②	2	See table above	-	2	10	2	±0.1	40 (Fixed)

Legend: ① Compatible controller ② Cable length

Stroke and Maximum Speed

Lead	Stroke	40 (mm)
	(No lead screw)	

(Unit: mm/s)

Stroke List

Stroke (mm)	Standard Price
40	-

② Cable List

Type	Cable Symbol	Standard Price
Standard Type (Robot Cables)	P (1m)	-
	S (3m)	-
	M (5m)	-
Special Lengths	X06 (6m) ~ X10 (10m)	-
	X11 (11m) ~ X15 (15m)	-
	X16 (16m) ~ X20 (20m)	-
		-

* The RCL comes standard with a robot cable.

* See page A-39 for cables for maintenance.

Actuator Specifications

Item	Description
Drive System	Linear servo motor
Encoder Resolution	0.042mm
Base	Material: Aluminum (white alumite treated)
Allowable Dynamic Moment (Note)	Ma: 0.13N·m Mb: 0.12N·m Mc: 0.21N·m
Overhang Load Length	50mm or less
Ambient Operating Temp./Humidity	0~40°C, 85% RH or less (non-condensing)

(Note) Based on a 5,000km service life.

373

RCL-SA1L

- Slider Type
- Mini
- Standard
- Controllers Integrated
- Rod Type
- Mini
- Standard
- Controllers Integrated
- Table/Arm/Flat Type
- Mini
- Standard
- Gripper/Rotary Type
- Linear Servo Type
- Cleanroom Proof
- Splash Proof
- Controllers
- PMEC/AMEC
- PSEP/ASEP
- ROBO NET
- ERC2
- PCON
- ACON
- SCON
- PSEL
- ASEL
- SSEL
- XSEL
- Pulse Motor
- Servo Motor (24V)
- Servo Motor (200V)
- Linear Servo Motor

Dimensions

For Special Orders P. A-9

- *1 The motor-encoder cable is connected here. See page A-39 for details on cables.
- *2 When homing, the slider moves to the mechanical end; therefore, please watch for any interference with the surrounding objects.

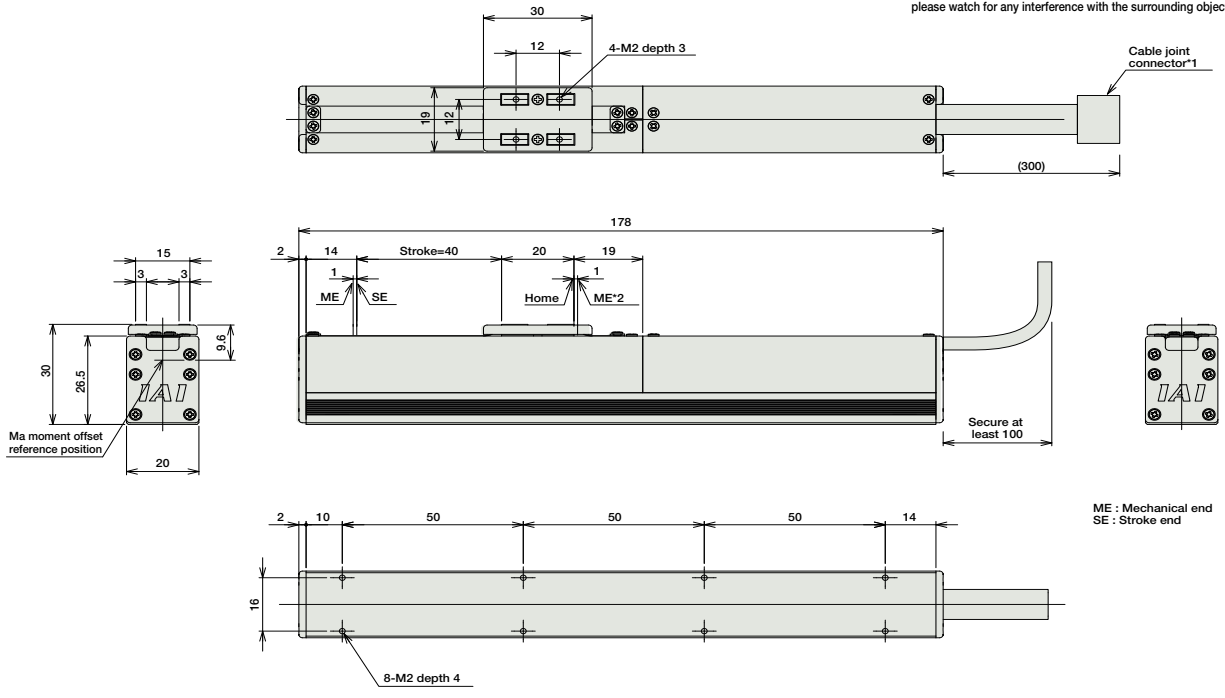

ME : Mechanical end
SE : Stroke end

■ Dimensions and Weight by Stroke

Stroke	40
Weight (kg)	0.28

① Compatible Controllers

The RCL series actuators can operate with the controllers below. Select the controller according to your usage.

Name	External View	Model	Description	Max. Positioning Points	Input Voltage	Power Supply Capacity	Standard Price	See Page
Solenoid Valve Type		AMEC-C-2I-NP-2-1	Easy-to-use controller, even for beginners	3 points	AC100V	2.4A rated	-	→ P477
		ASEP-C-2I-NP-2-0	Operable with same signal as solenoid valve. Supports both single and double solenoid types. No homing necessary with simple absolute type.				-	→ P487
Splash-Proof Solenoid Valve Type		ASEP-CW-2I-NP-2-0					-	
Positioner Type		ACON-C-2I-NP-2-0	Positioning is possible for up to 512 points	512 points	DC24V	4.6A max.	-	→ P535
Safety-Compliant Positioner Type		ACON-CG-2I-NP-2-0					-	
Pulse Train Input Type (Differential Line Driver)		ACON-PL-2I-NP-2-0	Pulse train input type with differential line driver support	(-)	DC24V	4.6A max.	-	→ P535
Pulse Train Input Type (Open Collector)		ACON-PO-2I-NP-2-0	Pulse train input type with open collector support				-	
Serial Communication Type		ACON-SE-2I-N-0-0	Dedicated to serial communication	64 points			-	
Field Network Type		RACON-2	Dedicated to field network	768 points			-	→ P503
Program Control Type		ASEL-C-1-2I-NP-2-0	Programmed operation is possible. Operation is possible on up to 2 axes	1500 points			-	→ P567

* This is for the single-axis ASEL.

- Slider Type
- Mini
- Standard
- Controllers Integrated
- Rod Type
- Mini
- Standard
- Controllers Integrated
- Table/Arm /Flat Type
- Mini
- Standard
- Gripper/ Rotary Type
- Linear Servo Type
- Cleanroom Proof
- Splash Proof
- Controllers
- PMEC /AMEC
- PSEP /ASEP
- ROBO NET
- ERC2
- PCON
- ACON
- SCON
- PSEL
- ASEL
- SSEL
- XSEL
- Pulse Motor
- Servo Motor (24V)
- Servo Motor (200V)
- Linear Servo Motor



RCL-SA1L **374**

RCL-SA2L

ROBO Cylinder Slider Type Mini-Slim Type 24mm Width Linear Servo Motor

■ Configuration: **RCL** — **SA2L** — **I** — **5** — **N** — **48** — —

Series — Type — Encoder — Motor — Lead — Stroke — Compatible Controllers — Cable Length

I: Incremental 5: 5W linear servo motor N: No screw 48: 48mm

A1: ACON N: None
 RACON P: 1m
 ASEL S: 3m
 A3: AMEC M: 5m
 ASEP X : Custom

* See page Pre-35 for an explanation of the naming convention.

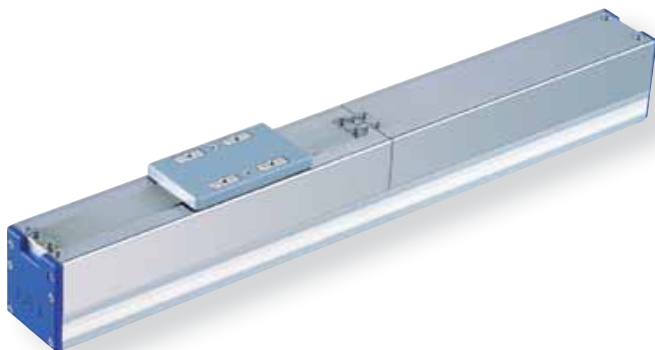

Technical References P. A-5

- POINT** Notes on Selection
- The load capacity is determined by the acceleration and the duty. Check the load capacity on the Load Capacity (Horizontal) vs. Acceleration graph on the right. The duty is $\frac{\text{Operating time}}{\text{Operating time} + \text{stationary time}} \times 100$ per cycle.
 - The mounting orientation is horizontal only. When operated vertically, please use caution, as the slider will fall when the power is turned OFF.
 - Please note that an absolute unit cannot be used.

Load Capacity (Horizontal) vs. Acceleration

Max. Acceleration (G)	Load Capacity (kg)	
	Continuous Operation (100% duty)	(70% or less duty)
0.1	1	1
0.3		
0.5	0.85	
1	0.5	0.6
1.5	0.36	0.45
2	0.3	0.36

Actuator Specifications

Lead and Load Capacity

Model	Motor Output (W)	Max. Load Capacity		Rated Thrust (N)	Max. Momentary Thrust (N)	Max. Acceleration (G)	Positioning Repeatability (mm)	Stroke (mm)
		Horizontal (kg)	Vertical (kg)					
RCL-SA2L-I-5-N-48-①-②	5	See table above	-	4	18	2	±0.1	48 (Fixed)

Legend: ① Compatible controller ② Cable length

Stroke and Maximum Speed

Lead	Stroke	48 (mm)
	(No lead screw)	

(Unit: mm/s)

Stroke List

Stroke (mm)	Standard Price
48	-

② Cable List

Type	Cable Symbol	Standard Price
Standard Type (Robot Cables)	P (1m)	-
	S (3m)	-
	M (5m)	-
Special Lengths	X06 (6m) ~ X10 (10m)	-
	X11 (11m) ~ X15 (15m)	-
	X16 (16m) ~ X20 (20m)	-
		-

* The RCL comes standard with a robot cable.
 * See page A-39 for cables for maintenance.

Actuator Specifications

Item	Description
Drive System	Linear servo motor
Encoder Resolution	0.042mm
Base	Material: Aluminum (white alumite treated)
Allowable Dynamic Moment (Note)	Ma: 0.2N·m Mb: 0.17N·m Mc: 0.25N·m
Overhang Load Length	60mm or less
Ambient Operating Temp./Humidity	0~40°C, 85% RH or less (non-condensing)

(Note) Based on a 5,000km service life.

375

RCL-SA2L

- Slider Type
- Mini
- Standard
- Controllers Integrated
- Rod Type
- Mini
- Standard
- Controllers Integrated
- Table/Arm/Flat Type
- Mini
- Standard
- Gripper/Rotary Type
- Linear Servo Type
- Cleanroom Proof
- Splash Proof
- Controllers
- PMEC/AMEC
- PSEP/ASEP
- ROBO NET
- ERC2
- PCON
- ACON
- SCON
- PSEL
- ASEL
- SSEL
- XSEL
- Pulse Motor
- Servo Motor (24V)
- Servo Motor (200V)
- Linear Servo Motor

Dimensions

For Special Orders P. A-9

- *1 The motor-encoder cable is connected here. See page A-39 for details on cables.
- *2 When homing, the slider moves to the mechanical end; therefore, please watch for any interference with the surrounding objects.

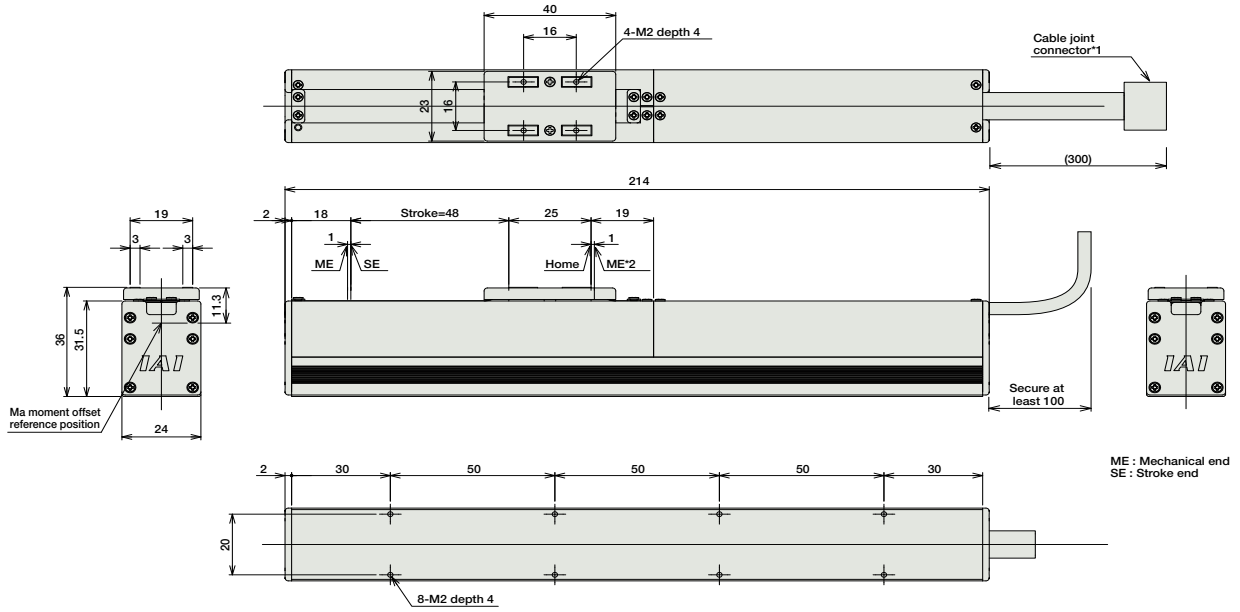

■ Dimensions and Weight by Stroke

Stroke	48
Weight (kg)	0.45

① Compatible Controllers

The RCL series actuators can operate with the controllers below. Select the controller according to your usage.

Name	External View	Model	Description	Max. Positioning Points	Input Voltage	Power Supply Capacity	Standard Price	See Page
Solenoid Valve Type		AMEC-C-5I-NP-2-1	Easy-to-use controller, even for beginners	3 points	AC100V	2.4A rated	-	→ P477
Splash-Proof Solenoid Valve Type		ASEP-C-5I-NP-2-0	Operable with same signal as solenoid valve. Supports both single and double solenoid types. No homing necessary with simple absolute type.				-	→ P487
Positioner Type		ACON-C-5I-NP-2-0	Positioning is possible for up to 512 points	512 points	DC24V	6.4A max.	-	→ P535
Safety-Compliant Positioner Type		ACON-CG-5I-NP-2-0					-	
Pulse Train Input Type (Differential Line Driver)		ACON-PL-5I-NP-2-0	Pulse train input type with differential line driver support	(-)	DC24V	6.4A max.	-	→ P535
Pulse Train Input Type (Open Collector)		ACON-PO-5I-NP-2-0	Pulse train input type with open collector support				-	
Serial Communication Type		ACON-SE-5I-N-0-0	Dedicated to serial communication	64 points	DC24V	6.4A max.	-	→ P503
Field Network Type		RACON-5	Dedicated to field network	768 points	DC24V	6.4A max.	-	→ P503
Program Control Type		ASEL-C-1-5I-NP-2-0	Programmed operation is possible. Operation is possible on up to 2 axes	1500 points	DC24V	6.4A max.	-	→ P567

* This is for the single-axis ASEL.

IAI

RCL-SA2L **376**

- Slider Type
- Mini
- Standard
- Controllers Integrated
- Rod Type
- Mini
- Standard
- Controllers Integrated
- Table/Arm /Flat Type
- Mini
- Standard
- Gripper/ Rotary Type
- Linear Servo Type
- Cleanroom Proof
- Splash Proof
- Controllers
- PMEC /AMEC
- PSEP /ASEP
- ROBO NET
- ERC2
- PCON
- ACON
- SCON
- PSEL
- ASEL
- SSEL
- XSEL
- Pulse Motor
- Servo Motor (24V)
- Servo Motor (200V)
- Linear Servo Motor

RCL-SA3L ROBO Cylinder Slider Type Mini-Slim Type 28mm Width Linear Servo Motor

■ Configuration: **RCL** — **SA3L** — **I** — **10** — **N** — **64** — —
 Series — Type — Encoder — Motor — Lead — Stroke — Compatible Controllers — Cable Length
 I: Incremental 10: 10W linear servo motor N: No screw 64: 64mm
 A1: ACON RACON ASEL A3: AMEC ASEP N: None P: 1m S: 3m M: 5m X : Custom

* See page Pre-35 for an explanation of the naming convention.

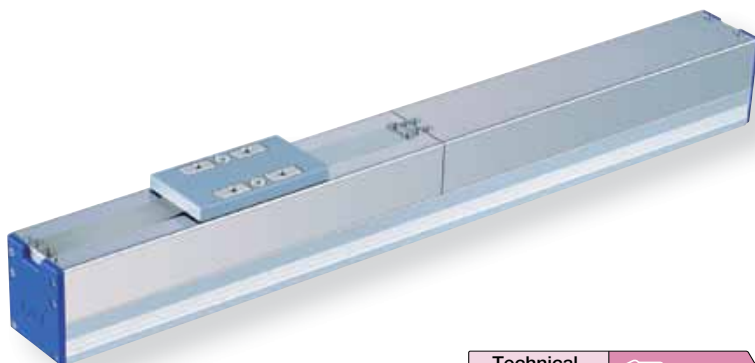

Technical References P. A-5

- POINT** Notes on Selection
- The load capacity is determined by the acceleration and the duty. Check the load capacity on the Load Capacity (Horizontal) vs. Acceleration graph on the right. The duty is $\frac{\text{Operating time}}{\text{Operating time} + \text{stationary time}} \times 100$ per cycle.
 - The mounting orientation is horizontal only. When operated vertically, please use caution, as the slider will fall when the power is turned OFF.
 - Please note that an absolute unit cannot be used.

Load Capacity (Horizontal) vs. Acceleration

Max. Acceleration (G)	Load Capacity (kg)	
	Continuous Operation (100% duty)	(70% or less duty)
0.1	2	2
0.3		
0.5	1.8	
1	1	1.2
1.5	0.65	0.8
2	0.5	0.6

Actuator Specifications

Lead and Load Capacity

Model	Motor Output (W)	Max. Load Capacity		Rated Thrust (N)	Max. Momentary Thrust (N)	Max. Acceleration (G)	Positioning Repeatability (mm)	Stroke (mm)
		Horizontal (kg)	Vertical (kg)					
RCL-SA3L-I-10-N-64-①-②	10	See table above	-	8	30	2	±0.1	64 (Fixed)

Legend: ① Compatible controller ② Cable length

Stroke and Maximum Speed

Stroke Lead	64 (mm)
	(No lead screw)

(Unit: mm/s)

Stroke List

Stroke (mm)	Standard Price
64	-

② Cable List

Type	Cable Symbol	Standard Price
Standard Type (Robot Cables)	P (1m)	-
	S (3m)	-
	M (5m)	-
Special Lengths	X06 (6m) ~ X10 (10m)	-
	X11 (11m) ~ X15 (15m)	-
	X16 (16m) ~ X20 (20m)	-
		-

* The RCL comes standard with a robot cable.

* See page A-39 for cables for maintenance.

Actuator Specifications

Item	Description
Drive System	Linear servo motor
Encoder Resolution	0.042mm
Base	Material: Aluminum (white alumite treated)
Allowable Dynamic Moment (Note)	Ma: 1.22N-m Mb: 1.08N-m Mc: 0.34N-m
Overhang Load Length	Ma direction: 120mm or less Mb, Mc direction: 80mm or less
Ambient Operating Temp./Humidity	0~40°C, 85% RH or less (non-condensing)

(Note) Based on a 5,000km service life.

377 RCL-SA3L

- Slider Type
- Mini
- Standard
- Controllers Integrated
- Rod Type
- Mini
- Standard
- Controllers Integrated
- Table/Arm/Flat Type
- Mini
- Standard
- Gripper/Rotary Type
- Linear Servo Type
- Cleanroom Proof
- Splash Proof
- Controllers
- PMEC/AMEC
- PSEP/ASEP
- ROBO NET
- ERC2
- PCON
- ACON
- SCON
- PSEL
- ASEL
- SSEL
- XSEL
- Pulse Motor
- Servo Motor (24V)
- Servo Motor (200V)
- Linear Servo Motor

Dimensions

For Special Orders P. A-9

- *1 The motor-encoder cable is connected here. See page A-39 for details on cables.
- *2 When homing, the slider moves to the mechanical end; therefore, please watch for any interference with the surrounding objects.

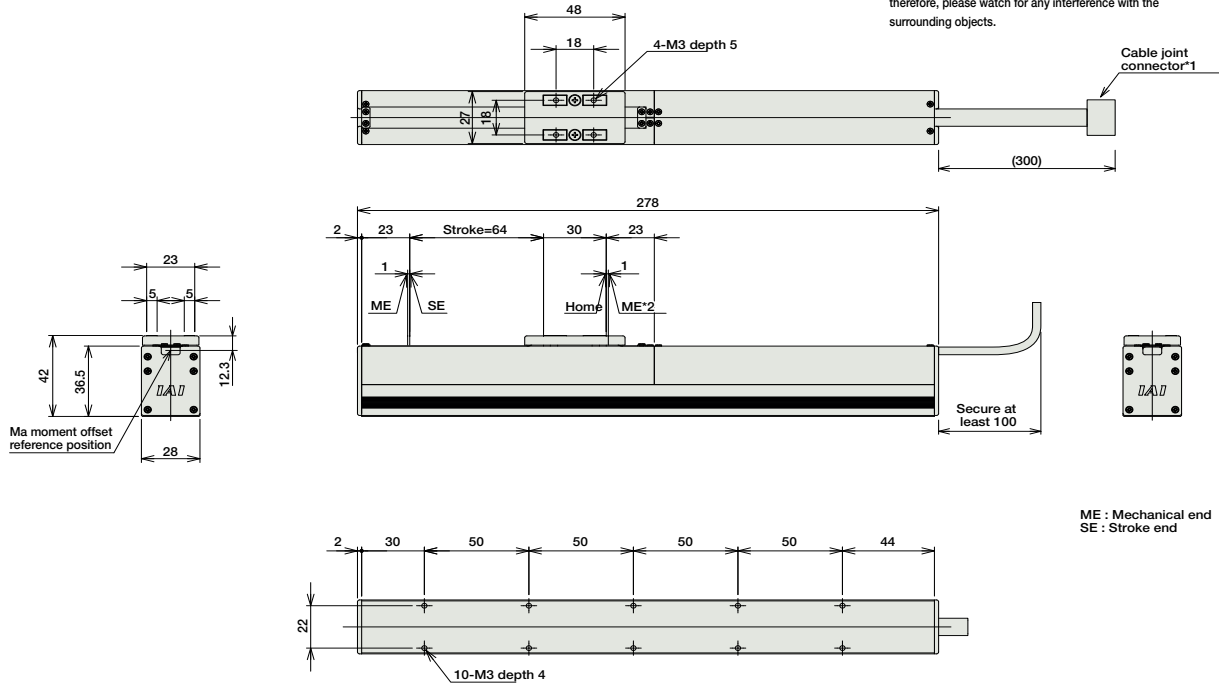

■ Dimensions and Weight by Stroke

Stroke	64
Weight (kg)	0.82

① Compatible Controllers

The RCL series actuators can operate with the controllers below. Select the controller according to your usage.

Name	External View	Model	Description	Max. Positioning Points	Input Voltage	Power Supply Capacity	Standard Price	See Page
Solenoid Valve Type		AMEC-C-10I-NP-2-1	Easy-to-use controller, even for beginners	3 points	AC100V	2.4A rated	-	→ P477
		ASEP-C-10I-NP-2-0	Operable with same signal as solenoid valve. Supports both single and double solenoid types. No homing necessary with simple absolute type.				-	→ P487
Splash-Proof Solenoid Valve Type		ASEP-CW-10I-NP-2-0					-	
Positioner Type		ACON-C-10I-NP-2-0	Positioning is possible for up to 512 points	512 points	DC24V	6.4A max.	-	→ P535
Safety-Compliant Positioner Type		ACON-CG-10I-NP-2-0					-	
Pulse Train Input Type (Differential Line Driver)		ACON-PL-10I-NP-2-0	Pulse train input type with differential line driver support	(-)	DC24V	6.4A max.	-	→ P535
Pulse Train Input Type (Open Collector)		ACON-PO-10I-NP-2-0	Pulse train input type with open collector support				-	
Serial Communication Type		ACON-SE-10I-N-0-0	Dedicated to serial communication	64 points			-	
Field Network Type		RACON-10	Dedicated to field network	768 points			-	→ P503
Program Control Type		ASEL-C-1-10I-NP-2-0	Programmed operation is possible. Operation is possible on up to 2 axes	1500 points			-	→ P567

* This is for the single-axis ASEL.

IAI

RCL-SA3L **378**

- Slider Type
- Mini
- Standard
- Controllers Integrated
- Rod Type
- Mini
- Standard
- Controllers Integrated
- Table/Arm /Flat Type
- Mini
- Standard
- Gripper/ Rotary Type
- Linear Servo Type
- Cleanroom Proof
- Splash Proof
- Controllers
- PMEC /AMEC
- PSEP /ASEP
- ROBO NET
- ERC2
- PCON
- ACON
- SCON
- PSEL
- ASEL
- SSEL
- XSEL
- Pulse Motor
- Servo Motor (24V)
- Servo Motor (200V)
- Linear Servo Motor

Dimensions

For Special Orders P. A-9

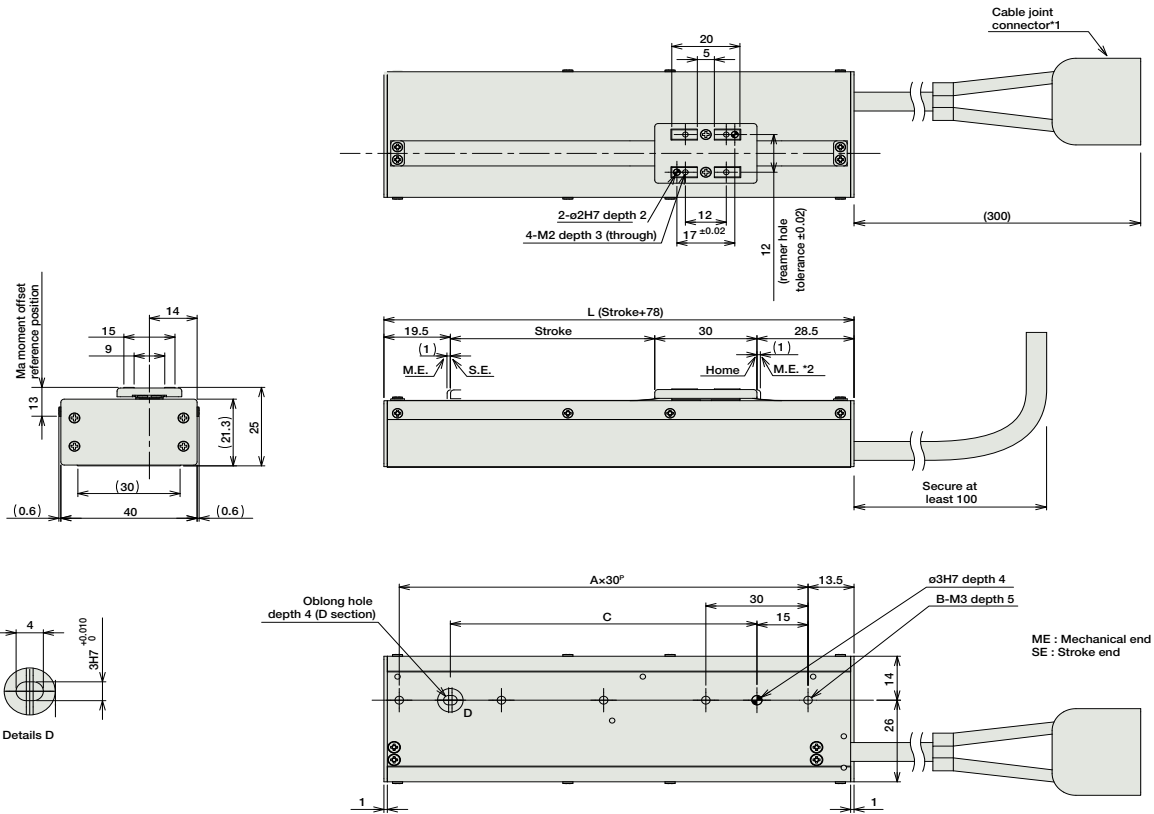

- *1 The motor-encoder cable is connected here. See page A-39 for details on cables.
- *2 When homing, the slider moves to the mechanical end; therefore, please watch for any interference with the surrounding objects.

■ Dimensions and Weight by Stroke

Stroke	30	60	90	120	150	180
L	108	138	168	198	228	258
A	3	4	5	6	7	8
B	4	5	6	7	8	9
C	60	90	120	150	180	210
Weight (kg)	0.21	0.25	0.29	0.32	0.36	0.4

② Compatible controller

The RCL series actuators can operate with the controllers below. Select the controller according to your usage.

Name	External View	Model	Description	Max. Positioning Points	Input Voltage	Power Supply Capacity	Standard Price	See Page
Solenoid Valve Type		AMEC-C-2I-NP-2-1	Easy-to-use controller, even for beginners	3 points	AC100V	2.4A rated	-	→ P477
		ASEP-C-2I-NP-2-0	Operable with same signal as solenoid valve. Supports both single and double solenoid types. No homing necessary with simple absolute type.					
Splash-Proof Solenoid Valve Type		ASEP-CW-2I-NP-2-0						→ P487
Positioner Type		ACON-C-2I-NP-2-0	Positioning is possible for up to 512 points	512 points	DC24V	4.6A max.	-	→ P535
Safety-Compliant Positioner Type		ACON-CG-2I-NP-2-0						
Pulse Train Input Type (Differential Line Driver)		ACON-PL-2I-NP-2-0	Pulse train input type with differential line driver support	(-)	DC24V	4.6A max.	-	→ P535
Pulse Train Input Type (Open Collector)		ACON-PO-2I-NP-2-0	Pulse train input type with open collector support					
Serial Communication Type		ACON-SE-2I-N-0-0	Dedicated to serial communication	64 points				
Field Network Type		RACON-2	Dedicated to field network	768 points				→ P503
Program Control Type		ASEL-C-1-2I-NP-2-0	Programmed operation is possible. Operation is possible on up to 2 axes	1500 points				→ P567

* This is for the single-axis ASEL.

- Slider Type
- Mini
- Standard
- Controllers Integrated
- Rod Type
- Mini
- Standard
- Controllers Integrated
- Table/Arm /Flat Type
- Mini
- Standard
- Gripper/ Rotary Type
- Linear Servo Type
- Cleanroom Proof
- Splash Proof
- Controllers
- PMEC /AMEC
- PSEP /ASEP
- ROBO NET
- ERC2
- PCON
- ACON
- SCON
- PSEL
- ASEL
- SSEL
- XSEL
- Pulse Motor
- Servo Motor (24V)
- Servo Motor (200V)
- Linear Servo Motor

Dimensions

For Special Orders P. A-9

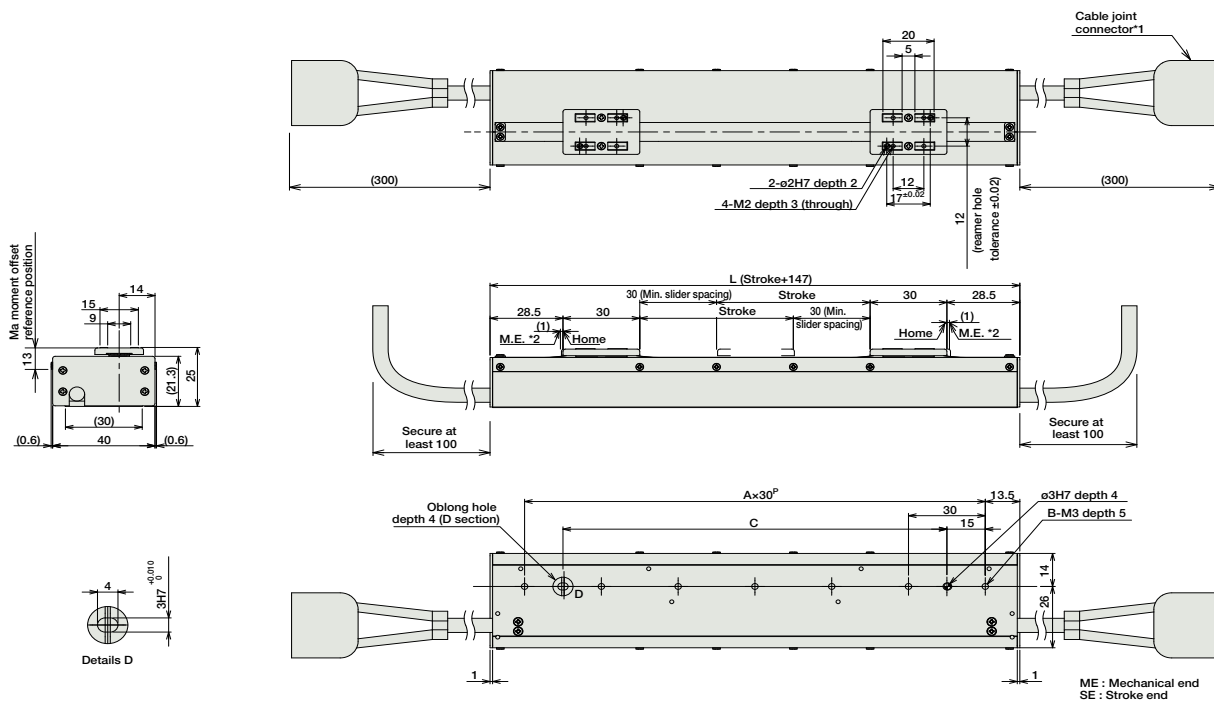

- *1 The motor-encoder cable is connected here. See page A-39 for details on cables.
- *2 When homing, the slider moves to the mechanical end; therefore, please watch for any interference with the surrounding objects.

Note:
A controller is required for each slider.
(or, one unit of 2-axis controller is required.)

■ Dimensions and Weight by Stroke

Stroke	30	60	90	120
L	177	207	237	267
A	5	6	7	8
B	6	7	8	9
C	120	150	180	210
Weight (kg)	0.37	0.4	0.44	0.48

② Compatible controller

The RCL series actuators can operate with the controllers below. Select the controller according to your usage.

Name	External View	Model	Description	Max. Positioning Points	Input Voltage	Power Supply Capacity	Standard Price	See Page
Solenoid Valve Type		AMEC-C-2I-NP-2-1	Easy-to-use controller, even for beginners	3 points	AC100V	2.4A rated	-	→ P477
		ASEP-C-2I-NP-2-0	Operable with same signal as solenoid valve. Supports both single and double solenoid types. No homing necessary with simple absolute type.					→ P487
Splash-Proof Solenoid Valve Type		ASEP-CW-2I-NP-2-0						
Positioner Type		ACON-C-2I-NP-2-0	Positioning is possible for up to 512 points	512 points	DC24V	4.6A max.	-	→ P535
Safety-Compliant Positioner Type		ACON-CG-2I-NP-2-0						
Pulse Train Input Type (Differential Line Driver)		ACON-PL-2I-NP-2-0	Pulse train input type with differential line driver support	(-)				
Pulse Train Input Type (Open Collector)		ACON-PO-2I-NP-2-0	Pulse train input type with open collector support					
Serial Communication Type		ACON-SE-2I-N-0-0	Dedicated to serial communication	64 points				
Field Network Type		RACON-2	Dedicated to field network	768 points				→ P503
Program Control Type		ASEL-C-1-2I-NP-2-0	Programmed operation is possible. Operation is possible on up to 2 axes	1500 points				→ P567

* This is for the single-axis ASEL.

- Slider Type
- Mini
- Standard
- Controllers Integrated
- Rod Type
- Mini
- Standard
- Controllers Integrated
- Table/Arm /Flat Type
- Mini
- Standard
- Gripper/ Rotary Type
- Linear Servo Type
- Cleanroom Proof
- Splash Proof
- Controllers
- PMEC /AMEC
- PSEP /ASEP
- ROBO NET
- ERC2
- PCON
- ACON
- SCON
- PSEL
- ASEL
- SSEL
- XSEL
- Pulse Motor
- Servo Motor (24V)
- Servo Motor (200V)
- Linear Servo Motor

Dimensions

For Special Orders P. A-9

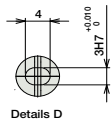
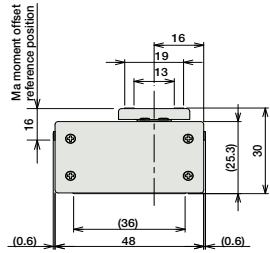
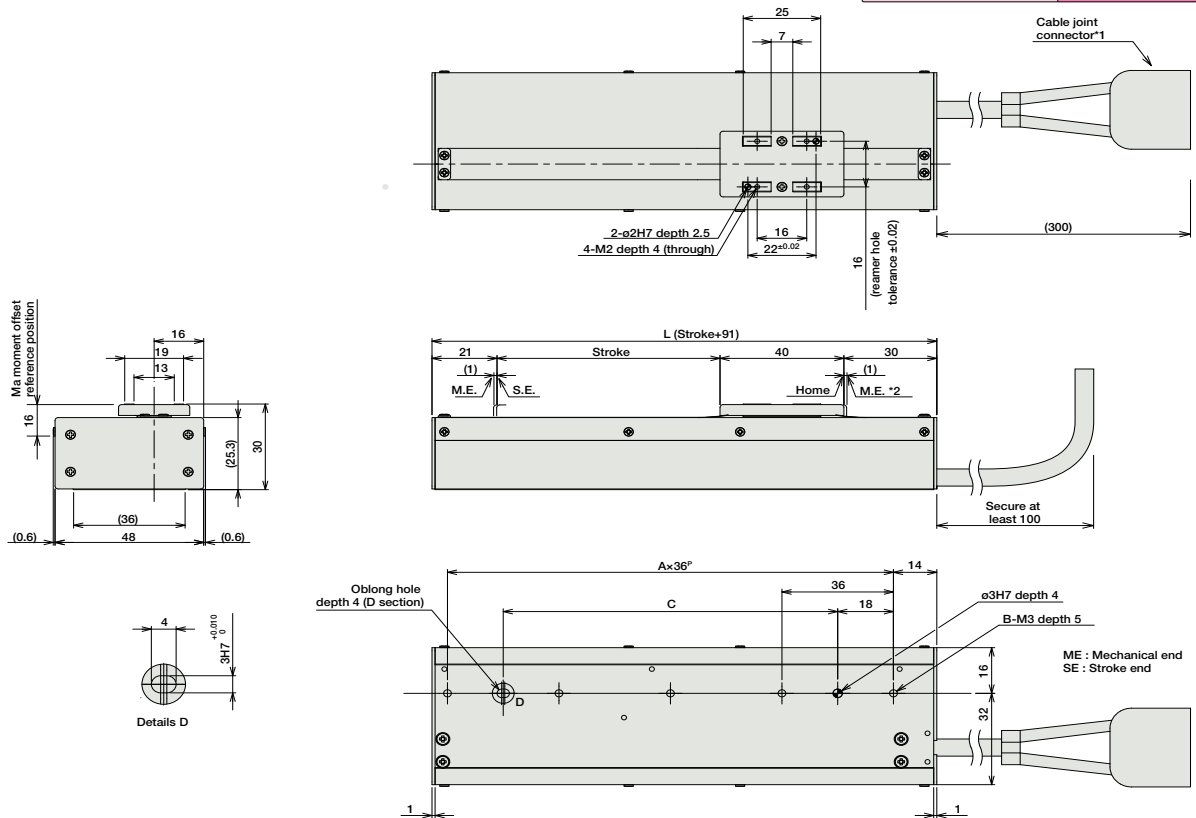

- *1 The motor-encoder cable is connected here. See page A-39 for details on cables.
- *2 When homing, the slider moves to the mechanical end; therefore, please watch for any interference with the surrounding objects.

■ Dimensions and Weight by Stroke

Stroke	36	72	108	144	180	216
L	127	163	199	235	271	307
A	3	4	5	6	7	8
B	4	5	6	7	8	9
C	72	108	144	180	216	252
Weight (kg)	0.35	0.42	0.48	0.55	0.62	0.68

② Compatible controller

The RCL series actuators can operate with the controllers below. Select the controller according to your usage.

Name	External View	Model	Description	Max. Positioning Points	Input Voltage	Power Supply Capacity	Standard Price	See Page
Solenoid Valve Type		AMEC-C-5I-NP-2-1	Easy-to-use controller, even for beginners	3 points	AC100V	2.4A rated	-	→ P477
Splash-Proof Solenoid Valve Type		ASEP-C-5I-NP-2-0	Operable with same signal as solenoid valve. Supports both single and double solenoid types. No homing necessary with simple absolute type.					→ P487
Positioner Type		ACON-C-5I-NP-2-0	Positioning is possible for up to 512 points	512 points	DC24V	6.4A max.	-	→ P535
Safety-Compliant Positioner Type		ACON-CG-5I-NP-2-0						
Pulse Train Input Type (Differential Line Driver)		ACON-PL-5I-NP-2-0	Pulse train input type with differential line driver support	(-)	DC24V	6.4A max.	-	→ P535
Pulse Train Input Type (Open Collector)		ACON-PO-5I-NP-2-0	Pulse train input type with open collector support					
Serial Communication Type		ACON-SE-5I-N-0-0	Dedicated to serial communication	64 points	DC24V	6.4A max.	-	→ P503
Field Network Type		RACON-5	Dedicated to field network	768 points				
Program Control Type		ASEL-C-1-5I-NP-2-0	Programmed operation is possible. Operation is possible on up to 2 axes	1500 points	DC24V	6.4A max.	-	→ P567

* This is for the single-axis ASEL.

- Slider Type
- Mini
- Standard
- Controllers Integrated
- Rod Type
- Mini
- Standard
- Controllers Integrated
- Table/Arm /Flat Type
- Mini
- Standard
- Gripper/ Rotary Type
- Linear Servo Type
- Cleanroom Proof
- Splash Proof
- Controllers
- PMEC /AMEC
- PSEP /ASEP
- ROBO NET
- ERC2
- PCON
- ACON
- SCON
- PSEL
- ASEL
- SSEL
- XSEL
- Pulse Motor
- Servo Motor (24V)
- Servo Motor (200V)
- Linear Servo Motor

Dimensions

For Special Orders P. A-9

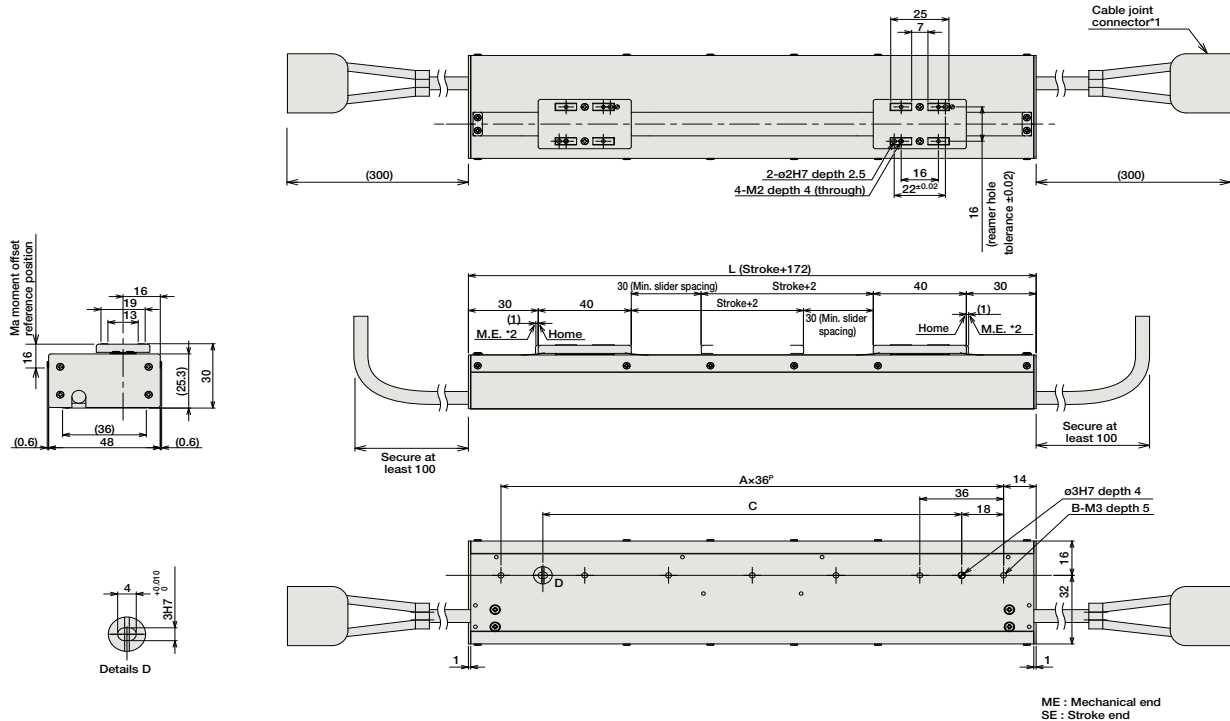

- *1 The motor-encoder cable is connected here. See page A-39 for details on cables.
- *2 When homing, the slider moves to the mechanical end; therefore, please watch for any interference with the surrounding objects.

Note:
A controller is required for each slider.
(or, one unit of 2-axis controller is required.)

■ Dimensions and Weight by Stroke

Stroke	36	72	108	144
L	208	244	280	316
A	5	6	7	8
B	6	7	8	9
C	144	180	216	252
Weight (kg)	0.62	0.69	0.75	0.82

② Compatible controller

The RCL series actuators can operate with the controllers below. Select the controller according to your usage.

Name	External View	Model	Description	Max. Positioning Points	Input Voltage	Power Supply Capacity	Standard Price	See Page
Solenoid Valve Type		AMEC-C-5I-NP-2-1	Easy-to-use controller, even for beginners	3 points	AC100V	2.4A rated	-	→ P477
		ASEP-C-5I-NP-2-0	Operable with same signal as solenoid valve. Supports both single and double solenoid types. No homing necessary with simple absolute type.				-	→ P487
Splash-Proof Solenoid Valve Type		ASEP-CW-5I-NP-2-0					-	
Positioner Type		ACON-C-5I-NP-2-0	Positioning is possible for up to 512 points	512 points	DC24V	6.4A max.	-	→ P535
Safety-Compliant Positioner Type		ACON-CG-5I-NP-2-0						
Pulse Train Input Type (Differential Line Driver)		ACON-PL-5I-NP-2-0	Pulse train input type with differential line driver support	(-)	DC24V	6.4A max.	-	→ P535
Pulse Train Input Type (Open Collector)		ACON-PO-5I-NP-2-0	Pulse train input type with open collector support					
Serial Communication Type		ACON-SE-5I-N-0-0	Dedicated to serial communication	64 points			-	
Field Network Type		RACON-5	Dedicated to field network	768 points			-	→ P503
Program Control Type		ASEL-C-1-5I-NP-2-0	Programmed operation is possible. Operation is possible on up to 2 axes	1500 points			-	→ P567

* This is for the single-axis ASEL.

- Slider Type
- Mini
- Standard
- Controllers Integrated
- Rod Type
- Mini
- Standard
- Controllers Integrated
- Table/Arm /Flat Type
- Mini
- Standard
- Gripper/ Rotary Type
- Linear Servo Type
- Cleanroom Proof
- Splash Proof
- Controllers
- PMEC /AMEC
- PSEP /ASEP
- ROBO NET
- ERC2
- PCON
- ACON
- SCON
- PSEL
- ASEL
- SSEL
- XSEL
- Pulse Motor
- Servo Motor (24V)
- Servo Motor (200V)
- Linear Servo Motor

Dimensions

For Special Orders P. A-9

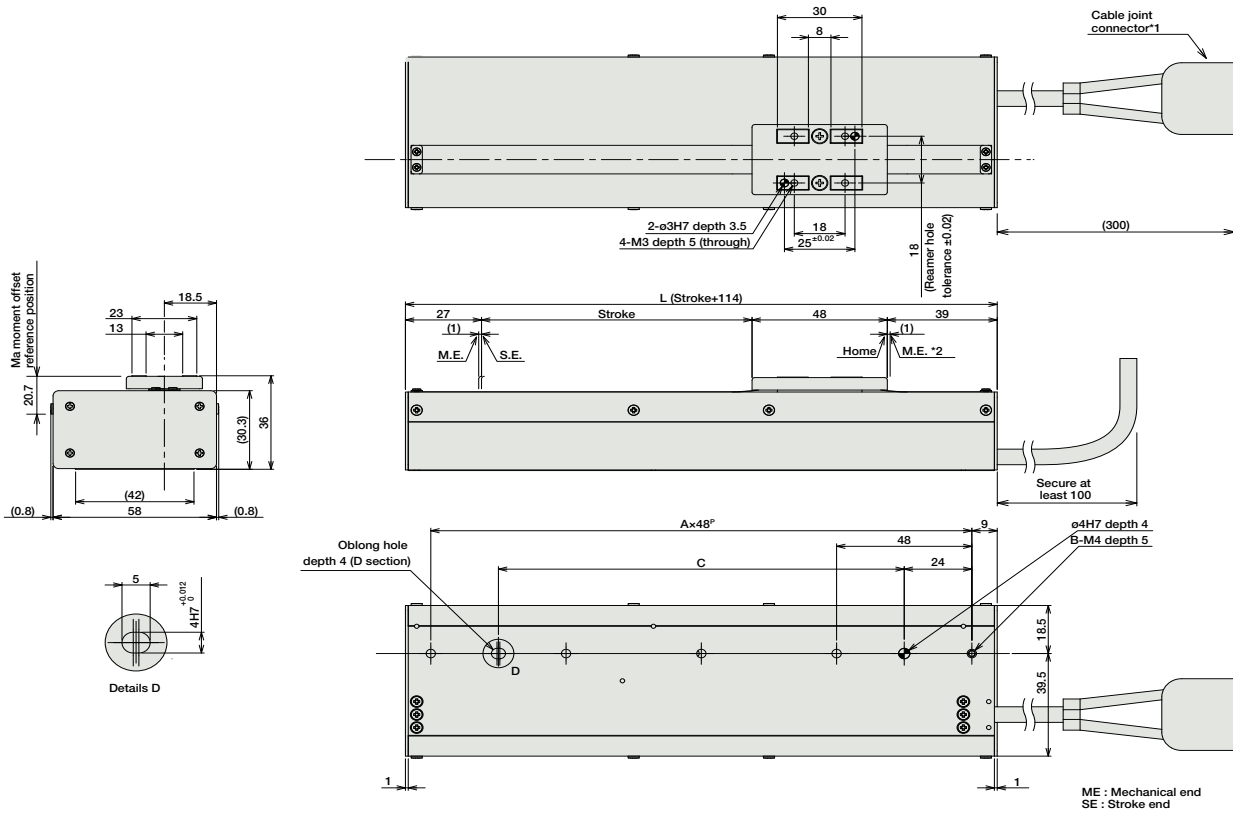

- *1 The motor-encoder cable is connected here. See page A-39 for details on cables.
- *2 When homing, the slider moves to the mechanical end; therefore, please watch for any interference with the surrounding objects.

■ Dimensions and Weight by Stroke

Stroke	48	96	144	192	240	288
L	162	210	258	306	354	402
A	3	4	5	6	7	8
B	4	5	6	7	8	9
C	96	144	192	240	288	336
Weight (kg)	0.67	0.8	0.93	1.07	1.2	1.34

② Compatible controller

The RCL series actuators can operate with the controllers below. Select the controller according to your usage.

Name	External View	Model	Description	Max. Positioning Points	Input Voltage	Power Supply Capacity	Standard Price	See Page
Solenoid Valve Type		AMEC-C-10I-NP-2-1	Easy-to-use controller, even for beginners	3 points	AC100V	2.4A rated	-	→ P477
		ASEP-C-10I-NP-2-0	Operable with same signal as solenoid valve. Supports both single and double solenoid types. No homing necessary with simple absolute type.					→ P487
Splash-Proof Solenoid Valve Type		ASEP-CW-10I-NP-2-0						
Positioner Type		ACON-C-10I-NP-2-0	Positioning is possible for up to 512 points	512 points				
Safety-Compliant Positioner Type		ACON-CG-10I-NP-2-0						
Pulse Train Input Type (Differential Line Driver)		ACON-PL-10I-NP-2-0	Pulse train input type with differential line driver support	(-)	DC24V	6.4A max.		→ P535
Pulse Train Input Type (Open Collector)		ACON-PO-10I-NP-2-0	Pulse train input type with open collector support					
Serial Communication Type		ACON-SE-10I-N-0-0	Dedicated to serial communication	64 points				
Field Network Type		RACON-10	Dedicated to field network	768 points				→ P503
Program Control Type		ASEL-C-1-10I-NP-2-0	Programmed operation is possible. Operation is possible on up to 2 axes	1500 points				→ P567

* This is for the single-axis ASEL.

- Slider Type
- Mini
- Standard
- Controllers Integrated
- Rod Type
- Mini
- Standard
- Controllers Integrated
- Table/Arm /Flat Type
- Mini
- Standard
- Gripper/ Rotary Type
- Linear Servo Type
- Cleanroom Proof
- Splash Proof
- Controllers
- PMEC /AMEC
- PSEP /ASEP
- ROBO NET
- ERC2
- PCON
- ACON
- SCON
- PSEL
- ASEL
- SSEL
- XSEL
- Pulse Motor
- Servo Motor (24V)
- Servo Motor (200V)
- Linear Servo Motor

RCL-SM6L

ROBO Cylinder Slider Type Mini Multi-Slider Type 58mm Width Linear Servo Motor

■ Configuration: **RCL** — **SM6L** — **I** — **10** — **N** — — —
 Series — Type — Encoder — Motor — Lead — Stroke — Compatible Controllers — Cable Length
 I: Incremental 10: 10W linear servo motor N: No screw 48: 48mm \ 192:192mm (48mm pitch increments)
 A1: ACON RACON ASEL A3: AMEC ASEP N: None P: 1m S: 3m M: 5m X : Custom

* See page Pre-35 for an explanation of the naming convention.

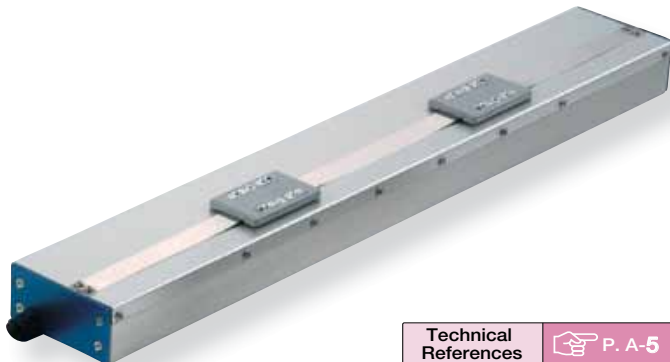

Technical References P. A-5

- POINT** Notes on Selection
- Please note that this type has magnetic flux leakage. (If magnetism is a problem, please use SA1L, SA2L, or SA3L)
 - The load capacity is determined by the acceleration and the duty. Check the load capacity on the Load Capacity (Horizontal) vs. Acceleration graph on the right. The duty is $\frac{\text{Operating time}}{\text{Operating time} + \text{stationary time}} \times 100$ per cycle.
 - The mounting orientation is horizontal only. When operated vertically, please use caution, as the slider will fall when the power is turned OFF.
 - Please note that an absolute unit cannot be used.

Load Capacity (Horizontal) vs. Acceleration

Max. Acceleration (G)	Load Capacity (kg)	
	Continuous Operation (100% duty)	
0.1	3.2	
0.3		
0.5	2	
1	1	
1.5	0.65	
2	0.5	

Actuator Specifications

Lead and Load Capacity

Model	Motor Output (W)	Max. Load Capacity		Rated Thrust (N)	Max. Momentary Thrust (N)	Max. Acceleration (G)	Positioning Repeatability (mm)	Stroke (mm)
		Horizontal (kg)	Vertical (kg)					
RCL-SM6L-I-10-N-①-②-③	10	See table above	-	10	30	2	±0.1	48~192 (48mm increments)

Legend: ① Stroke ② Compatible controller ③ Cable length

Stroke and Maximum Speed

Lead	Stroke	48 ~ 192 (48mm increments)
	(No lead screw)	1600

(Unit: mm/s)

① Stroke List

Stroke (mm)	Standard Price
48	-
96	-
144	-
192	-

③ Cable List

Type	Cable Symbol	Standard Price
Standard Type (Robot Cables)	P (1m)	-
	S (3m)	-
	M (5m)	-
Special Lengths	X06 (6m) ~ X10 (10m)	-
	X11 (11m) ~ X15 (15m)	-
	X16 (16m) ~ X20 (20m)	-
		-

* The RCL comes standard with a robot cable.

* See page A-39 for cables for maintenance.

Actuator Specifications

Item	Description
Drive System	Linear servo motor
Encoder Resolution	0.042mm
Base	Material: Aluminum (white alumite treated)
Allowable Dynamic Moment (Note)	Ma: 0.87N-m Mb: 0.75N-m Mc: 1.22N-m
Overhang Load Length	Ma direction: 80mm or less Mb-Mc direction: 120mm or less
Ambient Operating Temp./Humidity	0~40°C, 85% RH or less (non-condensing)

(Note) Based on a 5,000km service life.

389

RCL-SM6L

- Slider Type
- Mini
- Standard
- Controllers Integrated
- Rod Type
- Mini
- Standard
- Controllers Integrated
- Table/Arm/Flat Type
- Mini
- Standard
- Gripper/Rotary Type
- Linear Servo Type
- Cleanroom Proof
- Splash Proof
- Controllers
- PMEC/AMEC
- PSEP/ASEP
- ROBO NET
- ERC2
- PCON
- ACON
- SCON
- PSEL
- ASEL
- SSEL
- XSEL
- Pulse Motor
- Servo Motor (24V)
- Servo Motor (200V)
- Linear Servo Motor

Dimensions

For Special Orders P. A-9

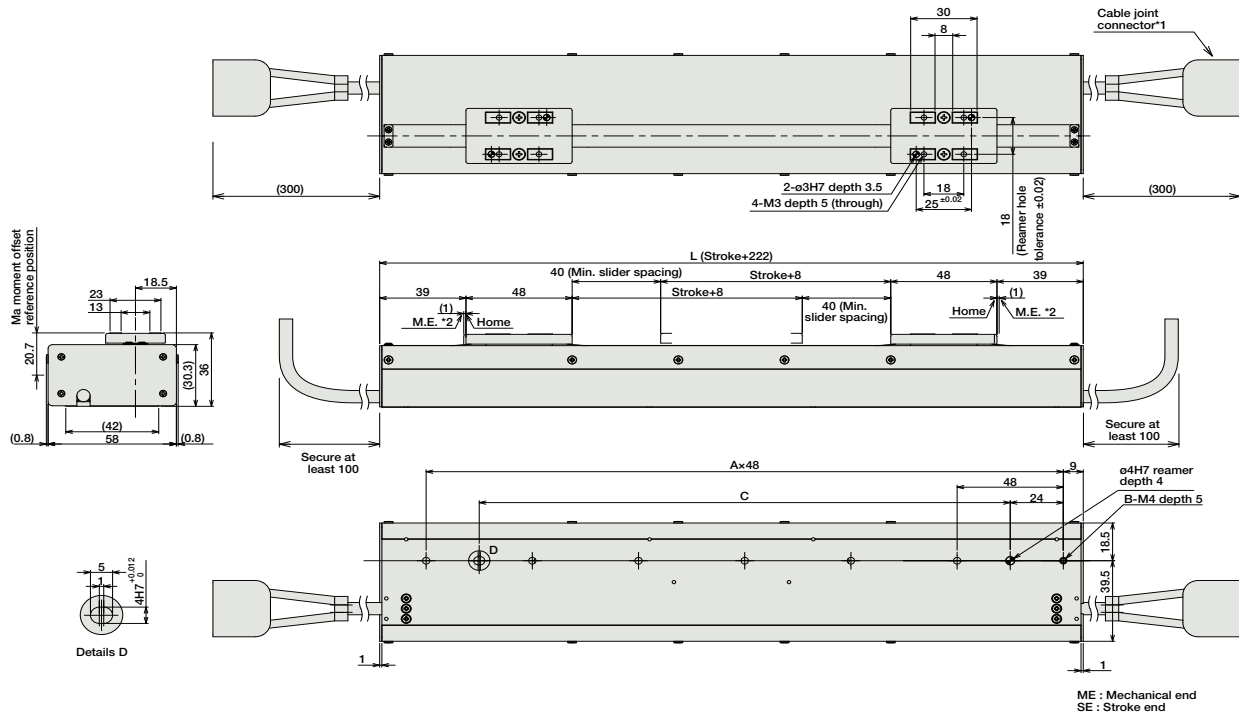

- *1 The motor-encoder cable is connected here. See page A-39 for details on cables.
- *2 When homing, the slider moves to the mechanical end; therefore, please watch for any interference with the surrounding objects.

Note:
A controller is required for each slider.
(or, one unit of 2-axis controller is required.)

■ Dimensions and Weight by Stroke

Stroke	48	96	144	192
L	270	318	366	414
A	5	6	7	8
B	6	7	8	9
C	192	240	288	336
Weight (kg)	1.17	1.31	1.44	1.58

② Compatible controller

The RCL series actuators can operate with the controllers below. Select the controller according to your usage.

Name	External View	Model	Description	Max. Positioning Points	Input Voltage	Power Supply Capacity	Standard Price	See Page
Solenoid Valve Type		AMEC-C-10I-NP-2-1	Easy-to-use controller, even for beginners	3 points	AC100V	2.4A rated	-	→ P477
		ASEP-C-10I-NP-2-0	Operable with same signal as solenoid valve. Supports both single and double solenoid types.					
Splash-Proof Solenoid Valve Type		ASEP-CW-10I-NP-2-0	No homing necessary with simple absolute type.					→ P487
Positioner Type		ACON-C-10I-NP-2-0	Positioning is possible for up to 512 points	512 points	DC24V	6.4A max.	-	→ P535
Safety-Compliant Positioner Type		ACON-CG-10I-NP-2-0						
Pulse Train Input Type (Differential Line Driver)		ACON-PL-10I-NP-2-0	Pulse train input type with differential line driver support	(-)				
Pulse Train Input Type (Open Collector)		ACON-PO-10I-NP-2-0	Pulse train input type with open collector support					
Serial Communication Type		ACON-SE-10I-N-0-0	Dedicated to serial communication	64 points				
Field Network Type		RACON-10	Dedicated to field network	768 points				→ P503
Program Control Type		ASEL-C-1-10I-NP-2-0	Programmed operation is possible. Operation is possible on up to 2 axes	1500 points				→ P567

* This is for the single-axis ASEL.

- Slider Type
- Mini
- Standard
- Controllers Integrated
- Rod Type
- Mini
- Standard
- Controllers Integrated
- Table/Arm /Flat Type
- Mini
- Standard
- Gripper/ Rotary Type
- Linear Servo Type
- Cleanroom Proof
- Splash Proof
- Controllers
- PMEC /AMEC
- PSEP /ASEP
- ROBO NET
- ERC2
- PCON
- ACON
- SCON
- PSEL
- ASEL
- SSEL
- XSEL
- Pulse Motor
- Servo Motor (24V)
- Servo Motor (200V)
- Linear Servo Motor

RCL-RA1L

ROBO Cylinder Rod Type Mini-Slim Type ø16mm Diameter Linear Servo Motor

■ Configuration: **RCL** — **RA1L** — **I** — **2** — **N** — **25** — — —

Series — Type — Encoder — Motor — Lead — Stroke — Compatible Controllers — Cable Length — Option

I: Incremental 2: 2W linear servo motor N: No screw 25: 25mm

A1: ACON RACON ASEL A3: AMEC ASEP N: None P: 1m S: 3m M: 5m X : Custom B: Brake (with brake box) BN: Brake (without brake box)

* See page Pre-35 for an explanation of the naming convention.

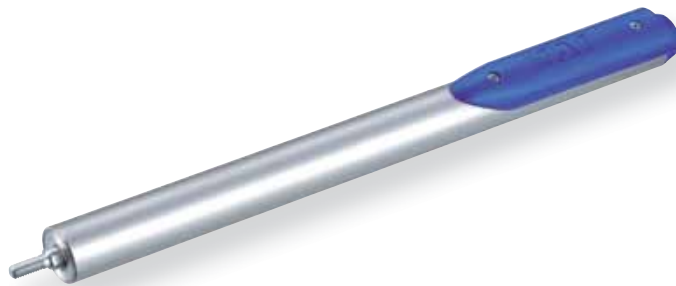

Technical References P. A-5

POINT Notes on Selection

- The load capacity is determined by the acceleration and the duty. Check the load capacity on the Load Capacity (Horizontal) vs. Acceleration graph on the right.
The duty is $\frac{\text{Operating time}}{\text{Operating time} + \text{stationary time}} \times 100$ per cycle.
- If you will be operating the actuator vertically, please use the optional brake.
- Please use an external guide to avoid horizontal or rotational load on the rod.
- The pushing force will fluctuate significantly at low electrical limits.
- Please note that an absolute unit cannot be used.

Load Capacity (Horizontal) vs. Acceleration

Max. Acceleration (G)	Load Capacity (kg)			
	Continuous Operation (100% duty)		(70% or less duty)	
	Horizontal	Vertical	Horizontal	Vertical
0.1	0.5	0.1	0.5	0.1
0.3				
0.5	0.42		0.25	
1	0.2			
1.5	0.11	-	0.15	-
2	0.07	-	0.1	-

Pushing Force Guideline

The pushing motion is possible within the values below. (N)

Electrical Limit	30%	40%	50%	60%	70%	80%
Pushing Force	0.75	1	1.25	1.5	1.75	2

(Note) The above pushing force is applicable to horizontal usage. For vertical upward motions, subtract 0.5N from the above value, and for downward motions, add 0.5N.

Actuator Specifications

Lead and Load Capacity

Model	Motor Output (W)	Max. Load Capacity		Rated Thrust (N)	Max. Momentary Thrust (N)	Max. Acceleration (G)	Positioning Repeatability (mm)	Stroke (mm)
		Horizontal (kg)	Vertical (kg)					
RCL-RA1L-I-2-N-25-①-②-③	2	See table above	See table above	2.5	10	Horizontal 2G Vertical 1G	±0.1	25 (Fixed)

Legend ① Compatible controller ② Cable length ③ Options

Stroke and Maximum Speed

Stroke / Lead	25 (mm)	
	No Brake	With Break
(No lead screw)	300	

(Unit: mm/s)

Stroke List

Stroke (mm)	Standard Price
25	-

② Cable List

Type	Cable Symbol	Standard Price	
		No Brake	With Break
Standard Type (Robot Cables)	P (1m)	-	-
	S (3m)	-	-
	M (5m)	-	-
Special Lengths	X06 (6m) ~ X10 (10m)	-	-
	X11 (11m) ~ X15 (15m)	-	-
	X16 (16m) ~ X20 (20m)	-	-
		-	-

* The RCL comes standard with a robot cable.
* See page A-39 for cables for the brake-less model.
* See page 392 for cables for the brake-equipped model.

③ Option Price List

Name	Option Code	See Page	Standard Price
Brake (with brake box)	B	→ P392	-
Brake (without brake box)	BN	→ P392	-

* To use the brake, a brake box and a dedicated cable for the brake-equipped model are required. If you just need the brake-equipped actuator itself for maintenance, please specify option "BN" (no brake box).

Actuator Specifications

Item	Description
Drive System	Linear servo motor
Encoder Resolution	0.042mm
Base	Material: Carbon steel tube (nickel-plated)
Ambient Operating Temp./Humidity	0~40°C, 85% RH or less (non-condensing)
Service Life	10 million round trip cycles

391

RCL-RA1L

- Slider Type
- Mini
- Standard
- Controllers Integrated
- Rod Type
- Mini
- Standard
- Controllers Integrated
- Table/Arm /Flat Type
- Mini
- Standard
- Gripper/ Rotary Type
- Linear Servo Type
- Cleanroom Proof
- Splash Proof
- Controllers
- PMEC /AMEC
- PSEP /ASEP
- ROBO NET
- ERC2
- PCON
- ACON
- SCON
- PSEL
- ASEL
- SSEL
- XSEL
- Pulse Motor
- Servo Motor (24V)
- Servo Motor (200V)
- Linear Servo Motor

Dimensions

For Special Orders P. A-9

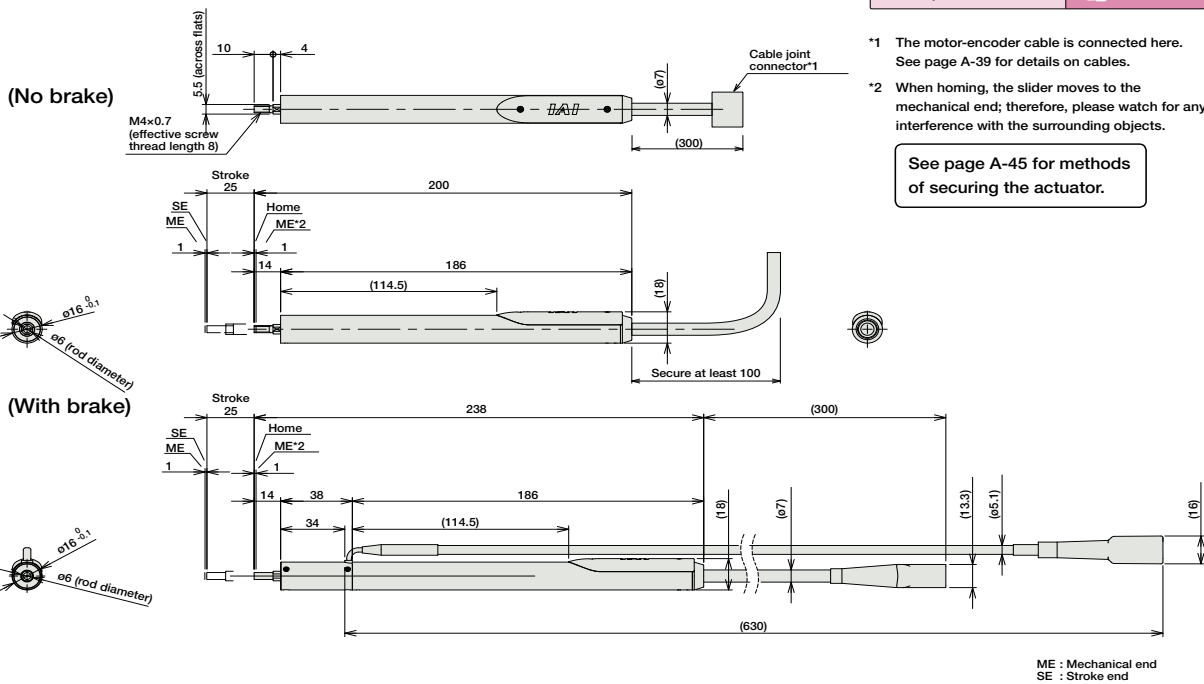

- *1 The motor-encoder cable is connected here. See page A-39 for details on cables.
- *2 When homing, the slider moves to the mechanical end; therefore, please watch for any interference with the surrounding objects.

See page A-45 for methods of securing the actuator.

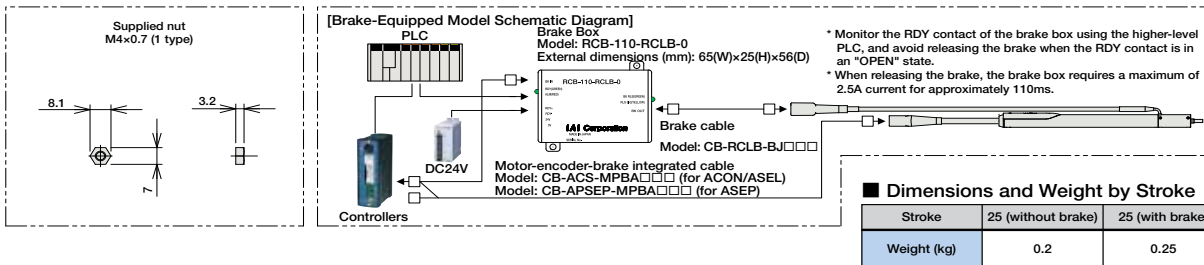

① Compatible Controllers

The RCL series actuators can operate with the controllers below. Select the controller according to your usage.

Name	External View	Model	Description	Max. Positioning Points	Input Voltage	Power Supply Capacity	Standard Price	See Page
Solenoid Valve Type		AMEC-C-2I-NP-2-1	Easy-to-use controller, even for beginners	3 points	AC100V	2.4A rated	-	→ P477
		ASEP-C-2I-NP-2-0	Operable with same signal as solenoid valve. Supports both single and double solenoid types. No homing necessary with simple absolute type.				-	→ P487
Splash-Proof Solenoid Valve Type		ASEP-CW-2I-NP-2-0					-	
Positioner Type		ACON-C-2I-NP-2-0	Positioning is possible for up to 512 points	512 points	DC24V	4.6A max.	-	→ P535
Safety-Compliant Positioner Type		ACON-CG-2I-NP-2-0						
Pulse Train Input Type (Differential Line Driver)		ACON-PL-2I-NP-2-0	Pulse train input type with differential line driver support	(-)	DC24V	4.6A max.	-	→ P535
Pulse Train Input Type (Open Collector)		ACON-PO-2I-NP-2-0	Pulse train input type with open collector support					
Serial Communication Type		ACON-SE-2I-N-0-0	Dedicated to serial communication	64 points			-	
Field Network Type		RACON-2	Dedicated to field network	768 points			-	→ P503
Program Control Type		ASEL-C-1-2I-NP-2-0	Programmed operation is possible. Operation is possible on up to 2 axes	1500 points			-	→ P567

* This is for the single-axis ASEL.



RCL-RA1L **392**

Sold & Serviced By:

Toll Free Phone (877) SERV098
 Toll Free Fax (877) SERV099
 www.electromate.com
 sales@electromate.com

- Slider Type
- Mini
- Standard
- Controllers Integrated
- Rod Type
- Mini
- Standard
- Controllers Integrated
- Table/Arm /Flat Type
- Mini
- Standard
- Controllers Integrated
- Table/Arm /Flat Type
- Mini
- Standard
- Gripper/ Rotary Type
- Linear Servo Type
- Cleanroom Proof
- Splash Proof
- Controllers
- PMEC /AMEC
- PSEP /ASEP
- ROBO NET
- ERC2
- PCON
- ACON
- SCON
- PSEL
- ASEL
- SSEL
- XSEL
- Pulse Motor
- Servo Motor (24V)
- Servo Motor (200V)
- Linear Servo Motor

RCL-RA2L

ROBO Cylinder Rod Type Mini-Slim Type ø20mm Diameter Linear Servo Motor

■ Configuration: **RCL** — **RA2L** — **I** — **5** — **N** — **30** — — —

Series — Type — Encoder — Motor — Lead — Stroke — Compatible Controllers — Cable Length — Option

I: Incremental 5: 5W linear servo motor N: No screw 30: 30mm

A1: ACON N: None B: Brake (with brake box)
 RACON P: 1m BN: Brake (without brake box)
 ASEL S: 3m
 A3: AMEC M: 5m
 ASEP X : Custom

* See page Pre-35 for an explanation of the naming convention.

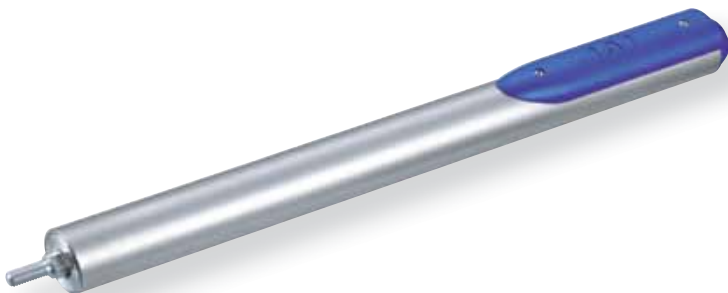

Technical References P. A-5

POINT Notes on Selection

- The load capacity is determined by the acceleration and the duty. Check the load capacity on the Load Capacity (Horizontal) vs. Acceleration graph on the right. The duty is $\frac{\text{Operating time}}{\text{Operating time} + \text{stationary time}} \times 100$ per cycle.
- If you will be operating the actuator vertically, please use the optional brake.
- Please use an external guide to avoid horizontal or rotational load on the rod.
- The pushing force will fluctuate significantly at low electrical limits.
- Please note that an absolute unit cannot be used.

Load Capacity (Horizontal) vs. Acceleration

Max. Acceleration (G)	Load Capacity (kg)			
	Continuous Operation (100% duty)		(70% or less duty)	
	Horizontal	Vertical	Horizontal	Vertical
0.1	1	0.2	1	0.2
0.3				
0.5	0.85	0.4	0.5	-
1	0.24		0.3	
1.5	0.15	-	0.2	-

Pushing Force Guideline

The pushing motion is possible within the values below. (N)

Electrical Limit	30%	40%	50%	60%	70%	80%
Pushing Force	1.5	2	2.5	3	3.5	4

(Note) The above pushing force is applicable to horizontal usage. For vertical upward motions, subtract 1N from the above value, and for downward motions, add 1N.

Actuator Specifications

Lead and Load Capacity

Model	Motor Output (W)	Max. Load Capacity		Rated Thrust (N)	Max. Momentary Thrust (N)	Max. Acceleration (G)	Positioning Repeatability (mm)	Stroke (mm)
		Horizontal (kg)	Vertical (kg)					
RCL-RA2L-I-5-N-30-①-②-③	5	See table above	See table above	5	18	Horizontal 2G Vertical 1G	±0.1	30 (Fixed)

Legend ① Compatible controller ② Cable length ③ Options

Stroke and Maximum Speed

Stroke / Lead	30 (mm)
	(No lead screw)

(Unit: mm/s)

Stroke List

Stroke (mm)	Standard Price
30	-

② Cable List

Type	Cable Symbol	Standard Price	
		No Brake	With Break
Standard Type (Robot Cables)	P (1m)	-	-
	S (3m)	-	-
	M (5m)	-	-
Special Lengths	X06 (6m) ~ X10 (10m)	-	-
	X11 (11m) ~ X15 (15m)	-	-
	X16 (16m) ~ X20 (20m)	-	-
		-	-

* The RCL comes standard with a robot cable.
 * See page A-39 for cables for the brake-less model.
 * See page 394 for cables for the brake-equipped model.

③ Option Price List

Name	Option Code	See Page	Standard Price
Brake (with brake box)	B	→ P394	-
Brake (without brake box)	BN	→ P394	-

* To use the brake, a brake box and a dedicated cable for the brake-equipped model are required. If you just need the brake-equipped actuator itself for maintenance, please specify option "BN" (no brake box).

Actuator Specifications

Item	Description
Drive System	Linear servo motor
Encoder Resolution	0.042mm
Base	Material: Carbon steel tube (nickel-plated)
Ambient Operating Temp./Humidity	0~40°C, 85% RH or less (non-condensing)
Service Life	10 million round trip cycles

393

RCL-RA2L

- Slider Type
- Mini
- Standard
- Controllers Integrated
- Rod Type
- Mini
- Standard
- Controllers Integrated
- Table/Arm /Flat Type
- Mini
- Standard
- Gripper/ Rotary Type
- Linear Servo Type
- Cleanroom Proof
- Splash Proof
- Controllers
- PMEC /AMEC
- PSEP /ASEP
- ROBO NET
- ERC2
- PCON
- ACON
- SCON
- PSEL
- ASEL
- SSEL
- XSEL
- Pulse Motor
- Servo Motor (24V)
- Servo Motor (200V)
- Linear Servo Motor

Dimensions

For Special Orders P. A-9

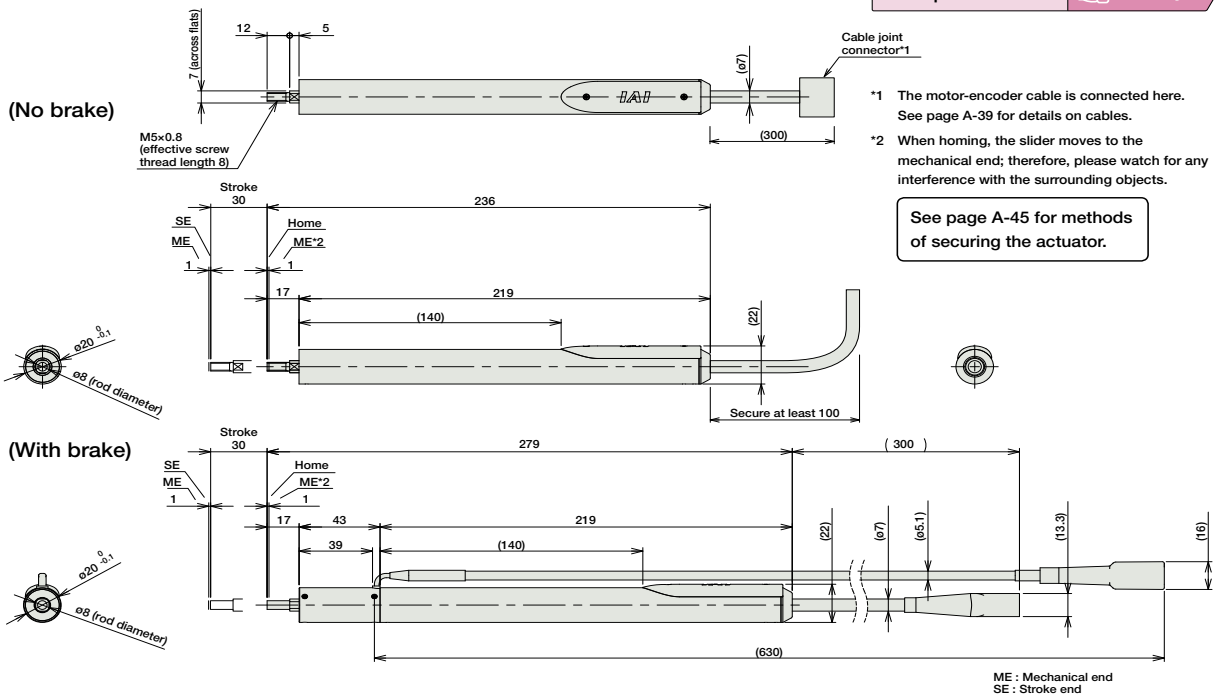

- *1 The motor-encoder cable is connected here. See page A-39 for details on cables.
- *2 When homing, the slider moves to the mechanical end; therefore, please watch for any interference with the surrounding objects.

See page A-45 for methods of securing the actuator.

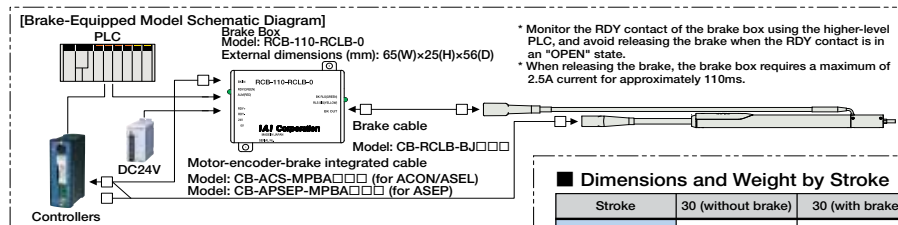
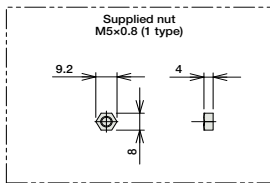

■ Dimensions and Weight by Stroke

Stroke	30 (without brake)	30 (with brake)
Weight (kg)	0.33	0.4

① Compatible Controllers

The RCL series actuators can operate with the controllers below. Select the controller according to your usage.

Name	External View	Model	Description	Max. Positioning Points	Input Voltage	Power Supply Capacity	Standard Price	See Page
Solenoid Valve Type		AMEC-C-5I-NP-2-1	Easy-to-use controller, even for beginners	3 points	AC100V	2.4A rated	-	→ P477
		ASEP-C-5I-NP-2-0	Operable with same signal as solenoid valve. Supports both single and double solenoid types. No homing necessary with simple absolute type.				-	→ P487
Splash-Proof Solenoid Valve Type		ASEP-CW-5I-NP-2-0					-	
Positioner Type		ACON-C-5I-NP-2-0	Positioning is possible for up to 512 points	512 points	DC24V	6.4A max.	-	→ P535
Safety-Compliant Positioner Type		ACON-CG-5I-NP-2-0					-	
Pulse Train Input Type (Differential Line Driver)		ACON-PL-5I-NP-2-0	Pulse train input type with differential line driver support	(-)	DC24V	6.4A max.	-	→ P535
Pulse Train Input Type (Open Collector)		ACON-PO-5I-NP-2-0	Pulse train input type with open collector support				-	
Serial Communication Type		ACON-SE-5I-N-0-0	Dedicated to serial communication	64 points			-	
Field Network Type		RACON-5	Dedicated to field network	768 points			-	→ P503
Program Control Type		ASEL-C-1-5I-NP-2-0	Programmed operation is possible. Operation is possible on up to 2 axes	1500 points			-	→ P567

* This is for the single-axis ASEL.

- Slider Type
- Mini
- Standard
- Controllers Integrated
- Rod Type
- Mini
- Standard
- Controllers Integrated
- Table/Arm /Flat Type
- Mini
- Standard
- Gripper/ Rotary Type
- Linear Servo Type
- Cleanroom Proof
- Splash Proof
- Controllers
- PMEC /AMEC
- PSEP /ASEP
- ROBO NET
- ERC2
- PCON
- ACON
- SCON
- PSEL
- ASEL
- SSEL
- XSEL
- Pulse Motor
- Servo Motor (24V)
- Servo Motor (200V)
- Linear Servo Motor

RCL-RA3L

ROBO Cylinder Rod Type Mini-Slim Type ø25mm Diameter Linear Servo Motor

■ Configuration: **RCL** — **RA3L** — **I** — **10** — **N** — **40** — — —

Series — Type — Encoder — Motor — Lead — Stroke — Compatible Controllers — Cable Length — Option

I: Incremental 10: 10W linear servo motor N: No screw 40: 40mm

A1: ACON N: None B: Brake (with brake box)
 RACON P: 1m BN: Brake (without brake box)
 ASEL S: 3m
 A3: AMEC M: 5m
 ASEP X : Custom

* See page Pre-35 for an explanation of the naming convention.

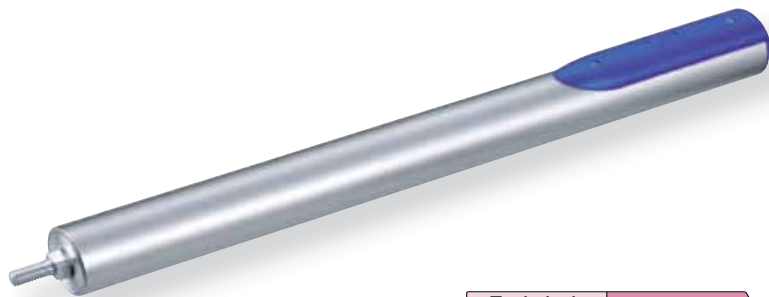

Technical References P. A-5

POINT Notes on Selection

- The load capacity is determined by the acceleration and the duty. Check the load capacity on the Load Capacity (Horizontal) vs. Acceleration graph on the right. The duty is $\frac{\text{Operating time}}{\text{Operating time} + \text{stationary time}} \times 100$ per cycle.
- If you will be operating the actuator vertically, please use the optional brake.
- Please use an external guide to avoid horizontal or rotational load on the rod.
- The pushing force will fluctuate significantly at low electrical limits.
- Please note that an absolute unit cannot be used.

Load Capacity (Horizontal) vs. Acceleration

Max. Acceleration (G)	Load Capacity (kg)			
	Continuous Operation (100% duty)		(70% or less duty)	
	Horizontal	Vertical	Horizontal	Vertical
0.1	2	0.4	2	0.4
0.3				
0.5	1.6		1	
1	0.78			
1.5	0.46	-	0.6	-
2	0.3	-	0.4	-

Pushing Force Guideline

The pushing motion is possible within the values below. (N)

Electrical Limit	30%	40%	50%	60%	70%	80%
Pushing Force	3	4	5	6	7	8

(Note) The above pushing force is applicable to horizontal usage. For vertical upward motions, subtract 1.8N from the above value, and for downward motions, add 1.8N.

Actuator Specifications

Lead and Load Capacity

Model	Motor Output (W)	Max. Load Capacity		Rated Thrust (N)	Max. Momentary Thrust (N)	Max. Acceleration (G)	Positioning Repeatability (mm)	Stroke (mm)
		Horizontal (kg)	Vertical (kg)					
RCL-RA3L-I-10-N-40-①-②-③	10	See table above	See table above	10	30	Horizontal 2G Vertical 1G	±0.1	40 (Fixed)

Legend ① Compatible controller ② Cable length ③ Options

Stroke and Maximum Speed

Stroke / Lead	40 (mm)	
	No Brake	With Break
(No lead screw)	450	

(Unit: mm/s)

Stroke List

Stroke (mm)	Standard Price
40	-

② Cable List

Type	Cable Symbol	Standard Price	
		No Brake	With Break
Standard Type (Robot Cables)	P (1m)	-	-
	S (3m)	-	-
	M (5m)	-	-
Special Lengths	X06 (6m) ~ X10 (10m)	-	-
	X11 (11m) ~ X15 (15m)	-	-
	X16 (16m) ~ X20 (20m)	-	-
		-	-

* The RCL comes standard with a robot cable.
 * See page A-39 for cables for the brake-less model.
 * See page 396 for cables for the brake-equipped model.

③ Option Price List

Name	Option Code	See Page	Standard Price
Brake (with brake box)	B	→ P396	-
Brake (without brake box)	BN	→ P396	-

* To use the brake, a brake box and a dedicated cable for the brake-equipped model are required. If you just need the brake-equipped actuator itself for maintenance, please specify option "BN" (no brake box).

Actuator Specifications

Item	Description
Drive System	Linear servo motor
Encoder Resolution	0.042mm
Base	Material: Carbon steel tube (nickel-plated)
Ambient Operating Temp./Humidity	0~40°C, 85% RH or less (non-condensing)
Service Life	10 million round trip cycles

395

RCL-RA3L

- Slider Type
- Mini
- Standard
- Controllers Integrated
- Rod Type
- Mini
- Standard
- Controllers Integrated
- Table/Arm /Flat Type
- Mini
- Standard
- Gripper/ Rotary Type
- Linear Servo Type
- Cleanroom Proof
- Splash Proof
- Controllers
- PMEC /AMEC
- PSEP /ASEP
- ROBO NET
- ERC2
- PCON
- ACON
- SCON
- PSEL
- ASEL
- SSEL
- XSEL
- Pulse Motor
- Servo Motor (24V)
- Servo Motor (200V)
- Linear Servo Motor

Dimensions

For Special Orders P. A-9

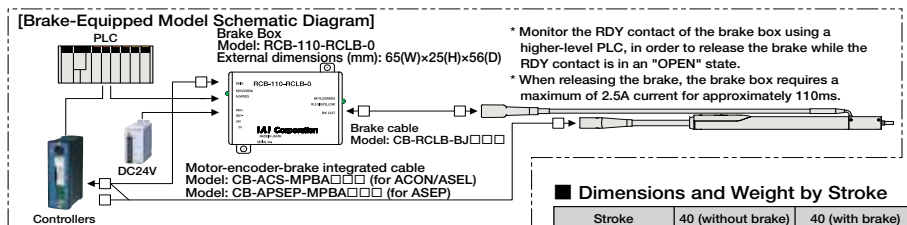
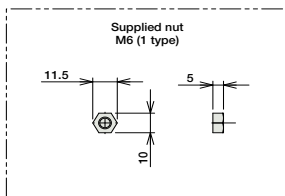
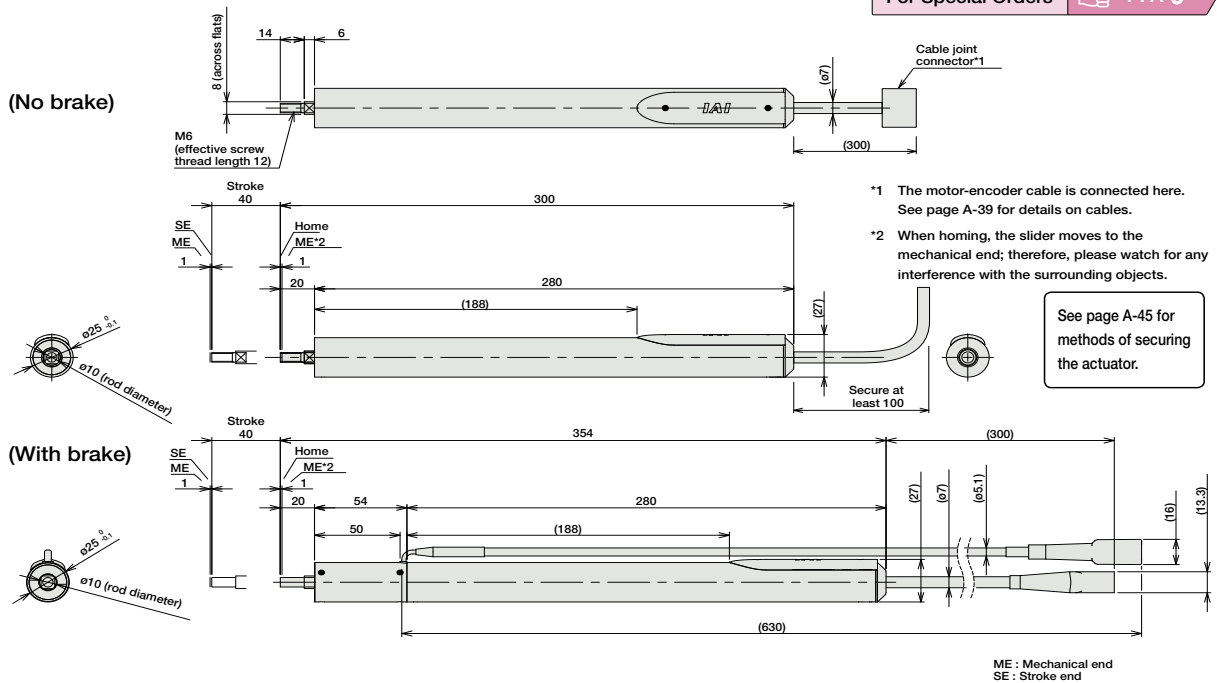

■ Dimensions and Weight by Stroke

Stroke	40 (without brake)	40 (with brake)
Weight (kg)	0.6	0.77

① Compatible Controllers

The RCL series actuators can operate with the controllers below. Select the controller according to your usage.

Name	External View	Model	Description	Max. Positioning Points	Input Voltage	Power Supply Capacity	Standard Price	See Page
Solenoid Valve Type		AMEC-C-10I-NP-2-1	Easy-to-use controller, even for beginners	3 points	AC100V	2.4A rated	-	→ P477
		ASEP-C-10I-NP-2-0	Operable with same signal as solenoid valve. Supports both single and double solenoid types. No homing necessary with simple absolute type.					→ P487
Splash-Proof Solenoid Valve Type		ASEP-CW-10I-NP-2-0						
Positioner Type		ACON-C-10I-NP-2-0	Positioning is possible for up to 512 points	512 points	DC24V	6.4A max.	-	→ P535
Safety-Compliant Positioner Type		ACON-CG-10I-NP-2-0						
Pulse Train Input Type (Differential Line Driver)		ACON-PL-10I-NP-2-0	Pulse train input type with differential line driver support	(-)	DC24V	6.4A max.	-	→ P535
Pulse Train Input Type (Open Collector)		ACON-PO-10I-NP-2-0	Pulse train input type with open collector support					
Serial Communication Type		ACON-SE-10I-N-0-0	Dedicated to serial communication	64 points				
Field Network Type		RACON-10	Dedicated to field network	768 points				→ P503
Program Control Type		ASEL-C-1-10I-NP-2-0	Programmed operation is possible. Operation is possible on up to 2 axes	1500 points				→ P567

* This is for the single-axis ASEL.

- Slider Type
- Mini
- Standard
- Controllers Integrated
- Rod Type
- Mini
- Standard
- Controllers Integrated
- Table/Arm /Flat Type
- Mini
- Standard
- Gripper/ Rotary Type
- Linear Servo Type
- Cleanroom Proof
- Splash Proof
- Controllers
- PMEC /AMEC
- PSEP /ASEP
- ROBO NET
- ERC2
- PCON
- ACON
- SCON
- PSEL
- ASEL
- SSEL
- XSEL
- Pulse Motor
- Servo Motor (24V)
- Servo Motor (200V)
- Linear Servo Motor