



Quality and Innovation

Super-Large SCARA Robot

IX-1000/1200



Sold & Serviced By:



Toll Free Phone (877) SERV098
Toll Free Fax (877) SERV099
www.electromate.com
sales@electromate.com

The latest addition to our offerings is the super-large SCARA series boasting an arm length of 1200 mm and payload of 50 kg, both of which are the largest among all our SCARA robots.



1 Wide range of operation and small footprint

The long arm extending 1200 mm allows the IX to carry work parts over a wide range of up to 2400 mm. The IX is also space-saving because its footprint is only one-eightieth that of a Cartesian robot having an equivalent range of operation.

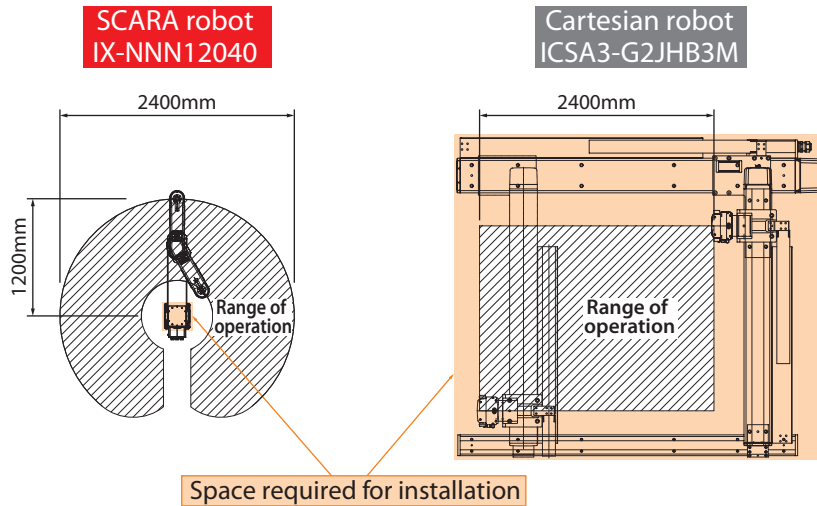

2 High-speed transfer

The IX demonstrates excellent high-speed performance backed by its maximum operating speed of 8308 mm/s. The IX can certainly help you reduce cycle times.

Time needed to move a 5-kg work part over a vertical distance of 100 mm and horizontal distance of 2400 mm.

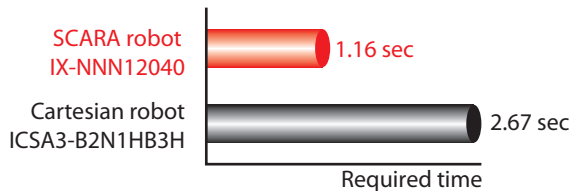

3 High payload

The IX can carry up to 50 kg, which is one of the highest payloads in its class. The IX is the perfect choice if your equipment must transfer heavy objects.

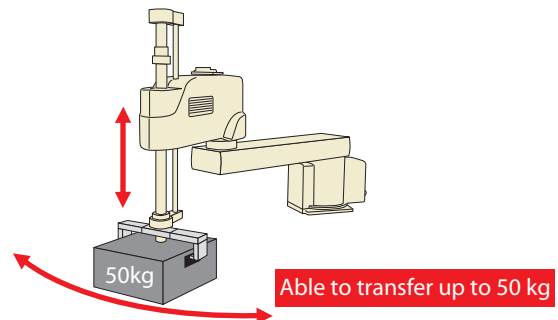

Model

<Robot>

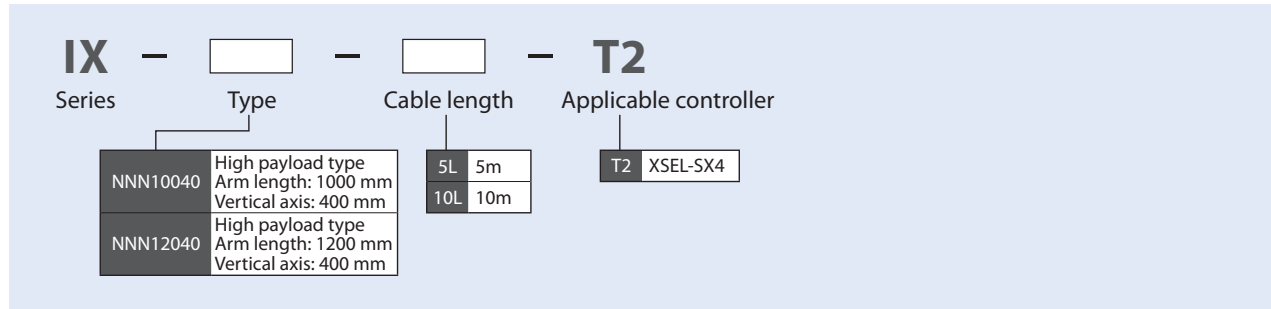

System Configuration

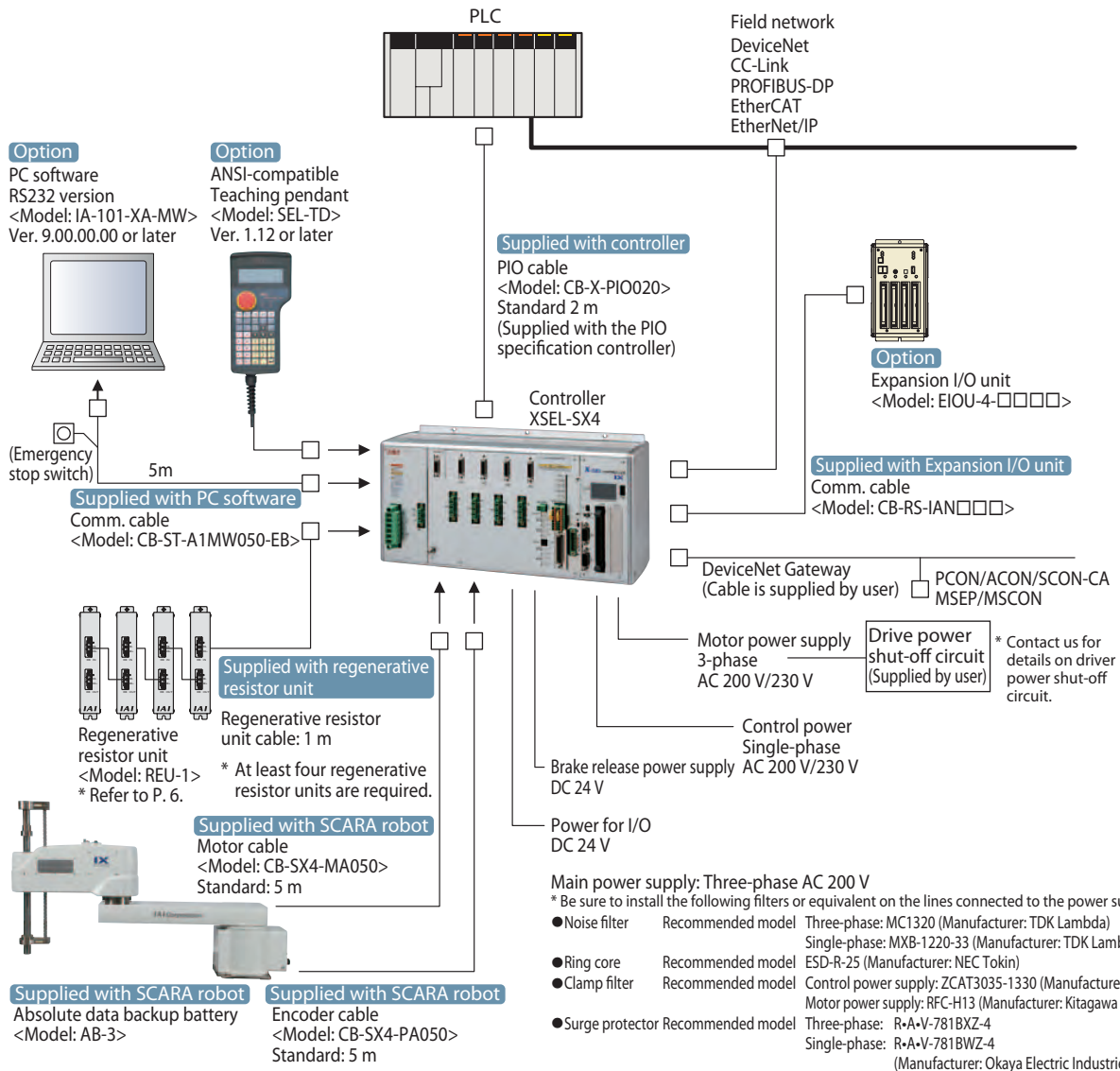

IX-NNN10040

Super-large SCARA Robot High-payload Type
Arm Length 1000 mm Vertical Axis 400 mm



Model Specification Items	IX Series	NNN10040 Type	Cable length	Applicable controller
		NNN10040 :High-payload type Arm length:1000 mm Vertical axis:400 mm	5L : 5m(standard) 10L: 10m	T2 :XSEL-SX4

* Refer to P. 2 for the details of model specification items.

Model/Specification

Model	Axis configuration	Arm length (mm)	Motor capacity (W)	Range of operation	Positioning repeatability (mm) (deg)	Maximum operating speed in PTP mode	Standard cycle times (sec) (Note 1)	Payload (kg) (Note 2)		Axis 3 (Note 3) push force thrust (N)		Axis 4 allowable load			
								Rated	Max.	Upper limit	Lower limit	Allowable moment of inertia (kg·m ²)	Allowable torque (N·m)		
IX-NNN10040-①-T2	Axis 1 Arm 1	500	1000	±140 deg	±0.040	7356 mm/s (synthesis rate)	0.59	20	50	—	—	0.5	20.0		
	Axis 2 Arm 2	500	600	±150 deg											
	Axis 3 Vertical axis	—	600	400 mm										±0.020	1000 mm/s
	Axis 4 Rotational axis	—	400	±360 deg										±0.010	1197.3 deg/s

* ① in the above model numbers indicates the cable length.

* SCARA robots cannot operate continuously at the 100% speed and acceleration. For the conditions in which they can operate, refer to "Reference for Operation Limits and Operation Settings" on the back cover.

Common Specifications

Encoder type	Absolute (Absolute data retention battery: Model AB-3)	Ambient temperature/humidity	Temperature: 0 to 40°C, Humidity: 20 to 85%RH or less (non-condensing)
User wiring	25-core AWG26 with shield + D-sub, 25-pin connector (socket)	Robot weight	93 kg
User piping	Outer diameter ø6, inner diameter ø4, air tube x 4 (Normal service pressure: 0.8 MPa)	Applicable controller	T2: XSEL-SX4 (dedicated controller)
Alarm indicator lamp	Red LED small indicator lamp x 1 (DC 24V must be supplied)	Cable length	5L: 5 m (standard) 10L: 10 m
Brake release switch	Brake release switch to prevent vertical axis from dropping (DC 24V must be supplied)		

Dimensional Drawings

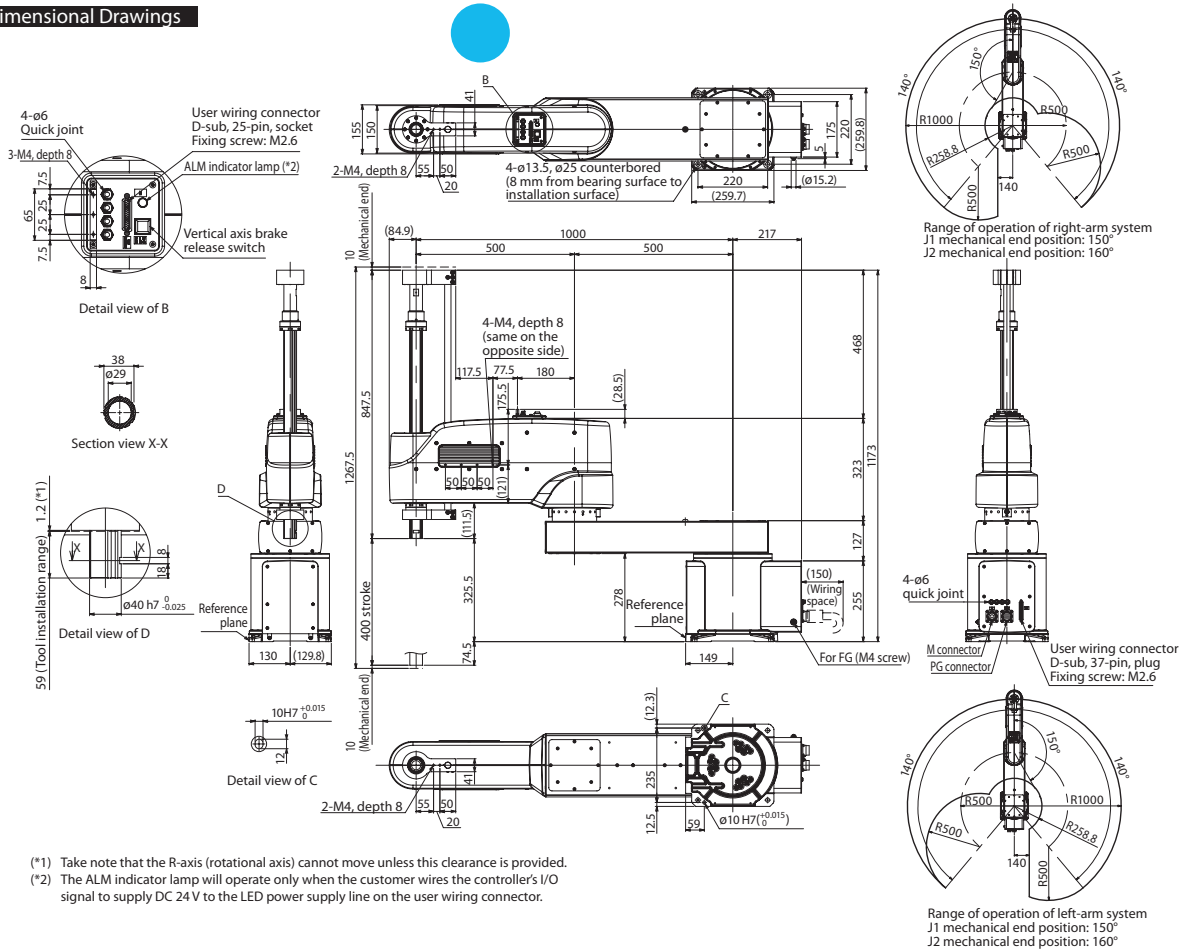

Applicable Controller Specification

Applicable controller	Feature	Maximum I/O points (input/output)	Power-supply voltage	Reference page
XSEL-SX4	Safety category 4 can be supported	192 points/192 points	3-phase, AC 200V	→P5

<p>Caution</p>	(Note 1) When 2 kg is transferred back and forth over a horizontal distance of 300 mm and vertical distance of 25 mm
	(Note 2) The rated payload represents the maximum mass carrying which the actuator can operate at its maximum speed and maximum acceleration. The maximum payload represents the maximum mass achievable at the greatest sacrifice of the speed and acceleration.
	(Note 3) This robot does not support push-motion operation.

IX-NNN12040 Super-large SCARA Robot, High-payload Type

Arm Length 1200 mm, Vertical Axis 400 mm



Model Specification Items	IX Series	NNN12040 Type	Cable length 5L : 5m(standard) 10L: 10m	T2 Applicable controller
		NNN12040 :High-payload type Arm length :1200 mm Vertical axis:400 mm		T2 :XSEL-SX4

* Refer to P.2 for the details of model specification items.

Model/Specification

Model	Axis configuration		Arm length (mm)	Motor capacity (W)	Range of operation	Positioning repeatability (mm) (deg)	Maximum operating speed in PTP mode	Standard cycle times (sec) (Note 1)	Payload (kg) (Note 2)		Axis 3 (Note 3) push force thrust (N)		Axis 4 allowable load	
	Axis 1	Axis 2							Rated	Max.	Upper limit	Lower limit	Allowable moment of inertia (kg·m ²)	Allowable torque (N·m)
IX-NNN12040-①-T2	Arm 1	Arm 2	700	1000	±140 deg	±0.050	8308 mm/s (synthesis rate)	0.66	20	50	—	—	0.5	20.0
	Axis 2	Axis 3	500	600	±150 deg									
	Axis 3	Vertical axis	—	600	400 mm	±0.020	1000 mm/s							
	Axis 4	Rotational axis	—	400	±360 deg	±0.010	1197.3 deg/s							

* ① in the above model numbers indicates the cable length.

* SCARA robots cannot operate continuously at the 100% speed and acceleration. For the conditions in which they can operate, refer to "Reference for Operation Limits and Operation Settings" on the back cover.

Common Specifications

Encoder type	Absolute (Absolute data retention battery: Model AB-3)
User wiring	25-core AWG26 with shield + D-sub, 25-pin connector (socket)
User piping	Outer diameter ø6, inner diameter ø4, air tube x 4 (Normal service pressure: 0.8 MPa)
Alarm indicator lamp	Red LED small indicator lamp x 1 (DC 24V must be supplied)
Brake release switch	Brake release switch to prevent vertical axis from dropping (DC 24V must be supplied)

Ambient temperature/humidity	Temperature: 0 to 40°C, Humidity: 20 to 85%RH or less (non-condensing)
Robot weight	97 kg
Applicable controller	T2: XSEL-SX4 (dedicated controller)
Cable length	5L: 5 m (standard) 10L: 10 m

Dimensional Drawings

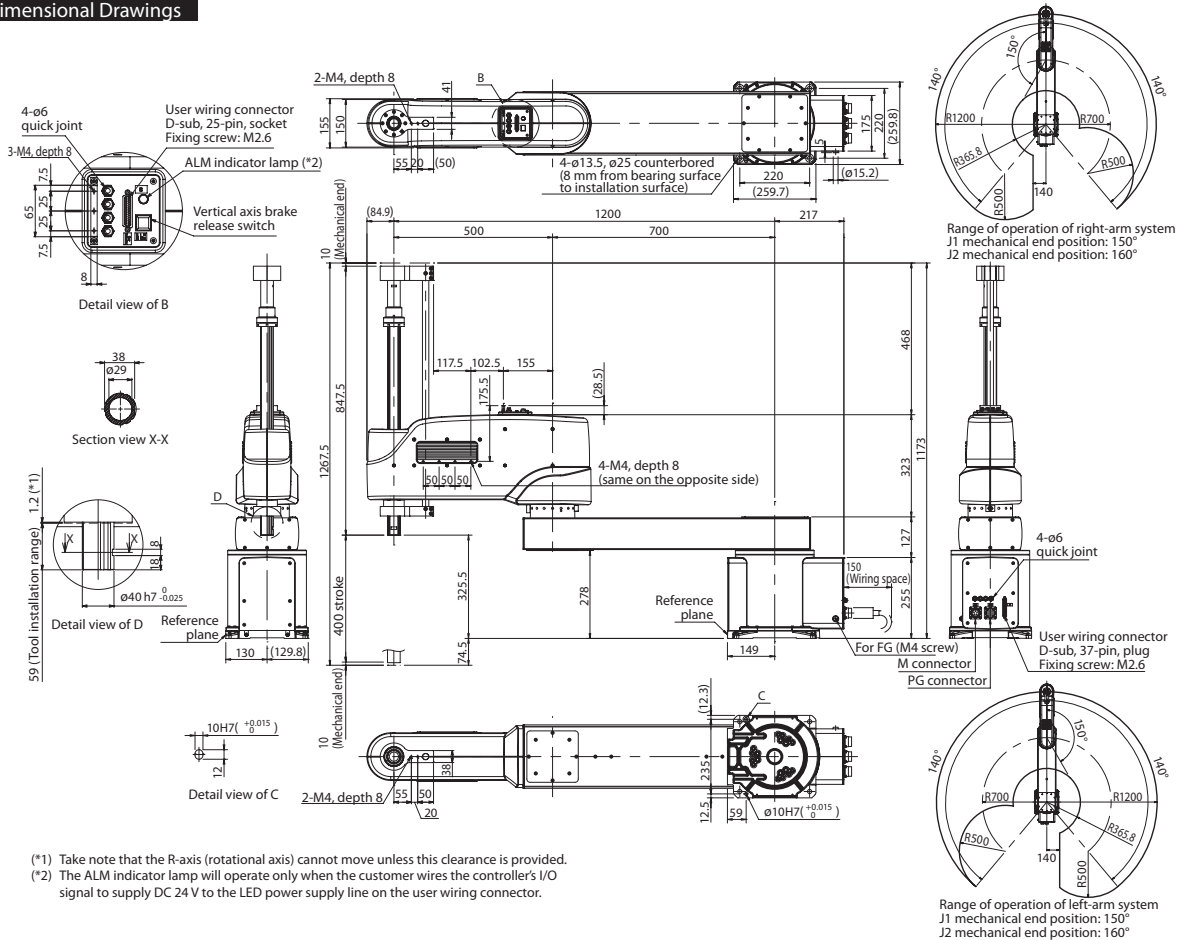

Applicable Controller Specification

Applicable controller	Feature	Maximum I/O points (input/output)	Power-supply voltage	Reference page
XSEL-SX4	Safety category 4 can be supported	192 points/192 points	3-phase, AC 200 V	→P5

<p>Caution</p>	(Note 1) When 2 kg is transferred back and forth over a horizontal distance of 300 mm and vertical distance of 25 mm
	(Note 2) The rated payload represents the maximum mass carrying which the actuator can operate at its maximum speed and maximum acceleration. The maximum payload represents the maximum mass achievable at the greatest sacrifice of the speed and acceleration.
	(Note 3) This robot does not support push-motion operation.

XSEL-SX4



**Super-large SCARA
Program Controller**

Model List

Type	SX4
Name	Super-large SCARA controller
External view	
Type	Global specification
Safety category (*1)	Category 4 can be supported
Number of programs	128 programs
Number of program steps	9999 steps
Number of positions	26666 positions
Power supply	3-phase AC 200 V

(*1) Meeting this safety category requires the customer to install a safety circuit externally to the controller.

Model

■ Dedicated Super-large SCARA Controller XSEL-SX4 Type

XSEL - SX4 - [] - [] [] [] - [] [] - [] - **3**

Series Type SCARA robot type Dedicated network slot (Slot 1) (Slot 2) (Slot 3) I/O slot (Slot 1) (Slot 2) I/O cable length Power/voltage

* For the details of options, refer to the XSEL-R/S controller catalog.

	E Not used IA IA net-compatible		E Not used DV DeviceNet CC CC-Link PR PROFIBUS-DP	E Not used N1 Input 32/Output 16 (NPN) N2 Input 16/Output 32 (NPN) N3 Input 48/Output 48 (NPN) P1 Input 32/Output 16 (PNP) P2 Input 16/Output 32 (PNP) P3 Input 48/Output 48 (PNP) DG DeviceNet Gateway master board	0 No cable 2 2 m (standard) 3 3m 5 5m
	E Not used EP EtherNet/IP EC EtherCAT				3 3-phase 200 V

NNN10040	Arm length 1000 mm/Z-axis 400 mm type
NNN12040	Arm length 1200 mm/Z-axis 400 mm type

(*1) Selectable boards are different and specified separately for dedicated network slots 1 to 3. For each slot, select one of the specified boards and enter the corresponding code.

(*2) One of the above I/O boards can be installed in both I/O slot 1 and slot 2, but the DG (DeviceNet Gateway board) option can only be installed in slot 1.

(*3) Both the dedicated network slots and I/O slots can be used at the same time.

Specification Table

Controller type	SX4 type
Control power-supply input	Single-phase AC 200/230 V \pm 10%
Motor power-supply input	Three-phase AC 200 to 230 V \pm 10%
Power supply capacity	10838 VA (The specific value varies depending on the I/O and network boards.)
Safety circuit configuration	Redundancy supported
Drive source breaker system	External safety circuit
Emergency stop input	B contact input (External power supply model, redundancy supported)
Enable input	B contact input (External power supply model, redundancy supported)
Number of programs	128 programs
Number of program steps	9999 steps (total)
Number of multi-tasking programs	16 programs
Number of positions	26,666 positions
Data memory device	Flash ROM + non-volatile RAM (FRAM): System battery (button battery) not required
Data input method	Teaching pendant (Model: SEL-TD) or PC software (Model: IA-101-XA-MW)
Standard input/output	2 boards can be installed, including a PIO board of 48 I/O points (NPN/PNP) and a PIO board of 96 I/O points (NPN/PNP)
Expansion input/output	None (A separate expansion I/O unit can be used to add up to 4 PIO boards.)
Serial communications function	Teaching port (D-sub 25 pins), 2-channel RS232C ports (D-sub 9 pins) Baud rate: 115.2 kbps max.
IA net	Number of connected units: 64 points / Baud rate: 12 Mbps, fixed
RC Gateway function	RS232C communication port (Channel 2 only) or DeviceNet Gateway master board port.
Fieldbus communication function	DeviceNet, CC-LINK, Profibus, EtherNet/IP, EtherCAT (One of EtherNet/IP and EtherCAT, and one of DeviceNet, CC-LINK and Profibus, can be supported at the same time.)
Clock function	Retention time: Approx. 10 days Charge time: Approx. 100 hours
Display unit	Optional panel unit (PU-1) can be connected.
Regenerative resistance	Built-in regenerative resistor of 1 k Ω /20 W 4 external regenerative resistor units must be connected.
Absolute battery	Built into the SCARA robot (Model: AB-3)
Protective function	Motor overcurrent, overload, motor driver temperature check, overload check, encoder open-circuit check, soft limit over, system error, absolute battery error, etc.
Ambient operating temp/humidity	0 to 40°C, 85%RH or less (non-condensing). Free from corrosive gases. In particular, there shall be no significant dust.

* Refer to the operation manual or contact us for the power-supply capacity, etc.

External Dimensions

	Front view	Side view
SX4		

Option [Regenerative Resistor Unit]

Model REU-1

Description

This unit converts to heat the regenerative current generated when the motor decelerates. The controller has an internal regenerative resistor, but it does not offer enough capacity when the robot operates in tough conditions, in which case this regenerative unit is required. (Refer to the table on the right.)

Specification

Item	Specification
Main unit dimensions	W 34 mm x H 195 mm x D 126 mm
Main unit weight	0.9 kg
Built-in regenerative resistor	220 Ω 80 W
Accessories	Controller connection cable (Model: CB-ST-REU010): 1 m

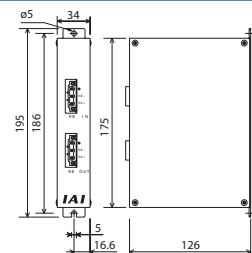

Option [Flange]

Use this flange when installing tooling, etc., at the end of the Z-axis of your Super-large SCARA NNN10040/NNN12040.

Model: IX-FL-5

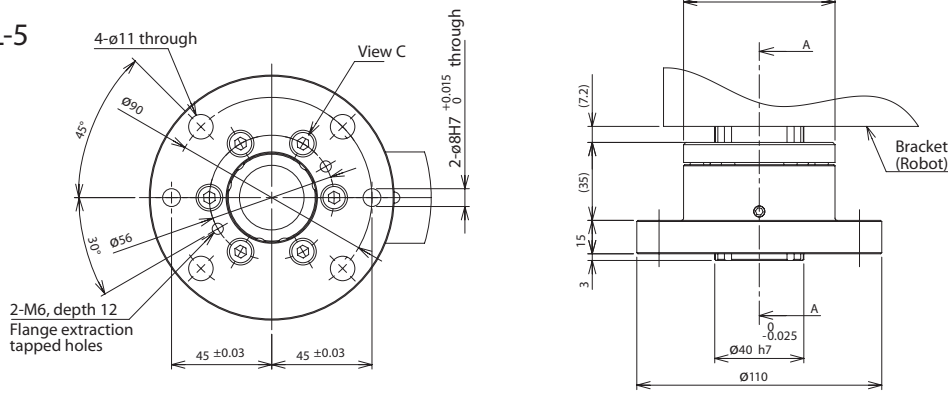

Reference for Operation Limits and Operation Settings

SCARA robots cannot operate continuously at the maximum acceleration/deceleration and maximum speed. If your robot must operate at the maximum acceleration/deceleration, provide stationary periods by referring to the "Reference for Continuous Operation Duties" graph.

If your robot must operate continuously, set its acceleration/deceleration by referring to the "Reference for Acceleration/Deceleration Settings" graph.

Note The "100% acceleration/deceleration" means that the maximum acceleration/deceleration at which the robot can operate optimally under the specified load condition represents 100%.

[The acceleration/deceleration represented by the 100% acceleration/deceleration when 20 to 50 kg is carried is not the same as the acceleration/deceleration represented by the 100% acceleration/deceleration when 0 to 20 kg is carried.]

Also note that the operation settings give priority to speed when the load is 0 to 20 kg, and to actuator behavior during operation as well as continuous operation when the load is over 20 kg.

Reference for Continuous Operation Duties



Reference for Acceleration/Deceleration Settings

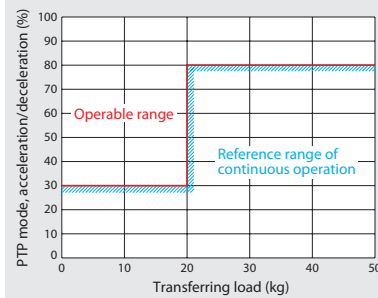

Limitations on Load Overhang/Speed Settings

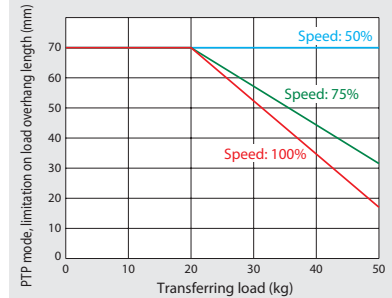

PTP Mode

Reference for Continuous Operation Duties

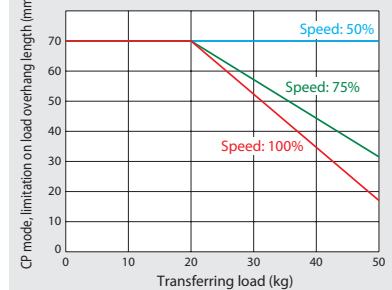
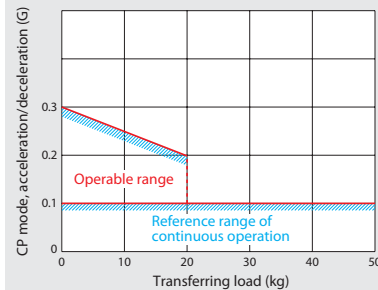
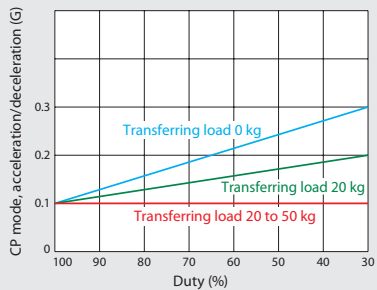

CP Mode