



## Standard Type NNN Series

The standard type combines the best performance and user-friendliness in its class. The wide selection of arm lengths (from a minimum of 250 mm to a maximum of 800 mm) provides the variety to accommodate a wide range of applications.

Arm length	Model	Page
250mm	IX-NNN2515H	P9
350mm	IX-NNN3515H	P10
500mm	IX-NNN5020H (5030H)	P11
600mm	IX-NNN6020H (6030H)	P12
700mm	IX-NNN7020H (7040H)	P13
800mm	IX-NNN8020H (8040H)	P14



## High-Speed Type NSN Series

The high-speed type offers enhanced performance at high-speed operation by combining a high-output motor with the standard body. This contributes to reduced cycle times.

Arm length	Model	Page
500mm	IX-NSN5016H	P15
600mm	IX-NSN6016H	P16



## Dustproof/Splash-proof Type NNW Series

The dustproof/splash-proof type adopts a protective structure conforming to IP65. This robot can be used in environments subject to powder dust or water splashes.

Arm length	Model	Page
250mm	IX-NNW2515H	P17
350mm	IX-NNW3515H	P18
500mm	IX-NNW5020H (5030H)	P19
600mm	IX-NNW6020H (6030H)	P20
700mm	IX-NNW7020H (7040H)	P21
800mm	IX-NNW8020H (8040H)	P22



## Wall Mount type TNN Series

This robot is mounted on a wall for operation. The space below the robot can be utilized effectively, so you will have more freedom in designing your equipment.

Arm length	Model	Page
300mm	IX-TNN3015H	P23
350mm	IX-TNN3515H	P24



## Description of Model Items

**Wall Mount Inverse Type****UNN** Series

This is the same as the wall mount type (TNN), but it is installed upside down. This is ideal for applications where the robot must handle loads from above.

Arm length	Model	Page
300mm	IX-UNN3015H	P23
350mm	IX-UNN3515H	P24

**Ceiling Mount Type****HNN** Series

This robot is mounted on a ceiling for operation. The space below the robot can be utilized effectively, so you will have more freedom in designing your equipment.

Arm length	Model	Page
500mm	IX-HNN5020H	P25
600mm	IX-HNN6020H	P26
700mm	IX-HNN7020H (7040H)	P27
800mm	IX-HNN8020H (8040H)	P28

**Inverse type****INN** Series

This is the same as the ceiling mount type (HNN), but it is installed upside down. This is ideal for applications where the robot must handle loads from above.

Arm length	Model	Page
500mm	IX-INN5020H	P25
600mm	IX-INN6020H	P26
700mm	IX-INN7020H (7040H)	P27
800mm	IX-INN8020H (8040H)	P28

**Clean Room Type****NNC** Series

This robot generates minimal particles and is ideal for operation in a clean room environment. The air inside the robot can be vacuumed if conformance to cleanliness class 10 is required.

Arm length	Model	Page
250mm	IX-NNC2515H	P29
350mm	IX-NNC3515H	P30
500mm	IX-NNC5020H (5030H)	P31
600mm	IX-NNC6020H (6030H)	P32
700mm	IX-NNC7020H (7040H)	P33
800mm	IX-NNC8020H (8040H)	P34



## Greatly reduced cycle time through improved high-speed performance

The IX series achieves best-in-class specifications in every aspect from high-speed performance and load capacity to repeated positioning accuracy.

### 1 Highest Speed, Load Capacity and Accuracy in Its Class

Standard cycle time: 0.28 sec. range <sup>(\*1)</sup>  
 Repeated positioning accuracy:  $\pm 0.01 \text{ mm} / \pm 0.005^\circ$  <sup>(\*2)</sup>  
 Maximum load capacity: 20 kg <sup>(\*3)</sup>

<sup>\*1</sup> The standard cycle time refers to the length of time for the arm to cycle back and forth over a vertical distance of 25 mm and a horizontal distance of 300 mm (rough positioning). This is based on an arm length of 500 for the high-speed type.

<sup>\*2</sup>  $\pm 0.015 \text{ mm} / \pm 0.005^\circ$  if the arm length is 700/800

<sup>\*3</sup> Based on an arm length of 700/800



### 2 Optimum Acceleration Function

By entering conditions, such as the transfer mass, and specifying the optimum acceleration for those conditions, operation at the minimum cycle time can easily be achieved.

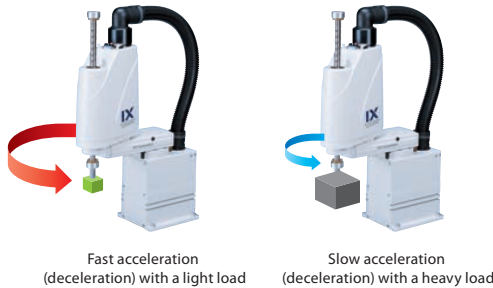

### 3 Improved Tracing Accuracy and Interpolation Function

The IX Series offers greatly improved tracing accuracy as a result of a more rigid body construction in addition to a higher controller processing speed.

The robot can also perform three-dimensional arc/pass motions to allow for easy and accurate dispensing operations.

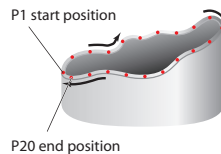

Command	Operation 1	Operation 2
PATH	P1	P20

Path movement consisting of many points can be implemented with a single line in the program.

### 4 Greater Ease of Use

An easily accessible D-sub/25-pin connector is provided on top of the robot for user connections. Two  $\phi 4$  and two  $\phi 6$  tube connectors are also available for any user tubing needs.

In addition, the brake-release switch on the robot allows you to release the brake even after the controller has been turned off.<sup>(\*1)</sup>

The alarm indicator alerts you of errors that occur on the robot.<sup>(\*2)</sup>

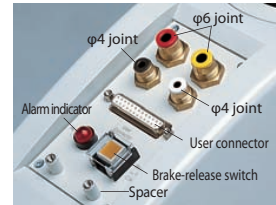

<sup>\*1</sup> 24 V DC power must be supplied regardless of whether or not the brake-release switch is used.

<sup>\*2</sup> In order to use the alarm indicator, it must be wired by the user.

### 5 Easy Programming

The IX Series uses programs written in the Super SEL language, a well-established command language used by Cartesian robots.

With Super SEL, complex operations can be programmed easily, allowing programs to be created quickly without prior knowledge of robot language.

### 6 Z-Axis Push Motion Function

With the Z-axis (vertical axis) push motion function, the robot can press-fit loads or control the torque.

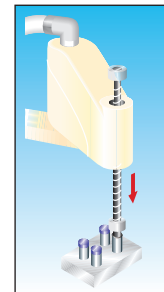

### 7 Simple Interference Check Zone Function

A maximum of 10 interference check zones can be set within the robot's work envelope. Since a signal is output when a load enters a check zone, this function is useful for conducting test operations at low speed.

<sup>\*1</sup> The load must remain inside a zone for at least 5 msec to ensure accurate detection.

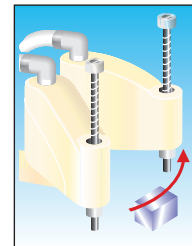



## 8 Complete Absolute Operation

All models adopt a 17-bit serial absolute encoder; therefore, accurate positioning can be performed without homing each time. If the need arises, an absolute reset can be performed easily and accurately using a dedicated jig. (Refer to "Robot Options" on p. 36.)

## 9 Widest Variations in the Industry

The IX Series provides the following variations:

- Standard Type
- High-Speed Type
- Clean Room Type
- Dustproof/Splash-proof Type
- Ceiling Mount Inverse Type

The five types listed above are suitable for a wide range of applications.

Table of Specifications IX SCARA Robot Series

Type	Arm length (mm) and maximum composite speed (mm/s)						Standard cycle time (sec)	Load capacity(*1) (kg)		Vertical axis stroke (mm)		Model	Page
	250 mm	350 mm	500 mm	600 mm	700 mm	800 mm		Rated	Maximum	Standard	Option		
Standard Type NNN	3191 mm/s						0.40	1	3	150	-	IX-NNN2515H	P9
		4042 mm/s					0.42	1	3	150	-	IX-NNN3515H	P10
			6381 mm/s				0.39	2	10	200	300	IX-NNN5020H (5030H)	P11
				7232 mm/s			0.43	2	10	200	300	IX-NNN6020H (6030H)	P12
					7010 mm/s		0.42	5	20	200	400	IX-NNN7020H (7040H)	P13
High-Speed Type NSN			5007 mm/s				0.28 range	1	3	160	-	IX-NSN5016H	P15
				5583 mm/s			0.29 range	1	3	160	-	IX-NSN6016H	P16
Dustproof/Splash-proof Type NNW	3191 mm/s						0.45	1	3	150	-	IX-NNW2515H	P17
		4042 mm/s					0.47	1	3	150	-	IX-NNW3515H	P18
			6381 mm/s				0.43	2	10	200	300	IX-NNW5020H (5030H)	P19
				7232 mm/s			0.47	2	10	200	300	IX-NNW6020H (6030H)	P20
					7010 mm/s		0.45	5	20	200	400	IX-NNW7020H (7040H)	P21
Wall Mount type TNN		3616 mm/s					0.41	1	3	150	-	IX-TNN3015H	P23
			4042 mm/s				0.42	1	3	150	-	IX-TNN3515H	P24
Wall Mount Inverse Type UNN		3616 mm/s					0.41	1	3	150	-	IX-UNN3015H	P23
			4042 mm/s				0.42	1	3	150	-	IX-UNN3515H	P24
Ceiling Mount Type HNN			6381 mm/s				0.39	2	10	200	-	IX-HNN5020H	P25
				7232 mm/s			0.43	2	10	200	-	IX-HNN6020H	P26
					7010 mm/s		0.42	5	20	200	400	IX-HNN7020H (7040H)	P27
						7586 mm/s	0.43	5	20	200	400	IX-HNN8020H (8040H)	P28
Inverse type INN			6381 mm/s				0.39	2	10	200	-	IX-INN5020H	P25
				7232 mm/s			0.43	2	10	200	-	IX-INN6020H	P26
					7010 mm/s		0.42	5	20	200	400	IX-INN7020H (7040H)	P27
						7586 mm/s	0.43	5	20	200	400	IX-INN8020H (8040H)	P28
Clean Room Type NNC	3191 mm/s						0.44	1	3	150	-	IX-NNC2515H	P29
		4042 mm/s					0.46	1	3	150	-	IX-NNC3515H	P30
			6381 mm/s				0.41	2	10	200	300	IX-NNC5020H (5030H)	P31
				7232 mm/s			0.45	2	10	200	300	IX-NNC6020H (6030H)	P32
					7010 mm/s		0.45	5	20	200	400	IX-NNC7020H (7040H)	P33
					7586 mm/s	0.46	5	20	200	400	IX-NNC8020H (8040H)	P34	

(\*1) The standard cycle times have been measured under the following conditions.

(Arm length 250 to 600) Reciprocating movement of a 2 kg load over a vertical distance of 25 mm and a horizontal distance of 300 mm  
(Arm length 700/800) Reciprocating movement of a 5 kg load over a vertical distance of 25 mm and a horizontal distance of 300 mm

(\*2) The rated load capacity refers to the maximum load that can be carried at the maximum operating speed. The maximum load capacity refers to the maximum load that can be carried at a reduced acceleration ratio.

## Notes IX SCARA Robot Series

### (Note 1) Repeated positioning accuracy

"Repeated positioning accuracy" refers to the positioning accuracy from the same start position to a single set position during repeated operation at the same speed and acceleration and with the same arm. (The values were measured at a constant ambient temperature of 20 °C.) This is not the same as "absolute positioning accuracy".

Note that the repeated positioning accuracy may be out of specification if the arm is changed, if the positioning is from multiple different positions to a single set position, or if the operating conditions, such as the operating speed and acceleration settings, are changed.

### (Note 2) Maximum operating speed

The specifications for the maximum operating speed represent the speed with PTP command operation.

Note that high-speed movement will be limited with CP command operation (interpolated movement).

In addition, movement at the descending end on a vertical axis requires appropriate reduction in speed and acceleration.

### (Note 3) Standard cycle time

"Standard cycle time" refers to the time required to cycle back and forth at maximum speed under the following conditions.

This is a general estimate of the high-speed performance (rough positioning).

(Arm length 250~600)	2 kg load; vertical distance: 25 mm; horizontal distance: 300 mm
(Arm length 700/800)	5 kg load; vertical distance: 25 mm; horizontal distance: 300 mm

<Note>

The standard cycle time is the required length of time when operating at maximum speed; however, the robot cannot operate continuously at maximum speed.

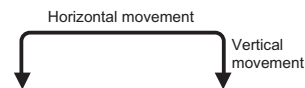

### (Note 4) Load capacity

"Load capacity" is the maximum mass that can be transferred. Specifications are listed for the rated load capacity and the maximum load capacity.

The rated load capacity is the maximum mass that can be transferred at maximum speed and maximum acceleration.

The maximum load capacity is the maximum mass that can be transferred at a reduced speed and acceleration.

When transferring a load between the rated load capacity and the maximum load capacity, an appropriate reduction in acceleration is required.

### (Note 5) Arm 3 (vertical axis) push force

"Axis 3 push force" is the push force applied by the tip of the vertical axis.

The maximum limit of the push force is 70% and 65% with the high-speed type. (The value noted under the 'maximum limit' column in the product specification section reflects this)

The minimum limit of the push force is 40% of the maximum push force.

The setting can be specified between 40% and 70% (40% and 65% for the high-speed type) of the maximum.

### (Note 6) Axis 4 allowable inertial moment

"Axis 4 allowable inertial moment" is the allowable inertial moment of axis 4 (rotating axis) of the SCARA robot as calculated at the center of rotation.

The offset from the center of rotation of axis 4 to the tool's gravity center must be within 40 mm.

If the tool's gravity center is further away from the center of axis 4, an appropriate reduction in speed and acceleration is required.

### (Note 7) Alarm indicator

The alarm indicator is located on top of arm 2 of the SCARA robot.

The alarm indicator can be wired to illuminate in certain conditions, such as when the controller generates an error. In order to use the alarm indicator, the user must provide a circuit that responds to the controller's I/O output signal by supplying 24 V DC to the applicable LED terminal in the user wiring.

### (Note 8) Brake-release switch

The brake-release switch is also located on top of arm 2 of the SCARA robot, near the alarm indicator.

In order to release the brake, 24 V DC power must be supplied, regardless of whether or not the brake-release switch is used. (Supply 24 V DC from a dedicated power supply separate from the 24 V DC power used to drive the I/O.)

### (Note 9) Cable length

The motor and encoder cables of the SCARA robot are directly connected to the robot. The IX Series does not use cable joints; therefore, changing the cable length on the delivered robot will be difficult. Select either 5 m (code 5L) or 10 m (code 10L) as the desired cable length when ordering. (The air tube length is 150 mm.)

### Work envelope

When performing an absolute reset or changing the arm, be careful that no peripherals will obstruct the arm when it fully extends.

### Acceleration settings

SCARA high-speed products operate at 100% of the maximum acceleration allowable for operation with each transfer mass.

If vibrations or overload errors occur, reduce the acceleration appropriately.

(Operating times differ with different transfer masses, even with the same acceleration and speed settings.)

**\*For reference acceleration settings, refer to p. 45.**

\*(Note 1) through (Note 9) correspond to notations on other pages of this document.

Refer to the opposite page for details on each item in the model number (① through ④).  
 The selection range for each item varies depending on the robot type. For details, refer to the page corresponding to each type.

[IX-□□□2515H/3515H/50□□H/60□□H/70□□H/80□□H series]

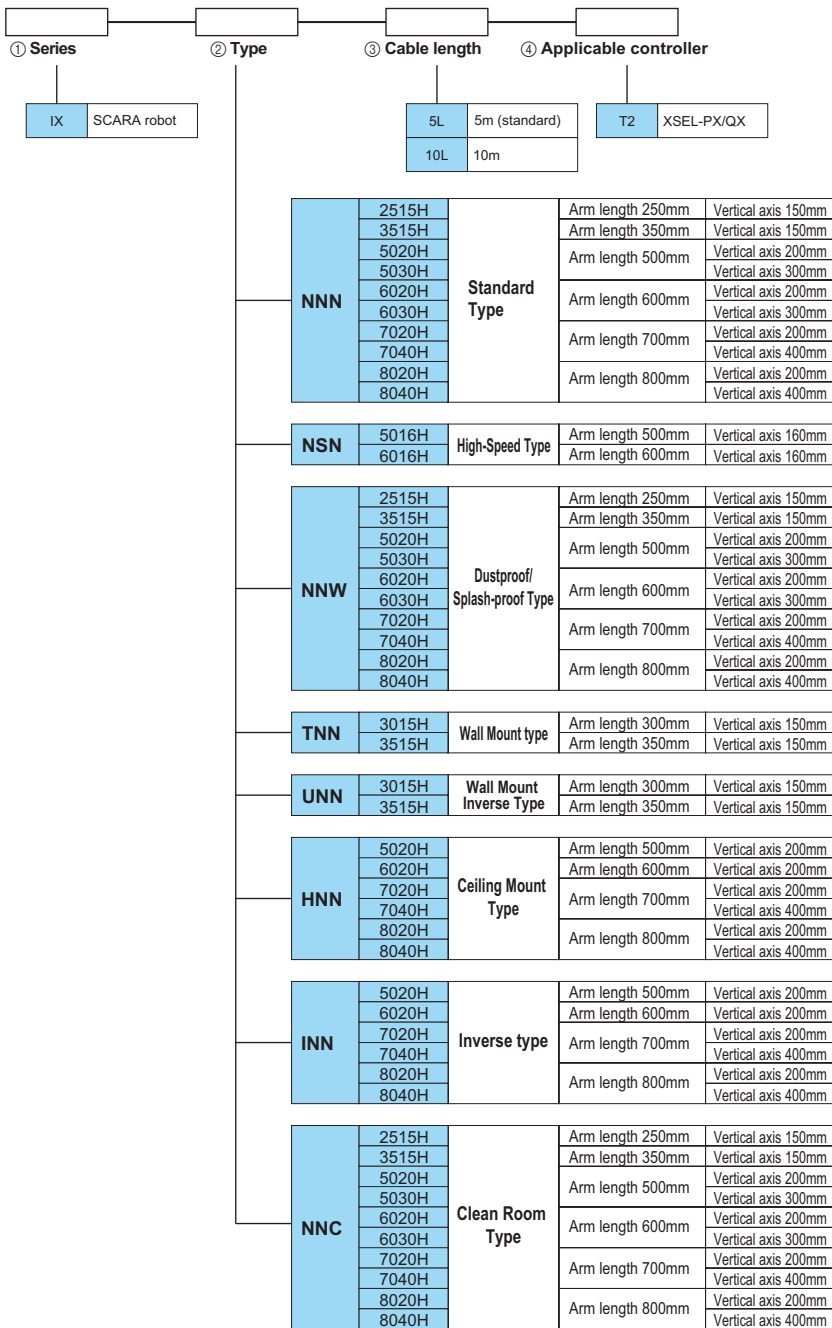



## Description of Model Items

### ① Series

Indicate the name of each series.

### ② Type

Indicate the type (standard, high-speed, dustproof/splash-proof, wall-mount, ceiling-mount or clean room), arm length and Z-axis length.

NNN	Standard Type	UNN	Wall Mount Inverse Type
NSN	High-Speed Type	HNN	Ceiling Mount Type
NNW	Dustproof/Splash-proof Type	INN	Ceiling Mount Inverse Type
TNN	Wall Mount type	NNC	Clean Room Type

### ③ Cable length

Indicate the length of cable connecting the robot and the controller.  
Select from two lengths: 5 m (standard) and 10 m.

### ④ Applicable controller

Indicate the type of controller to be connected.  
T2:XSEL-PX/QX

# IX-NNN2515H

Small SCARA robot, Standard type  
Arm length 250mm, Vertical axis 150mm



<b>Model items</b>	<b>IX</b>	<b>— NNN2515H</b>	<b>□</b>	<b>— T2</b>
Series	Type	Cable length	Applicable controller	
Standard type		5L : 5 m (standard)	T2: XSEL-PX/QX	
Arm length 250mm		10L : 10 m		
Vertical axis 150mm				

\*For details on the model items, refer to page 8.

### Model/Specifications

Model	Axis configuration		Arm length (mm)	Motor capacity (W)	Work envelope	Positioning Repeatability (mm) (Note 1)	PTP operation Maximum operating speed (Note 2)	Standard cycle time (sec) (Note 3)	Load capacity (kg) (Note 4)		Axis 3 (vertical axis) push force (N) (Note 5)		Axis 4 allowable load		
	Axis 1	Axis 2							Rated	Maximum	Maximum limit	Minimum limit	Allowable inertial moment (kg·m <sup>2</sup> ) (Note 6)	Allowable torque (N·m)	
IX-NNN2515H-□-T2	Arm 1	Arm 2	125	200	±120°	±0.010 (XY)	3191 mm/s (Composite speed)	0.40	1	3	111.0	58.0	0.015	1.9	
	Vertical axis	-	100	150mm	±130°										±0.010
	Rotating axis	-	50	±360°	±0.005	1600°/s									

\*In the model number above, specify the cable length in □.

\*SCARA robots cannot operate continuously at 100% speed and acceleration. For details on the operating conditions, refer to Reference Acceleration/Deceleration Settings on page 45.

### Common Specifications

Encoder type	Absolute
User wiring	15-conductor AWG26 D-sub/15-pin connector with shield (socket)
User tubing	Air tube (O.D. $\varnothing 4$ , I.D. $\varnothing 2.5$ ) x 3 (Normal working pressure 0.8 MPa)
Alarm indicator (Note 7)	Small red LED indicator x 1 (24 V DC must be supplied.)
Brake-release switch (Note 8)	Allows remote release of Z-axis (24 VDC required)

Ambient temperature/humidity	Temperature: 0–40 °C, humidity: 20–85%RH or less (no condensation)
Unit weight	17.1Kg
Applicable controller	T2: XSEL-PX/QX
Cable length (Note 9)	5L: 5 m (standard), 10L: 10 m (optional)

### Dimensions

The CAD drawings can be downloaded from our Web site.

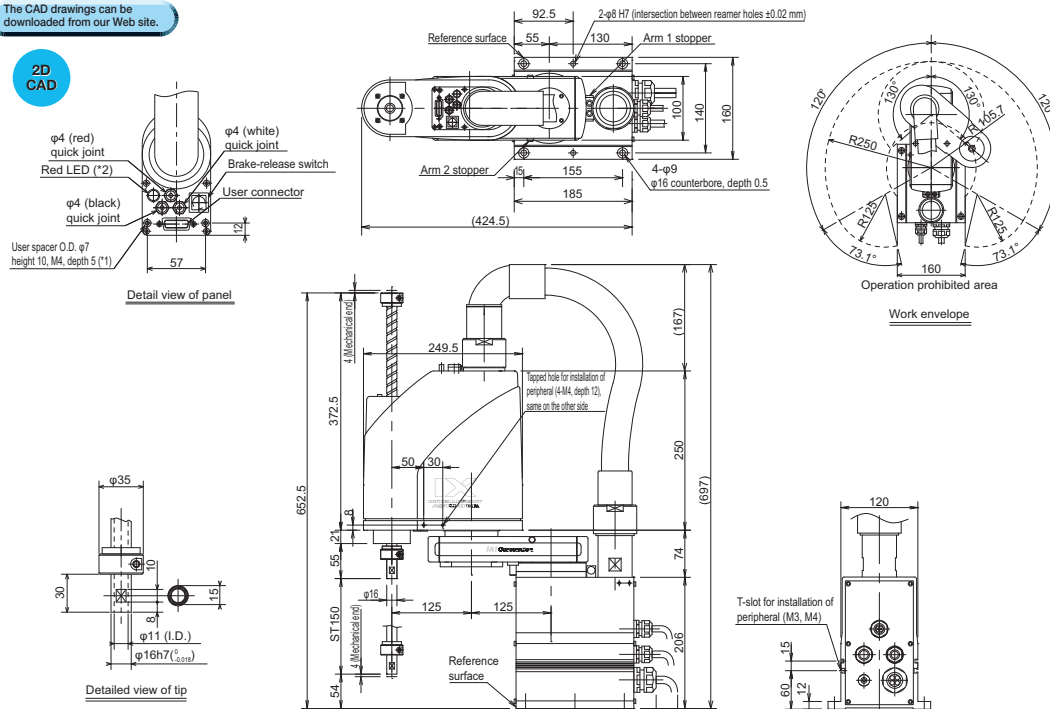

\*1: The external force applied to a spacer must not exceed 30 N in the axial direction, or 2 N·m in the rotating direction. (for each spacer)  
\*2: In order to use the LED, the user must wire it so that it responds to the controller's I/O output signal by supplying 24 V DC to the applicable LED terminal in the user wiring.

- Cables/tubes
- Motor/encoder cable 5 m/10 m
- Brake power cable 5 m/10 m
- User wiring cable 5 m/10 m
- Air tube (3 pcs) 0.15m

### Applicable Controller Specifications

Applicable Controller	Features	Maximum I/O points (inputs/outputs)	Power-supply voltage	Reference page
XSEL-PX	Maximum 6 axes, 2400 W supported	192/192 points	Three-phase 200 V AC	p. 37
XSEL-QX	Safety Category 4 supported			



For explanations of (Note 1) through (Note 9), refer to page 6.

# IX-NNN3515H

Small SCARA robot, Standard type  
Arm length 350mm, Vertical axis 150mm



Model items	IX — NNN3515H —	□	T2
Series	Type	Cable length	Applicable controller
Standard type		5L : 5 m (standard)	T2: XSEL-PX/QX
Arm length 350mm		10L : 10 m	
Vertical axis 150mm			

\*For details on the model items, refer to page 8.

## Model/Specifications

Model	Axis configuration	Arm length (mm)	Motor capacity (W)	Work envelope	Positioning Repeatability (mm) (Note 1)	PTP operation Maximum operating speed (Note 2)	Standard cycle time (sec) (Note 3)	Load capacity (kg) (Note 4)		Axis 3 (vertical axis) push force (N) (Note 5)		Axis 4 allowable load	
								Rated	Maximum	Maximum limit	Minimum limit	Allowable inertial moment (kg·m <sup>2</sup> ) (Note 6)	Allowable torque (N·m)
IX-NNN3515H-□-T2	Axis 1 Arm 1	225	200	±120°	±0.010 (XY)	4042mm/s (Composite speed) 1316mm/s	0.42	1	3	111.0	58.0	0.015	1.9
	Axis 2 Arm 2	125	100	±135°	±0.010								
	Axis 3 Vertical axis	-	100	150mm	±0.010								
	Axis 4 Rotating axis	-	50	±360°	±0.005								

\*In the model number above, specify the cable length in □.

\*SCARA robots cannot operate continuously at 100% speed and acceleration. For details on the operating conditions, refer to Reference Acceleration/Deceleration Settings on page 45.

## Common Specifications

Encoder type	Absolute
User wiring	15-conductor AWG26 D-sub/15-pin connector with shield (socket)
User tubing	Air tube (O.D. $\phi 4$ , I.D. $\phi 2.5$ ) x 3 (Normal working pressure 0.8 MPa)
Alarm indicator (Note 7)	Small red LED indicator x 1 (24 V DC must be supplied.)
Brake-release switch (Note 8)	Allows remote release of Z-axis (24 VDC required)

Ambient temperature/humidity	Temperature: 0-40 °C, humidity: 20-85%RH or less (no condensation)
Unit weight	18.2Kg
Applicable controller	T2: XSEL-PX/QX
Cable length (Note 9)	5L: 5 m (standard), 10L: 10 m (optional)

## Dimensions

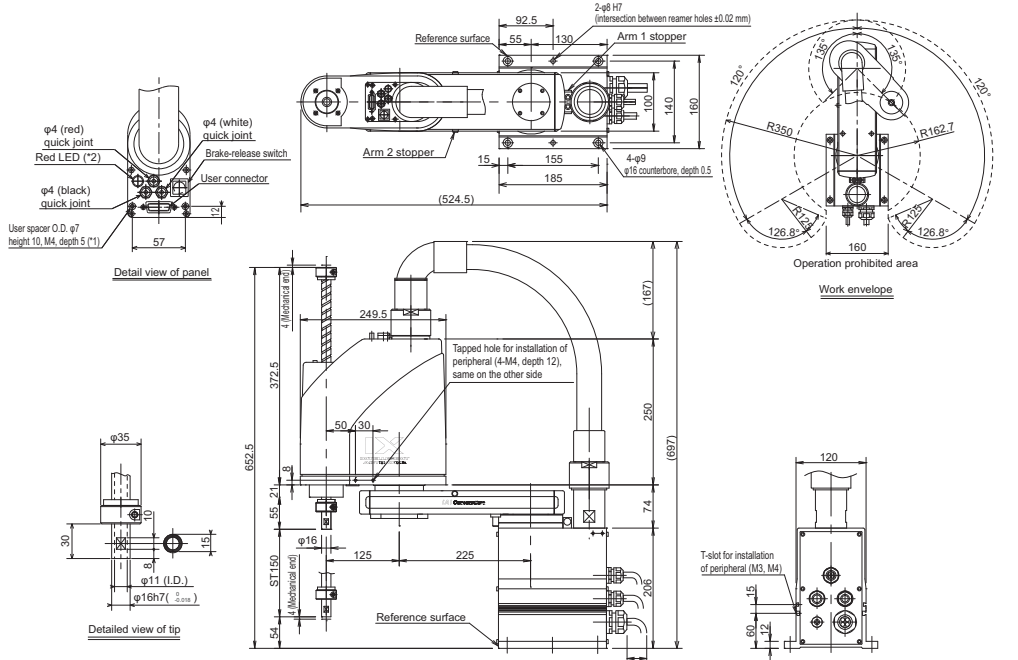

\*1: The external force applied to a spacer must not exceed 30 N in the axial direction, or 2 N·m in the rotating direction. (for each spacer)

\*2: In order to use the LED, the user must wire it so that it responds to the controller's I/O output signal by supplying 24 V DC to the applicable LED terminal in the user wiring.

Maintain at 100 mm or more

Cables/tubes

- Motor/encoder cable 5 m/10 m
- Brake power cable 5 m/10 m

- User wiring cable 5 m/10 m
- Air tube (3 pcs) 0.15m

## Applicable Controller Specifications

Applicable Controller	Features	Maximum I/O points (inputs/outputs)	Power-supply voltage	Reference page
XSEL-PX	Maximum 6 axes, 2400 W supported	192/192 points	Three-phase 200 V AC	p. 37
XSEL-QX	Safety Category 4 supported			



For explanations of (Note 1) through (Note 9), refer to page 6.

# IX-NNN50□□H

Medium SCARA robot, Standard type  
 Arm length 500mm  
 Vertical axis 200mm (300mm)



## Model items IX — NNN50□□H — □ — T2

Series	Type	Cable length	Applicable controller
NNN5020H : Standard type Arm length 500mm, Vertical axis 200mm		5L : 5 m (standard) 10L : 10 m	T2: XSEL-PX/QX
NNN5030H : Standard type Arm length 500mm, Vertical axis 300mm			

\*For details on the model items, refer to page 8.

### Model/Specifications

Model	Axis configuration		Arm length (mm)	Motor capacity (W)	Work envelope	Positioning Repeatability (mm) (Note 1)	PTP operation Maximum operating speed (Note 2)	Standard cycle time (sec) (Note 3)	Load capacity (kg) (Note 4)		Axis 3 (vertical axis) push force (N) (Note 5)		Axis 4 allowable load	
	Rated	Maximum							Maximum limit	Minimum limit	Allowable inertial moment (kg·m <sup>2</sup> ) (Note 6)	Allowable torque (N·m)		
IX-NNN5020H-□□-T2 [IX-NNN5030H-□□-T2]	Axis 1	Arm 1	250	400	±120°	±0.010 (XY)	6381mm/s (Composite speed)	0.39	2	10	181.0	93	0.06	3.7
	Axis 2	Arm 2	250	200	±145°									
	Axis 3	Vertical axis	-	200	200mm [300mm]	±0.010	1473mm/s							
	Axis 4	Rotating axis	-	100	±360°	±0.005	1857°/s							

\*In the model number above, specify the cable length in □.

\*SCARA robots cannot operate continuously at 100% speed and acceleration. For details on the operating conditions, refer to Reference Acceleration/Deceleration Settings on page 45.

### Common Specifications

Encoder type	Absolute
User wiring	25-conductor AWG26 D-sub/25-pin connector with shield (socket)
User tubing	Air tube (O.D. $\phi 6$ , I.D. $\phi 4$ ) x 2 (Normal working pressure 0.8 MPa) Air tube (O.D. $\phi 4$ , I.D. $\phi 2.5$ ) x 2 (Normal working pressure 0.8 MPa)
Alarm indicator (Note 7)	Small red LED indicator x 1 (24 V DC must be supplied.)
Brake-release switch (Note 8)	Allows remote release of Z-axis (24 VDC required)

Ambient temperature/humidity	Temperature: 0-40 °C, humidity: 20-85%RH or less (no condensation)
Unit weight	29.5Kg
Applicable controller	T2: XSEL-PX/QX
Cable length (Note 9)	5L: 5 m (standard), 10L: 10 m (optional)

### Dimensions

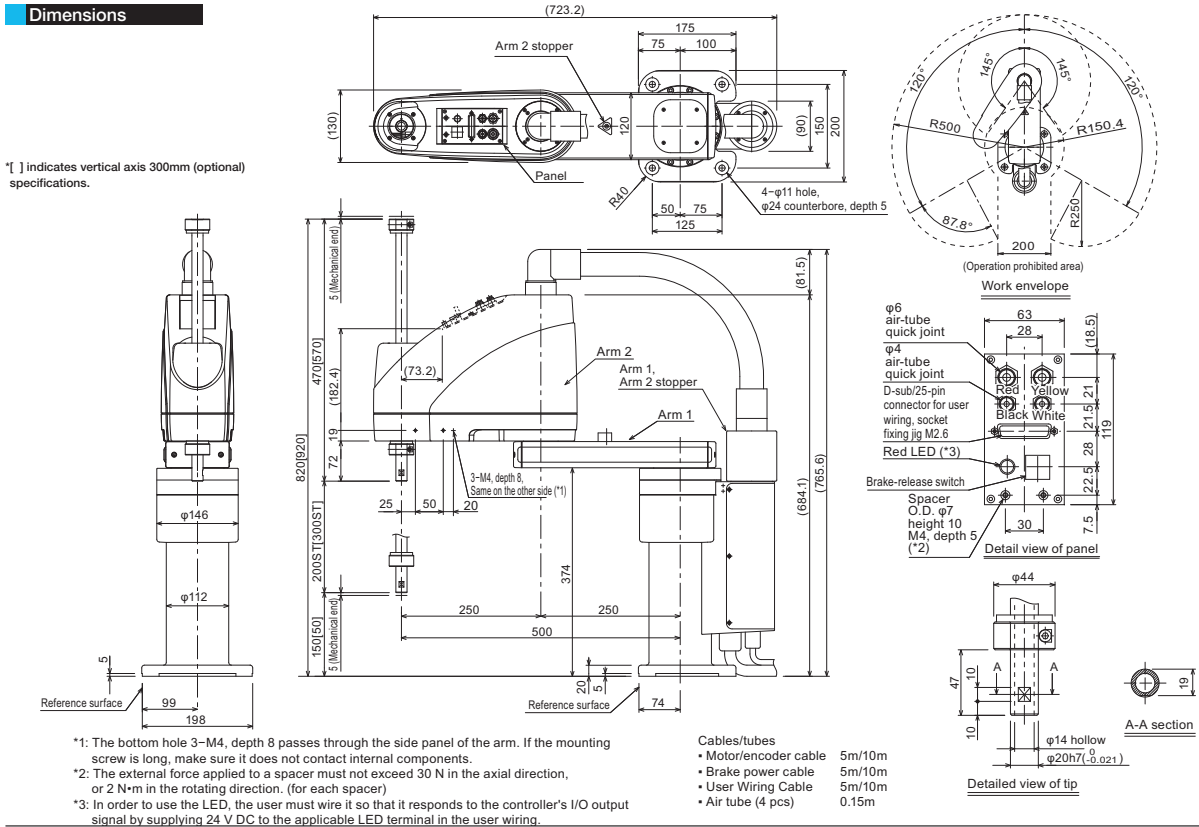

### Applicable Controller Specifications

Applicable Controller	Features	Maximum I/O points (inputs/outputs)	Power-supply voltage	Reference page
XSEL-PX	Maximum 6 axes, 2400 W supported	192/192 points	Three-phase 200 V AC	p. 37
XSEL-QX	Safety Category 4 supported			



For explanations of (Note 1) through (Note 9), refer to page 6.

# IX-NNN60□□H

Medium SCARA robot, Standard type  
 Arm length 600mm  
 Vertical axis 200mm (300mm)



## Model items IX — NNN60□□H — □ — T2

Series	Type	Cable length	Applicable controller
NNN6020H : Standard type Arm length 600mm, Vertical axis 200mm		5L : 5 m (standard) 10L: 10 m	T2: XSEL-PX/QX
NNN6030H : Standard type Arm length 600mm, Vertical axis 300mm			

\*For details on the model items, refer to page 8.

### Model/Specifications

Model	Axis configuration	Arm length (mm)	Motor capacity (W)	Work envelope	Positioning Repeatability (mm) (Note 1)	PTP operation Maximum operating speed (Note 2)	Standard cycle time (sec) (Note 3)	Load capacity (kg) (Note 4)		Axis 3 (vertical axis) push force (N) (Note 5)		Axis 4 allowable load		
								Rated	Maximum	Maximum limit	Minimum limit	Allowable inertial moment (kg·m <sup>2</sup> ) (Note 6)	Allowable torque (N·m)	
IX-NNN6020H-□-T2 [IX-NNN6030H-□-T2]	Axis 1	Arm 1	350	400	±120°	7232mm/s	0.43	2	10	181.0	93	0.06	3.7	
	Axis 2	Arm 2	250	200	±145°	(Composite speed)								
	Axis 3	Vertical axis	-	200	200mm [300mm]	±0.010								1473mm/s
	Axis 4	Rotating axis	-	100	±360°	±0.005								1857°/s

\*In the model number above, specify the cable length in □.

\*SCARA robots cannot operate continuously at 100% speed and acceleration. For details on the operating conditions, refer to Reference Acceleration/Deceleration Settings on page 45.

### Common Specifications

Encoder type	Absolute
User wiring	25-conductor AWG26 D-sub/25-pin connector with shield (socket)
User tubing	Air tube (O.D. $\phi 6$ , I.D. $\phi 4$ ) x 2 (Normal working pressure 0.8 MPa) Air tube (O.D. $\phi 4$ , I.D. $\phi 2.5$ ) x 2 (Normal working pressure 0.8 MPa)
Alarm indicator (Note 7)	Small red LED indicator x 1 (24 V DC must be supplied.)
Brake-release switch (Note 8)	Allows remote release of Z-axis (24 VDC required)

Ambient temperature/humidity	Temperature: 0-40 °C, humidity: 20-85%RH or less (no condensation)
Unit weight	30.5Kg
Applicable controller	T2: XSEL-PX/QX
Cable length (Note 9)	5L: 5 m (standard), 10L: 10 m (optional)

### Dimensions

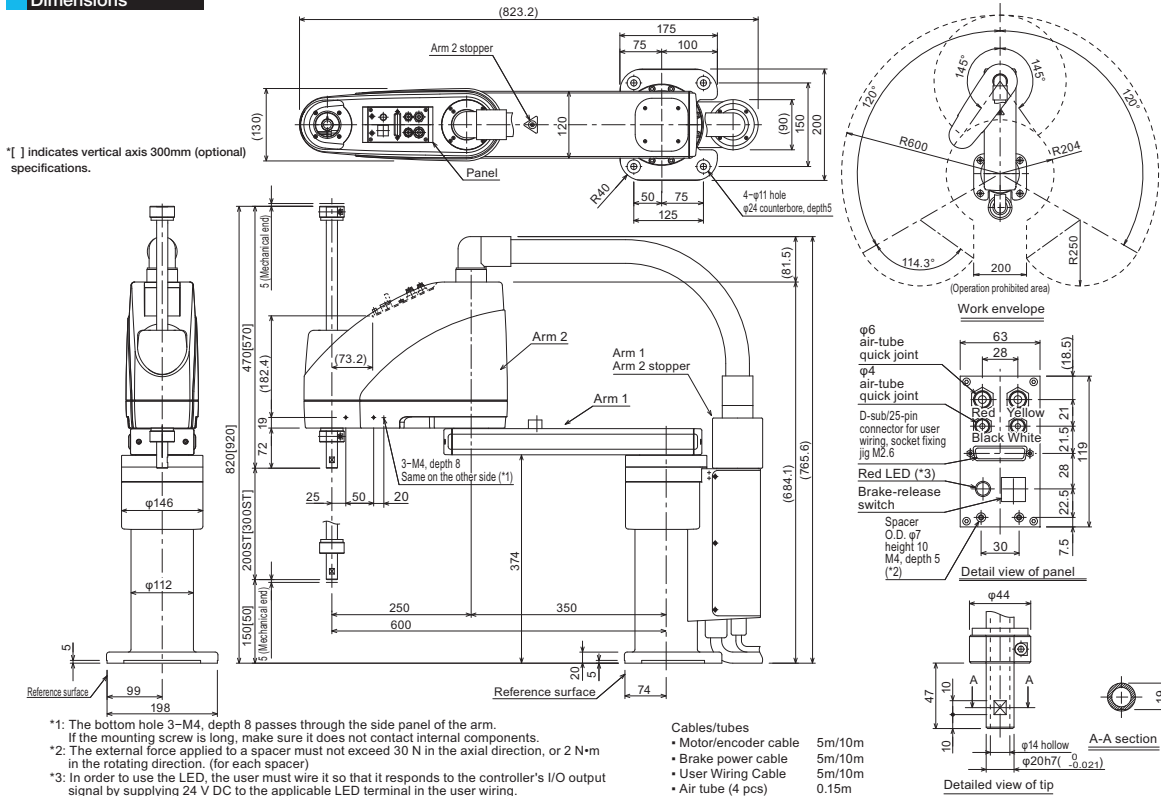

### Applicable Controller Specifications

Applicable Controller	Features	Maximum I/O points (inputs/outputs)	Power-supply voltage	Reference page
XSEL-PX	Maximum 6 axes, 2400 W supported	192/192 points	Three-phase 200 V AC	p. 37
XSEL-QX	Safety Category 4 supported			



For explanations of (Note 1) through (Note 9), refer to page 6.

# IX-NNN70□□H

Large SCARA robot, Standard type  
Arm length 700mm  
Vertical axis 200mm (400mm)



## Model items IX — NNN70□□H — □ — T2

Series	Type	Cable length	Applicable controller
NNN7020H : Standard type		5L : 5 m (standard)	T2: XSEL-PX/QX
Arm length 700mm, Vertical axis 200mm		10L: 10 m	
NNN7040H : Standard type			
Arm length 700mm, Vertical axis 400mm			

\*For details on the model items, refer to page 8.

### Model/Specifications

Model	Axis configuration		Arm length (mm)	Motor capacity (W)	Work envelope	Positioning Repeatability (mm) (Note 1)	PTP operation Maximum operating speed (Note 2)	Standard cycle time (sec) (Note 3)	Load capacity (kg) (Note 4)		Axis 3 (vertical axis) push force (N) (Note 5)		Axis 4 allowable load	
	Rated	Maximum							Maximum limit	Minimum limit	Allowable inertial moment (kg·m <sup>2</sup> ) (Note 6)	Allowable torque (N·m)		
IX-NNN7020H-□□-T2 [IX-NNN7040H-□□-T2]	Axis 1	Arm 1	350	750	±125°	±0.015 (XY)	7010mm/s (Composite speed)	0.42	5	20	304	146.0	0.1	11.7
	Axis 2	Arm 2	350	400	±145°									
	Axis 3	Vertical axis	-	400	200mm [400mm]	±0.010	1614mm/s							
	Axis 4	Rotating axis	-	200	±360°	±0.005	1266°/s							

\*In the model number above, specify the cable length in □.

\*SCARA robots cannot operate continuously at 100% speed and acceleration. For details on the operating conditions, refer to Reference Acceleration/Deceleration Settings on page 46.

### Common Specifications

Encoder type	Absolute
User wiring	25-conductor AWG26 D-sub/25-pin connector with shield (socket)
User tubing	Air tube (O.D. $\phi$ 6, I.D. $\phi$ 4) x 2 (Normal working pressure 0.8 MPa)
Alarm indicator (Note 7)	Small red LED indicator x 1 (24 V DC must be supplied.)
Brake-release switch (Note 8)	Allows remote release of Z-axis (24 VDC required)

Ambient temperature/humidity	Temperature: 0-40 °C, humidity: 20-85%RH or less (no condensation)
Unit weight	58Kg
Applicable controller	T2: XSEL-PX/QX
Cable length (Note 9)	5L: 5 m (standard), 10L: 10 m (optional)

### Dimensions

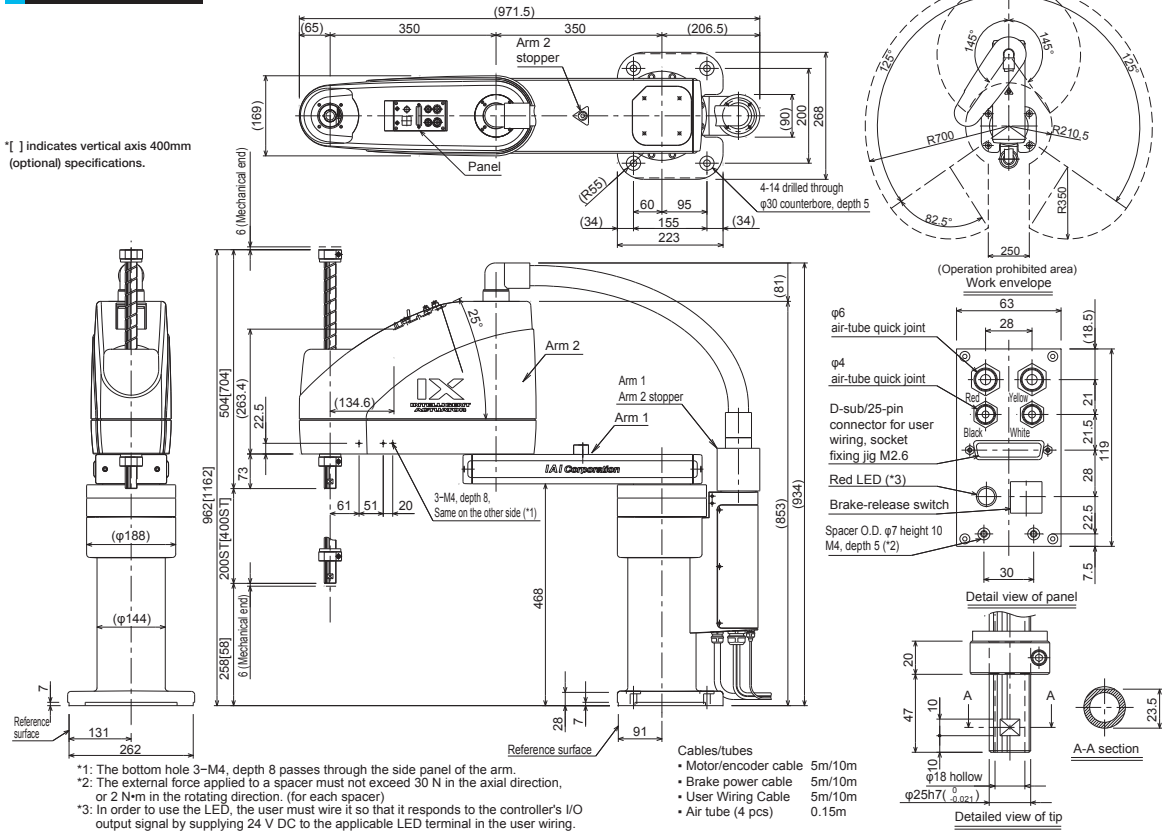

### Applicable Controller Specifications

Applicable Controller	Features	Maximum I/O points (inputs/outputs)	Power-supply voltage	Reference page
XSEL-PX	Controller dedicated to SCARA	192/192 points	Three-phase 200 V AC	p. 37
XSEL-QX	Safety Category 4 supported			



For explanations of (Note 1) through (Note 9), refer to page 6.

# 13

IX-NNN70□□H

# IX-NNN80□□H

Large SCARA robot, Standard type  
Arm length 800mm  
Vertical axis 200mm (400mm)



## Model items IX — NNN80□□H — □ — T2

Series	Type	Cable length	Applicable controller
NNN8020H : Standard type Arm length 800mm, Vertical axis 200mm	□	5L : 5 m (standard)	T2: XSEL-PX/QX
NNN8040H : Standard type Arm length 800mm, Vertical axis 400mm		10L: 10 m	

\*For details on the model items, refer to page 8.

### Model/Specifications

Model	Axis configuration	Arm length (mm)	Motor capacity (W)	Work envelope	Positioning Repeatability (mm) (Note 1)	PTP operation Maximum operating speed (Note 2)	Standard cycle time (sec) (Note 3)	Load capacity (kg) (Note 4)		Axis 3 (vertical axis) push force (N) (Note 5)		Axis 4 allowable load		
								Rated	Maximum	Maximum limit	Minimum limit	Allowable inertial moment (kg·m <sup>2</sup> ) (Note 6)	Allowable torque (N·m)	
IX-NNN8020H-□-T2 [IX-NNN8040H-□-T2]	Axis 1	Arm 1	450	750	±125°	7586mm/s (Composite speed)	0.43	5	20	304	146.0	0.1	11.7	
	Axis 2	Arm 2	350	400	±145°									±0.015 (XY)
	Axis 3	Vertical axis	-	400	200mm [400mm]	±0.010								1614mm/s
	Axis 4	Rotating axis	-	200	±360°	±0.005								1266°/s

\*In the model number above, specify the cable length in □.

\*SCARA robots cannot operate continuously at 100% speed and acceleration. For details on the operating conditions, refer to Reference Acceleration/Deceleration Settings on page 46.

### Common Specifications

Encoder type	Absolute
User wiring	25-conductor AWG26 D-sub/25-pin connector with shield (socket)
User tubing	Air tube (O.D. $\phi$ 6, I.D. $\phi$ 4) x 2 (Normal working pressure 0.8 MPa) Air tube (O.D. $\phi$ 4, I.D. $\phi$ 2.5) x 2 (Normal working pressure 0.8 MPa)
Alarm indicator (Note 7)	Small red LED indicator x 1 (24 V DC must be supplied.)
Brake-release switch (Note 8)	Allows remote release of Z-axis (24 VDC required)

Ambient temperature/humidity	Temperature: 0-40 °C, humidity: 20-85%RH or less (no condensation)
Unit weight	60Kg
Applicable controller	T2: XSEL-PX/QX
Cable length (Note 9)	5L: 5 m (standard), 10L: 10 m (optional)

### Dimensions

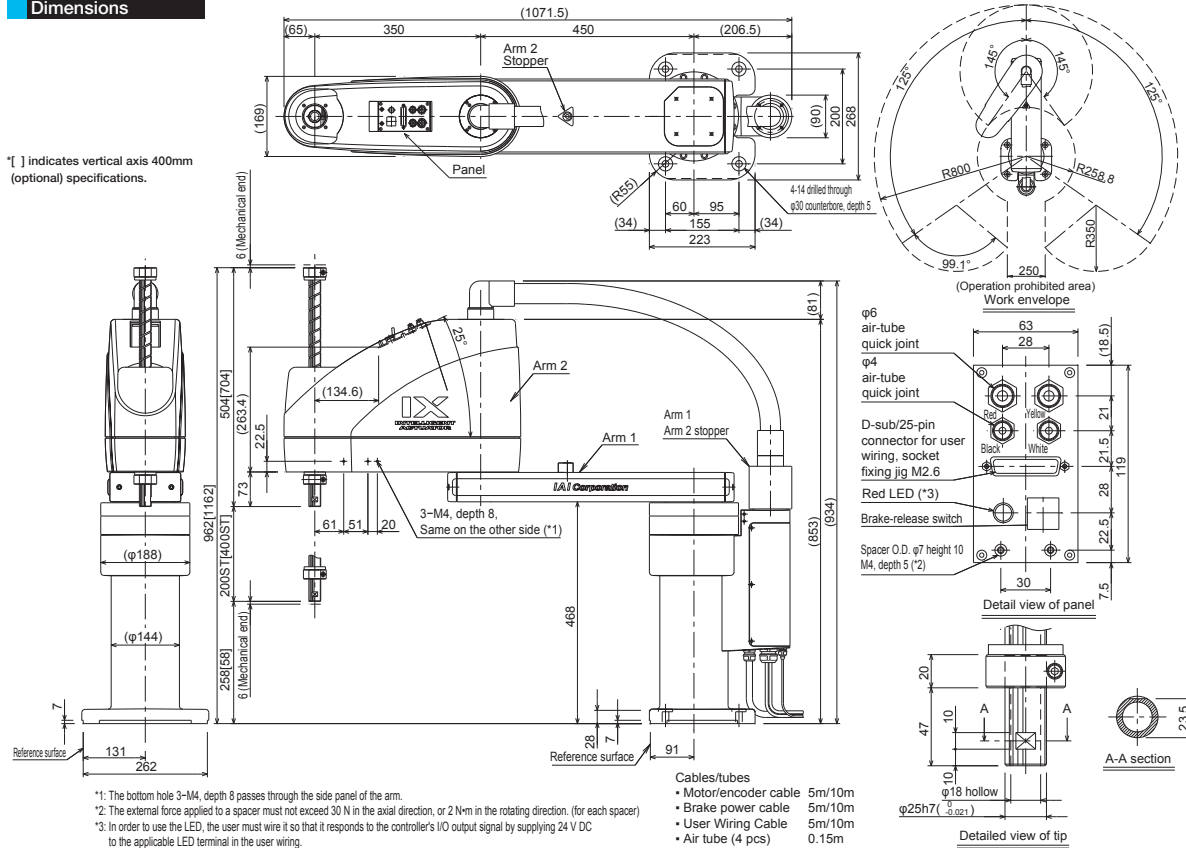

### Applicable Controller Specifications

Applicable Controller	Features	Maximum I/O points (inputs/outputs)	Power-supply voltage	Reference page
XSEL-PX	Controller dedicated to SCARA	192/192 points	Three-phase 200 V AC	p. 37
XSEL-QX	Safety Category 4 supported			



For explanations of (Note 1) through (Note 9), refer to page 6.

IX-NNN80□□H

# 14

# IX-NSN5016H Medium SCARA robot, High-speed type

Arm length 500mm, Vertical axis 160mm



## Model items IX — NSN5016H — — T2

Series	Type	Cable length	Applicable controller
High-speed type		5L :5 m (standard)	T2: XSEL-PX/QX
Arm length 500mm		10L:10 m	
Vertical axis 160mm			

### Model/Specifications

Model	Axis configuration		Arm length (mm)	Motor capacity (W)	Work envelope	Positioning Repeatability (mm) (Note 1)	PTP operation Maximum operating speed (Note 2)	Standard cycle time (sec) (Note 3)	Load capacity (kg) (Note 4)		Axis 3 (vertical axis) push force (N) (Note 5)		Axis 4 allowable load	
	Rated	Maximum							Maximum limit	Minimum limit	Allowable inertial moment (kg·m <sup>2</sup> ) (Note 6)	Allowable torque (N·m)		
IX-NSN5016H- <span style="border: 1px solid black; display: inline-block; width: 15px; height: 15px;"></span> -T2	Axis 1	Arm 1	250	750	±120°	±0.010 (XY)	5007mm/s (Composite speed)	0.28 range	1	3	196.0	116.0	0.015	3.7
	Axis 2	Arm 2	250	600	±145°									
	Axis 3	Vertical axis	-	200	160mm	±0.010	1304mm/s							
	Axis 4	Rotating axis	-	100	±360°	±0.010	1857°/s							

\*In the model number above, specify the cable length in .

\*SCARA robots cannot operate continuously at 100% speed and acceleration. For details on the operating conditions, refer to Reference Acceleration/Deceleration Settings on page 46.

### Common Specifications

Encoder type	Absolute
User wiring	25-conductor AWG26 D-sub/25-pin connector with shield (socket)
User tubing	Air tube (O.D. ø6, I.D. ø4) x 2 (Normal working pressure 0.8 MPa)
	Air tube (O.D. ø4, I.D. ø2.5) x 2 (Normal working pressure 0.8 MPa)
Alarm indicator (Note 7)	Small red LED indicator x 1 (24 V DC must be supplied.)
Brake-release switch (Note 8)	Allows remote release of Z-axis (24 VDC required)

Ambient temperature/humidity	Temperature: 0-40 °C, humidity: 20-85%RH or less (no condensation)
Unit weight	32Kg
Applicable controller	T2: XSEL-PX/QX
Cable length (Note 9)	5L: 5 m (standard), 10L: 10 m (optional)

### Dimensions

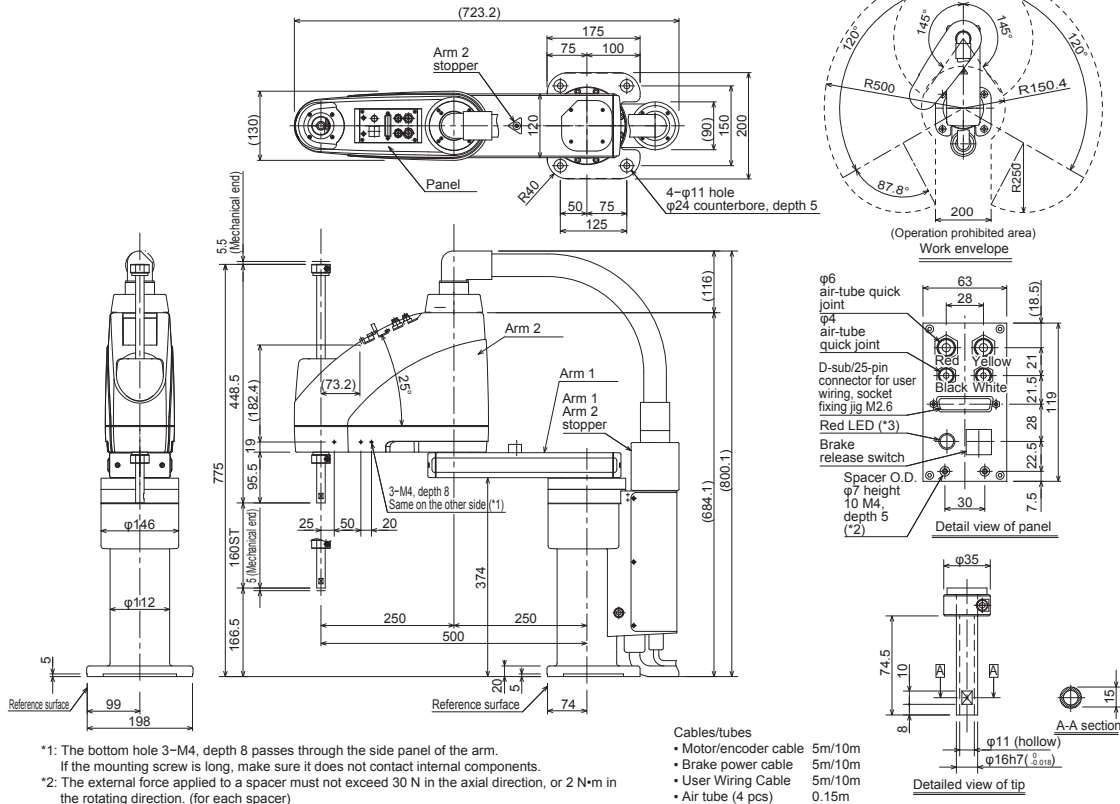

- \*1: The bottom hole 3-M4, depth 8 passes through the side panel of the arm. If the mounting screw is long, make sure it does not contact internal components.
- \*2: The external force applied to a spacer must not exceed 30 N in the axial direction, or 2 N·m in the rotating direction. (for each spacer)
- \*3: In order to use the LED, the user must wire it so that it responds to the controller's I/O output signal by supplying 24 V DC to the applicable LED terminal in the user wiring.

### Applicable Controller Specifications

Applicable Controller	Features	Maximum I/O points	Power-supply voltage	Reference page
XSEL-PX	Controller dedicated to SCARA	192/192 points	Three-phase 200 V AC	p. 37
XSEL-QX	Safety Category 4 supported			

\*When operating the high-speed type, a PX/QX single-axis robot cannot be connected.



For explanations of (Note 1) through (Note 9), refer to page 6.

**15** IX-NSN5016H



# IX-NSN6016H

Medium SCARA robot, High-speed type  
Arm length 600mm, Vertical axis 160mm

IX SCARA

IX SCARA



## Model items IX — NSN6016H — T2

Series	Type	Cable length	Applicable controller
High-speed type		5L : 5 m (standard)	T2: XSEL-PX/QX
Arm length 600mm		10L : 10 m	
Vertical axis 160mm			

\*For details on the model items, refer to page 8.

### Model/Specifications

Model	Axis configuration		Arm length (mm)	Motor capacity (W)	Work envelope	Positioning Repeatability (mm) (Note 1)	PTP operation Maximum operating speed (Note 2)	Standard cycle time (sec) (Note 3)	Load capacity (kg) (Note 4)		Axis 3 (vertical axis) push force (N) (Note 5)		Axis 4 allowable load	
	Rated	Maximum							Maximum limit	Minimum limit	Allowable inertial moment (kg·m <sup>2</sup> ) (Note 6)	Allowable torque (N·m)		
IX-NSN6016H-□-T2	Axis 1	Arm 1	350	750	±120°	±0.010 (XY)	5583mm/s (Composite speed)	0.29 range	1	3	196.0	116.0	0.015	3.7
	Axis 2	Arm 2	250	600	±145°									
	Axis 3	Vertical axis	-	200	160mm	±0.010	1304mm/s							
	Axis 4	Rotating axis	-	100	±360°	±0.010	1857°/s							

\*In the model number above, specify the cable length in □.

\*SCARA robots cannot operate continuously at 100% speed and acceleration. For details on the operating conditions, refer to Reference Acceleration/Deceleration Settings on page 46.

### Common Specifications

Encoder type	Absolute
User wiring	25-conductor AWG26 D-sub/25-pin connector with shield (socket)
User tubing	Air tube (O.D. $\varnothing 6$ , I.D. $\varnothing 4$ ) x 2 (Normal working pressure 0.8 MPa)
	Air tube (O.D. $\varnothing 4$ , I.D. $\varnothing 2.5$ ) x 2 (Normal working pressure 0.8 MPa)
Alarm indicator (Note 7)	Small red LED indicator x 1 (24 V DC must be supplied.)
Brake-release switch (Note 8)	Allows remote release of Z-axis (24 VDC required)

Ambient temperature/humidity	Temperature: 0-40 °C, humidity: 20-85%RH or less (no condensation)
Unit weight	T2: XSEL-PX/QX
Applicable controller	5L: 5 m (standard), 10L: 10 m (optional)

### Dimensions

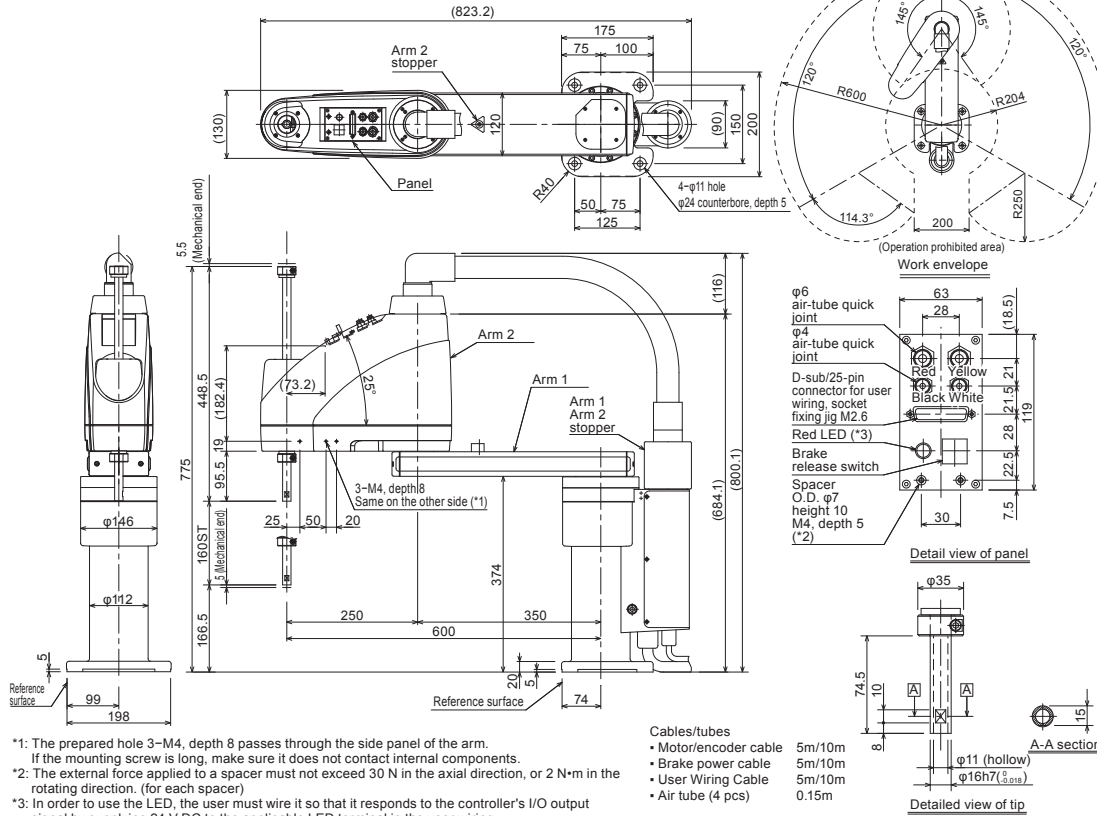

### Applicable Controller Specifications

Applicable Controller	Features	Maximum I/O points (inputs/outputs)	Power-supply voltage	Reference page
XSEL-PX	Controller dedicated to SCARA	192/192 points	Three-phase 200 V AC	p. 37
XSEL-QX	Safety Category 4 supported			

\*When operating the high-speed type, a PX/QX single-axis robot cannot be connected.



For explanations of (Note 1) through (Note 9), refer to page 6.

16

IX-NSN6016H

# IX-NNW2515H

Small SCARA robot, Dustproof/Splash-proof type  
Arm length 250mm, Vertical axis 150mm



<b>Model items</b>		<b>IX</b>	—	<b>NNW2515H</b>	—	<b>T2</b>
Series	Type	Cable length	Applicable controller			
Dustproof/Splash-proof type	Arm length 250mm, Vertical axis 150mm	5L : 5 m (standard) 10L: 10 m	T2: XSEL-PX/QX			

\*For details on the model items, refer to page 8.

### Model/Specifications

Model	Axis configuration		Arm length (mm)	Motor capacity (W)	Work envelope	Positioning Repeatability (mm) (Note 1)	PTP operation Maximum operating speed (Note 2)	Standard cycle time (sec) (Note 3)	Load capacity (kg) (Note 4)		Axis 3 (vertical axis) push force (N) (Note 5)		Axis 4 allowable load	
	Rated	Maximum							Maximum limit	Minimum limit	Allowable inertial moment (kg·m <sup>2</sup> ) (Note 6)	Allowable torque (N·m)		
IX-NNW2515H-□-T2	Axis 1	Arm 1	125	200	±120°	±0.010 (XY)	3191mm/s (Composite speed)	0.45	1	3	111.0	58.0	0.015	1.9
	Axis 2	Arm 2	125	100	±120°									
	Axis 3	Vertical axis	-	100	150mm	±0.010	1316mm/s							
	Axis 4	Rotating axis	-	50	±360°	±0.005	1600°/s							

\*In the model number above, specify the cable length in □.

\*SCARA robots cannot operate continuously at 100% speed and acceleration. For details on the operating conditions, refer to Reference Acceleration/Deceleration Settings on page 45.

### Common Specifications

Encoder type	Absolute
User wiring	15-conductor AWG26 waterproof connector with shield
User tubing	Air tube (O.D. $\phi$ 4, I.D. $\phi$ 2.5) x 3 (Normal working pressure 0.8 MPa)
Alarm indicator (Note 7)	Small red LED indicator x 1 (24 V DC must be supplied.)
Brake-release switch (Note 8)	Allows remote release of Z-axis (24 VDC required)

Ambient temperature/humidity	Temperature: 0-40 °C, humidity: 20-85%RH or less (no condensation)
Unit weight	21Kg
Applicable controller	T2: XSEL-PX/QX
Cable length (Note 9)	5L: 5 m (standard), 10L: 10 m (optional)
Protective structure	IP65 or equivalent
Air purge pressure (Note 10)	0.3 MPa or more (0.6 MPa maximum) (Clean, dry air)

### Dimensions

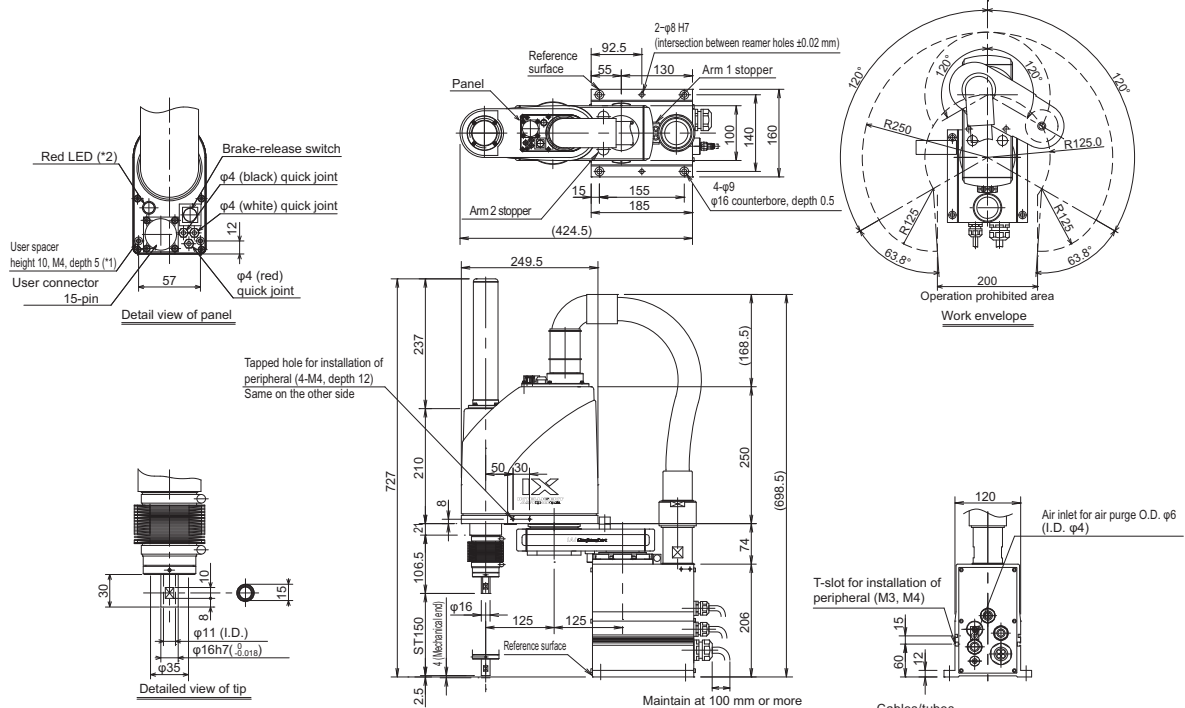

\*1: The external force applied to a spacer must not exceed 30 N in the axial direction, or 2 N·m in the rotating direction. (for each spacer)  
\*2: In order to use the LED, the user must wire it so that it responds to the controller's I/O output signal by supplying 24 V DC to the applicable LED terminal in the user wiring.

- Cables/tubes
- Motor/encoder cable 5m/10m
  - Brake power cable 5m/10m
  - User Wiring Cable 5m/10m
  - Air tube (4 pcs) 0.15m

### Applicable Controller Specifications

Applicable Controller	Features	Maximum I/O points (inputs/outputs)	Power-supply voltage	Reference page
XSEL-PX	Maximum 6 axes, 2400 W supported	192/192 points	Three-phase 200 V AC	p. 37
XSEL-QX	Safety Category 4 supported			



For explanations of (Note 1) through (Note 9), refer to page 6.  
(Note 10) Increase the air purge pressure to a range between 0.3 and 0.6 MPa until immediately before the bellows starts to inflate, and adjust the flow rate using the speed controller.  
As a purge medium, use clean, dry air free from compressor oil or other contaminants, conforming to an air filtration rating of 10  $\mu$ m or less.

# IX-NNW3515H

Small SCARA robot, Dustproof/Splash-proof type  
Arm length 350mm, Vertical axis 150mm



■ Model items <b>IX — NNW3515H</b> — <span style="border: 1px solid black; padding: 0 2px;"> </span> — <b>T2</b>			
Series	Type	Cable length	Applicable controller
Dustproof/Splash-proof type		5L : 5 m (standard) 10L: 10 m	T2: XSEL-PX/QX
Arm length 350mm, Vertical axis 150mm			

\*For details on the model items, refer to page 8.

### Model/Specifications

Model	Axis configuration	Arm length (mm)	Motor capacity (W)	Work envelope	Positioning Repeatability (mm) (Note 1)	PTP operation Maximum operating speed (Note 2)	Standard cycle time (sec) (Note 3)	Load capacity (kg) (Note 4)		Axis 3 (vertical axis) push force (N) (Note 5)		Axis 4 allowable load	
								Rated	Maximum	Maximum limit	Minimum limit	Allowable inertial moment (kg·m <sup>2</sup> ) (Note 6)	Allowable torque (N·m)
IX-NNW3515H- <span style="border: 1px solid black; padding: 0 2px;"> </span> -T2	Axis 1 Arm 1	225	200	±120°	±0.010 (XY)	4042mm/s (Composite speed)	0.47	1	3	111.0	58.0	0.015	1.9
	Axis 2 Arm 2	125	100	±135°									
	Axis 3 Vertical axis	-	100	150mm	±0.010	1316mm/s							
	Axis 4 Rotating axis	-	50	±360°	±0.005	1600°/s							

\*In the model number above, specify the cable length in  .

\*SCARA robots cannot operate continuously at 100% speed and acceleration. For details on the operating conditions, refer to Reference Acceleration/Deceleration Settings on page 45.

### Common Specifications

Encoder type	Absolute
User wiring	15-conductor AWG26 waterproof connector with shield
User tubing	Air tube (O.D. $\phi$ 4, I.D. $\phi$ 2.5) x 3 (Normal working pressure 0.8 MPa)
Alarm indicator (Note 7)	Small red LED indicator x 1 (24 V DC must be supplied.)
Brake-release switch (Note 8)	Allows remote release of Z-axis (24 VDC required)

Ambient temperature/humidity	Temperature: 0-40 °C, humidity: 20-85%RH or less (no condensation)
Unit weight	22Kg
Applicable controller	T2: XSEL-PX/QX
Cable length (Note 9)	5L: 5 m (standard), 10L: 10 m (optional)
Protective structure	IP65 or equivalent
Air purge pressure (Note 10)	0.3 MPa or more (0.6 MPa maximum) (Clean, dry air)

### Dimensions

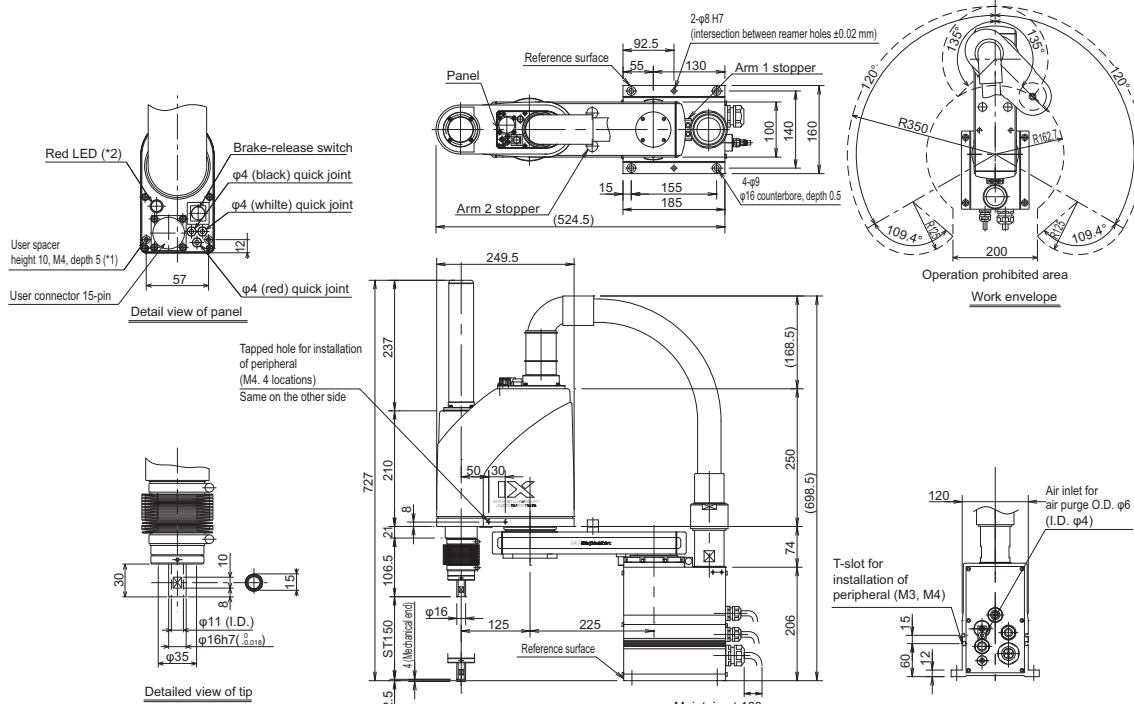

\*1: The external force applied to a spacer must not exceed 30 N in the axial direction, or 2 N·m in the rotating direction. (for each spacer)  
\*2: In order to use the LED, the user must wire it so that it responds to the controller's I/O output signal by supplying 24 V DC to the applicable LED terminal in the user wiring.

- Cables/tubes
- Motor/encoder cable 5m/10m
  - Brake power cable 5m/10m
  - User Wiring Cable 5m/10m
  - Air tube (4 pcs) 0.15m

### Applicable Controller Specifications

Applicable Controller	Features	Maximum I/O points (inputs/outputs)	Power-supply voltage	Reference page
XSEL-PX	Maximum 6 axes, 2400 W supported	192/192 points	Three-phase 200 V AC	p. 37
XSEL-QX	Safety Category 4 supported			



For explanations of (Note 1) through (Note 9), refer to page 6.  
(Note 10) Increase the air purge pressure to a range between 0.3 and 0.6 MPa until immediately before the bellows starts to inflate, and adjust the flow rate using the speed controller.  
As a purge medium, use clean, dry air free from compressor oil or other contaminants, conforming to an air filtration rating of 10 μm or less.

# IX-NNW50□□H

Medium SCARA robot, Dustproof/Splash-proof type  
Arm length 500mm, Vertical axis 200mm (300mm)



## Model items IX — NNW50□□H — □ — T2

Series	Type	Cable length	Applicable controller
NNW5020H: Arm length 500mm, Vertical axis 200mm		5L : 5 m (standard) 10L: 10 m	T2: XSEL-PX/QX
NNW5030H: Arm length 500mm, Vertical axis 300mm			

\*For details on the model items, refer to page 8.

### Model/Specifications

Model	Axis configuration		Arm length (mm)	Motor capacity (W)	Work envelope	Positioning Repeatability (mm) (Note 1)	PTP operation Maximum operating speed (Note 2)	Standard cycle time (sec) (Note 3)	Load capacity (kg) (Note 4)		Axis 3 (vertical axis) push force (N) (Note 5)		Axis 4 allowable load	
	Rated	Maximum							Maximum limit	Minimum limit	Allowable inertial moment (kg·m <sup>2</sup> ) (Note 6)	Allowable torque (N·m)		
IX-NNW5020H-□-T2 [IX-NNW5030H-□-T2]	Axis 1	Arm 1	250	400	±120°	±0.010 (XY)	6381mm/s (Composite speed)	0.43	2	10	181.0	93	0.06	3.7
	Axis 2	Arm 2	250	200	±145°									
	Axis 3	Vertical axis	-	200	200mm [300mm]	±0.010	1473mm/s							
	Axis 4	Rotating axis	-	100	±360°	±0.005	1857°/s							

\*In the model number above, specify the cable length in □.

\*SCARA robots cannot operate continuously at 100% speed and acceleration. For details on the operating conditions, refer to Reference Acceleration/Deceleration Settings on page 45.

### Common Specifications

Encoder type	Absolute
User wiring	23-conductor AWG26 waterproof connector with shield
User tubing	Air tube (O.D. $\varnothing$ 6, I.D. $\varnothing$ 4) x 2 (Normal working pressure 0.8 MPa) Air tube (O.D. $\varnothing$ 4, I.D. $\varnothing$ 2.5) x 2 (Normal working pressure 0.8 MPa)
Alarm indicator (Note 7)	Small red LED indicator x 1 (24 V DC must be supplied.)
Brake-release switch (Note 8)	Allows remote release of Z-axis (24 VDC required)

Ambient temperature/humidity	Temperature: 0-40 °C, humidity: 20-85%RH or less (no condensation)
Unit weight	32.5Kg
Applicable controller	T2: XSEL-PX/QX
Cable length (Note 9)	5L: 5 m (standard), 10L: 10 m (optional)
Protective structure	IP65 or equivalent
Air purge pressure (Note 10)	0.3 MPa or more (0.6 MPa maximum) (Clean, dry air)

### Dimensions

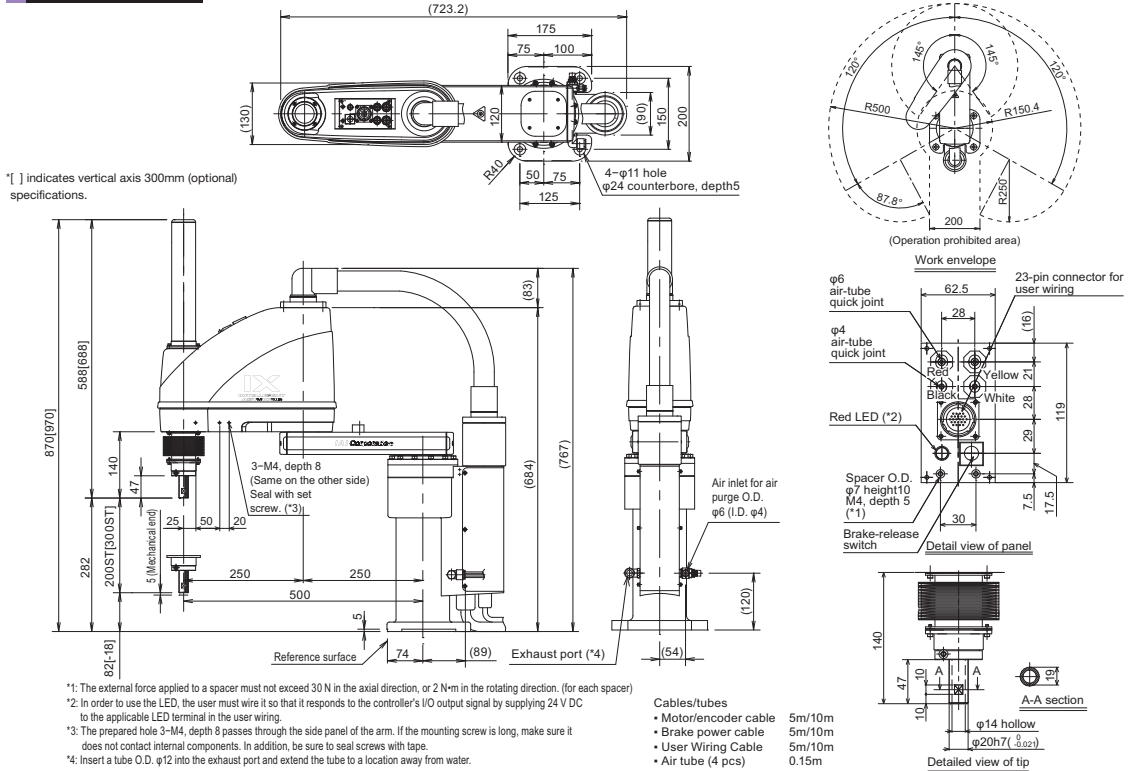

### Applicable Controller Specifications

Applicable Controller	Features	Maximum I/O points (inputs/outputs)	Power-supply voltage	Reference page
XSEL-PX	Maximum 6 axes, 2400 W supported	192/192 points	Three-phase 200 V AC	p. 37
XSEL-QX	Safety Category 4 supported			



For explanations of (Note 1) through (Note 9), refer to page 6.  
 (Note 10) Increase the air purge pressure to a range between 0.3 and 0.6 MPa until immediately before the bellows starts to inflate, and adjust the flow rate using the speed controller.  
 As a purge medium, use clean, dry air free from compressor oil or other contaminants, conforming to an air filtration rating of 10  $\mu$ m or less.

# IX-NNW60□□H

Medium SCARA robot, Dustproof/Splash-proof type  
Arm length 600mm, Vertical axis 200mm (300mm)



<b>Model items</b>	<b>IX</b>	<b>— NNW60□□H</b>	<b>□□</b>	<b>—</b>	<b>T2</b>
<b>Series</b>	<b>Type</b>		<b>Cable length</b>	<b>Applicable controller</b>	
NNW6020H: Arm length 600mm, Vertical axis 200mm			5L : 5 m (standard)	T2: XSEL-PX/QX	
NNW6030H: Arm length 600mm, Vertical axis 300mm			10L: 10 m		

\*For details on the model items, refer to page 8.

## Model/Specifications

Model	Axis configuration		Arm length (mm)	Motor capacity (W)	Work envelope	Positioning Repeatability (mm) (Note 1)	PTP operation Maximum operating speed (Note 2)	Standard cycle time (sec) (Note 3)	Load capacity (kg) (Note 4)		Axis 3 (vertical axis) push force (N) (Note 5)		Axis 4 allowable load	
	Rated	Maximum							Maximum limit	Minimum limit	Allowable inertial moment (kg·m <sup>2</sup> ) (Note 6)	Allowable torque (N·m)		
IX-NNW6020H-□-T2 [IX-NNW6030H-□-T2]	Axis 1	Arm 1	350	400	±120°	±0.010 (XY)	7232mm/s (Composite speed)	0.47	2	10	181.0	93	0.06	3.7
	Axis 2	Arm 2	250	200	±145°									
	Axis 3	Vertical axis	-	200	200mm [300mm]	±0.010	1393mm/s							
	Axis 4	Rotating axis	-	100	±360°	±0.005	1200°/s							

\*In the model number above, specify the cable length in □.

\*SCARA robots cannot operate continuously at 100% speed and acceleration. For details on the operating conditions, refer to Reference Acceleration/Deceleration Settings on page 45.

## Common Specifications

Encoder type	Absolute	Ambient temperature/humidity	Temperature: 0-40 °C, humidity: 20-85%RH or less (no condensation)
User wiring	23-conductor AWG26 waterproof connector with shield	Unit weight	34.5Kg
User tubing	Air tube (O.D. ø6, I.D. ø4) x 2 (Normal working pressure 0.8 MPa) Air tube (O.D. ø4, I.D. ø2.5) x 2 (Normal working pressure 0.8 MPa)	Applicable controller	T2: XSEL-PX/QX
Alarm indicator (Note 7)	Small red LED indicator x 1 (24 V DC must be supplied.)	Cable length (Note 9)	5L: 5 m (standard), 10L: 10 m (optional)
Brake-release switch (Note 8)	Allows remote release of Z-axis (24 VDC required)	Protective structure	IP65 or equivalent
		Air purge pressure (Note 10)	0.3 MPa or more (0.6 MPa maximum) (Clean, dry air)

## Dimensions

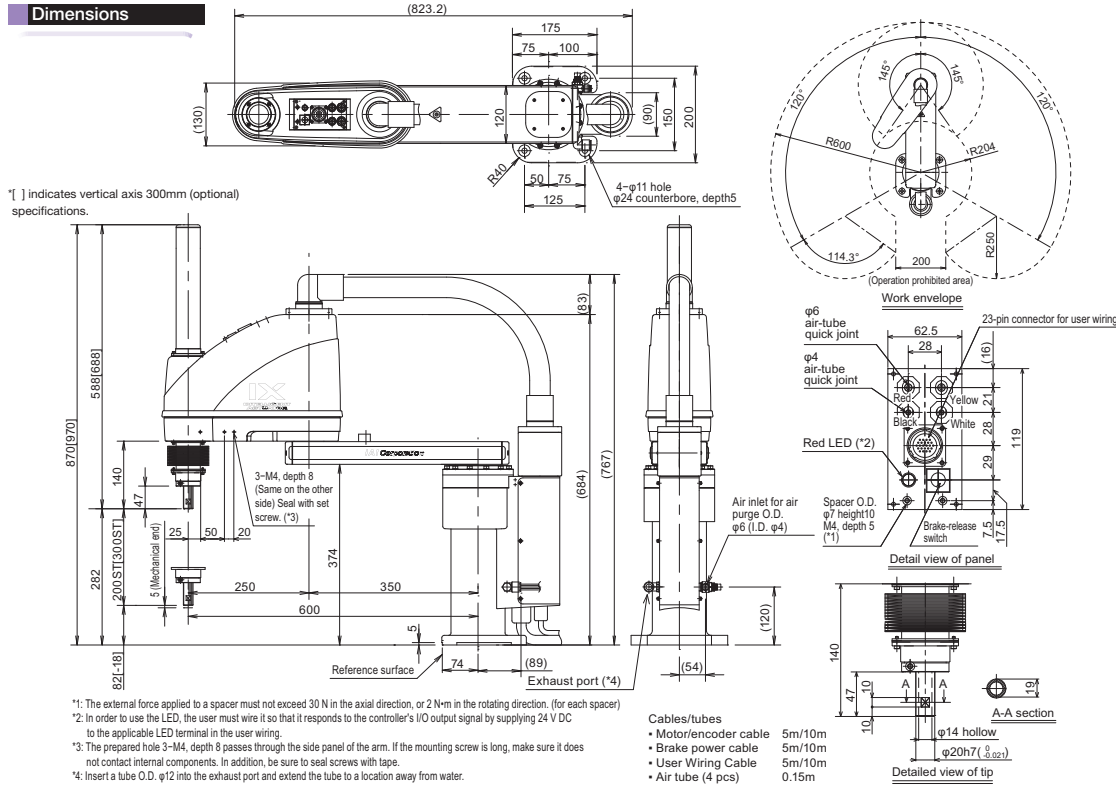

\*1: The external force applied to a spacer must not exceed 30 N in the axial direction, or 2 N·m in the rotating direction. (for each spacer)  
 \*2: In order to use the LED, the user must wire it so that it responds to the controller's I/O output signal by supplying 24 V DC to the applicable LED terminal in the user wiring.  
 \*3: The prepared hole 3-M4, depth 8 passes through the side panel of the arm. If the mounting screw is long, make sure it does not contact internal components. In addition, be sure to seal screws with tape.  
 \*4: Insert a tube O.D. φ12 into the exhaust port and extend the tube to a location away from water.

## Applicable Controller Specifications

Applicable Controller	Features	Maximum I/O points (inputs/outputs)	Power-supply voltage	Reference page
XSEL-PX	Maximum 6 axes, 2400 W supported	192/192 points	Three-phase 200 V AC	p. 37
XSEL-QX	Safety Category 4 supported			



Caution

For explanations of (Note 1) through (Note 9), refer to page 6.  
 (Note 10) Increase the air purge pressure to a range between 0.3 and 0.6 MPa until immediately before the bellows starts to inflate, and adjust the flow rate using the speed controller.  
 As a purge medium, use clean, dry air free from compressor oil or other contaminants, conforming to an air filtration rating of 10 μm or less.

# IX-NNW70□□H

Large SCARA robot, Dustproof/Splash-proof type  
Arm length 700mm, Vertical axis 200mm (400mm)



## Model items IX — NNW70□□H — □ — T2

Series	Type	Cable length	Applicable controller
NNW7020H: Arm length 700mm, Vertical axis 200mm		5L : 5 m (standard)	T2: XSEL-PX/QX
NNW7040H: Arm length 700mm, Vertical axis 400mm		10L : 10 m	

\*For details on the model items, refer to page 8.

### Model/Specifications

Model	Axis configuration	Arm length (mm)	Motor capacity (W)	Work envelope	Positioning Repeatability (mm) (Note 1)	PTP operation Maximum operating speed (Note 2)	Standard cycle time (sec) (Note 3)	Load capacity (kg) (Note 4)		Axis 3 (vertical axis) push force (N) (Note 5)		Axis 4 allowable load		
								Rated	Maximum	Maximum limit	Minimum limit	Allowable inertial moment (kg·m <sup>2</sup> ) (Note 6)	Allowable torque (N·m)	
IX-NNW7020H-□□-T2 [IX-NNW7040H-□□-T2]	Axis 1	Arm 1	350	750	±125°	7010mm/s (Composite speed)	0.45	5	20	304	146.0	0.1	11.7	
	Axis 2	Arm 2	350	400	±145°									
	Axis 3	Vertical axis	-	400	200mm [400mm]	±0.010								1614mm/s
	Axis 4	Rotating axis	-	200	±360°	±0.005								1266°/s

\*In the model number above, specify the cable length in □.

\*SCARA robots cannot operate continuously at 100% speed and acceleration. For details on the operating conditions, refer to Reference Acceleration/Deceleration Settings on page 46.

### Common Specifications

Encoder type	Absolute
User wiring	23-conductor AWG26 waterproof connector with shield
User tubing	Air tube (O.D. ϕ6, I.D. ϕ4) x 2 (Normal working pressure 0.8 MPa)
	Air tube (O.D. ϕ4, I.D. ϕ2.5) x 2 (Normal working pressure 0.8 MPa)
Alarm indicator (Note 7)	Small red LED indicator x 1 (24 V DC must be supplied.)
Brake-release switch (Note 8)	Allows remote release of Z-axis (24 VDC required)

Ambient temperature/humidity	Temperature: 0-40 °C, humidity: 20-85%RH or less (no condensation)
Unit weight	60Kg
Applicable controller	T1: XSEL-KX, T2: XSEL-PX/QX
Cable length (Note 9)	5L: 5 m (standard), 10L: 10 m (optional)
Protective structure	IP65 or equivalent
Air purge pressure (Note 10)	0.3 MPa or more (0.6 MPa maximum) (Clean, dry air)

### Dimensions

\* [ ] indicates vertical axis 400mm (optional) specifications.

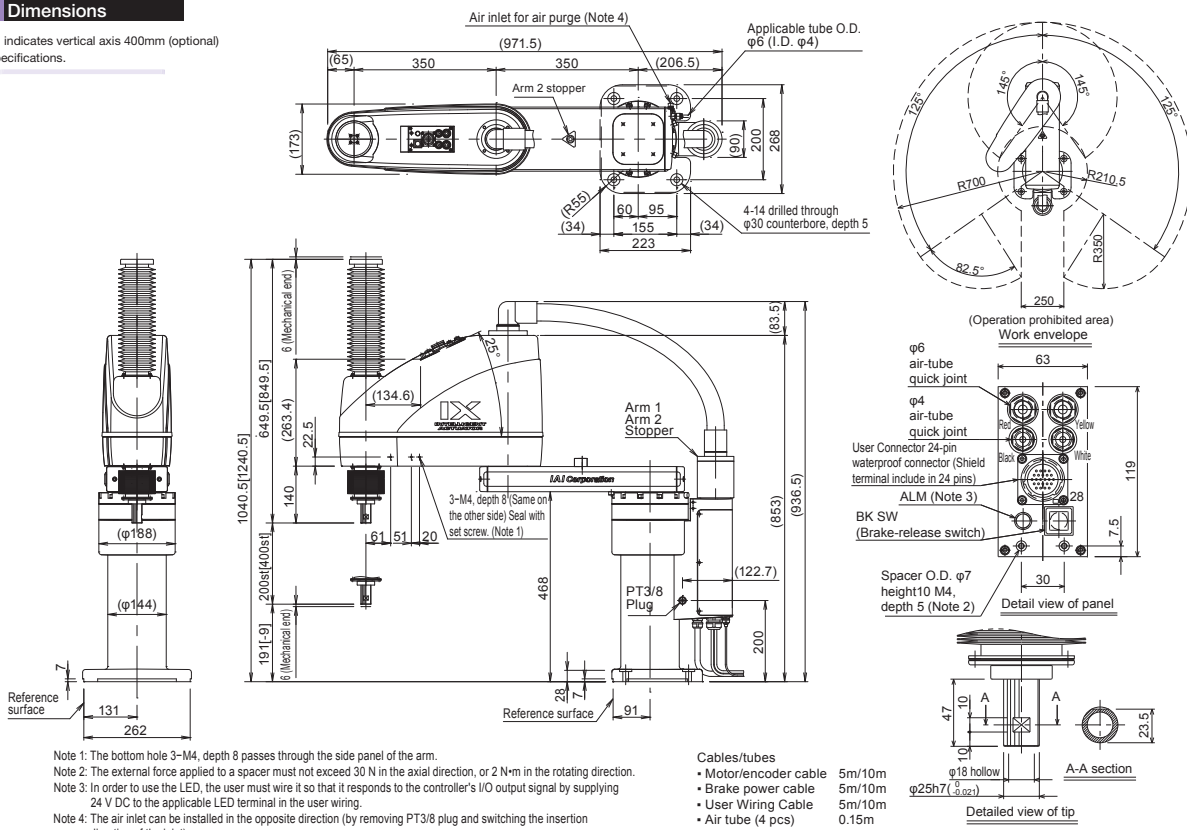

- Note 1: The bottom hole 3-M4, depth 8 passes through the side panel of the arm.
- Note 2: The external force applied to a spacer must not exceed 30 N in the axial direction, or 2 N·m in the rotating direction.
- Note 3: In order to use the LED, the user must wire it so that it responds to the controller's I/O output signal by supplying 24 V DC to the applicable LED terminal in the user wiring.
- Note 4: The air inlet can be installed in the opposite direction (by removing PT3/8 plug and switching the insertion direction of the joint).

### Applicable Controller Specifications

Applicable Controller	Features	Maximum I/O points (inputs/outputs)	Power-supply voltage	Reference page
XSEL-PX	Controller dedicated to SCARA	192/192 points	Three-phase 200 V AC	p. 37
XSEL-QX	Safety Category 4 supported			



Caution

For explanations of (Note 1) through (Note 9), refer to page 6.  
 (Note 10) Increase the air purge pressure to a range between 0.3 and 0.6 MPa until immediately before the bellows starts to inflate, and adjust the flow rate using the speed controller.  
 As a purge medium, use clean, dry air free from compressor oil or other contaminants, conforming to an air filtration rating of 10 μm or less.

# 21 IX-NNW70□□H

# IX-NNW80□□H

Large SCARA robot, Dustproof/Splash-proof type  
Arm length 800mm, Vertical axis 200mm (400mm)

SCARA

SCARA



## Model items IX — NNW80□□H — □ — T2

Series	Type	Cable length	Applicable controller
NNW8020H: Arm length 800mm, Vertical axis 200mm		5L : 5 m (standard) 10L: 10 m	T2: XSEL-PX/QX
NNW8040H: Arm length 800mm, Vertical axis 400mm			

\*For details on the model items, refer to page 8.

### Model/Specifications

Model	Axis configuration	Arm length (mm)	Motor capacity (W)	Work envelope	Positioning Repeatability (mm) (Note 1)	PTP operation Maximum operating speed (Note 2)	Standard cycle time (sec) (Note 3)	Load capacity (kg) (Note 4)		Axis 3 (vertical axis) push force (N) (Note 5)		Axis 4 allowable load		
								Rated		Maximum limit	Minimum limit	Allowable inertial moment (kg·m <sup>2</sup> ) (Note 6)	Allowable torque (N·m)	
IX-NNW8020H-□□-T2 [IX-NNW8040H-□□-T2]	Axis 1	Arm 1	450	750	±125°	7586mm/s (Composite speed)	0.46	5	20	304	146.0	0.1	11.7	
	Axis 2	Arm 2	350	400	±145°									
	Axis 3	Vertical axis	-	400	200mm [400mm]	±0.010								1614mm/s
	Axis 4	Rotating axis	-	200	±360°	±0.005								1266°/s

\*In the model number above, specify the cable length in □.

\*SCARA robots cannot operate continuously at 100% speed and acceleration. For details on the operating conditions, refer to Reference Acceleration/Deceleration Settings on page 46.

### Common Specifications

Encoder type	Absolute	Ambient temperature/humidity	Temperature: 0-40 °C, humidity: 20-85%RH or less (no condensation)
User wiring	23-conductor AWG26 waterproof connector with shield	Unit weight	62Kg
User tubing	Air tube (O.D. φ6, I.D. φ4) x 2 (Normal working pressure 0.8 MPa)	Applicable controller	T2: XSEL-PX/QX
	Air tube (O.D. φ4, I.D. φ.5) x 2 (Normal working pressure 0.8 MPa)	Cable length (Note 9)	5L: 5 m (standard), 10L: 10 m (optional)
Alarm indicator (Note 7)	Small red LED indicator x 1 (24 V DC must be supplied.)	Protective structure	IP65 or equivalent
Brake-release switch (Note 8)	Allows remote release of Z-axis (24 VDC required)	Air purge pressure (Note 10)	0.3 MPa or more (0.6 MPa maximum) (Clean, dry air)

### Dimensions

[ ] indicates vertical axis 400mm (optional) specifications.

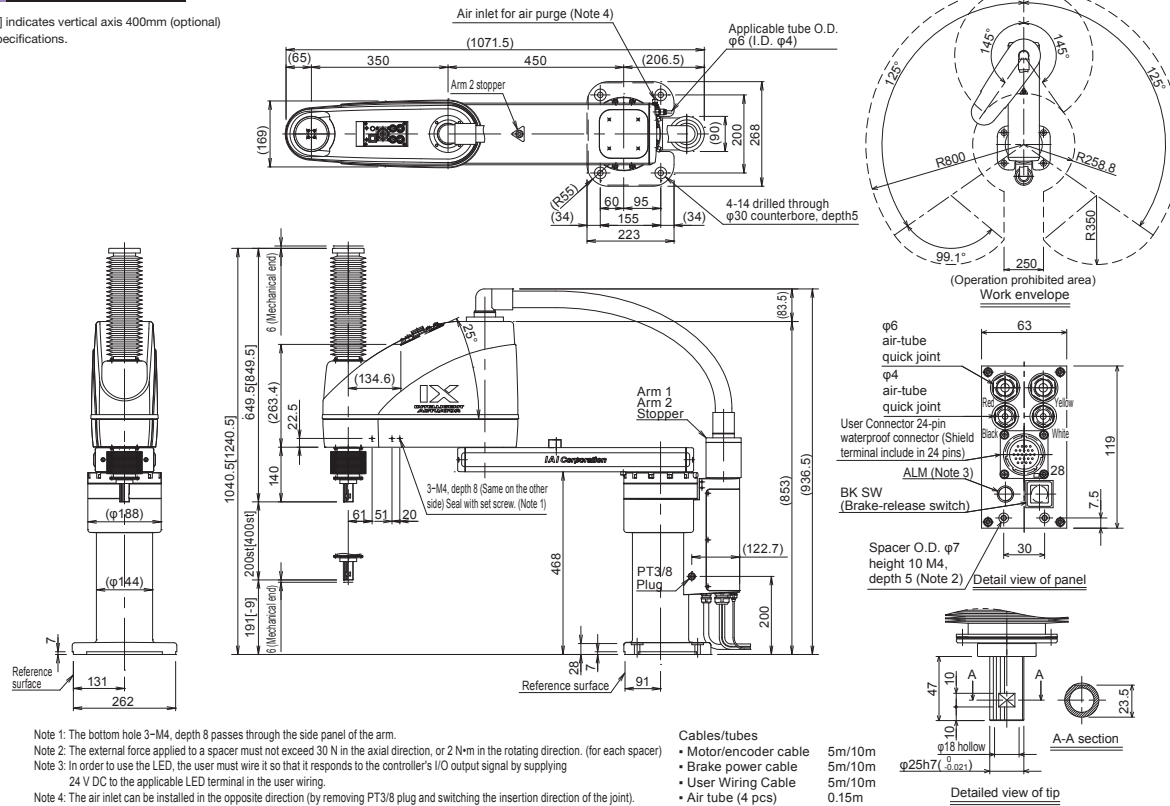

- Note 1: The bottom hole 3-M4, depth 8 passes through the side panel of the arm.  
 Note 2: The external force applied to a spacer must not exceed 30 N in the axial direction, or 2 N·m in the rotating direction. (for each spacer)  
 Note 3: In order to use the LED, the user must wire it so that it responds to the controller's I/O output signal by supplying 24 V DC to the applicable LED terminal in the user wiring.  
 Note 4: The air inlet can be installed in the opposite direction (by removing PT3/8 plug and switching the insertion direction of the joint).

- Cables/tubes
- Motor/encoder cable 5m/10m
  - Brake power cable 5m/10m
  - User Wiring Cable 5m/10m
  - Air tube (4 pcs) 0.15m

### Applicable Controller Specifications

Applicable Controller	Features	Maximum I/O points (inputs/outputs)	Power-supply voltage	Reference page
XSEL-PX	Controller dedicated to SCARA	192/192 points	Three-phase 200 V AC	p. 37
XSEL-QX	Safety Category 4 supported			

**Caution**

For explanations of (Note 1) through (Note 9), refer to page 6.  
 (Note 10) Increase the air purge pressure to a range between 0.3 and 0.6 MPa until immediately before the bellows starts to inflate, and adjust the flow rate using the speed controller.  
 As a purge medium, use clean, dry air free from compressor oil or other contaminants, conforming to an air filtration rating of 10 μm or less.

IX-NNW80□□H **22**

<b>IX-TNN3015H</b>	Small SCARA robot, Wall-mount type Arm length 300mm, Vertical axis 150mm
<b>IX-UNN3015H</b>	Small SCARA robot, Wall-mount inverse type Arm length 300mm, Vertical axis 150mm

■ Model items
IX
□ NN3015H
—
—
—
—
T2

Series	Type	Cable length	Applicable controller
TNN3015H : Wall-mount type Arm length 300mm, Vertical axis 150mm	UNN3015H : Wall-mount inverse type Arm length 300mm, Vertical axis 150mm	5L : 5 m (standard) 10L: 10 m	T2: XSEL-PX/QX



\*For details on the model items, refer to page 8.

**Model/Specifications**

Model	Axis configuration		Arm length (mm)	Motor capacity (W)	Work envelope	Positioning Repeatability (mm) (Note 1)	PTP operation Maximum operating speed (Note 2)	Standard cycle time (sec) (Note 3)	Load capacity (kg) (Note 4)		Axis 3 (vertical axis) push force (N) (Note 5)		Axis 4 allowable load	
	Rated	Maximum							Maximum limit	Minimum limit	Allowable inertial moment (kg·m <sup>2</sup> ) (Note 6)	Allowable torque (N·m)		
IX-TNN3015H-□-T2 IX-UNN3015H-□-T2	Axis 1	Arm 1	175	200	±120°	±0.010 (XY)	3616mm/s (Composite speed)	0.41	1	3	111.0	58.0	0.015	1.9
	Axis 2	Arm 2	125	100	±130°		1316mm/s							
	Axis 3	Vertical axis	-	100	150mm	±0.010	1600°/s							
	Axis 4	Rotating axis	-	50	±360°	±0.005								

\*In the model number above, specify the cable length in □.

\*SCARA robots cannot operate continuously at 100% speed and acceleration. For details on the operating conditions, refer to Reference Acceleration/Deceleration Settings on page 45.

**Common Specifications**

Encoder type	Absolute
User wiring	15-conductor AWG26 D-sub/15-pin connector with shield (socket)
User tubing	Air tube (O.D. φ4, I.D. φ2.5) x 3 (Normal working pressure 0.8 MPa)
Alarm indicator (Note 7)	Small red LED indicator x 1 (24 V DC must be supplied.)
Brake-release switch (Note 8)	Allows remote release of Z-axis (24 VDC required)

Ambient temperature/humidity	Temperature: 0–40 °C, humidity: 20–85%RH or less (no condensation)
Unit weight	20.8Kg
Applicable controller	T2: XSEL-PX/QX
Cable length (Note 9)	5L: 5 m (standard), 10L: 10 m (optional)

**Dimensions**

\*For the inverse type, the following illustrations should be turned upside down. (See page 2.)

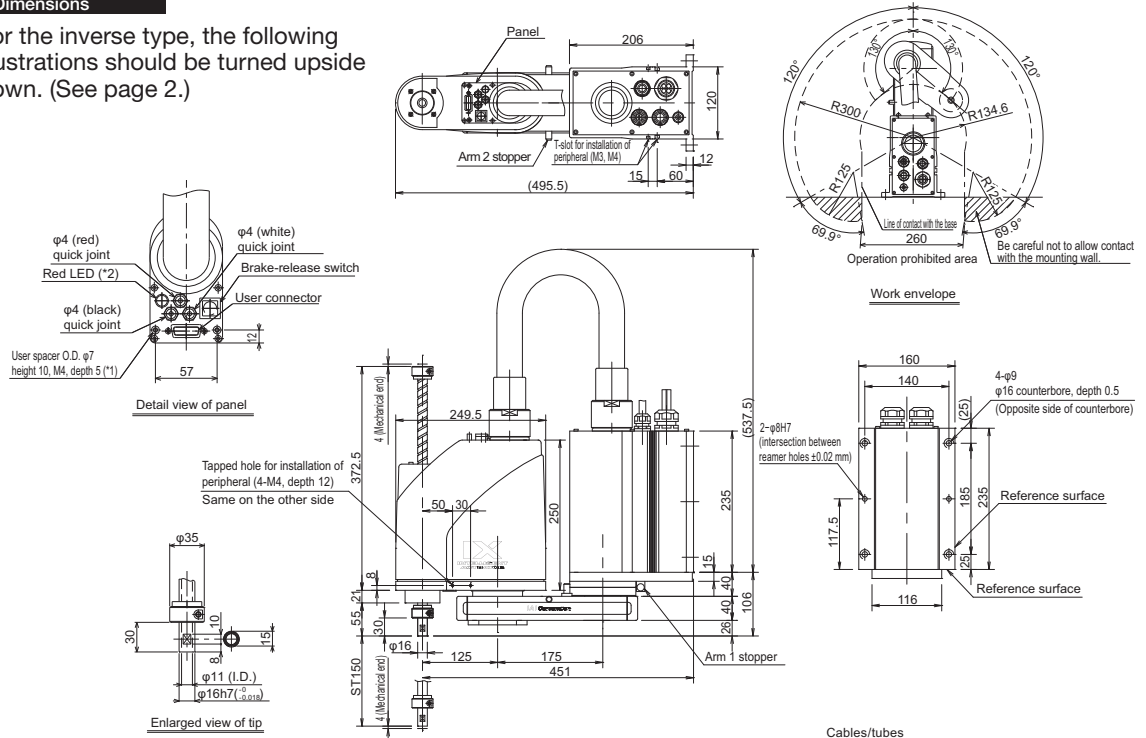

\*1: The external force applied to a spacer must not exceed 30 N in the axial direction, or 2 N·m in the rotating direction. (for each spacer)  
 \*2: In order to use the LED, the user must wire it so that it responds to the controller's I/O output signal by supplying 24 V DC to the applicable LED terminal in the user wiring.

**Applicable Controller Specifications**

Applicable Controller	Features	Maximum I/O points (inputs/outputs)	Power-supply voltage	Reference page
XSEL-PX	Maximum 6 axes, 2400 W supported	192/192 points	Three-phase 200 V AC	p. 37
XSEL-QX	Safety Category 4 supported			

⚠ Caution

For explanations of (Note 1) through (Note 9), refer to page 6.



# IX-TNN3515H

Small SCARA robot, Wall-mount type  
Arm length 350mm, Vertical axis 150mm

# IX-UNN3515H

Small SCARA robot, Wall-mount inverse type  
Arm length 350mm, Vertical axis 150mm

■ Model items IX — □ NN3515H — □ — T2

Series	Type	Cable length	Applicable controller
TNN3515H : Wall-mount type Arm length 350mm, Vertical axis 150mm	5L : 5 m (standard) 10L : 10 m	T2: XSEL-PX/QX	
UNN3515H : Wall-mount inverse type Arm length 350mm, Vertical axis 150mm			



\*For details on the model items, refer to page 8.

## Model/Specifications

Model	Axis configuration		Arm length (mm)	Motor capacity (W)	Work envelope	Positioning Repeatability (mm) (Note 1)	PTP operation Maximum operating speed (Note 2)	Standard cycle time (sec) (Note 3)	Load capacity (kg) (Note 4)		Axis 3 (vertical axis) push force (N) (Note 5)		Axis 4 allowable load	
	Rated	Maximum							Maximum limit	Minimum limit	Allowable inertial moment (kg-m <sup>2</sup> ) (Note 6)	Allowable torque (N · m)		
IX-TNN3515H-□]-T2 IX-UNN3515H-□]-T2	Axis 1	Arm 1	225	200	±120°	±0.010 (XY)	4042mm/s (Composite speed) 1316mm/s 1600°/s	0.42	1	3	111.0	58.0	0.015	1.9
	Axis 2	Arm 2	125	100	±135°									
	Axis 3	Vertical axis	-	100	150mm	±0.010								
	Axis 4	Rotating axis	-	50	±360°	±0.005								

\*In the model number above, specify the cable length in □.

\*SCARA robots cannot operate continuously at 100% speed and acceleration. For details on the operating conditions, refer to Reference Acceleration/Deceleration Settings on page 45.

## Common Specifications

Encoder type	Absolute
User wiring	15-conductor AWG26 D-sub/15-pin connector with shield (socket)
User tubing	Air tube (O.D. $\phi 4$ , I.D. $\phi 2.5$ ) x 3 (Normal working pressure 0.8 MPa)
Alarm indicator (Note 7)	Small red LED indicator x 1 (24 V DC must be supplied.)
Brake-release switch (Note 8)	Allows remote release of Z-axis (24 VDC required)

Ambient temperature/humidity	Temperature: 0-40 °C, humidity: 20-85%RH or less (no condensation)
Unit weight	21.9Kg
Applicable controller	T2: XSEL-PX/QX
Cable length (Note 9)	5L: 5 m (standard), 10L: 10 m (optional)

## Dimensions

\*For the inverse type, the following illustrations should be turned upside down. (See page 2.)

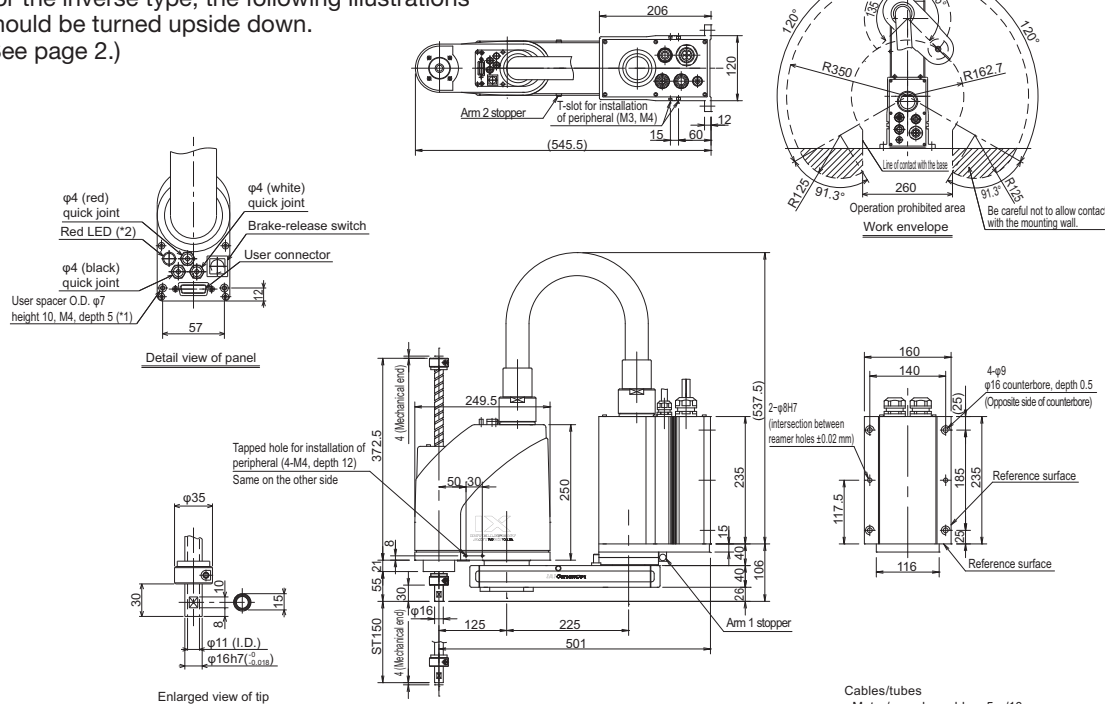

- \*1: The external force applied to a spacer must not exceed 30 N in the axial direction, or 2 N·m in the rotating direction. (for each spacer)  
\*2: In order to use the LED, the user must wire it so that it responds to the controller's I/O output signal by supplying 24 V DC to the applicable LED terminal in the user wiring.

## Applicable Controller Specifications

Applicable Controller	Features	Maximum I/O points (inputs/outputs)	Power-supply voltage	Reference page
XSEL-PX	Maximum 6 axes, 2400 W supported	192/192 points	Three-phase 200 V AC	p. 37
XSEL-QX	Safety Category 4 supported			

 <b>Caution</b>	For explanations of (Note 1) through (Note 9), refer to page 6.
--------------------	---

Sold & Serviced By:

**ELECTROMATE**

Toll Free Phone (877) SERV098

Toll Free Fax (877) SERV099

www.electromate.com

sales@electromate.com

IX-TNN3515H/IX-UNN3515H **24**

# IX-HNN5020H

Medium SCARA robot, Ceiling-mount type, Arm length 500mm  
Vertical axis 200mm

# IX-INN5020H

Medium SCARA robot, Inverse type, Arm length 500mm  
Vertical axis 200mm

■ Model items **IX** — □ **NN5020H** — □ — **T2**

Series	Type	Cable length	Applicable controller
HNN5020H : Ceiling-mount type Arm length 500mm, Vertical axis 200mm		5L : 5 m (standard) 10L : 10 m	T2: XSEL-PX/QX
INN5020H : Inverse type Arm length 500mm, Vertical axis 200mm			



\*For details on the model items, refer to page 8.

## Model/Specifications

Model	Axis configuration		Arm length (mm)	Motor capacity (W)	Work envelope	Positioning Repeatability (mm) (Note 1)	PTP operation Maximum operating speed (Note 2)	Standard cycle time (sec) (Note 3)	Load capacity (kg) (Note 4)		Axis 3 (vertical axis) push force (N) (Note 5)		Axis 4 allowable load	
	Rated	Maximum							Maximum limit	Minimum limit	Allowable inertial moment (kg·m <sup>2</sup> ) (Note 6)	Allowable torque (N·m)		
IX-HNN5020H-□-T2 IX-INN5020H-□-T2	Axis 1	Arm 1	250	400	±120°	±0.010 (XY)	6381mm/s (Composite speed)	0.39	2	10	181.0	93	0.06	3.7
	Axis 2	Arm 2	250	200	±135°									
	Axis 3	Vertical axis	-	200	200mm	±0.010	1473mm/s							
	Axis 4	Rotating axis	-	100	±360°	±0.005	1857°/s							

\*In the model number above, specify the cable length in □.

\*SCARA robots cannot operate continuously at 100% speed and acceleration. For details on the operating conditions, refer to Reference Acceleration/Deceleration Settings on page 45.

## Common Specifications

Encoder type	Absolute
User wiring	25-conductor AWG26 D-sub/25-pin connector with shield (socket)
User tubing	Air tube (O.D. $\phi 6$ , I.D. $\phi 4$ ) x 2 (Normal working pressure 0.8 MPa)
	Air tube (O.D. $\phi 4$ , I.D. $\phi 2.5$ ) x 2 (Normal working pressure 0.8 MPa)
Alarm indicator (Note 7)	Small red LED indicator x 1 (24 V DC must be supplied.)
Brake-release switch (Note 8)	Allows remote release of Z-axis (24 VDC required)

Ambient temperature/humidity	Temperature: 0–40 °C, humidity: 20–85%RH or less (no condensation)
Unit weight	30.5Kg
Applicable controller	T2: XSEL-PX/QX
Cable length (Note 9)	5L: 5 m (standard), 10L: 10 m (optional)

## Dimensions

\*For the inverse type, the following illustrations should be turned upside down. (See page 2.)

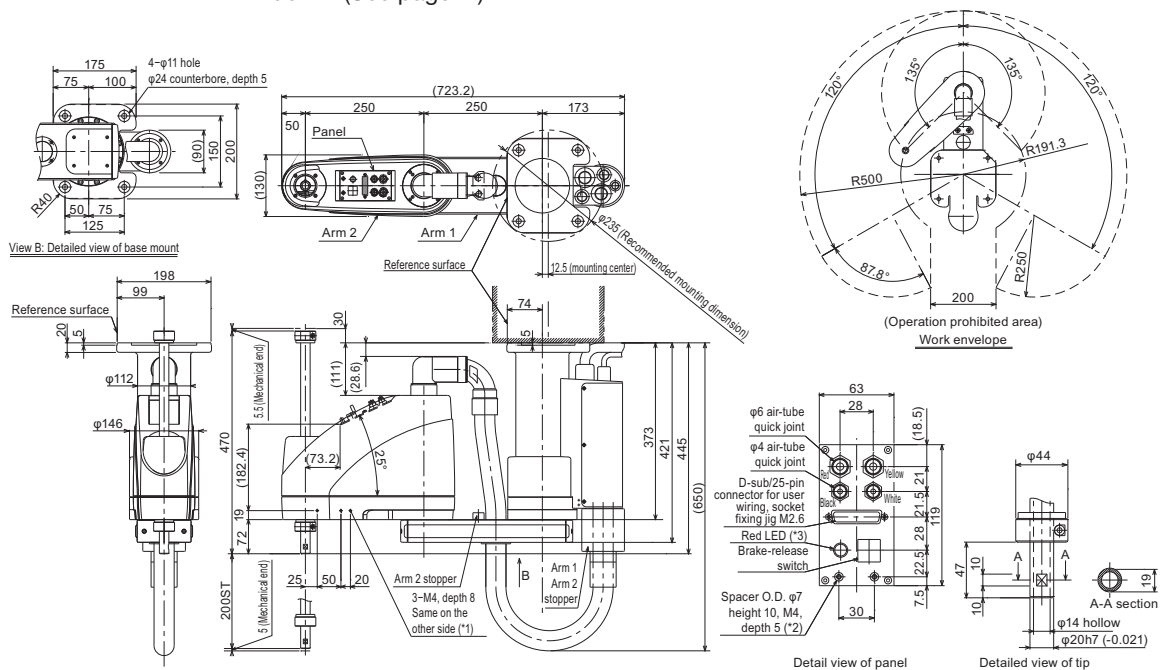

\*1: The prepared hole 3–M4, depth 8 passes through the side panel of the arm. If the mounting screw is long, make sure it does not contact internal components.

\*2: The external force applied to a spacer must not exceed 30 N in the axial direction, or 2 N·m in the rotating direction. (for each spacer)

\*3: In order to use the LED, the user must wire it so that it responds to the controller's I/O output signal by supplying 24 V DC to the applicable LED terminal in the user wiring.

- Cables/tubes
- Motor/encoder cable 5m/10m
- Brake power cable 5m/10m
- User Wiring Cable 5m/10m
- Air tube (4 pcs) 0.15m

## Applicable Controller Specifications

Applicable Controller	Features	Maximum I/O points (inputs/outputs)	Power-supply voltage	Reference page
XSEL-PX	Maximum 6 axes, 2400 W supported	192/192 points	Three-phase 200 V AC	p. 37
XSEL-QX	Safety Category 4 supported			



For explanations of (Note 1) through (Note 9), refer to page 6.

# 25

IX-HNN5020H/IX-INN5020H

Sold & Serviced By:

**ELECTROMATE**

Toll Free Phone (877) SERV098

Toll Free Fax (877) SERV099

www.electromate.com

sales@electromate.com

# IX-HNN6020H

Medium SCARA robot, Ceiling-mount type, Arm length 600mm  
Vertical axis 200mm

# IX-INN6020H

Medium SCARA robot, Inverse type, Arm length 600mm  
Vertical axis 200mm



Model items	IX	□	NN6020H	□	T2
Series	Type		Cable length	Applicable controller	
HNN6020H : Ceiling-mount type	INN6020H : Inverse type		5L : 5 m (standard)	T2: XSEL-PX/QX	
Arm length 600mm, Vertical axis 200mm	Arm length 600mm, Vertical axis 200mm		10L: 10 m		

\*For details on the model items, refer to page 8.

### Model/Specifications

Model	Axis configuration		Arm length (mm)	Motor capacity (W)	Work envelope	Positioning Repeatability (mm) (Note 1)	PTP operation Maximum operating speed (Note 2)	Standard cycle time (sec) (Note 3)	Load capacity (kg) (Note 4)		Axis 3 (vertical axis) push force (N) (Note 5)		Axis 4 allowable load	
	Axis 1	Axis 2							Rated	Maximum	Maximum limit	Minimum limit	Allowable inertial moment (kg·m <sup>2</sup> ) (Note 6)	Allowable torque (N·m)
IX-HNN6020H-□-T2 IX-INN6020H-□-T2	Axis 1	Arm 1	350	400	±120°	±0.010 (XY)	7232mm/s (Composite speed)	0.43	2	10	181.0	93	0.06	3.7
	Axis 2	Arm 2	250	200	±145°		1473mm/s							
	Axis 3	Vertical axis	-	200	200mm	±0.010	1857°/s							
	Axis 4	Rotating axis	-	100	±360°	±0.005								

\*In the model number above, specify the cable length in □.

\*SCARA robots cannot operate continuously at 100% speed and acceleration. For details on the operating conditions, refer to Reference Acceleration/Deceleration Settings on page 45.

### Common Specifications

Encoder type	Absolute
User wiring	25-conductor AWG26 D-sub/25-pin connector with shield (socket)
User tubing	Air tube (O.D. $\phi 6$ , I.D. $\phi 4$ ) x 2 (Normal working pressure 0.8 MPa)
	Air tube (O.D. $\phi 4$ , I.D. $\phi 2.5$ ) x 2 (Normal working pressure 0.8 MPa)
Alarm indicator (Note 7)	Small red LED indicator x 1 (24 V DC must be supplied.)
Brake-release switch (Note 8)	Allows remote release of Z-axis (24 VDC required)

Ambient temperature/humidity	Temperature: 0-40 °C, humidity: 20-85%RH or less (no condensation)
Unit weight	31.5Kg
Applicable controller	T2: XSEL-PX/QX
Cable length (Note 9)	5L: 5 m (standard), 10L: 10 m (optional)

### Dimensions

\*For the inverse type, the following illustrations should be turned upside down. (See page 2.)

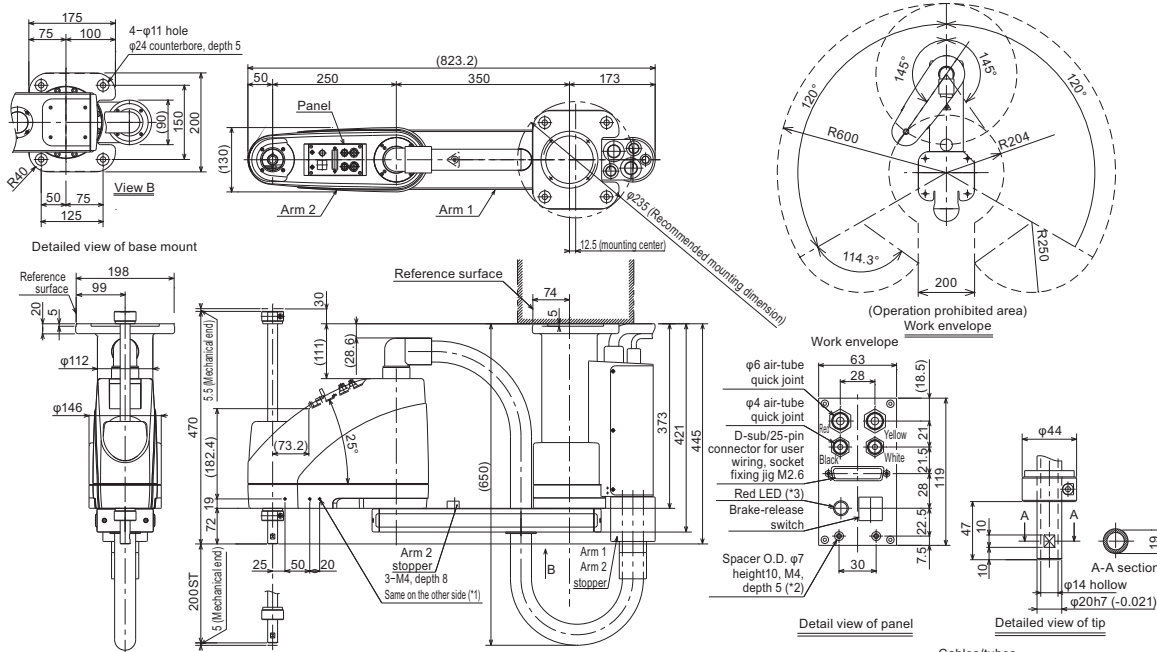

\*1: The prepared hole 3-M4, depth 8 passes through the side panel of the arm. If the mounting screw is long, make sure it does not contact internal components.  
\*2: The external force applied to a spacer must not exceed 30 N in the axial direction, or 2 N·m in the rotating direction. (for each spacer)  
\*3: In order to use the LED, the user must wire it so that it responds to the controller's I/O output signal by supplying 24 V DC to the applicable LED terminal in the user wiring.

- Cables/tubes
- Motor/encoder cable 5m/10m
  - Brake power cable 5m/10m
  - User Wiring Cable 5m/10m
  - Air tube (4 pcs) 0.15m

### Applicable Controller Specifications

Applicable Controller	Features	Maximum I/O points (inputs/outputs)	Power-supply voltage	Reference page
XSEL-PX	Maximum 6 axes, 2400 W supported	192/192 points	Three-phase 200 V AC	p. 37
XSEL-QX	Safety Category 4 supported			

**Caution** For explanations of (Note 1) through (Note 9), refer to page 6.

# IX-HNN70□□H

Large SCARA robot, Ceiling-mount type, Arm length 700mm  
Vertical axis 200mm (400mm)

# IX-INN70□□H

Large SCARA robot, Inverse type, Arm length 700mm  
Vertical axis 200mm (400mm)

■Model items **IX** — □NN70□□H — □ — **T2**

Series	Type	Cable length	Applicable controller
HNN7020(7040)H: Ceiling-mount type		5L : 5 m (standard)	T2: XSEL-PX/QX
Arm length 700mm, Vertical axis 200mm (400mm)		10L: 10 m	
INN7020(7040)H: Inverse type			
Arm length 700mm, Vertical axis 200mm (400mm)			



\*For details on the model items, refer to page 8.

### Model/Specifications

Model	Axis configuration		Arm length (mm)	Motor capacity (W)	Work envelope	Positioning Repeatability (mm) (Note 1)	PTP operation Maximum operating speed (Note 2)	Standard cycle time (sec) (Note 3)	Load capacity (kg) (Note 4)		Axis 3 (vertical axis) push force (N) (Note 5)		Axis 4 allowable load	
									Rated	Maximum	Maximum limit	Minimum limit	Allowable inertial moment (kg·m <sup>2</sup> ) (Note 6)	Allowable torque (N·m)
IX-HNN7020H-□-T2 [IX-HNN7040H-□-T2]	Axis 1	Arm 1	350	750	±125°	±0.015 (XY)	7010mm/s (Composite speed)	0.42	5	20	304	146.0	0.1	11.7
	Axis 2	Arm 2	350	400	±145°									
IX-INN7020H-□-T2 [IX-INN7040H-□-T2]	Axis 3	Vertical axis	-	400	200mm [400mm]	±0.010	1614mm/s							
	Axis 4	Rotating axis	-	100	±360°	±0.005	1266°/s							

\*In the model number above, specify the cable length in □.

\*SCARA robots cannot operate continuously at 100% speed and acceleration. For details on the operating conditions, refer to Reference Acceleration/Deceleration Settings on page 46.

### Common Specifications

Encoder type	Absolute
User wiring	25-conductor AWG26 D-sub/25-pin connector with shield (socket)
User tubing	Air tube (O.D. ø6, I.D. ø4) x 2 (Normal working pressure 0.8 MPa) Air tube (O.D. ø4, I.D. ø2.5) x 2 (Normal working pressure 0.8 MPa)
Alarm indicator (Note 7)	Small red LED indicator x 1 (24 V DC must be supplied.)
Brake-release switch (Note 8)	Allows remote release of Z-axis (24 VDC required)

Ambient temperature/humidity	Temperature: 0-40 °C, humidity: 20-85%RH or less (no condensation)
Unit weight	58Kg
Applicable controller	T2: XSEL-PX/QX
Cable length (Note 9)	5L: 5 m (standard), 10L: 10 m (optional)

### Dimensions

\*For the inverse type, the following illustrations should be turned upside down. (See page 2.)

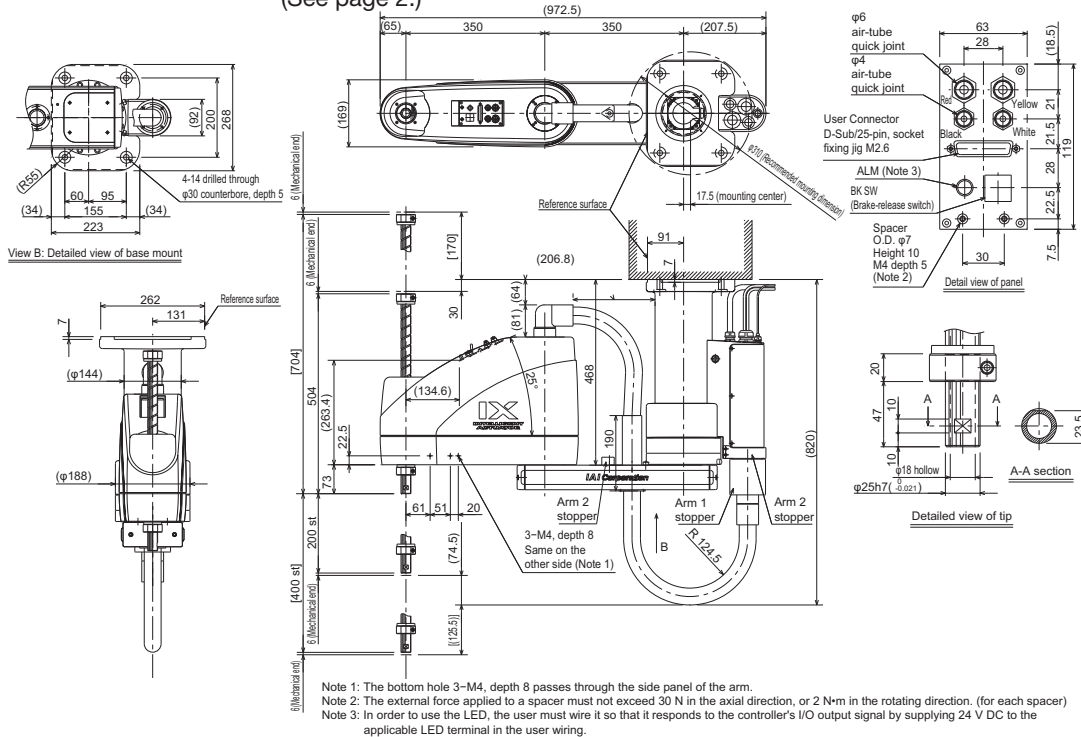

[ ] indicates vertical axis 400mm (optional) specifications.

### Applicable Controller Specifications

Applicable Controller	Features	Maximum I/O points (inputs/outputs)	Power-supply voltage	Reference page
XSEL-PX	Maximum 5 axes, 2400 W supported	192/192 points	Three-phase 200 V AC	p. 37
XSEL-QX	Safety Category 4 supported			



For explanations of (Note 1) through (Note 9), refer to page 6.

# 27

IX-HNN70□□H/IX-INN70□□H

Sold & Serviced By:

**ELECTROMATE**

Toll Free Phone (877) SERV098

Toll Free Fax (877) SERV099

www.electromate.com

sales@electromate.com

**IX-HNN80□□H**Large SCARA robot, Ceiling-mount type, Arm length 800mm  
Vertical axis 200mm (400mm)**IX-INN80□□H**Large SCARA robot, Inverse type, Arm length 800mm  
Vertical axis 200mm (400mm)■ Model items **IX — □NN80□□H — □ — T2**

Series	Type	Cable length	Applicable controller
HNN8020(8040)H	Ceiling-mount type	5L : 5 m (standard)	T2: XSEL-PX/QX
HNN8020(8040)H	Inverse type	10L: 10 m	
HNN8020(8040)H			
HNN8020(8040)H			



\*For details on the model items, refer to page 8.

Model	Axis configuration	Arm length (mm)	Motor capacity (W)	Work envelope	Positioning Repeatability (mm) (Note 1)	PTP operation Maximum operating speed (Note 2)	Standard cycle time (sec) (Note 3)	Load capacity (kg) (Note 4)		Axis 3 (vertical axis) push force (N) (Note 5)		Axis 4 allowable load		
								Rated	Maximum	Maximum limit	Minimum limit	Allowable inertial moment (kg·m <sup>2</sup> ) (Note 6)	Allowable torque (N·m)	
IX-HNN8020H-□-T2 [IX-HNN8040H-□]-T2 IX-INN8020H-□-T2 [IX-INN8040H-□]-T2	Axis 1	Arm 1	450	750	±125°	7586mm/s (Composite speed)	0.43	5	20	304	146.0	0.1	11.7	
	Axis 2	Arm 2	350	400	±145°									
	Axis 3	Vertical axis	-	400	200mm [400mm]	±0.10								1614mm/s
	Axis 4	Rotating axis	-	100	±360°	±0.005								1266°/s

\*In the model number above, specify the cable length in □.

\*SCARA robots cannot operate continuously at 100% speed and acceleration. For details on the operating conditions, refer to Reference Acceleration/Deceleration Settings on page 46.

**Common Specifications**

Encoder type	Absolute
User wiring	25-conductor AWG26 D-sub/25-pin connector with shield (socket)
User tubing	Air tube (O.D. ∅6, I.D. ∅4) x 2 (Normal working pressure 0.8 MPa) Air tube (O.D. ∅4, I.D. ∅2.5) x 2 (Normal working pressure 0.8 MPa)
Alarm indicator (Note 7)	Small red LED indicator x 1 (24 V DC must be supplied.)
Brake-release switch (Note 8)	Allows remote release of Z-axis (24 VDC required)

Ambient temperature/humidity	Temperature: 0–40 °C, humidity: 20–85%RH or less (no condensation)
Unit weight	58Kg
Applicable controller	T2: XSEL-PX/QX
Cable length (Note 9)	5L: 5 m (standard), 10L: 10 m (optional)

**Dimensions**

\*For the inverse type, the following illustrations should be turned upside down. (See page 2.)

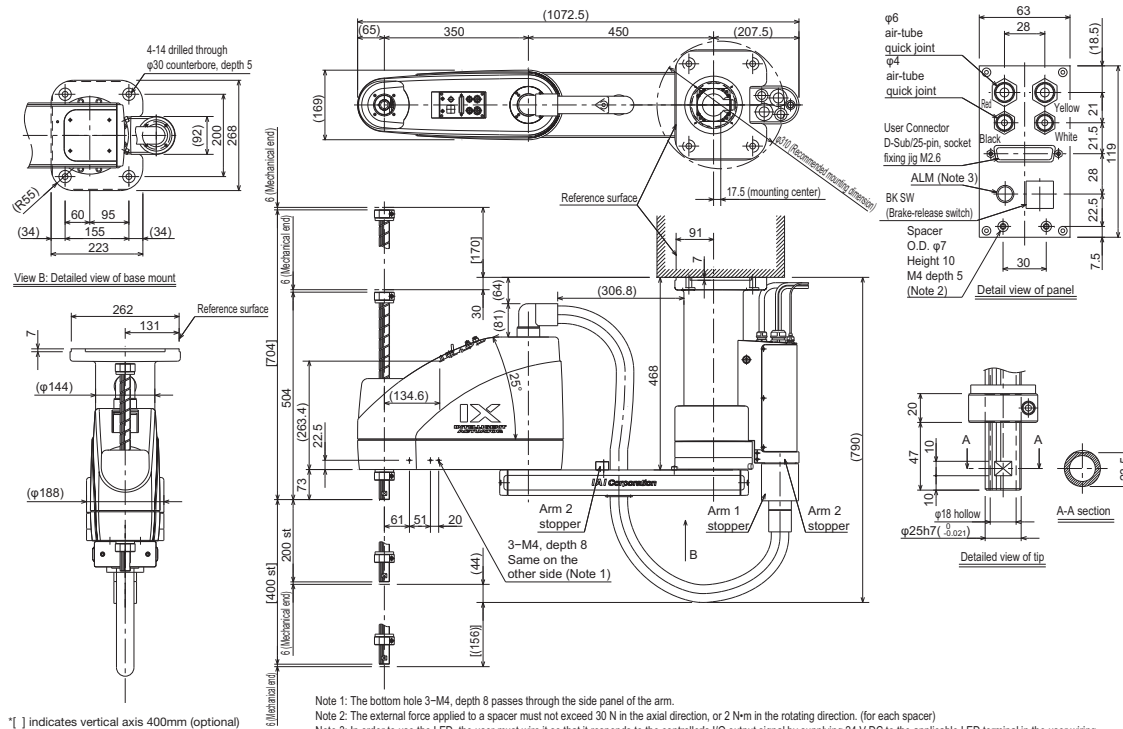

\*□ indicates vertical axis 400mm (optional) specifications.

**Applicable Controller Specifications**

Applicable Controller	Features	Maximum I/O points (inputs/outputs)	Power-supply voltage	Reference page
XSEL-PX	Maximum 5 axes, 2400 W supported	192/192 points	Three-phase 200 V AC	p. 37
XSEL-QX	Safety Category 4 supported			



For explanations of (Note 1) through (Note 9), refer to page 6.

# IX-NNC2515H

Small SCARA robot, Cleanroom type  
Arm length 250mm, Vertical axis 150mm



Model items **IX** — **NNC2515H** —  — **T2**

Series	Type	Cable length	Applicable controller
Cleanroom type		5L : 5 m (standard) 10L: 10 m	T2: XSEL-PX/QX
Arm length 250mm			
Vertical axis 150mm			

\*For details on the model items, refer to page 8.

### Model/Specifications

Model	Axis configuration		Arm length (mm)	Motor capacity (W)	Work envelope	Positioning Repeatability (mm) (Note 1)	PTP operation Maximum operating speed (Note 2)	Standard cycle time (sec) (Note 3)	Load capacity (kg) (Note 4)		Axis 3 (vertical axis) push force (N) (Note 5)		Axis 4 allowable load	
	Axis 1	Axis 2							Rated	Maximum	Maximum limit	Minimum limit	Allowable inertial moment (kg·m <sup>2</sup> ) (Note 6)	Allowable torque (N·m)
IX-NNC2515H- <span style="border: 1px solid black; display: inline-block; width: 15px; height: 15px;"></span> -T2	Arm 1	Arm 2	125	200	±120°	±0.010 (XY)	3191mm/s (Composite speed)	0.44	1	3	111.0	58.0	0.015	1.9
	Axis 2	Arm 2	125	100	±120°									
	Axis 3	Vertical axis	-	100	150mm	±0.010	1316mm/s							
	Axis 4	Rotating axis	-	50	±360°	±0.005	1600°/s							

\*In the model number above, specify the cable length in .

\*SCARA robots cannot operate continuously at 100% speed and acceleration. For details on the operating conditions, refer to Reference Acceleration/Deceleration Settings on page 45.

### Common Specifications

Encoder type	Absolute	Vacuum joint	Applicable tube O.D. φ12
User wiring	15-conductor AWG26 D-sub/15-pin connector with shield (socket)	Suction rate (Note 10)	60 Nl/min
User tubing	Air tube (O.D. φ4, I.D. φ2.5) x 3 (Normal working pressure 0.8 MPa)	Cleanliness class	Conforming to class 10 (0.1 μm)
Alarm indicator (Note 7)	Small red LED indicator x 1 (24 V DC must be supplied.)	Ambient temperature/humidity	Temperature: 0-40 °C, humidity: 20-85%RH or less (no condensation)
Brake-release switch (Note 8)	Allows remote release of Z-axis (24 VDC required)	Unit weight	19Kg
		Cable length (Note 9)	5L: 5 m (standard), 10L: 10 m (optional)

### Dimensions

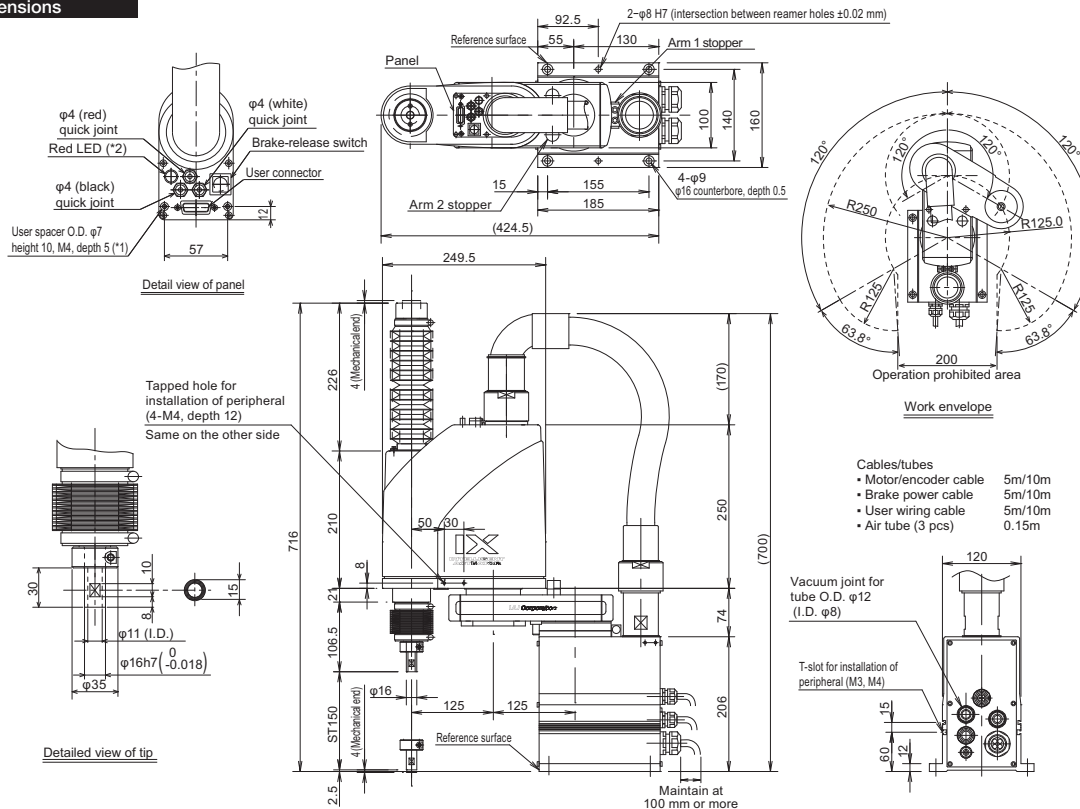

\*1: The external force applied to a spacer must not exceed 30 N in the axial direction, or 2 N·m in the rotating direction. (for each spacer)

\*2: In order to use the LED, the user must wire it so that it responds to the controller's I/O output signal by supplying 24 V DC to the applicable LED terminal in the user wiring.

### Applicable Controller Specifications

Applicable Controller	Features	Maximum I/O points (inputs/outputs)	Power-supply voltage	Reference page
XSEL-PX	Maximum 6 axes, 2400 W supported	192/192 points	Three-phase 200 V AC	p. 37
XSEL-QX	Safety Category 4 supported			



For explanations of (Note 1) through (Note 9), refer to page 6. (Note 10) In order to use the cleanroom type in an environment with cleanliness class 10, the air inside the robot must be vacuumed from the air suction outlet located at the side (or back) of the robot base. The suction rate listed in the above table is a general estimate. Increase the suction rate according to the actual operating conditions.

# IX-NNC3515H

Small SCARA robot, Cleanroom type  
Arm length 350mm, Vertical axis 150mm



Model items	<b>IX — NNC3515H</b>		<b>T2</b>
Series	Type	Cable length	Applicable controller
Cleanroom type		5L : 5 m (standard)	T2: XSEL-PX/QX
Arm length 350mm,		10L: 10 m	
Vertical axis 150mm			

\*For details on the model items, refer to page 8.

## Model/Specifications

Model	Axis configuration		Arm length (mm)	Motor capacity (W)	Work envelope	Positioning Repeatability (mm) (Note 1)	PTP operation Maximum operating speed (Note 2)	Standard cycle time (sec) (Note 3)	Load capacity (kg) (Note 4)		Axis 3 (vertical axis) push force (N) (Note 5)		Axis 4 allowable load	
	Axis 1	Axis 2							Rated	Maximum	Maximum limit	Minimum limit	Allowable inertial moment (kg·m <sup>2</sup> ) (Note 6)	Allowable torque (N·m)
IX-NNC3515H--T2	Axis 1	Arm 1	225	200	±120°	±0.010 (XY)	4042mm/s (Composite speed)	0.46	1	3	111.0	58.0	0.015	1.9
	Axis 2	Arm 2	125	100	±135°		1316mm/s							
	Axis 3	Vertical axis	-	100	150mm	±0.010	1600*/s							
	Axis 4	Rotating axis	-	50	±360°	±0.005								

\*In the model number above, specify the cable length in .

\*SCARA robots cannot operate continuously at 100% speed and acceleration. For details on the operating conditions, refer to Reference Acceleration/Deceleration Settings on page 45.

## Common Specifications

Encoder type	Absolute	Vacuum joint	Applicable tube O.D. $\phi 12$
User wiring	15-conductor AWG26 D-sub/15-pin connector with shield (socket)	Suction rate (Note 10)	60 N <sub>l</sub> /min
User tubing	Air tube (O.D. $\phi 4$ , I.D. $\phi 2.5$ ) x 3 (Normal working pressure 0.8 MPa)	Cleanliness class	Conforming to class 10 (0.1 $\mu$ m)
Alarm indicator (Note 7)	Small red LED indicator x 1 (24 V DC must be supplied.)	Ambient temperature/humidity	Temperature: 0-40 °C, humidity: 20-85%RH or less (no condensation)
Brake-release switch (Note 8)	Allows remote release of Z-axis (24 VDC required)	Unit weight	20Kg
		Cable length (Note 9)	5L: 5 m (standard), 10L: 10 m (optional)

## Dimensions

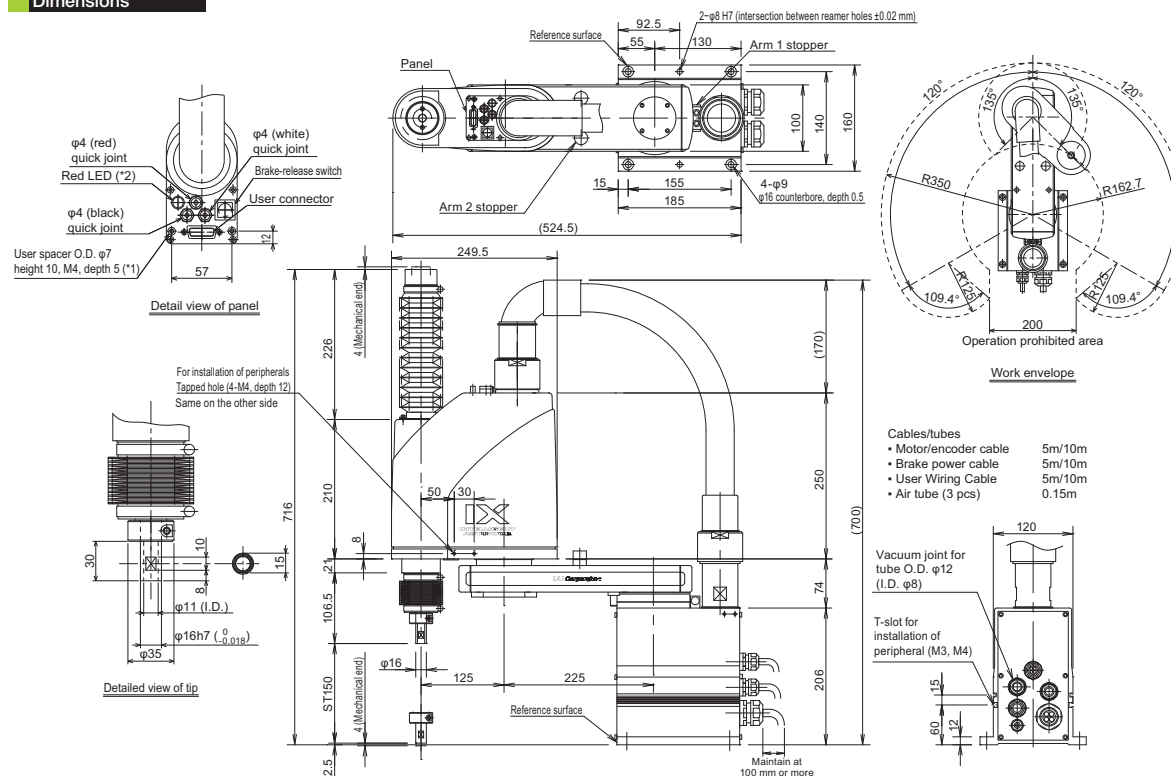

\*1: The external force applied to a spacer must not exceed 30 N in the axial direction, or 2 N·m in the rotating direction. (for each spacer)

\*2: In order to use the LED, the user must wire it so that it responds to the controller's I/O output signal by supplying 24 V DC to the applicable LED terminal in the user wiring.

## Applicable Controller Specifications

Applicable Controller	Features	Maximum I/O points (inputs/outputs)	Power-supply voltage	Reference page
XSEL-PX	Maximum 6 axes, 2400 W supported	192/192 points	Three-phase 200 V AC	p. 37
XSEL-QX	Safety Category 4 supported			

**Caution**

For explanations of (Note 1) through (Note 9), refer to page 6. (Note 10) In order to use the cleanroom type in an environment with cleanliness class 10, the air inside the robot must be vacuumed from the air suction outlet located at the side (or back) of the robot base. The suction rate listed in the above table is a general estimate. Increase the suction rate according to the actual operating conditions.

# IX-NNC50□□H

Medium SCARA robot, Cleanroom type  
Arm length 500mm  
Vertical axis 200mm (300mm)



## Model items IX — NNC50□□H — □ — T2

Series	Type	Cable length	Applicable controller
NNC5020H: Arm length 500mm, Vertical axis 200mm	□□H	5L : 5 m (standard)	T2: XSEL-PX/QX
NNC5030H: Arm length 500mm, Vertical axis 300mm		10L: 10 m	

\*For details on the model items, refer to page 8.

### Model/Specifications

Model	Axis configuration		Arm length (mm)	Motor capacity (W)	Work envelope	Positioning Repeatability (mm) (Note 1)	PTP operation Maximum operating speed (Note 2)	Standard cycle time (sec) (Note 3)	Load capacity (kg) (Note 4)		Axis 3 (vertical axis) push force (N) (Note 5)		Axis 4 allowable load	
	Axis 1	Axis 2							Rated	Maximum	Maximum limit	Minimum limit	Allowable inertial moment (kg·m <sup>2</sup> ) (Note 6)	Allowable torque (N·m)
IX-NNC5020H-□□-T2 [IX-NNC5030H-□□-T2]	Axis 1	Arm 1	250	400	±120°	±0.010 (XY)	6381mm/s (Composite speed)	0.41	2	10	181.0	93	0.06	3.7
	Axis 2	Arm 2	250	200	±145°									
	Axis 3	Vertical axis	-	200	200mm [300mm]	±0.010	1473mm/s							
	Axis 4	Rotating axis	-	100	±360°	±0.005	1857°/s							

\*In the model number above, specify the cable length in □.

□ indicates vertical axis 300mm specifications. All other specifications are common to both the vertical axis 200mm and 300mm.

\*SCARA robots cannot operate continuously at 100% speed and acceleration. For details on the operating conditions, refer to Reference Acceleration/Deceleration Settings on page 45.

### Common Specifications

Encoder type	Absolute	Vacuum joint	Quick joint, Applicable tube O.D. φ12
User wiring	25-conductor AWG26 D-sub/25-pin connector with shield (socket)	Suction rate (Note 10)	60 Nℓ/min
User tubing	Air tube (O.D. φ6, I.D. φ4) x 2 (Normal working pressure 0.8 MPa)	Cleanliness class	Conforming to class 10 (0.1 μm)
	Air tube (O.D. φ4, I.D. φ2.5) x 2 (Normal working pressure 0.8 MPa)	Ambient temperature/humidity	Temperature: 0-40 °C, humidity: 20-85%RH or less (no condensation)
Alarm indicator (Note 7)	Small red LED indicator x 1 (24 V DC must be supplied.)	Unit weight	31.5Kg
Brake-release switch (Note 8)	Allows remote release of Z-axis (24 VDC required)	Cable length (Note 9)	5L: 5 m (standard), 10L: 10 m (optional)

### Dimensions

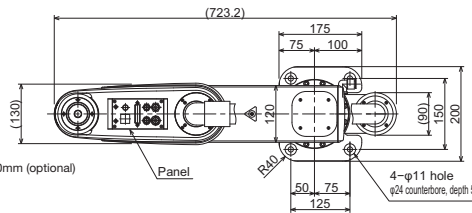

□ indicates vertical axis 300mm (optional) specifications.

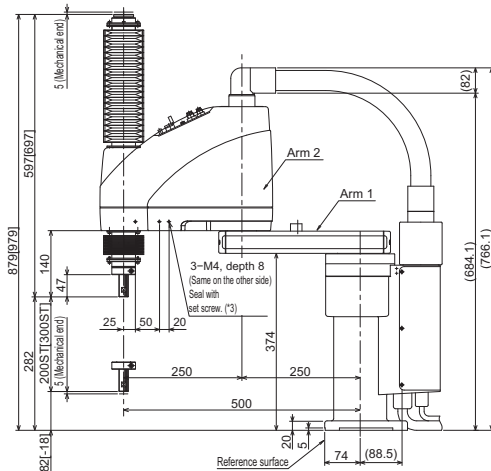

The values within □ indicate the specifications for axis 3 (vertical axis) 300 mm.

- \*1: The external force applied to a spacer must not exceed 30 N in the axial direction, or 2 N·m in the rotating direction. (for each spacer)
- \*2: In order to use the LED, the user must wire it so that it responds to the controller's I/O output signal by supplying 24 V DC to the applicable LED terminal in the user wiring.
- \*3: The prepared hole 3-M4, depth 8 passes through the side panel of the arm. If the mounting screw is long, make sure it does not contact internal components. In addition, be sure to seal screws with tape.

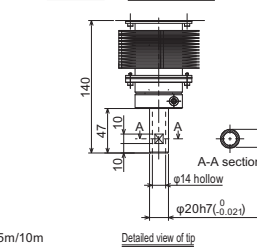
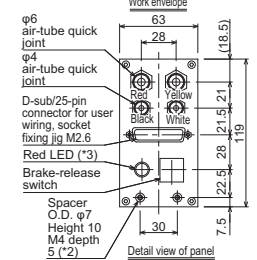
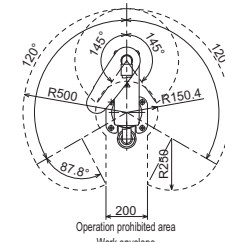
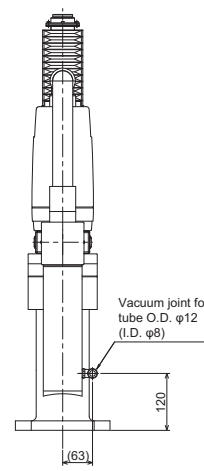

- Cables/tubes
- Motor/encoder cable 5m/10m
- Brake power cable 5m/10m
- User Wiring Cable 5m/10m
- Air tube (4 pcs) 0.15m

### Applicable Controller Specifications

Applicable Controller	Features	Maximum I/O points (inputs/outputs)	Power-supply voltage	Reference page
XSEL-PX	Maximum 6 axes, 2400 W supported	192/192 points	Three-phase 200 V AC	p. 37
XSEL-QX	Safety Category 4 supported			



For explanations of (Note 1) through (Note 9), refer to page 6. (Note 10) In order to use the cleanroom type in an environment with cleanliness class 10, the air inside the robot must be vacuumed from the air suction outlet located at the side (or back) of the robot base. The suction rate listed in the above table is a general estimate. Increase the suction rate according to the actual operating conditions.

**31** IX-NNC50□□H



# IX-NNC60□□H Medium SCARA robot, Cleanroom type Arm length 600mm, Vertical axis 200mm (300mm)



■ Model items IX — NNC60□□H — □ — T2			
Series	Type	Cable length	Applicable controller
NNC6020H: Arm length 600mm, Vertical axis 200mm		5L : 5 m (standard)	T2: XSEL-PX/QX
NNC6030H: Arm length 600mm, Vertical axis 300mm		10L: 10 m	

\*For details on the model items, refer to page 8.

## Model/Specifications

Model	Axis configuration		Arm length (mm)	Motor capacity (W)	Work envelope	Positioning Repeatability (mm) (Note 1)	PTP operation Maximum operating speed (Note 2)	Standard cycle time (sec) (Note 3)	Load capacity (kg) (Note 4)		Axis 3 (vertical axis) push force (N) (Note 5)		Axis 4 allowable load	
	Axis 1	Axis 2							Rated	Maximum	Maximum limit	Minimum limit	Allowable inertial moment (kg·m <sup>2</sup> ) (Note 6)	Allowable torque (N·m)
IX-NNC6020H-□-T2 [IX-NNC6030H-□-T2]	Axis 1	Arm 1	350	400	±120°	±0.010 (XY)	7232mm/s (Composite speed)	0.45	2	10	181.0	93	0.06	3.7
	Axis 2	Arm 2	250	200	±145°									
	Axis 3	Vertical axis	-	200	200mm (300mm)	±0.010	1473mm/s							
	Axis 4	Rotating axis	-	100	±360°	±0.005	1857°/s							

\*In the model number above, specify the cable length in [ ].

[ ] indicates vertical axis 300mm specifications. All other specifications are common to both the vertical axis 200mm and 300mm.

\*SCARA robots cannot operate continuously at 100% speed and acceleration. For details on the operating conditions, refer to Reference Acceleration/Deceleration Settings on page 45.

## Common Specifications

Encoder type	Absolute	Vacuum joint	Quick joint, Applicable tube O.D. φ12
User wiring	25-conductor AWG26 D-sub/25-pin connector with shield (socket)	Suction rate (Note 10)	Nl/min
User tubing	Air tube (O.D. φ6, I.D. φ4) x 2 (Normal working pressure 0.8 MPa) Air tube (O.D. φ4, I.D. φ2.5) x 2 (Normal working pressure 0.8 MPa)	Cleanliness class	Conforming to class 10 (0.1 μm)
Alarm indicator (Note 7)	Small red LED indicator x 1 (24 V DC must be supplied.)	Ambient temperature/humidity	Temperature: 0-40 °C, humidity: 20-85%RH or less (no condensation)
Brake-release switch (Note 8)	Allows remote release of Z-axis (24 VDC required)	Unit weight	32.5Kg
		Cable length (Note 9)	5L: 5 m (standard), 10L: 10 m (optional)

## Dimensions

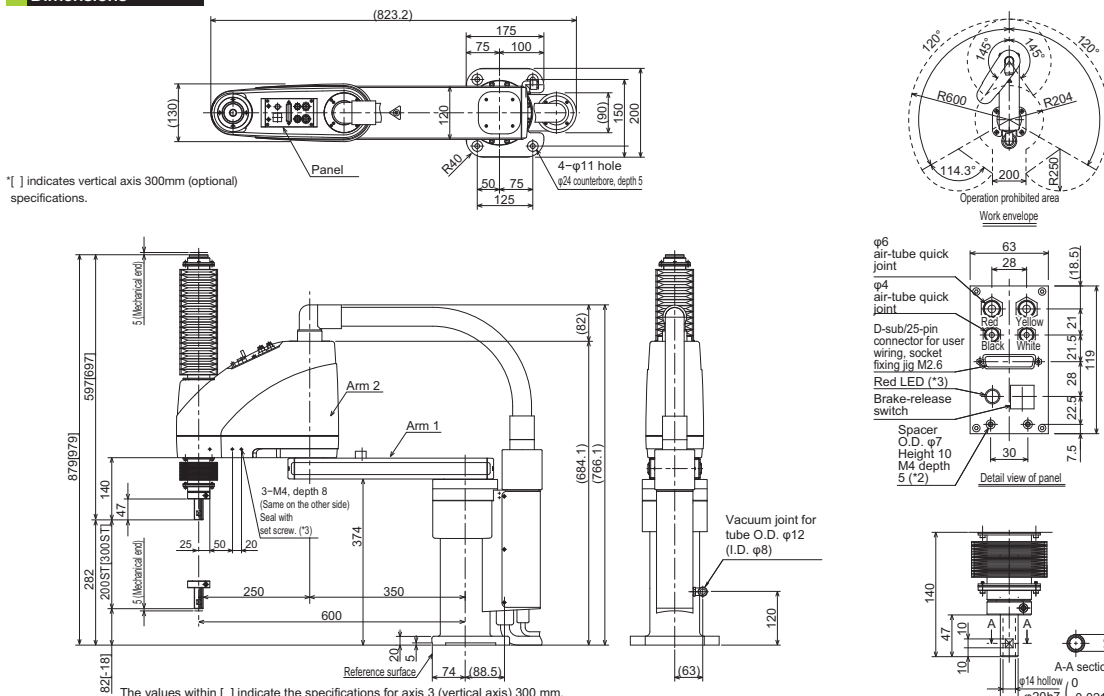

[ ] indicates vertical axis 300mm (optional) specifications.

The values within [ ] indicate the specifications for axis 3 (vertical axis) 300 mm.

- \*1: The external force applied to a spacer must not exceed 30 N in the axial direction, or 2 N·m in the rotating direction. (for each spacer)
- \*2: In order to use the LED, the user must wire it so that it responds to the controller's I/O output signal by supplying 24 V DC to the applicable LED terminal in the user wiring.
- \*3: The prepared hole 3-M4, depth 8 passes through the side panel of the arm. If the mounting screw is long, make sure it does not contact internal components. In addition, be sure to seal screws with tape.

- Cables/tubes
- Motor/encoder cable 5m/10m
- Brake power cable 5m/10m
- User Wiring Cable 5m/10m
- Air tube (4 pcs) 0.15m

## Applicable Controller Specifications

Applicable Controller	Features	Maximum I/O points (inputs/outputs)	Power-supply voltage	Reference page
XSEL-PX	Maximum 6 axes, 2400 W supported	192/192 points	Three-phase 200 V AC	p. 37
XSEL-QX	Safety Category 4 supported			



For explanations of (Note 1) through (Note 9), refer to page 6. (Note 10) In order to use the cleanroom type in an environment with cleanliness class 10, the air inside the robot must be vacuumed from the air suction outlet located at the side (or back) of the robot base. The suction rate listed in the above table is a general estimate. Increase the suction rate according to the actual operating conditions.

# IX-NNC70□□H Large SCARA robot, Cleanroom type

Arm length 700mm, Vertical axis 200mm (400mm)



## Model items IX — NNC70□□H — □ — T2

Series	Type	Cable length	Applicable controller
NNC7020H: Arm length 700mm, Vertical axis 200mm		5L : 5 m (standard) 10L: 10 m	T2: XSEL-PX/QX
NNC7040H: Arm length 700mm, Vertical axis 400mm			

\*For details on the model items, refer to page 8.

### Model/Specifications

Model	Axis configuration	Arm length (mm)	Motor capacity (W)	Work envelope	Positioning Repeatability (mm) (Note 1)	PTP operation Maximum operating speed (Note 2)	Standard cycle time (sec) (Note 3)	Load capacity (kg) (Note 4)		Axis 3 (vertical axis) push force (N) (Note 5)		Axis 4 allowable load	
								Rated	Maximum	Maximum limit	Minimum limit	Allowable inertial moment (kg·m <sup>2</sup> ) (Note 6)	Allowable torque (N·m)
IX-NNC7020H-□-T2 [IX-NNC7040H-□-T2]	Axes 1 Arm 1	350	750	±125°	±0.015 (XY)	7010mm/s (Composite speed)	0.45	5	20	304	146.0	0.1	11.7
	Axes 2 Arm 2	350	400	±145°									
	Axes 3 Vertical axis	-	400	200mm [400mm]	±0.010	1614mm/s							
	Axes 4 Rotating axis	-	200	±360°	±0.005	1266°/s							

\*In the model number above, specify the cable length in □.

\*SCARA robots cannot operate continuously at 100% speed and acceleration. For details on the operating conditions, refer to Reference Acceleration/Deceleration Settings on page 46.

### Common Specifications

Encoder type	Absolute
User wiring	25-conductor AW26 D-sub/25-pin connector with shield (socket)
User tubing	Air tube (O.D. ø6, I.D. ø4) x 2 (Normal working pressure 0.8 MPa)
	Air tube (O.D. ø4, I.D. ø2.5) x 2 (Normal working pressure 0.8 MPa)
Alarm indicator (Note 7)	Small red LED indicator x 1 (24 V DC must be supplied.)
Brake-release switch (Note 8)	Allows remote release of Z-axis (24 VDC required)

Vacuum joint	Quick joint, Applicable tube O.D. ø12
Suction rate (Note 10)	80 Nℓ/min
Cleanliness class	Conforming to class 10 (0.1 μm)
Ambient temperature/humidity	Temperature: 0-40 °C, humidity: 20-85%RH or less (no condensation)
Unit weight	60Kg
Cable length (Note 9)	5L: 5 m (standard), 10L: 10 m (optional)

### Dimensions

The CAD drawings can be downloaded from our Web site.



[ ] indicates vertical axis 400mm (optional) specifications.

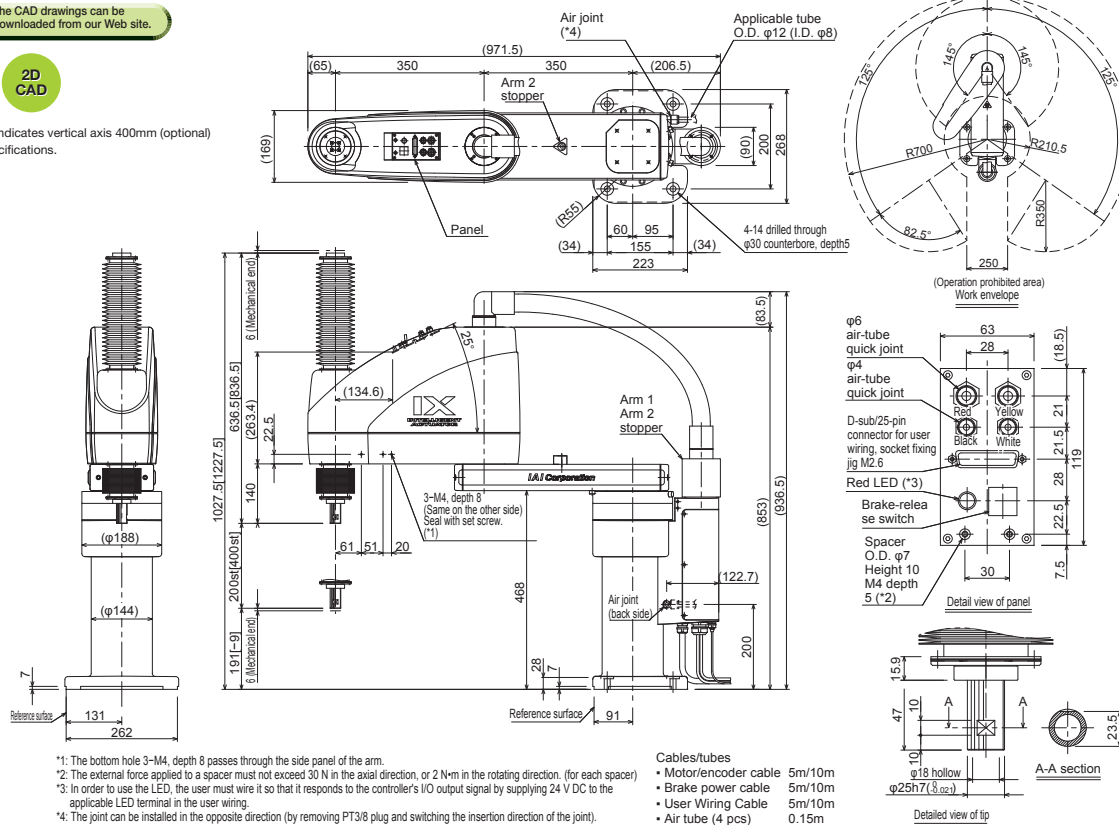

\*1: The bottom hole 3-M4, depth 8 passes through the side panel of the arm.  
 \*2: The external force applied to a spacer must not exceed 30 N in the axial direction, or 2 N·m in the rotating direction. (for each spacer)  
 \*3: In order to use the LED, the user must wire it so that it responds to the controller's I/O output signal by supplying 24 V DC to the applicable LED terminal in the user wiring.  
 \*4: The joint can be installed in the opposite direction (by removing PT3/8 plug and switching the insertion direction of the joint).

- Cables/tubes
- Motor/encoder cable 5m/10m
  - Brake power cable 5m/10m
  - User Wiring Cable 5m/10m
  - Air tube (4 pcs) 0.15m

### Applicable Controller Specifications

Applicable Controller	Features	Maximum I/O points (inputs/outputs)	Power-supply voltage	Reference page
XSEL-PX	Controller dedicated to SCARA	192/192 points	Three-phase 200 V AC	p. 37
XSEL-QX	Safety Category 4 supported			



For explanations of (Note 1) through (Note 9), refer to page 6. (Note 10) In order to use the cleanroom type in an environment with cleanliness class 10, the air inside the robot must be vacuumed from the air suction outlet located at the side (or back) of the robot base. The suction rate listed in the above table is a general estimate. Increase the suction rate according to the actual operating conditions.

# 33 IX-NNC70□□H

# IX-NNC80□□H

Large SCARA robot, Cleanroom type  
Arm length 800mm, Vertical axis 200mm (400mm)

IX SCARA

IX SCARA



## Model items IX — NNC80□□H — □ — T2

Series	Type	Cable length	Applicable controller
NNC8020H: Arm length 800mm, Vertical axis 200mm		5L : 5 m (standard)	T2: XSEL-PX/QX
NNC8040H: Arm length 800mm, Vertical axis 400mm		10L: 10 m	

\*For details on the model items, refer to page 8.

### Model/Specifications

Model	Axis configuration	Arm length (mm)	Motor capacity (W)	Work envelope	Positioning Repeatability (mm) (Note 1)	PTP operation Maximum operating speed (Note 2)	Standard cycle time (sec) (Note 3)	Load capacity (kg) (Note 4)		Axis 3 (vertical axis) push force (N) (Note 5)		Axis 4 allowable load	
								Rated	Maximum	Maximum limit	Minimum limit	Allowable inertial moment (kg·m <sup>2</sup> ) (Note 6)	Allowable torque (N·m)
IX-NNC8020H-□-T2 [IX-NNC8040H-□-T2]	Axis 1 Arm 1	450	750	±125°	±0.015 (XY)	7586mm/s (Composite speed)	0.46	5	20	304	146.0	0.1	11.7
	Axis 2 Arm 2	350	400	±145°									
	Axis 3 Vertical axis	-	400	200mm [400mm]	±0.010	1614mm/s							
	Axis 4 Rotating axis	-	200	±360°	±0.005	1266°/s							

\*In the model number above, specify the cable length in □.

\*SCARA robots cannot operate continuously at 100% speed and acceleration. For details on the operating conditions, refer to Reference Acceleration/Deceleration Settings on page 46.

### Common Specifications

Encoder type	Absolute
User wiring	25-conductor AW26 D-sub/25-pin connector with shield (socket)
User tubing	Air tube (O.D. $\varnothing$ 6, I.D. $\varnothing$ 4) x 2 (Normal working pressure 0.8 MPa)
	Air tube (O.D. $\varnothing$ 4, I.D. $\varnothing$ 2.5) x 2 (Normal working pressure 0.8 MPa)
Alarm indicator (Note 7)	Small red LED indicator x 1 (24 V DC must be supplied.)
Brake-release switch (Note 8)	Allows remote release of Z-axis (24 VDC required)

Vacuum joint	Quick joint, Applicable tube O.D. $\varnothing$ 12
Suction rate (Note 10)	80 N $\ell$ /min
Cleanliness class	Conforming to class 10 (0.1 $\mu$ m)
Ambient temperature/humidity	Temperature: 0–40 °C, humidity: 20–85%RH or less (no condensation)
Unit weight	62Kg
Cable length (Note 9)	5L: 5 m (standard), 10L: 10 m (optional)

### Dimensions

[ ] indicates vertical axis 400mm (optional) specifications.

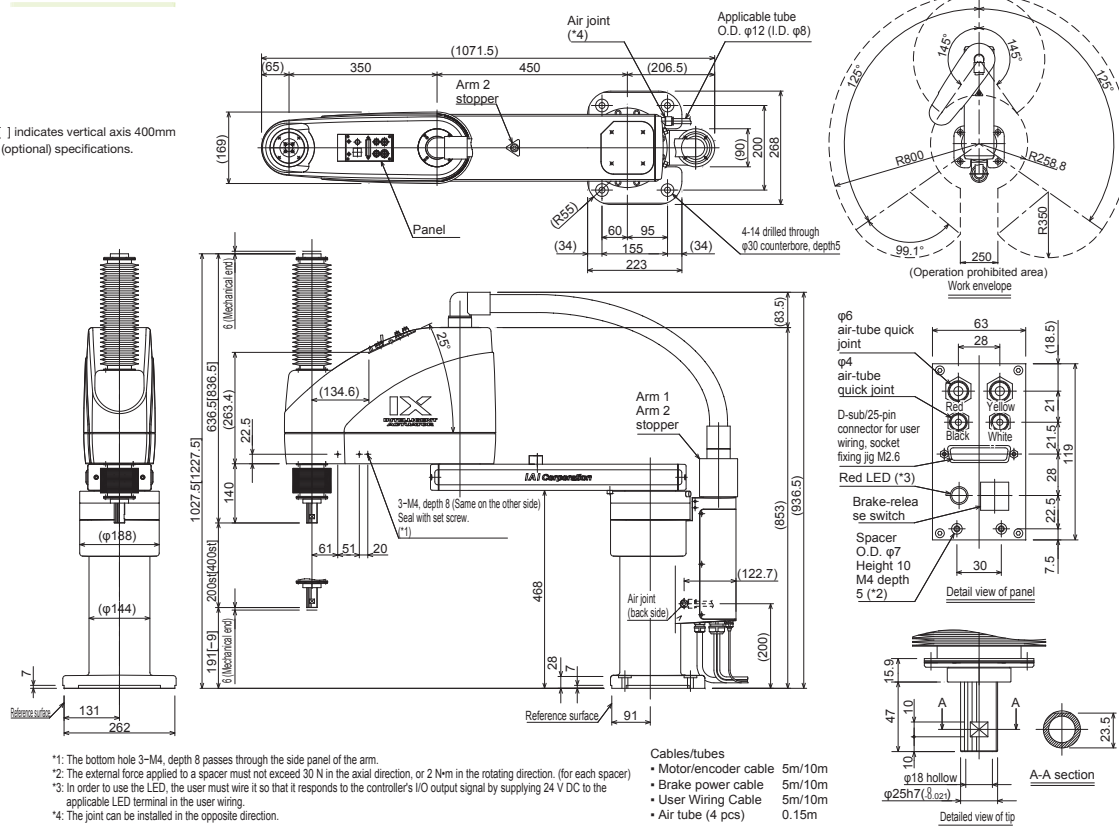

\*1: The bottom hole 3-M4, depth 8 passes through the side panel of the arm.

\*2: The external force applied to a spacer must not exceed 30 N in the axial direction, or 2 N·m in the rotating direction. (for each spacer)

\*3: In order to use the LED, the user must wire it so that it responds to the controller's I/O output signal by supplying 24 V DC to the applicable LED terminal in the user wiring.

\*4: The joint can be installed in the opposite direction.

### Applicable Controller Specifications

Applicable Controller	Features	Maximum I/O points (inputs/outputs)	Power-supply voltage	Reference page
XSEL-PX	Controller dedicated to SCARA	192/192 points	Three-phase 200 V AC	p. 37
XSEL-QX	Safety Category 4 supported			



For explanations of (Note 1) through (Note 9), refer to page 6. (Note 10) In order to use the cleanroom type in an environment with cleanliness class 10, the air inside the robot must be vacuumed from the air suction outlet located at the side (or back) of the robot base. The suction rate listed in the above table is a general estimate. Increase the suction rate according to the actual operating conditions.

# SCARA Robot Series System Configuration Drawing

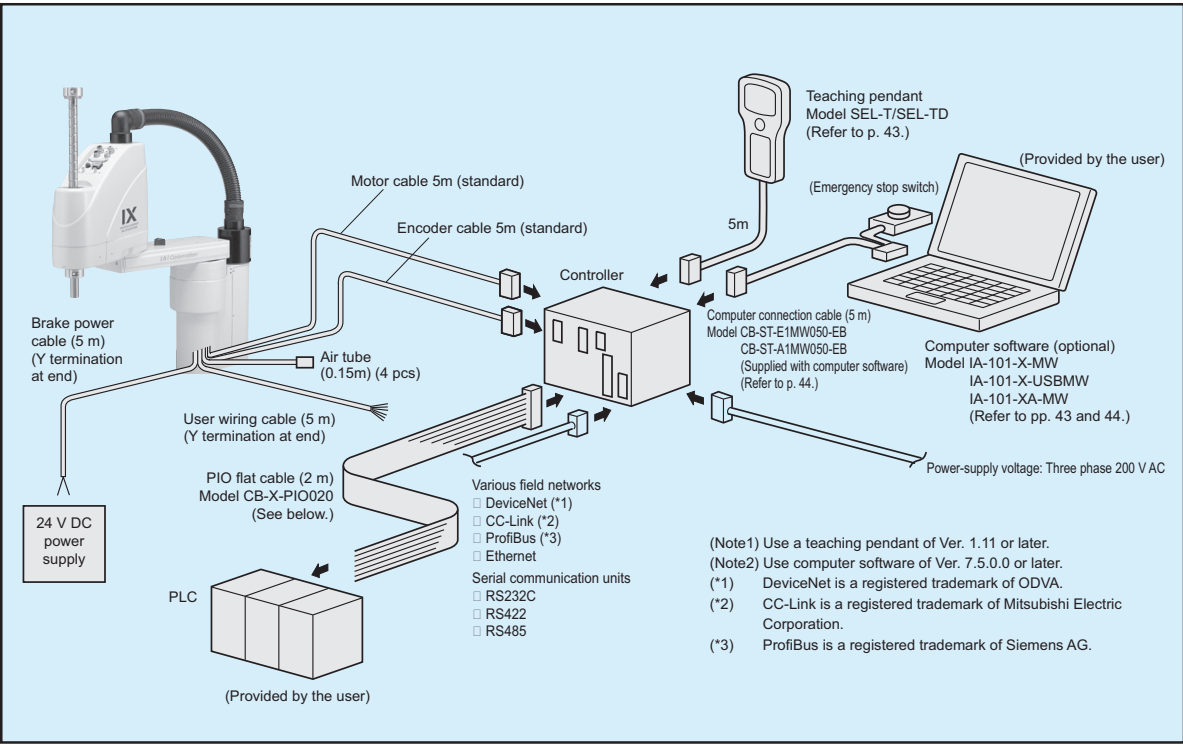

## Robot Accessories

- Caution labels
- Positioning seals
- Eyebolts
- Service connectors

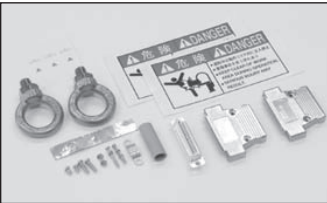

## Controller Accessories

- PIO flat cable \*□□□ represents the cable length (L); supports up to 10 m. Example: 080 = 8 m

Model **CB-X-PIO**□□□

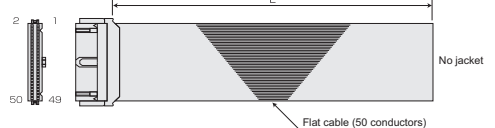

Number	Color	Wire	Number	Color	Wire	Number	Color	Wire
1	Brown 1	Flat cable, pressure-welded	18	Gray 2	Flat cable, pressure-welded	35	Green 4	Flat cable, pressure-welded
2	Red 1		19	White 2		36	Blue 4	
3	Orange 1		20	Black 2		37	Purple 4	
4	Yellow 1		21	Brown 3		38	Gray 4	
5	Green 1		22	Red 3		39	White 4	
6	Blue 1		23	Orange 3		40	Black 4	
7	Purple 1		24	Yellow 3		41	Brown 5	
8	Gray 1		25	Green 3		42	Red 5	
9	White 1		26	Blue 3		43	Orange 5	
10	Black 1		27	Purple 3		44	Yellow 5	
11	Brown 2		28	Gray 3		45	Green 5	
12	Red 2		29	White 3		46	Blue 5	
13	Orange 2		30	Black 3		47	Purple 5	
14	Yellow 2		31	Brown 4		48	Gray 5	
15	Green 2		32	Red 4		49	White 5	
16	Blue 2		33	Orange 4		50	Black 5	
17	Purple 2		34	Yellow 4				

## Robot Options

Name	Model	Description	Reference page
Absolute data storage battery	AB-3	Battery for storing the encoder's absolute data	p. 36
Absolute reset adjustment jig	JG-1~4	Jig needed to perform an absolute reset	
Flange	IX-FL-1~3	Flange for mounting objects on the tip of the Z-axis	

## Controller Options

Name	Model	Description	Reference page
Teaching pendant (dustproof)	SEL-T	Compatible with protective structure IP54	p. 43
Teaching pendant (ANSI)	SEL-TD	Complies with CE/ANSI protocols	
Computer software (DOS/V)	IA-101-X-MW	Allows for input and editing of position data, programs, parameters, etc. as well as manual operations.	p. 44
Computer software (USB)	IA-101-X-USBMW	With a USB-compatible computer connection cable	
Computer software (compatible with Safety Category 4)	IA-101-XA-MW	With a communication cable providing a redundant emergency stop circuit	

# SCARA Robot Series Robot Options

## Absolute reset adjustment jig

The adjustment jig is used if it is necessary to perform an absolute reset when the encoder's absolute data is lost.

Model	Note
<b>JG-1</b>	For arm length 500/600
<b>JG-2</b>	For arm length 250/350
<b>JG-3</b>	For arm length 700/800
<b>JG-4</b>	For high-speed type, arm length 500/600



JG-1

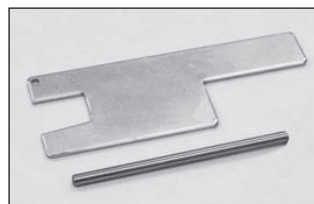

JG-2

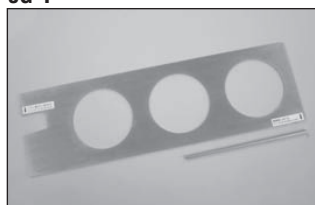

JG-3



JG-4

## Flange

Use a flange when mounting an object on the tip of the Z-axis arm.

Model	Note
<b>IX-FL-1</b>	For arm length 500/600
<b>IX-FL-2</b>	For arm length 250/350 For high-speed type, arm length 500/600
<b>IX-FL-3</b>	For arm length 700/800

### Note

Use IX-FL-2 with arm length 500/600 of the high-speed type.

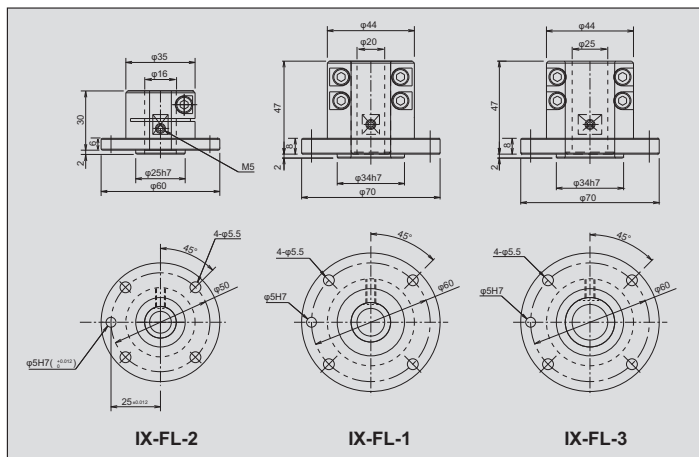

IX-FL-2

IX-FL-1

IX-FL-3

# SCARA Robot Series Maintenance Parts

## Absolute data backup battery

This battery is used to store the encoder's absolute data. (Install the battery behind the rear cover of the SCARA robot.)

Model	Note
<b>AB-3</b>	For arm length 250-800

\*Four batteries are required for each robot (all SCARA robot models). Since the AB-3 package contains a single battery, be sure to specify the required number when ordering.





AB-3



**Model List**

These multiple-axes program controllers can be used to control SCARA robots. They can control a maximum of 6 axes simultaneously.

Type name	PX	QX
Name	Large-capacity type	Large-capacity type (safety-category-compatible specifications)
External view		
Description	Capable of operating a SCARA robot and 2 single-axis robots	PX type compatible with the Safety Category
Maximum number of controlled axes	6 axes	
Number of programs	128 points	
Number of program steps	9,999 steps	
Number of positions	20,000 positions	
Total wattage for connectable axes	2400 W	
Power	Three-phase 200 V AC	
Safety category	B	Complies with Category 4
Safety rating	CE	CE, ANSI
ROBO Cylinder gateway function	Standard equipment	Standard equipment

Model

[XSEL-PX/QX type]

\*The specifications for axis 5 and axis 6 are entered for models PX5/QX5/PX6/QX6.  
 \*With arm length 700/800, the maximum number of connected axes is 5 (SCARA + single axis).  
 \*With the high-speed type, the maximum number of connected axes is 4 (SCARA only).

**XSEL** - [ ] - [ ] - ([ ] [ ] [ ]) - ([ ] [ ] [ ]) - [ ] - [ ] - [ ] - [ ] - [ ] - [ ]

Series      Type      IX Model      (Axis 5 details)      (Axis 6 details)      (Slot 1)      (Slot 2)      (Slot 3)      (Slot 4)      I/O Cable length      Power/Voltage

Motor Type      Encoder Type      Option      Motor Type      Encoder Type      Option      Network Slot      Standard I/O      Expansion I/O

PX4	Large-Capacity 4-Axis Type		B	Brake		I	Incremental			3	Three-Phase 200 V AC
PX5	Large-Capacity 5-Axis Type		C	Creep Sensor		A	Absolute				
PX6	Large-Capacity 6-Axis Type		L	Home Sensor/LS-Compatible							
QX4	Large-Capacity Global 4-Axis Type		M	Master axis specification							
QX5	Large-Capacity Global 5-Axis Type		S	Slave Axis Specification							
QX6	Large-Capacity Global 6-Axis Type										

None	Not Used	E	Not Used
DV	DeviceNet Connection Board	N1	Input 32/Output 16 (NPN)
CC	CC-Link Connection Board	N2	Input 16/Output 32 (NPN)
PR	Profibus Connection Board	N3	Input 48/Output 48 (NPN)
ET	Ethernet Connection Board	P1	Input 32/Output 16 (PNP)
		P2	Input 16/Output 32 (PNP)
		P3	Input 48/Output 48 (PNP)
		S	With Expansion I/O Base

NNN2515H~8040H	Standard Type
NSN5016H~6016H	High-Speed Type
NNC2515H~8040H	Clean Room Type
NNW2515H~8040H	Splash-proof Type
TNN3015H~3515H	Wall Mount type
UNN3015H~3515H	Wall Mount Inverse Type
HNN5020H~8040H	Ceiling Mount Type
INN5020H~8040H	Inverse type

20	20W Servo Motor	200	200W Servo Motor
30D	RCS2 30W Servo Motor	300	300W Servo Motor
30R	RS 30W Servo Motor	400	400W Servo Motor
60	60W Servo Motor	600	600W Servo Motor
100	100W Servo Motor	750	750W Servo Motor
150	150W Servo Motor		

20	20W Servo Motor	200	200W Servo Motor
30D	RCS2 30W Servo Motor	300	300W Servo Motor
30R	RS 30W Servo Motor	400	400W Servo Motor
60	60W Servo Motor	600	600W Servo Motor
100	100W Servo Motor	750	750W Servo Motor
150	150W Servo Motor		

\*If no expansion I/O is used, enter "E" (Not Used) for slot 2 to slot 4.  
 If an expansion I/O is to be used, enter the expansion I/O code (listed on the left side) at the slot position where it is to be installed.  
 If an expansion I/O is specified, the controller chassis must be specified as the one with the expansion I/O base.  
 If an expansion I/O will not initially be used, but will be installed later, be sure to order a chassis with an expansion I/O base, and enter "S" for slots 2 through 4.

Example: If an expansion I/O is installed into slot 2 and no other slots are to be used      XSEL-PX4-NNN1205-N1-N1EE-2-3  
 If only the expansion I/O base is to be installed and no expansion I/O are to be used      XSEL-PX4-NNN1205-N1-SSS-2-3

**Note**

Axis 5 and axis 6 of the XSEL-PX/QX type cannot operate LSA series or RCS2-RA7/SRA7 series actuators.

## System Configuration

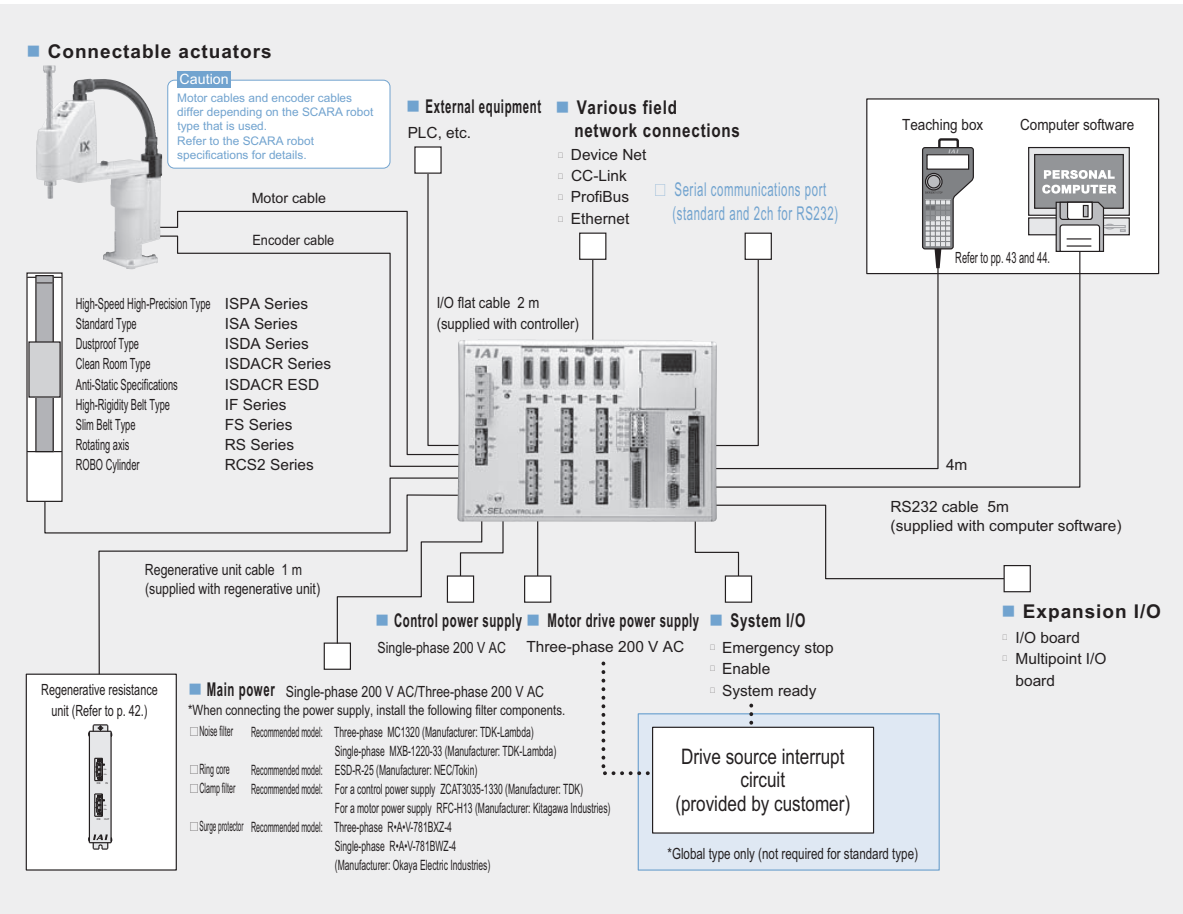

## Table of Specifications

Item	Description	
Controller type	PX	QX
Number of controlled axes	6 axes	
Maximum output of connected axes	2400 W	
Control power input	Single-phase 200/230 V AC, -15%+10%	
Motor power input	Three-phase 200/230 V AC, ±10%	
Power-supply capacity	Max. 3350 VA	
Safety circuit configuration	Redundancy not supported	Redundancy supported
Drive source cutoff method	Internal cutoff relay	External cutoff relay
Enable input	B contact input	B contact input (duplex)
Position detection method	Incremental/absolute	
Programming language	Super SEL language	
Number of programs	128 programs	
Number of program steps	9,999 steps (total)	
Number of positions	20,000 positions	
Multitasking	16 programs	
Standard inputs	32 points (total of dedicated inputs + general-purpose inputs)	
Standard outputs	16 points (total of dedicated outputs + general-purpose outputs)	
Expansion inputs/outputs	Total of 384 input/output points (*1)	
Serial communication	Standard equipment	
Operating temperature/humidity	0-40 °C, 10%-95% (no condensation)	
Unit weight	5.2-5.7 kg	4.5-5 kg

(\*1) When four multipoint I/O boards have been installed



## I/O Wiring Diagrams

### Input section External input specifications (NPN specifications)

Item	Specifications
Input power supply	24 V DC $\pm 10\%$
Input current	7 mA/circuit
On/Off voltage	On voltage...Min. 16.0 V DC, Off voltage...Max. 5.0 V DC
Insulation method	Photocoupler insulation
External devices	① No-voltage contact (with a minimum load of approx. 5 V DC/1 mA) ② Photoelectric/proximity sensor (NPN type) ③ Sequencer transistor output (open-collector type) ④ Sequencer contact output (with a minimum load of approx. 5 V DC/1 mA)

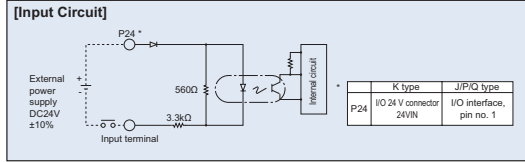

### Input section External input specifications (PNP specifications)

Item	Specifications
Input power supply	24 V DC $\pm 10\%$
Input current	7 mA/circuit
On/Off voltage	On voltage...Min. 8 V DC, Off voltage...Max. 19 V DC
Insulation method	Photocoupler insulation
External devices	① No-voltage contact (with a minimum load of approx. 5 V DC/1 mA) ② Photoelectric/proximity sensor (PNP type) ③ Sequencer transistor output (open-collector type) ④ Sequencer contact output (with a minimum load of approx. 5 V DC/1 mA)

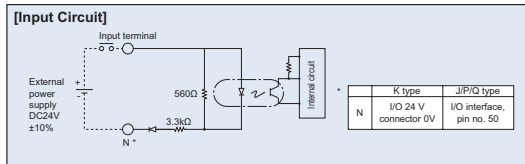

### Output section External input specifications (NPN specifications)

Item	Specifications
Load voltage	24 V DC
Maximum load current	100 mA/point, 400 mA peak (total current)
Leak current	Max. 0.1 mA/point
Insulation method	Photocoupler insulation
External devices	① Miniature relay, ② Sequencer input unit

Uses TD62084 (or equivalent).

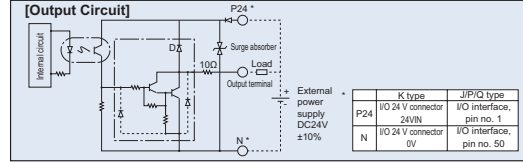

### Output section External input specifications (PNP specifications)

Item	Specifications
Load voltage	24 V DC
Maximum load current	100 mA/point, 400 mA/8 ports (Note)
Leak current	Max. 0.1 mA/point
Insulation method	Photocoupler insulation
External devices	① Miniature relay, ② Sequencer input unit

Uses TD62784 (or equivalent).

(Note) The maximum total load current for every 8 ports from output port no. 300 is limited to 400 mA. (The total maximum load current for output port no. 300 + n to no. 300 + n + 7 is 400 mA, where n = 0 or a multiple of 8.

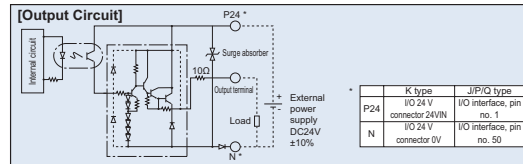

## I/O Signal Chart

### Standard I/O Signal Chart (if N1 or P1 was selected)

Pin No.	Category	Port No.	Standard Setting
1		—	(I/P/Q types: 24V connection; K type: NC)
2		000	Program start
3		001	General-purpose input
4		002	General-purpose input
5		003	General-purpose input
6		004	General-purpose input
7		005	General-purpose input
8		006	General-purpose input
9		007	Program specification (PRG No. 1)
10		008	Program specification (PRG No. 2)
11		009	Program specification (PRG No. 4)
12		010	Program specification (PRG No. 8)
13		011	Program specification (PRG No. 10)
14		012	Program specification (PRG No. 20)
15		013	Program specification (PRG No. 40)
16		014	General-purpose input
17	Input	015	General-purpose input
18		016	General-purpose input
19		017	General-purpose input
20		018	General-purpose input
21		019	General-purpose input
22		020	General-purpose input
23		021	General-purpose input
24		022	General-purpose input
25		023	General-purpose input
26		024	General-purpose input
27		025	General-purpose input
28		026	General-purpose input
29		027	General-purpose input
30		028	General-purpose input
31		029	General-purpose input
32		030	General-purpose input
33		031	General-purpose input
34		300	Alarm output
35		301	Ready output
36		302	Emergency stop output
37		303	General-purpose output
38		304	General-purpose output
39		305	General-purpose output
40		306	General-purpose output
41		307	General-purpose output
42	Output	308	General-purpose output
43		309	General-purpose output
44		310	General-purpose output
45		311	General-purpose output
46		312	General-purpose output
47		313	General-purpose output
48		314	General-purpose output
49		315	General-purpose output
50		—	(I/P/Q types: 0V connection; K type: NC)

### Expansion I/O Signal Chart (if N1 or P1 was selected)

Pin No.	Category	Standard Setting
1		(I/P/Q types: 24V connection; K type: NC)
2		General-purpose input
3		General-purpose input
4		General-purpose input
5		General-purpose input
6		General-purpose input
7		General-purpose input
8		General-purpose input
9		General-purpose input
10		General-purpose input
11		General-purpose input
12		General-purpose input
13		General-purpose input
14		General-purpose input
15		General-purpose input
16		General-purpose input
17	Input	General-purpose input
18		General-purpose input
19		General-purpose input
20		General-purpose input
21		General-purpose input
22		General-purpose input
23		General-purpose input
24		General-purpose input
25		General-purpose input
26		General-purpose input
27		General-purpose input
28		General-purpose input
29		General-purpose input
30		General-purpose input
31		General-purpose input
32		General-purpose input
33		General-purpose input
34		General-purpose output
35		General-purpose output
36		General-purpose output
37		General-purpose output
38		General-purpose output
39		General-purpose output
40		General-purpose output
41		General-purpose output
42	Output	General-purpose output
43		General-purpose output
44		General-purpose output
45		General-purpose output
46		General-purpose output
47		General-purpose output
48		General-purpose output
49		General-purpose output
50		(I/P/Q types: 0V connection; K type: NC)

### Expansion I/O Signal Chart (if N2 or P2 was selected)

Pin No.	Category	Standard Setting
1		(I/P/Q types: 24V connection; K type: NC)
2		General-purpose input
3		General-purpose input
4		General-purpose input
5		General-purpose input
6		General-purpose input
7		General-purpose input
8		General-purpose input
9	Input	General-purpose input
10		General-purpose input
11		General-purpose input
12		General-purpose input
13		General-purpose input
14		General-purpose input
15		General-purpose input
16		General-purpose input
17		General-purpose input
18		General-purpose output
19		General-purpose output
20		General-purpose output
21		General-purpose output
22		General-purpose output
23		General-purpose output
24		General-purpose output
25		General-purpose output
26		General-purpose output
27		General-purpose output
28		General-purpose output
29		General-purpose output
30		General-purpose output
31		General-purpose output
32		General-purpose output
33		General-purpose output
34	Output	General-purpose output
35		General-purpose output
36		General-purpose output
37		General-purpose output
38		General-purpose output
39		General-purpose output
40		General-purpose output
41		General-purpose output
42		General-purpose output
43		General-purpose output
44		General-purpose output
45		General-purpose output
46		General-purpose output
47		General-purpose output
48		General-purpose output
49		General-purpose output
50		(I/P/Q types: 0V connection; K type: NC)

■PX (large-capacity) type/QX (large-capacity global) type

The external dimensions of the X-SEL PX/QX controllers vary depending on the type (arm length) of SCARA robot that is connected, number of axes, whether or not an expansion I/O is installed and the type of direct-coupled axes. Refer to the drawing for the controller with the appropriate number selected from the following table.

SCARA robot		Controller							
Type	Arm length	Large-capacity type (PX)				Large-capacity global type (QX)			
		SCARA only (PX4)		SCARA + direct-coupled axis (PX5/PX6)		SCARA only (QX4)		SCARA + direct-coupled axis (QX5/QX6)	
		Without expansion I/O	With expansion I/O	Without expansion I/O	With expansion I/O	Without expansion I/O	With expansion I/O	Without expansion I/O	With expansion I/O
Standard type	250-600	Dimensional diagram ①	Dimensional diagram ②	Dimensional diagram ③	Dimensional diagram ④	Dimensional diagram ⑤	Dimensional diagram ⑥	Dimensional diagram ⑦	Dimensional diagram ⑧
Cleanroom type				(※2)	(※2)			(※2)	(※2)
Wall-mount type	700-800	Dimensional diagram ③	Dimensional diagram ④	—	—	Dimensional diagram ⑦	Dimensional diagram ⑧	—	—
Ceiling-mount type									
High-speed type	500-600	(※1)	(※1)			(※1)	(※1)		

(※1) Due to a large motor wattage of the SCARA robot, the external dimensions are for the 6-axes configuration, even though only four axes are installed.  
 (※2) With arm length 700/800, the maximum number of connected axes is 5 (SCARA + single axis).

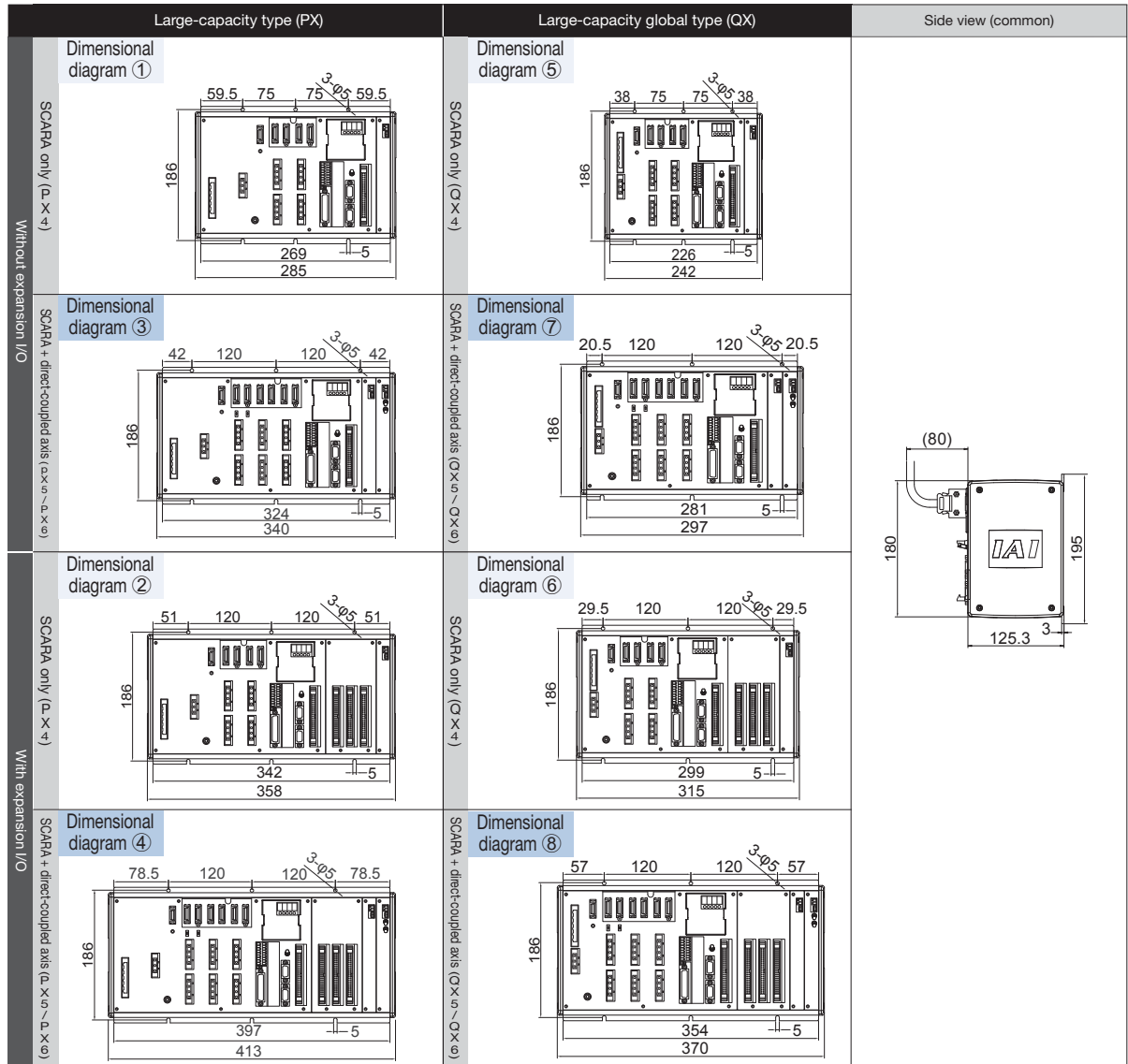

\*All controller types have the same height.

41 XSEL

Options

■ Regenerative resistance unit

Model **REU-1**

Description

This unit converts to heat the regenerative current generated when the motor decelerates. The controller has a built-in regenerative resistor; however, its capacity is insufficient with a vertically positioned axis and a large load. Therefore, a regenerative unit is required. (Refer to the table at the right.)

Specifications

Item	Specifications
Unit dimensions	34 mm (W) × 195 mm (H) × 126 mm (D)
Unit weight	0.9Kg
Built-in regenerative resistor	220Ω, 80 W
Controller connection cable (1 m) (Model CB-ST-REU010)	

Installation Standards

Model	Number of regenerative
NNN	1
NNW	
TNN	3
UNN	
HNN	4
INN	
NNC	3
NSN	
	6016H

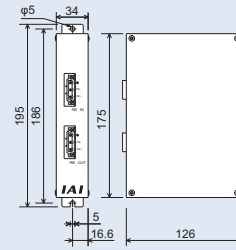

\*The required number listed above is for a single SCARA robot. If single-axis robots are connected as axis 5 or axis 6, refer to the regenerative resistor installation standards for the controller, and then add the required number of regenerative resistors for each single-axis robot that is used.

Example) When operating IX-NNN2515H and ISA-MXM (200W); IX-NNN2515H; Requires 1 ISA-MXM (200W); Requires 1 Therefore, two regenerative resistance units are required.

■ Expansion SIO board (dedicated general-purpose type)

Model/Specifications  
**IA-105-X-MW-A (for RS232C connections)**(main unit + joint cable ①, 2 included)  
**IA-105-X-MW-B (for RS422 connections)**(main unit + joint cable ②, 1 included)  
**IA-105-X-MW-C (for RS485 connections)**(main unit + joint cable ②, 1 included)

Description  
 This board is for serial communications with external devices. This board has two-channel ports, and is compatible with three communication formats using the supplied joint cable.

Joint cable ① Model: CB-ST-232J001

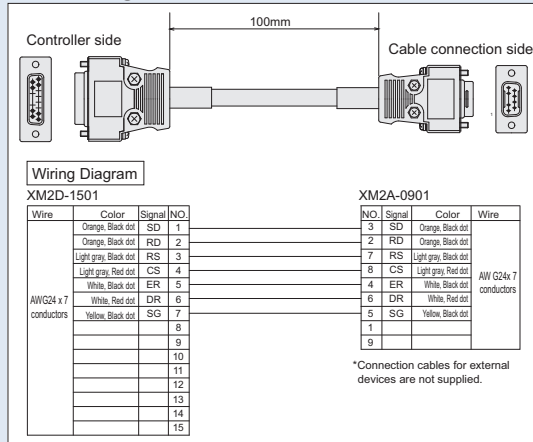

Joint cable ② Model: CB-ST-422J010

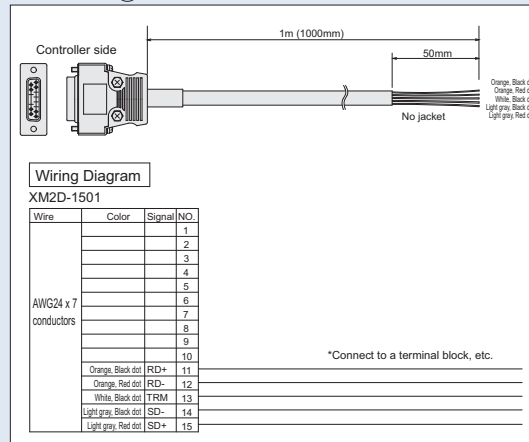

■ DeviceNet connection board

This is the board for connecting the XSEL controller to DeviceNet.

Item	Specifications														
Number of I/O points	1 board: 256 input points/256 output points *Only 1 board can be installed.														
Communication standard	Interface module certified under DeviceNet 2.0 (certification to be obtained) Group 2 only server Insulated node operating on network power supply														
Communication specifications	Master/slave connection Bit strobe Polling Cyclic														
Baud rate	500 Kbps/250 Kbps/125 Kbps (selectable with DIP switch)														
Communication cable length	<table border="1"> <thead> <tr> <th>Baud rate</th> <th>Max. network length</th> <th>Max. branch length</th> <th>Total branch length</th> </tr> </thead> <tbody> <tr> <td>500 Kbps</td> <td>100m</td> <td rowspan="3">6m</td> <td>39m</td> </tr> <tr> <td>250 Kbps</td> <td>250m</td> <td>78m</td> </tr> <tr> <td>125 Kbps</td> <td>500m</td> <td>156m</td> </tr> </tbody> </table>	Baud rate	Max. network length	Max. branch length	Total branch length	500 Kbps	100m	6m	39m	250 Kbps	250m	78m	125 Kbps	500m	156m
Baud rate	Max. network length	Max. branch length	Total branch length												
500 Kbps	100m	6m	39m												
250 Kbps	250m		78m												
125 Kbps	500m		156m												
Note: When using the thick cable for DeviceNet															
Communication power supply	24 V DC (supplied from DeviceNet)														
Communication power supply consumption current	60 mA or more														
Number of reserved nodes	1 node														
Connector	MSTBA2.5/5-G.08AUM manufactured by Phoenix Contact (*1)														

(\*1) Cable-side connector (SMSTB2.5/5-ST-5.08AU manufactured by Phoenix Contact) is a standard accessory.

■ CC-Link connection board

This is the board for connecting the XSEL controller to CC-Link.

Item	Specifications												
Number of I/O points	Remote device 1 board: 256 input points/256 output points *Only 1 board can be installed.												
Communication standard	CC-Link Ver. 1.10 (certified)												
Baud rate	10 Mbps/5 Mbps/2.5 Mbps/625 Kbps/156 Kbps (selectable with rotary switch)												
Communication method	Broadcast polling method												
Synchronization method	Frame synchronization method												
Encoding method	NRZI												
Transmission path type	Bus format (EIA-485 (RS485)-compliant)												
Transmission format	HDLC-compliant												
Error control system	CRC (X <sup>16</sup> +X <sup>12</sup> +X <sup>5</sup> +X <sup>1</sup> )												
Number of reserved stations	1 to 3 stations (remote device stations)												
Communication cable length	<table border="1"> <thead> <tr> <th>Baud rate (bps)</th> <th>10M</th> <th>5M</th> <th>2.5M</th> <th>625K</th> <th>156K</th> </tr> </thead> <tbody> <tr> <td>Cable length (m)</td> <td>100</td> <td>160</td> <td>400</td> <td>900</td> <td>1200</td> </tr> </tbody> </table>	Baud rate (bps)	10M	5M	2.5M	625K	156K	Cable length (m)	100	160	400	900	1200
Baud rate (bps)	10M	5M	2.5M	625K	156K								
Cable length (m)	100	160	400	900	1200								
Connector (controller side)	MSTBA2.5/5-G.08-AUM manufactured by Phoenix Contact (*1)												

(\*1) Cable-side connector (SMSTB2.5/5-ST-5.08AU manufactured by Phoenix Contact) is a standard accessory.

Teaching pendant conforming to ANSI standards/CE mark (dedicated general-purpose type)

**Model** **SEL-T**  
**SEL-TD** (ANSI-compliant)

**Dimensions**

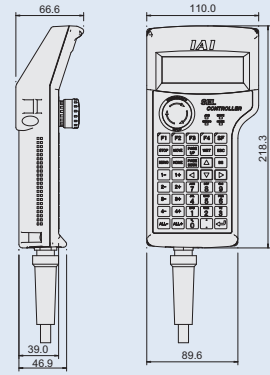

**Features** The splash-proof type complies to protection rating IP54. Usability has been enhanced by incorporating dedicated keys programmed for each function. In addition, SEL-TD is equipped with a 3-position enable switch and supports ANSI standards.

**Specifications**

Item	Specifications
Operating temperature/humidity	Temperature: 0-40 °C, humidity: 30-85%RH or less (no condensation)
Protective structure	IP54 (excluding the cable connector)
Weight	400g or less (excluding the cable)
Cable length	5 m
Display	32-character x 8-row LCD display
Safety rating	CE mark, ANSI standards (*)

(\*) ANSI standards are supported only by SEL-TD.

**Note**

\* When operating the controller described in this catalog, be sure to use Ver. 1.11 or later.

Computer software (Windows only)

**Model** **IA-101-X-MW** (DOS/V version)  
\*Contact us for information about the PC98 version.

**Note**

\*In order to operate the controllers described in this catalog, use software of Ver. 7.5.0.0 or later.  
\*Use model IA-101-XA-MW when a controller conforming to Safety Category 4 is required.

**Features** This startup assistance software provides functions for program/position input, test operation and monitoring. The functions needed for debugging have been enhanced significantly to help reduce startup time.

- Description**
- Software (CD-ROM)
  - (Compatible with Windows 98, NT, 2000, ME and XP)
  - Computer connection cable (5 m) + emergency stop box (Model CB-ST-E1MW050-EB)

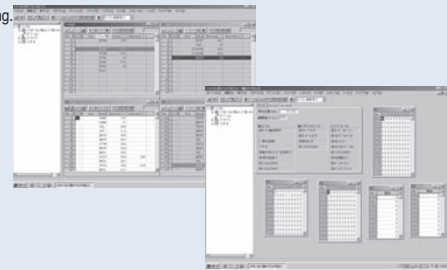

Computer connection cable (Model CB-ST-E1MW050)

**Note**

When ordering a computer connection cable separately for maintenance purposes, specify model CB-ST-E1MW050 for only the cable. When ordering a computer connection cable and an emergency stop box as a set, specify model CB-ST-E1MWO50-EB.

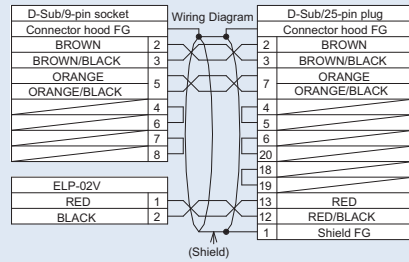
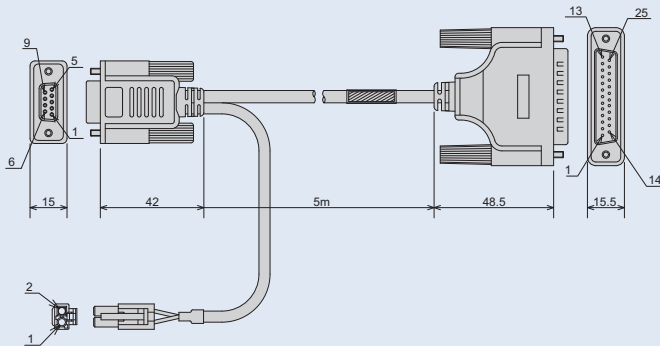

**Computer software compatible with Safety Category 4 (XSEL-Q/QX only)**

**Model** IA-101-XA-MW (DOS/V version)

**Features** This startup assistance software provides functions for program/position input, test operation and monitoring. The functions needed for debugging have been enhanced significantly to help reduce startup time. In addition, the computer connection cable provides a redundant emergency stop circuit, and complies with Safety Category 4.

\*Cannot be used with XSEL-J/JX/K/KE/KX/P/PX.

**Description** Software (CD-ROM)  
 (Accessories) \*Compatible with Windows 98, NT, 2000, ME and XP  
 Computer connection cable (5 m) + emergency stop box (Model CB-ST-A1MW050-EB)

**Note**  
 When ordering a computer connection cable separately for maintenance purposes, specify model CB-ST-A1MW050 for only the cable. When ordering a computer connection cable and an emergency stop box as a set, specify model CB-ST-A1MW050-EB.

**Dimensions** Computer connection cable (Model CB-ST-A1MW050)

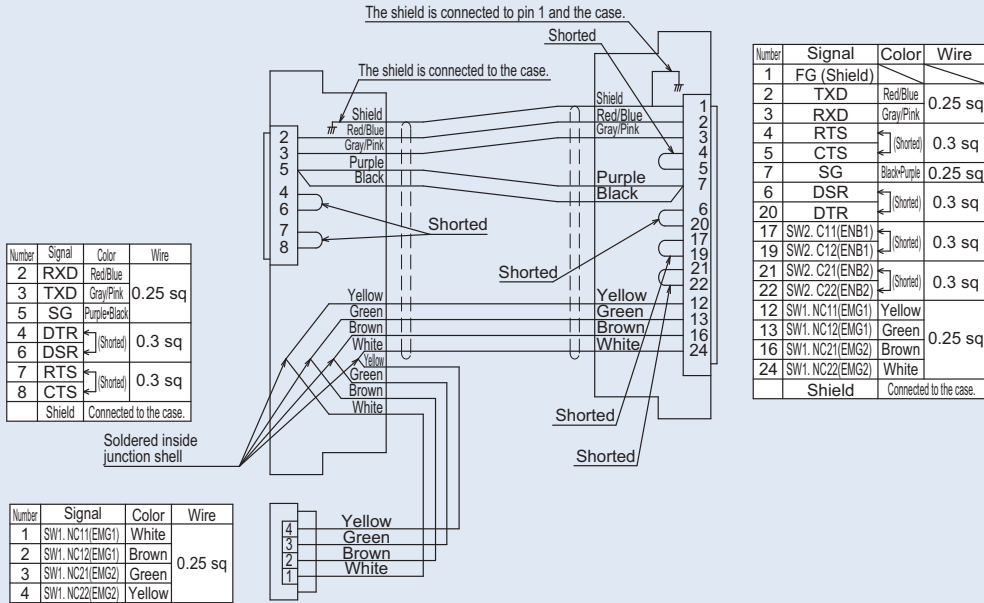
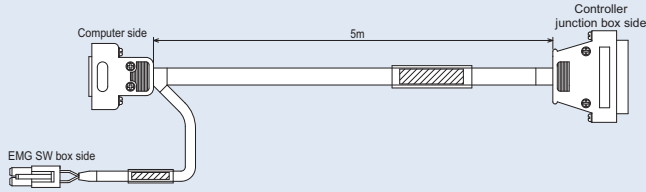

**USB computer software**

**Model** IA-101-X-USBMW

**Features** A USB conversion adapter is connected to the RS232C cable to enable use with a USB port of a computer.

**Description** Software (CD-ROM)  
 \*Compatible with Windows 98, NT, 2000, ME and XP  
 Computer connection cable (5 m) + emergency stop box + USB conversion adapter + USB cable (1 m) \*Cannot be used with XSEL-Q/QX.

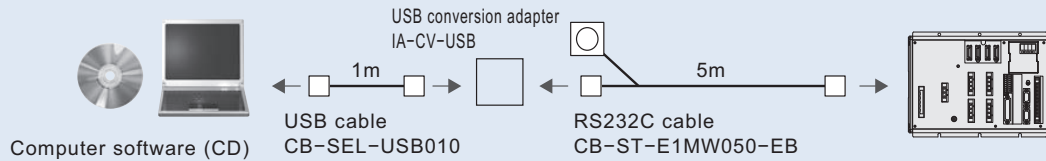

# Reference Acceleration/Deceleration Settings

SCARA robots cannot operate continuously at the maximum speed and maximum acceleration mentioned in the catalog. When operating at the maximum acceleration, provide a stopping time based on the reference range for continuous operation duty in the graphs. If the robot must operate continuously, it should operate with an acceleration setting in the reference range for continuous operation in the graphs of reference acceleration/deceleration settings.

## •With arm length 250/300/350

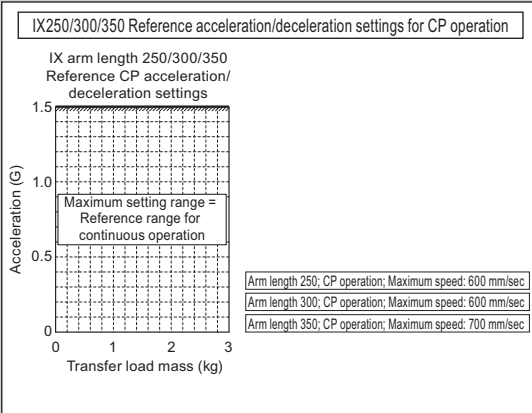
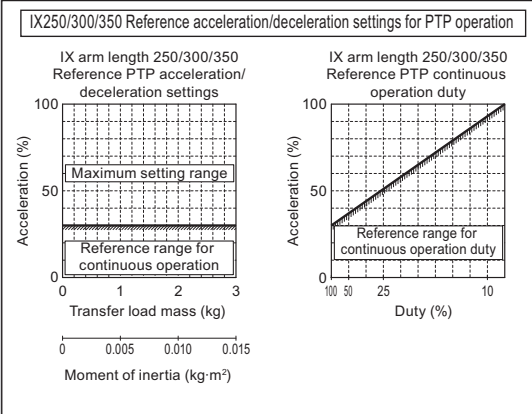

## •With arm length 500/600

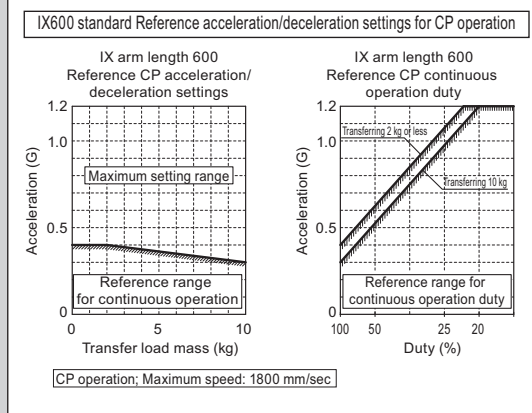
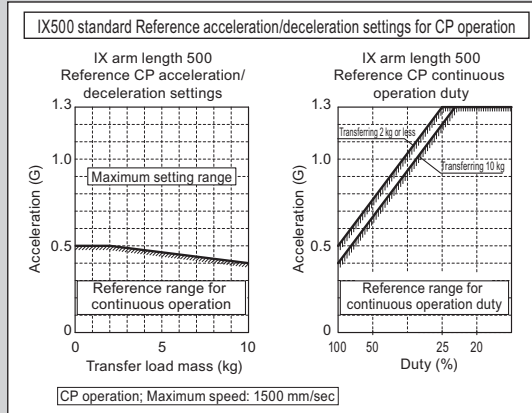
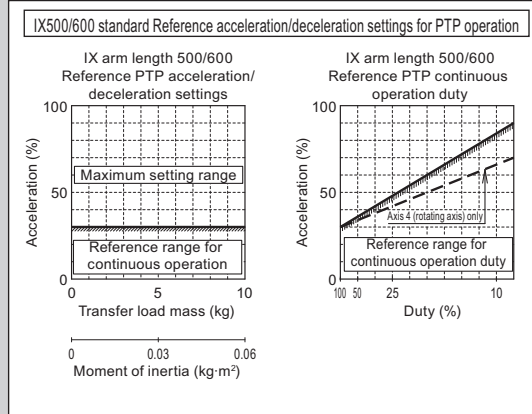

(Caution)

- 1) With PTP operation, be sure to use the WGHT command in the program, and run the operation with the load and inertial moment specified. SCARA high-speed products operate at 100% of the maximum acceleration allowable for operation with each transfer mass. Operating times differ with different transfer masses, even with the same acceleration and speed settings.
- 2) To adjust the acceleration, start from the appropriate reference range for continuous operation, and then gradually raise the setting.
- 3) In an overload error occurs, lower the acceleration setting as appropriate, or provide a stopping time based on the reference for continuous operation duty.
- 4)  $Duty (\%) = \frac{\text{Operating time}}{\text{Operating time} + \text{Stopped time}} \times 100$
- 5) When moving the robot horizontally at high speed, operate the vertical axis as close as possible to the top end.
- 6) The inertial moment and transfer mass should not exceed the maximum allowed.
- 7) The transfer load refers to the inertial moment and mass of the center of rotation for axis 4.
- 8) Operate the robot while maintaining an appropriate acceleration for the mass and inertial moment. Failure to do so may cause drive parts to wear prematurely or may result in damage or vibrations.
- 9) If the inertial moment of the load is large, vibrations may occur in the vertical axis, depending on the position of the axis. If vibrations occur, lower the acceleration as appropriate.

With arm length 700/800

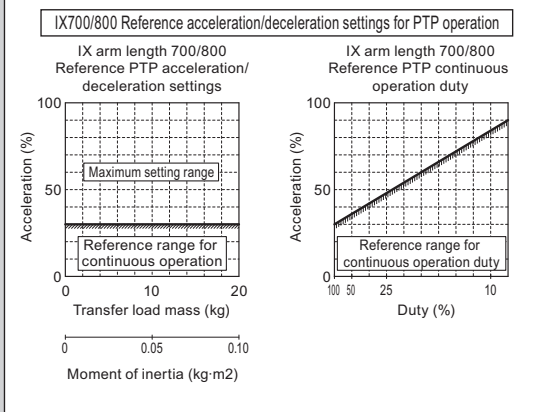

With high-speed type (arm length 500/600)

