

ISDBCR-ESD

Single-axis robot for cleanroom/Electrostatic discharge specification
Type S (W: 90 mm)/Type M (W: 120 mm)/Type L (W: 150 mm)

ISPDBCR-ESD

Single-axis robot for cleanroom/Electrostatic discharge specification
Type S (W: 90 mm)/Type M (W: 120 mm)/Type L (W: 150 mm) **High precision specification**



Model Specification Items	Series	Type	Encoder type	Motor type	Lead	Stroke	Applicable controller	Cable length	ESD	Options
ISDBCR: Standard specification	S: Small	A: Absolute	60: 60W	40: 40mm	10: 10mm	100: 100mm	T1: XSEL-J/K	N: None	Refer to the options table below.	
ISDBCR: M: Medium specification	M: Medium	M: Medium	100: 100W	30: 30mm	8: 8mm	?	T2: SCON	S: 3m		
ISPDBCR: High precision specification	L: Large	I: Incremental	200: 200W	20: 20mm	5: 5mm	1300: 1300mm (in 50mm increments)	SSEL	M: 5m		
			400: 400W	16: 16mm	4: 4mm		XSEL-P/Q	X□□: Specified length		

* Refer to P. 10 for the details of items comprising the model number.

Model Number/Specification

*1.0G=9800mm/sec²

Model number	Encoder type	Motor output (W)	Lead (mm)	Stroke in 50mm increments (mm)	Speed (mm/s)	Acceleration (Note 1)				Payload (Note 1)				Rated thrust (N)	Suction flow rate (Nl/min)
						Horizontal (G)		Vertical (G)		Horizontal (Kg)		Vertical (Kg)*			
						Rated	Maximum	Rated	Maximum	Rated acceleration	Maximum acceleration	Rated acceleration	Maximum acceleration		
ISDBCR[ISPDBCR]-S-①-60-16-②-③-④-ESD-⑤	Absolute Incremental	60	16	100~800	1~960	0.4	1	0.4	0.8	13	4.5	3	2	53.1	60
ISDBCR[ISPDBCR]-S-①-60-8-②-③-④-ESD-⑤			8		1~480	0.4	0.7	0.4	0.6	27	12	6	5	106.1	30
ISDBCR[ISPDBCR]-S-①-60-4-②-③-④-ESD-⑤			4		1~240	0.2	0.5	0.2	0.4	55	30	14	12	212.3	15
ISDBCR[ISPDBCR]-M-①-100-30-②-③-④-ESD-⑤	Absolute Incremental	100	30	100~1100	1~1800	0.4	1	0.4	1	15	4	2	1.2	56.6	180
ISDBCR[ISPDBCR]-M-①-100-20-②-③-④-ESD-⑤			20		1~1200	0.4	1	0.4	1	23	8	4	2.5	84.9	120
ISDBCR[ISPDBCR]-M-①-100-10-②-③-④-ESD-⑤			10		1~600	0.4	0.7	0.4	0.6	45	20	10	7	169.8	50
ISDBCR[ISPDBCR]-M-①-100-5-②-③-④-ESD-⑤	Absolute Incremental	200	5	100~1100	1~300	0.2	0.5	0.2	0.4	85	45	20	15	339.7	20
ISDBCR[ISPDBCR]-M-①-200-30-②-③-④-ESD-⑤			30		1~1800	0.4	1	0.4	1	30	12	6	3	113.9	180
ISDBCR[ISPDBCR]-M-①-200-20-②-③-④-ESD-⑤			20		1~1200	0.4	1	0.4	1	45	16	10	5	170.9	120
ISDBCR[ISPDBCR]-M-①-200-10-②-③-④-ESD-⑤	Absolute Incremental	200	10	100~1100	1~600	0.4	0.7	0.4	0.6	90	40	20	15	341.8	50
ISDBCR[ISPDBCR]-M-①-200-5-②-③-④-ESD-⑤			5		1~300	0.2	0.5	0.2	0.4	110	80	40	30	683.6	20
ISDBCR[ISPDBCR]-L-①-200-40-②-③-④-ESD-⑤			40		1~1800	0.4	1	0.4	1	15	7	2.5	2	85.5	180
ISDBCR[ISPDBCR]-L-①-200-20-②-③-④-ESD-⑤	Absolute Incremental	200	20	100~1300	1~1200	0.4	1	0.4	1	45	15	9	5	170.9	120
ISDBCR[ISPDBCR]-L-①-200-10-②-③-④-ESD-⑤			10		1~600	0.4	0.7	0.4	0.6	90	40	20	14	341.8	50
ISDBCR[ISPDBCR]-L-①-400-40-②-③-④-ESD-⑤			40		1~1800	0.4	1	0.4	1	40	17	8	5	169.6	180
ISDBCR[ISPDBCR]-L-①-400-20-②-③-④-ESD-⑤	Absolute Incremental	400	20	100~1300	1~1200	0.4	1	0.4	1	90	30	20	10	339.1	120
ISDBCR[ISPDBCR]-L-①-400-10-②-③-④-ESD-⑤			10		1~600	0.4	0.7	0.4	0.6	120	60	40	30	678.3	50

*In the above model numbers, ① indicates the encoder type, ② indicates the stroke, ③ indicates the applicable controller, ④ indicates the cable length, and ⑤ indicates the option(s).

Option

Name	Model number	Reference page	Name	Model number	Reference page
Cable exit from the left	A1S	→P11	Home limit switch	L	→P11
Cable exit from the rear left	A1E	→P11	Home limit switch on the opposite side	LL	→P11
Cable exit from the right	A3S	→P11	Master axis specification	LM	→P12
Cable exit from the rear right	A3E	→P11	Master axis specification (sensor on the opposite side)	LLM	→P12
AQ seal (standard feature)	AQ	→P11	Non-motor side specification	NM	→P12
Brake	B	→P11	Guide with ball retention mechanism	RT	→P12
Creep sensor	C	→P11	Slave axis specification	S	→P12
Creep sensor on the opposite side	CL	→P11	High straightness, precision specification	ST	→P13
			Suction tube joint on the opposite side	VR	→P12

Common Specifications

Positioning repeatability (Note 2)	±0.01mm (±0.005mm)
Drive method (Note 3)	S type: Ball screw ø12mm, rolled C10 [equivalent to rolled C5] M type: Ball screw ø16mm, rolled C10 [equivalent to rolled C5] L type: Ball screw ø20mm, rolled C10 [equivalent to rolled C5]
Lost Motion (Note 4)	0.05mm [0.02mm] max.
Dynamic allowable load moment (Note 5)	S type: Ma: 28.4N·m Mb: 40.2N·m Mc: 65.7N·m M type: Ma: 69.6N·m Mb: 99.0N·m Mc: 161.7N·m L type: Ma: 104.9N·m Mb: 149.9N·m Mc: 248.9N·m
Overhang load length	S type: Ma direction: 450mm max. Mb, Mc directions: 450mm max. M type: Ma direction: 600mm max. Mb, Mc directions: 600mm max. L type: Ma direction: 750mm max. Mb, Mc directions: 750mm max.
Dynamic straightness (Note 6)	0.02mm/m max.
Base	Material: Aluminum, with white alumite treatment
Applicable controller	T1: XSEL-J/K T2: XSEL-P/Q, SSEL, SCON
Cable length (Note 7)	N: None, S: 3m, M: 5m, X□□: Specified length
Grease	Low dust-raising grease (for ball screw and guide)
Cleanliness degree	Class 10 (0.1µm per 1cf)
Suction tube joint	Quick connect joint, applicable tube outer diameter ø12mm

Applicable Controller Specifications

Applicable Controller	Maximum number of controlled axes	Connectable encoder type	Operating method	Power-supply voltage	Reference page
X-SEL-P/Q	6 axes	Absolute/incremental	Program	Single/three-phase 200 VAC	→P56
X-SEL-J/K	4 axes			Single-phase 100/200 VAC	→P56
SSEL	2 axes			→P56	
SCON	1 axis			Positioner pulse train control	Single-phase 200 VAC for 400W motor spec →P56



(Note 1) Refer to P. 9 for the relationship of acceleration and payload.
(Notes 2, 3, 4) The values in [] apply to the ISPDBCR series. Other specification values apply commonly to the ISDBCR and ISPDBCR.
(Note 5) When the traveling life is 10,000km.
(Note 6) The value of dynamic straightness is when the high straightness, precision specification (option) is specified.
(Note 7) The maximum cable length is 30m. Specify a desired length in meters. (Example. X08 = 8m)

ISDBCR-ESD/ISPDBCR-ESD

A1

Sold & Serviced By:

ELECTROMATE

Toll Free Phone (877) SERV098

Toll Free Fax (877) SERV099

www.electromate.com

sales@electromate.com

Type S (Small) (60W)

SE: Stroke End
ME: Mechanical End

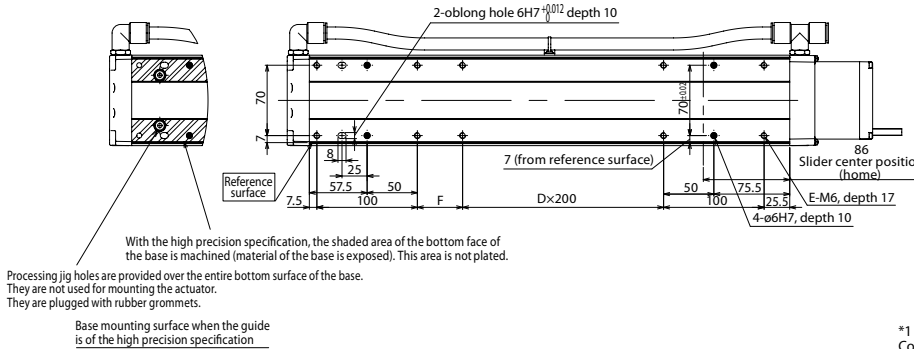
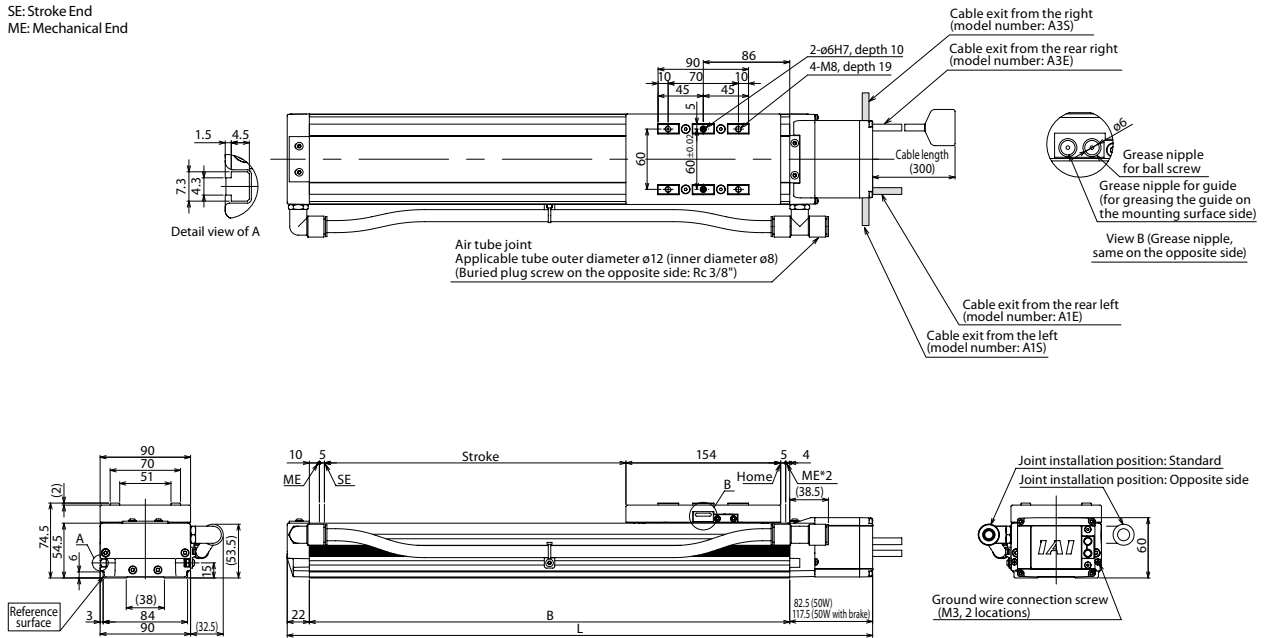

*1 Connect the motor cable and encoder cable. Refer to P. 57 for the cables.

*2 During the home return, the slider moves to the ME, so pay attention not to let the slider hit surrounding parts.

* Take note that to change the home direction, the actuator must be returned to us for adjustment.

■ Dimensions, Mass and Maximum Speed by Stroke

*If the brake is equipped, the mass increases by 0.2kg. *The maximum speed (mm/s) varies depending on the stroke.

Stroke	100	150	200	250	300	350	400	450	500	550	600	650	700	750	800	
L	without brake	382.5	432.5	482.5	532.5	582.5	632.5	682.5	732.5	782.5	832.5	882.5	932.5	982.5	1032.5	1082.5
	with brake	417.5	467.5	517.5	567.5	617.5	667.5	717.5	767.5	817.5	867.5	917.5	967.5	1017.5	1067.5	1117.5
B	278	328	378	428	478	528	578	628	678	728	778	828	878	928	978	
D	0	0	0	0	1	1	1	1	2	2	2	2	3	3	3	
E	8	8	8	8	10	10	10	10	12	12	12	12	14	14	14	
F	45	95	145	195	45	95	145	195	45	95	145	195	45	95	145	
Mass (kg)	4.2	4.5	4.9	5.2	5.6	6.0	6.3	6.7	7.0	7.4	7.8	8.1	8.5	8.9	9.2	
Maximum speed (mm/s)	Lead 16	960								920	795	690	610	540	480	
	Lead 8	480								460	400	345	305	270	240	
	Lead 4	240								230	200	170	150	135	120	

A2 ISDBCR-ESD/ISPBCR-ESD

Type M (Medium) (100W/200W)

SE: Stroke End
ME: Mechanical End

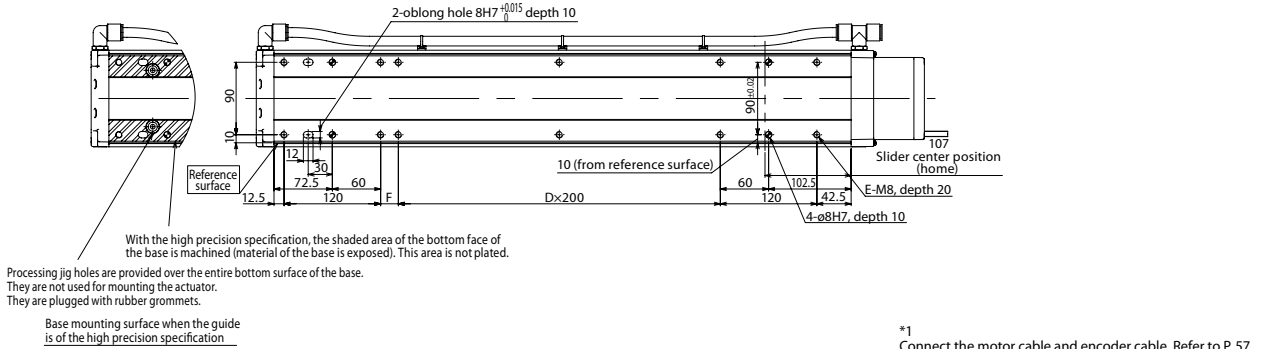
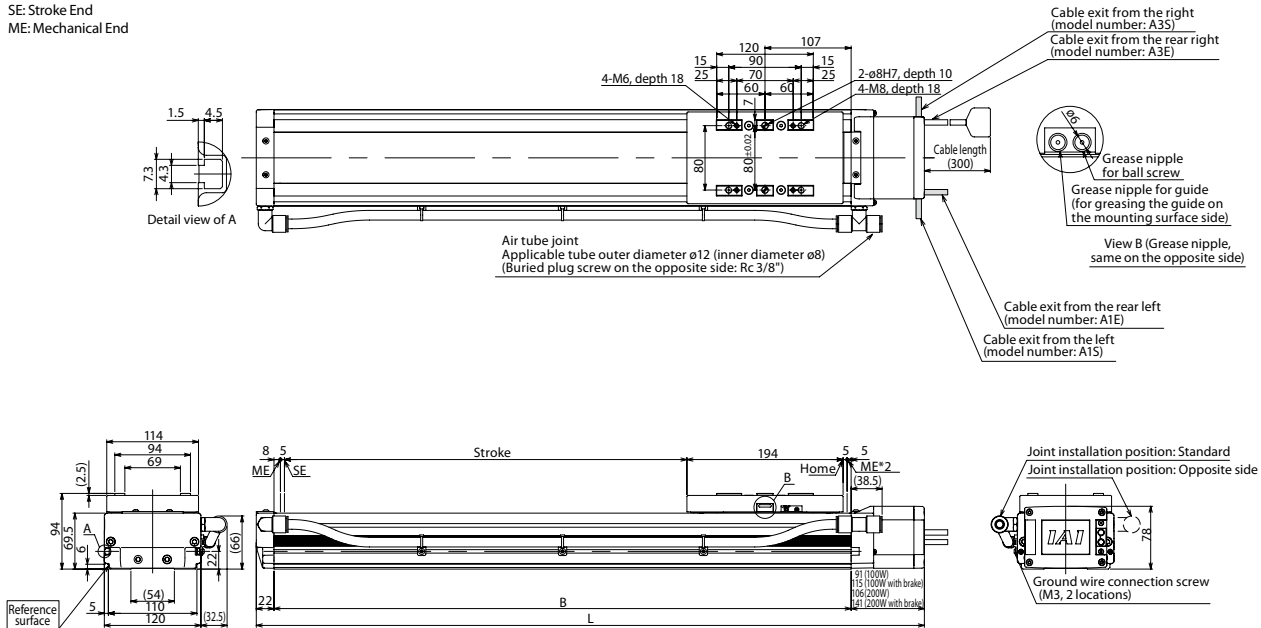

- *1 Connect the motor cable and encoder cable. Refer to P. 57 for the cables.
- *2 During the home return, the slider moves to the ME, so pay attention not to let the slider hit surrounding parts.
- * Take note that to change the home direction, the actuator must be returned to us for adjustment.

■ Dimensions, Mass and Maximum Speed by Stroke

*If there is a brake, the mass increases by 0.3 kg for the 100-W type and by 0.4 kg for the 200-W type. *The maximum speed (mm/s) varies depending on the stroke.

Stroke	100	150	200	250	300	350	400	450	500	550	600	650	700	750	800	850	900	950	1000	1050	1100		
L	100W	without brake	430	480	530	580	630	680	730	780	830	880	930	980	1030	1080	1130	1180	1230	1280	1330	1380	1430
		with brake	454	504	554	604	654	704	754	804	854	904	954	1004	1054	1104	1154	1204	1254	1304	1354	1404	1454
	200W	without brake	445	495	545	595	645	695	745	795	845	895	945	995	1045	1095	1145	1195	1245	1295	1345	1395	1445
		with brake	480	530	580	630	680	730	780	830	880	930	980	1030	1080	1130	1180	1230	1280	1330	1380	1430	1480
B		317	367	417	467	517	567	617	667	717	767	817	867	917	967	1017	1067	1117	1167	1217	1267	1317	
D		0	0	0	0	1	1	1	1	2	2	2	2	3	3	3	4	4	4	4	4	5	
E		8	8	8	8	10	10	10	10	12	12	12	12	14	14	14	14	16	16	16	16	18	
F		22	72	122	172	22	72	122	172	22	72	122	172	22	72	122	172	22	72	122	172	22	
Mass (kg)	100W	7.6	8.2	8.8	9.5	10.1	10.7	11.3	12.0	12.6	13.2	13.9	14.5	15.1	15.7	16.4	17.0	17.6	18.2	18.9	19.5	20.1	
	200W	8.0	8.6	9.2	9.9	10.5	11.1	11.7	12.4	13.0	13.6	14.3	14.9	15.5	16.1	16.8	17.4	18.0	18.6	19.3	19.9	20.5	
Maximum speed (mm/s)	Lead 30	1800																					
	Lead 20	1200																					
	Lead 10	600																					
	Lead 5	300																					
														1630	1440	1280	1150	1035	935	850	780	715	660
														1085	960	855	765	690	625	570	520	475	440
														545	480	430	380	345	310	285	260	240	220
														270	240	215	190	170	155	140	130	120	110

ISDBCRC-ESD/ISPDBCRC-ESD

A3

Type L (Large) (200W/400W)

SE: Stroke End
ME: Mechanical End

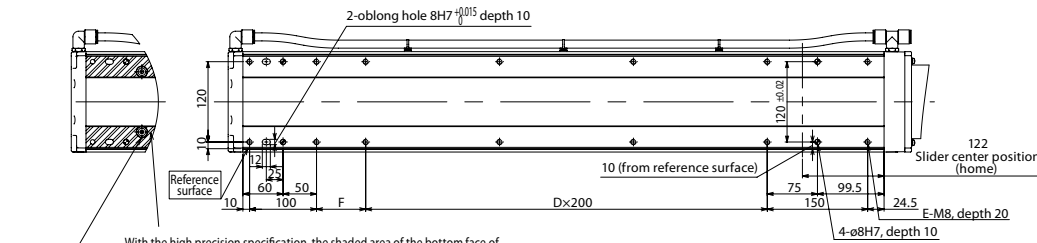
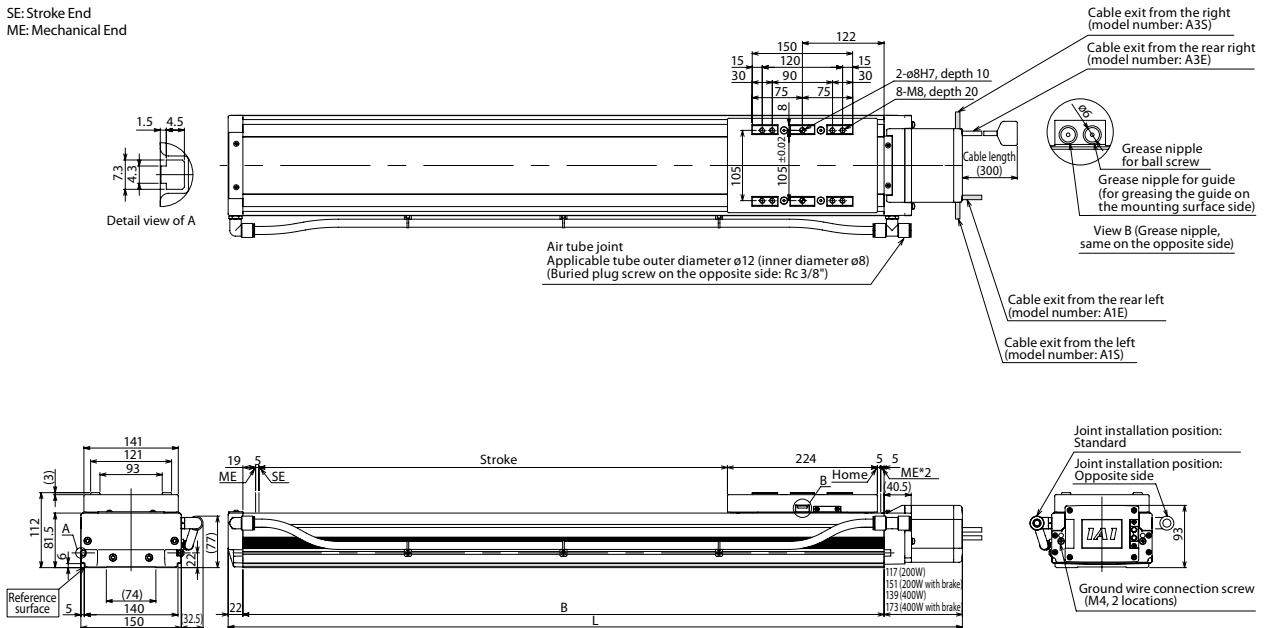

With the high precision specification, the shaded area of the bottom face of the base is machined (material of the base is exposed). This area is not plated.
Processing jig holes are provided over the entire bottom surface of the base. They are not used for mounting the actuator. They are plugged with rubber grommets.
Base mounting surface when the guide is of the high precision specification

- *1 Connect the motor cable and encoder cable. Refer to P. 57 for the cables.
- *2 During the home return, the slider moves to the ME, so pay attention not to let the slider hit surrounding parts.
- * Take note that to change the home direction, the actuator must be returned to us for adjustment.

■ Dimensions, Mass and Maximum Speed by Stroke

*If the brake is equipped, the mass increases by 0.5kg. *The maximum speed (mm/s) varies depending on the stroke.

L	Stroke	Stroke																														
		100	150	200	250	300	350	400	450	500	550	600	650	700	750	800	850	900	950	1000	1050	1100	1150	1200	1250	1300						
200W	without brake	497	547	597	647	697	747	797	847	897	947	997	1047	1097	1147	1197	1247	1297	1347	1397	1447	1497	1547	1597	1647	1697						
	with brake	531	581	631	681	731	781	831	881	931	981	1031	1081	1131	1181	1231	1281	1331	1381	1431	1481	1531	1581	1631	1681	1731						
400W	without brake	519	569	619	669	719	769	819	869	919	969	1019	1069	1119	1169	1219	1269	1319	1369	1419	1469	1519	1569	1619	1669	1719						
	with brake	553	603	653	703	753	803	853	903	953	1003	1053	1103	1153	1203	1253	1303	1353	1403	1453	1503	1553	1603	1653	1703	1753						
B		358	408	458	508	558	608	658	708	758	808	858	908	958	1008	1058	1108	1158	1208	1258	1308	1358	1408	1458	1508	1558						
D		0	0	0	1	1	1	1	2	2	2	2	3	3	3	3	4	4	4	4	5	5	5	5	6	6						
E		8	8	8	10	10	10	10	12	12	12	12	14	14	14	14	16	16	16	16	18	18	18	18	20	20						
F		73.5	123.5	173.5	223.5	273.5	323.5	373.5	423.5	473.5	523.5	573.5	623.5	673.5	723.5	773.5	823.5	873.5	923.5	973.5	1023.5	1073.5	1123.5	1173.5	1223.5	1273.5						
Mass (kg)	200W	11.9	12.7	13.6	14.4	15.3	16.2	17.0	17.9	18.7	19.6	20.4	21.3	22.1	23.0	23.9	24.7	25.6	26.4	27.3	28.1	29.0	29.8	30.7	31.5	32.4						
	400W	12.3	13.1	14.0	14.8	15.7	16.6	17.4	18.3	19.1	20.0	20.8	21.7	22.5	23.4	24.3	25.1	26.0	26.8	27.7	28.5	29.4	30.2	31.1	31.9	32.8						
Maximum speed (mm/s)	Lead 40	1800																		1700	1540	1410	1290	1185	1095	1015	940	875	815			
	Lead 20	1200																		1165	1045	940	850	770	705	645	595	545	505	470	440	410
	Lead 10	600																		585	520	470	425	385	350	320	295	275	255	235	220	205

A4

ISDBCR-ESD/SPDPCR-ESD