

Direct Drive Motor **DD**



High Speed, High Payload, Easy to Adjust, Introducing a Direct Drive Motor Achieving

Features

The Direct Drive Motor is a rotary actuator that directly drives a rotary table with a motor without using any speed reducing mechanism such as a belt or reduction gears.

Eliminating the speed reducing mechanism translates to high speed and excellent response, while the compact actuator lets you reduce the size of your equipment.

1 High Torque, High Payload

The compact actuator can generate high torque, generating a maximum instantaneous torque of 25.2 N·m. Based on a rectangular solid shape of 200 mm x 200 mm in size, an object weighing up to 90 kg can be rotated.

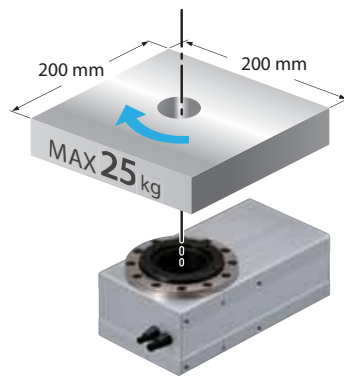

RCS2-RTC12L (reduction ratio 1/30)
Allowable moment of inertia
0.17 kg·m²

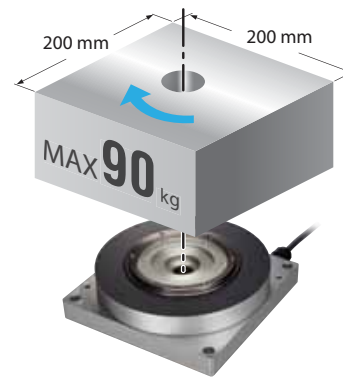

DD-T18S
Allowable moment of inertia
0.60 kg·m²

2 High Speed/High Acceleration/Deceleration

High torque enables high-speed positioning at a maximum speed of 1800 deg/s. Shorter positioning time means shorter cycle time of your equipment, resulting in greater productivity.

<Comparison of Cycle Times>

Operating conditions: When a work part weighing 100 g is placed on an aluminum disc of 300 mm in diameter and 6 mm in thickness and rotated by 180 deg.

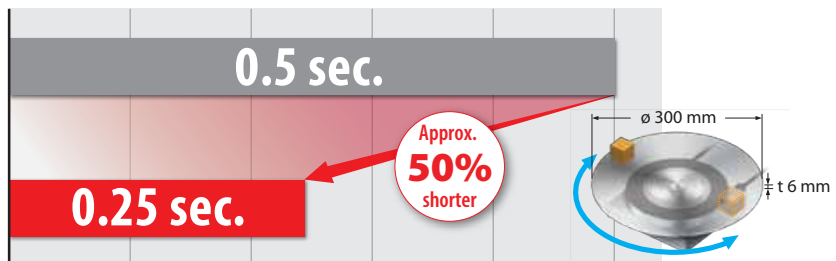

1

and Compact! High Cost Performance.

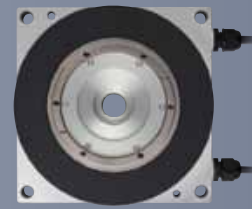

3 Compact Size

Measuring 180 mm in width, 180 mm in depth and 53 mm in height, the actuator is fairly compact in size. As it can be installed even in a small space, you have a greater degree of freedom designing your equipment.

< 70 mm slimmer than the RTC12L type >

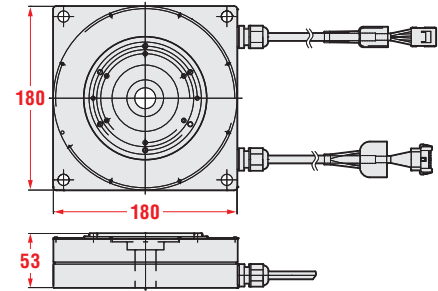
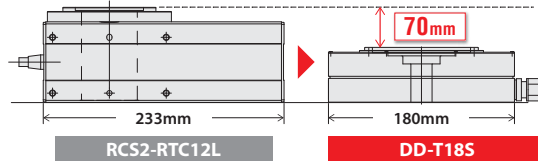

4 Index Type or Multi-rotation Absolute Type Can be Selected

The Direct Drive Motor comes in the index type having an operating range of 0 to 359.999 deg and the multi-rotation absolute type having an operating range of ± 9999 deg. Neither type requires a home return, meaning that once the power has been turned on, the actuator can move directly from the current position. The index type does not need an absolute battery.

	Index type	Multi-rotation absolute type
Range of operation	0 to 359.999 deg	± 9999 deg
Home return	Not required	Not required
Unlimited rotations	Yes	No
Absolute battery	Not required	Required

5 Positioner or Program Type Controller Can be Selected

The controller can be selected from [A] positioner type: dedicated to 1-axis, easy operation and affordable price, and [B] program type: operable up to 8-axis. Please choose according to the configuration or use application.



Positioner type <SCON-CA>

Program type <XSEL>

Application Examples

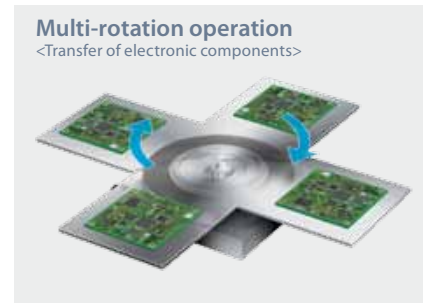
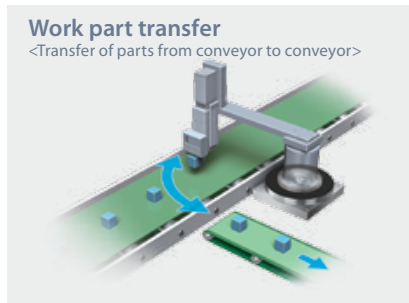
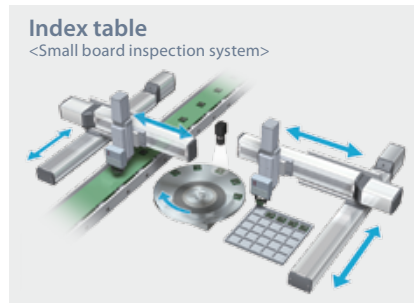

2

DD-T18S

Direct Drive Motor
Actuator width: 180mm Slim type



Model Specification Items

DD Series - **T18S** Type - Encoder type - **200** Motor wattage - **360** Range of operation - **T2** Applicable controller - Cable length

A1: Index type 200: 200W 360: 360 deg T2: SCON-CA XSEL-P/Q XSEL-R/S
AM: Multi-rotation absolute type
N: None S: 3m M: 5m X□□: Specified length

Model/Specification

Model number	Encoder type	Motor wattage (W)	Range of operation (deg)	Speed (Note 1) (deg/s)	Rated torque (N·m)	Maximum instantaneous torque (N·m) (*)	Allowable load inertia (kg·m ²)	Rotor inertia (kg·m ²)
DD-T18S-①-200-360-T2-②	Index type Multi-rotation absolute type	200	360	1 to 1800	8.4	25.2	0.6	0.001984

Legend ① Encoder type ② Cable length (*) The value when installed on an IAI rated heat dissipating plate. (Please see the manual for further details.)

Common Specifications

Drive system	Direct Drive Motor
Positioning repeatability	± 0.0055 deg
Dynamic allowable load moment (Note 2)	80 N·m
Encoder resolution	131072 (17bit/rev)
Allowable thrust load (Note 2)	3400 N
Base	Aluminum
Compatible controller	T2: SCON-CA XSEL-P/Q/R/S
Cable length	N: None, S: 3 m, M: 5 m, X□□: Specified length (Note 3)
Ambient operating temperature/humidity	0 to 40°C, 20 to 85% (Non-condensing)
Mass	5 kg

Run-out of Output Shaft

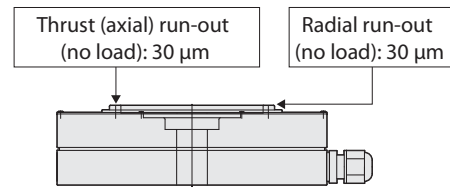

Dimensional Drawing

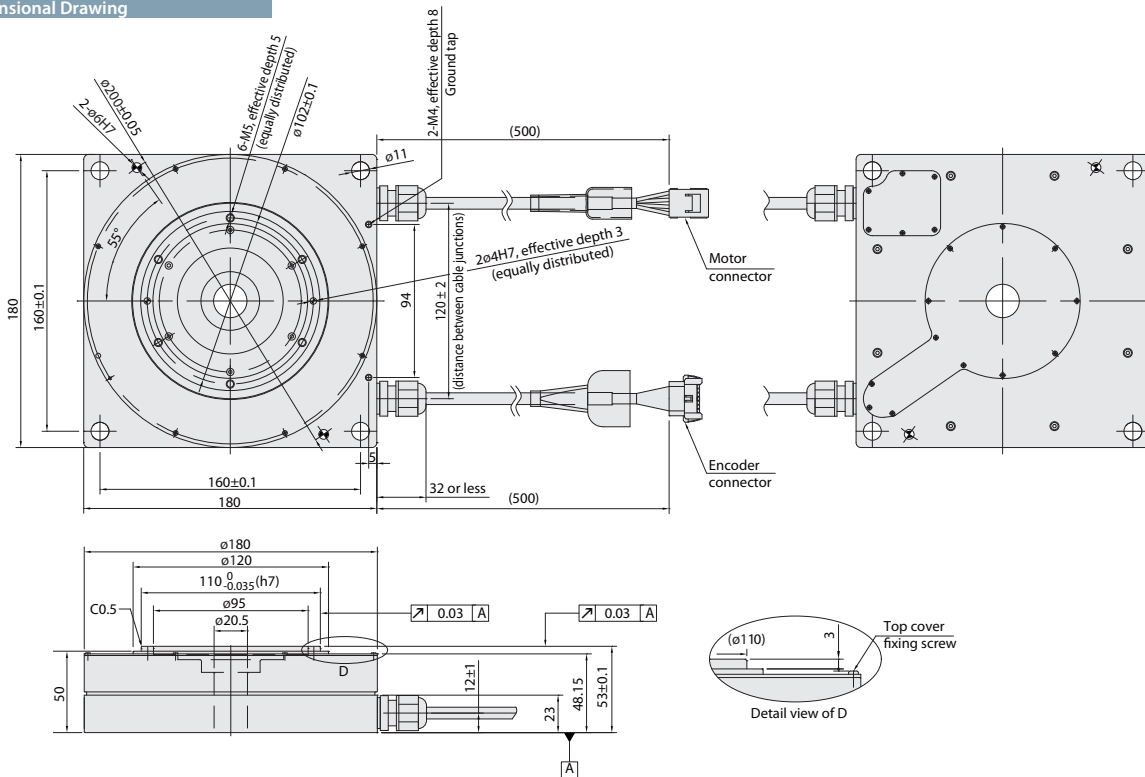

Applicable Controller Specification

Applicable controllers	Max. number of controlled axes	Operating method	Power supply voltage
SCON-CA	1-axis	Positioner	200VAC Single-phase
XSEL-P/Q/R/S	8-axes	Program	200VAC Three-phase



(Note 1) The maximum speed may not be reached if the moving distance is short.
 (Note 2) Assuming that the actuator is operated 24 hours a day at the rated rpm and smooth operation without shock, the actuator will reach its life in five years based on this load.
 (Note 3) The maximum cable length is 30 m. Specify a desired length in meters. (Example: X08 = 8m)

Controller Model Numbers

The controller may be selected from the two models described below.

Model Number of Positioner Single-axis Type <SCON-CA>

* Because the driver for the SCON-CA for DD motors is larger than the regular 200-watt type, the motor type will be 200S.

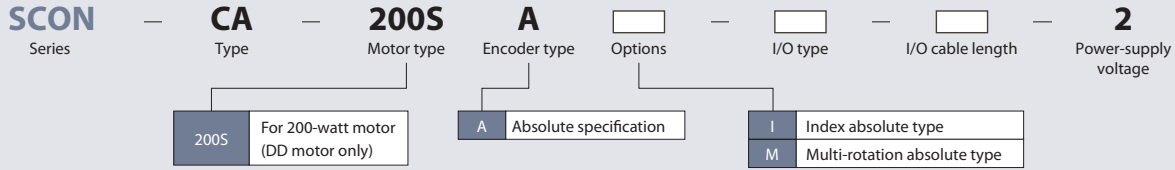

Model Number of Programmable Multi-axis Type <XSEL>

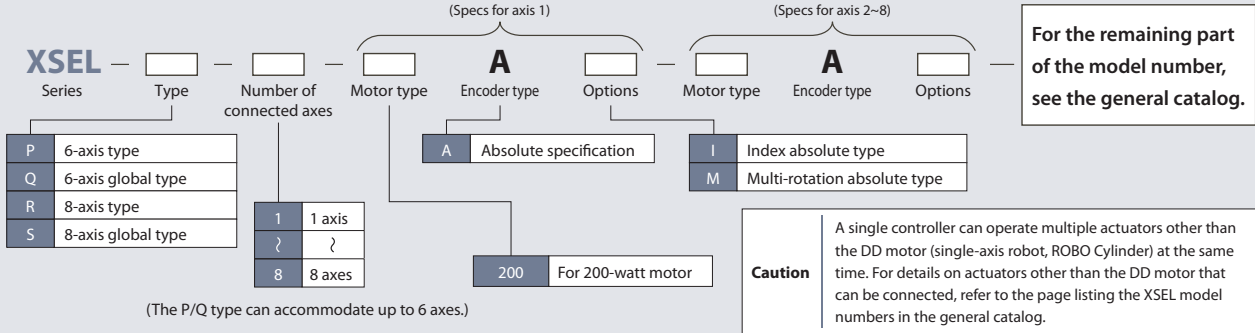

System Configuration

When the SCON controller is connected

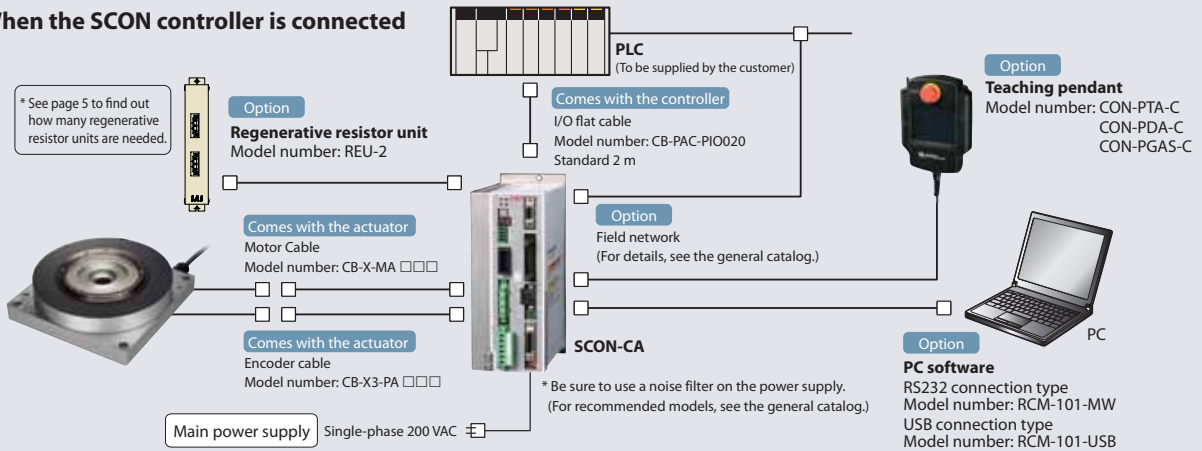

When the XSEL controller is connected

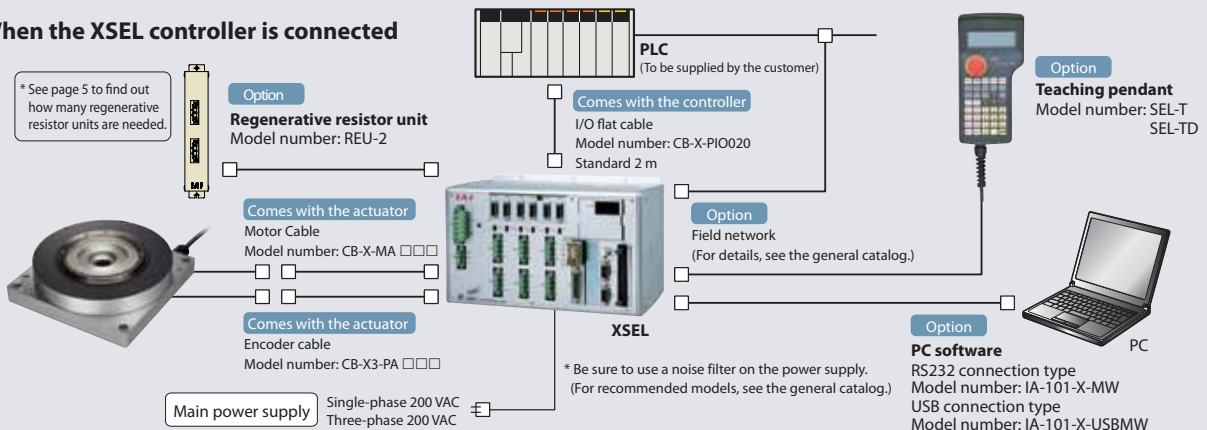

Notes

Installation

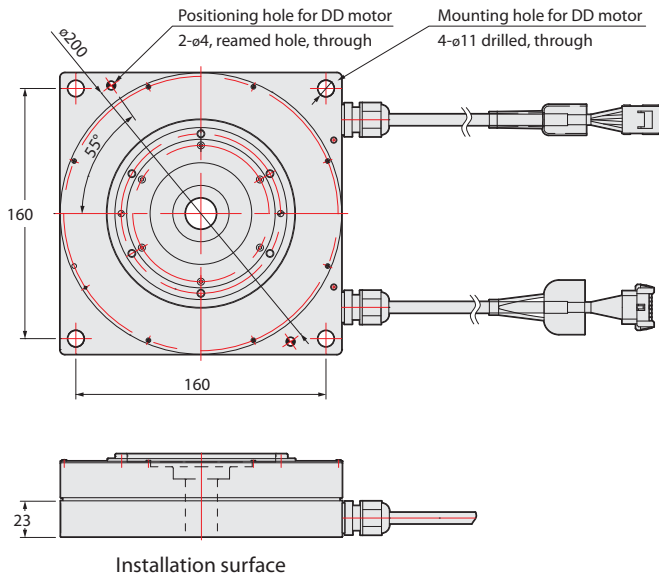

Installation Orientation

Do not install it in a vertical position or hung on the ceiling.

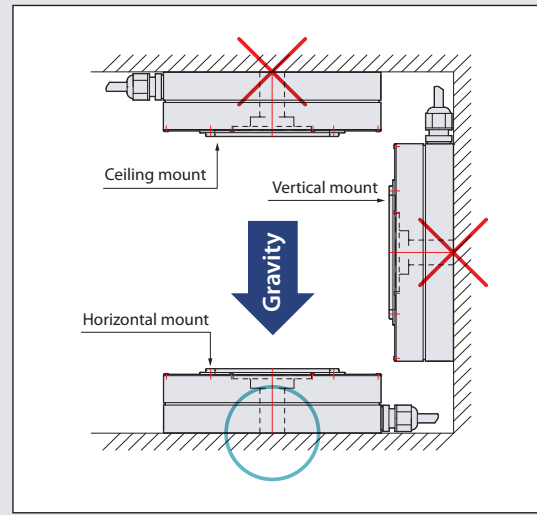

Operation Types

Two operation types can be selected to suit specific operating conditions. Check the features of the different types of DD motors and other notes before use.

Operation type	Index type		Multi-rotation absolute type	
	SCON-CA	XSEL	SCON-CA	XSEL
Controller type	SCON-CA	XSEL	SCON-CA	XSEL
Operation range	0~359.999°		Max. ±9999°	
Maximum travel per travel command	360°	180° (*1)	Within the above operation range	
Infinite rotation	Available (*2)		Not available	
Home return	Not required		Not required (*3)	
Absolute battery	Not required		Required	

(*1) When the XSEL index type travels more than 180° from the current position, it rotates in a direction that requires a shorter travel to reach the target position. Therefore, please note that the direction of rotation changes according to the current position and travel. If you want to specify the direction of travel, use the SCON-CA.

(*2) The index type can be rotated in a given direction infinitely, but it actually cannot continue to rotate in the same direction without stopping, like a regular motor does, because the maximum travel distance per command from the XSEL controller is 180°. If you want to allow the motor to rotate continuously, use the SCON-CA.

(*3) Home return is required for the multi-rotation absolute encoder during the initial setting and replacement of the absolute battery.

Controllers

- The output of the DD motor is 200 watts, but the outside dimensions of the SCON-CA controller are those of the 400-watt type. (For details on the outside dimensions of the SCON-CA, see the general catalog.)
- A regenerative resistor unit is required to operate a DD motor with the SCON-CA.
- When operating DD motor(s) with the XSEL controller, regenerative resistor units are required as shown below:

Number of DD motor(s)	1	2	3	4	5	6	7	8
Number of regenerative resistor units	1	2	3	4	5	6	7	8

- When connecting multiple DD motors to the XSEL controller, up to 1,600 watts worth of motors can be connected, assuming that a three-phase motor is 200 watts and a single-phase motor is 600 watts.
- Please note that, when the DD motor is operated with the SCON-CA, the motor cannot be connected to the ROBO Cylinder gateway function of the XSEL controller.

Conditions for Selection

The following should be checked to determine whether the DD motor can be used to suit the specific conditions required by the customer:

1 Check Load Conditions

The customer should confirm that the following three points under actual use do not exceed their maximum allowable levels as specified for the DD motor.

[1] Thrust load	Is the total load of device(s) mounted on the actuator no more than 3,400 N ?
[2] Load moment applied	Is the total load moment of device(s) mounted on the actuator no more than 80 N·m ?
[3] Load inertia	Is the load inertia of device(s) mounted on the actuator no more than 0.6 kg·m² ?

To calculate the load conditions, calculate the load inertia of device(s) mounted on the actuator and check the details with the DD motor selection software. The equations used to calculate the load inertia of typical shapes are shown below for reference purposes.

Download the DD motor selection software from: <http://www.iai-robot.co.jp/download/index.html>
 *** The English version software coming soon ***

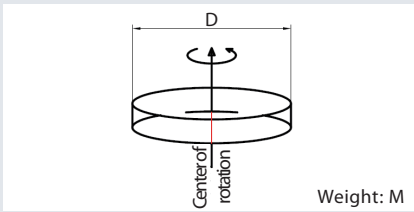
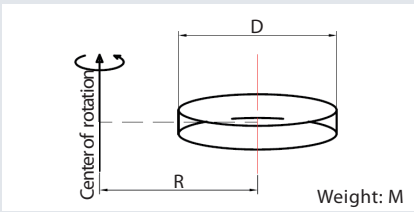
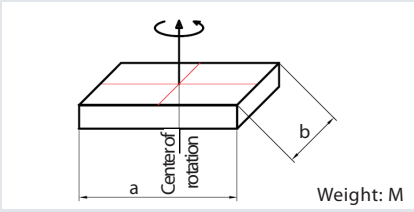
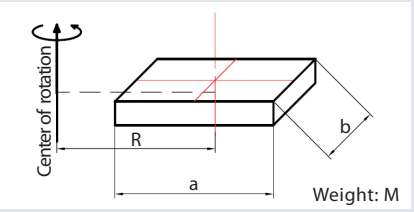
$J = 1/8 \times M \times D^2$  Weight: M	$J = M \times R^2 + 1/8 \times M \times D^2$  Weight: M
$J = 1/12 \times M \times (a^2 + b^2)$  Weight: M	$J = M \times R^2 + 1/12 \times M \times (a^2 + b^2)$  Weight: M

2 Check Operating Conditions

Check the distance, speed, acceleration, deceleration, stop time and other conditions in actual operation against the DD motor specifications to determine whether the DD motor can be used under the applicable operating conditions.

To calculate operating conditions, use the DD motor selection software.

Download the DD motor selection software from: <http://www.iai-robot.co.jp/download/index.html>
 *** The English version software coming soon ***

3 Maximum Acceleration/Deceleration Rate and Travel Time Guide

The maximum acceleration/deceleration rate is determined by the load inertia. See the table below to check the maximum acceleration/deceleration rate. The travel time data is also provided as a guide in the table below. **The data in the table is only intended as a guide, so the travel time is not guaranteed.*

Load inertia lower limit [kg·m²]	0	0.005	0.01	0.02	0.03	0.04	0.05	0.06	0.07	0.08	0.09	0.1	0.2	0.3	0.4	0.5
Load inertia upper limit [kg·m²]	0.005	0.01	0.02	0.03	0.04	0.05	0.06	0.07	0.08	0.09	0.1	0.2	0.3	0.4	0.5	0.6
45° travel time [sec.]	0.09	0.10	0.11	0.12	0.13	0.14	0.15	0.17	0.19	0.21	0.23	0.39	0.62	0.70	0.87	1.11
90° travel time [sec.]	0.12	0.12	0.14	0.16	0.17	0.18	0.20	0.22	0.24	0.26	0.29	0.48	0.73	0.83	1.02	1.23
180° travel time [sec.]	0.17	0.17	0.19	0.21	0.23	0.24	0.27	0.29	0.32	0.35	0.37	0.60	0.89	1.01	1.22	1.42
270° travel time [sec.]	0.22	0.22	0.24	0.26	0.27	0.29	0.32	0.35	0.38	0.41	0.44	0.69	1.00	1.14	1.36	1.68

(Note) The time listed in the above table is the duration from the reception of a travel command till convergence within the positioning band of 0.028 degrees (approximately 100 arcseconds).