

Electromagnetic Friction Clutches & Brakes

Shaft Mounted Clutch Couplings – Type SO



SO SERIES POWER-ON CLUTCH COUPLINGS

Shaft Mounted Clutch Couplings – Type SO

SO series power-on clutch couplings are used to couple two in-line shafts. The armature hub assembly is mounted to the load shaft, and the rotor assembly is mounted on the input shaft. The field assembly is mounted on the input shaft and retained by a loose-fitting pin or bracket through the anti-rotation tab.

Customer Shall Maintain:

A loose-fitting pin through the anti-rotation tab to prevent preloading the bearings; concentricity between the shafts within .005 inch (.127 mm) T.I.R.; initial air gap setting of .005-.020 inches (.127-.508 mm).

Model S008 through S026

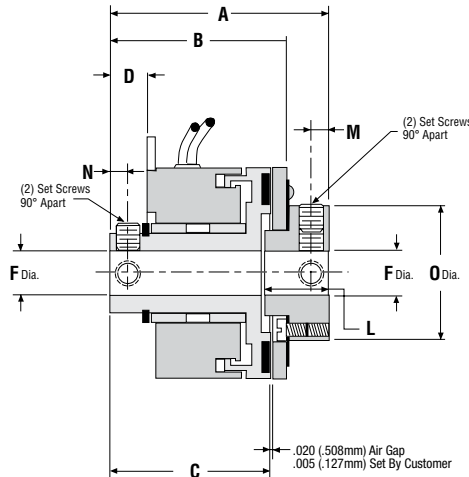
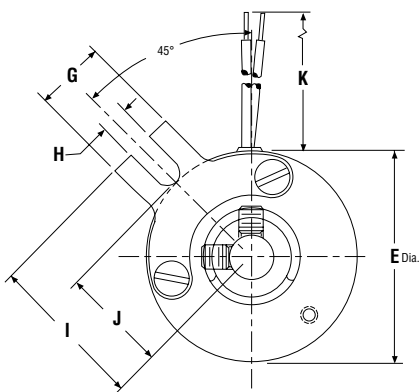

Model S030 and S042

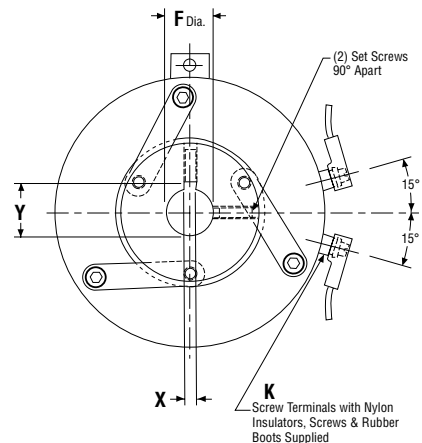
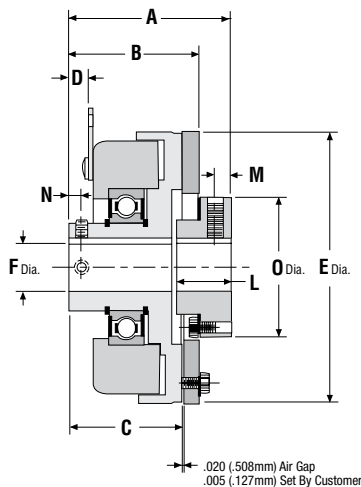
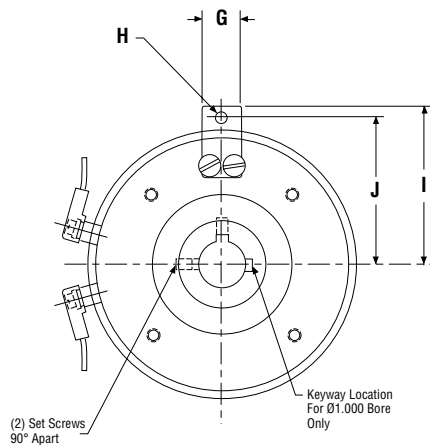

Electromagnetic Friction Clutches & Brakes

Shaft Mounted Clutch Couplings – Type SO Imperial

Mechanical

MODEL NO.	STATIC TORQUE LB. - IN.	INERTIA LB. - IN. ²		WEIGHT OZ.
		ROTOR	ARM & HUB	
S008	2.5	.002	.0011	2
S011	6	.0058	.0024	3.2
S015	10	.060	.026	3.8
S017	15	.061	.031	11
S019	25	.082	.042	12
S022	50	.215	.070	20
S026	80	.362	.320	28
S030	125	.610	.561	45
S042	250	2.50	2.30	80

Electrical

MODEL NO.	90 VDC		24 VDC		12 VDC	
	AMPS	OHMS	AMPS	OHMS	AMPS	OHMS
S008	.046	1977	.117	205	.246	48.8
S011	.047	1930	.198	121	.447	26.8
S015	.042	2150	.183	132	.380	31.6
S017	.066	1369	.289	83	.561	21.4
S019	.074	1213	.322	74.4	.574	20.9
S022	.079	1140	.322	74.6	.628	19.1
S026	.092	980	.374	64.2	.760	15.8
S030	.091	988	.378	65.3	.729	16.4
S042	.124	722	.468	51.2	.934	12.84

Lead wire is UL recognized style 1213, 1015 or 1430, 22 gage.

Insulation is .050 O.D. on 08, 11, 15 units; .064 or .095 O.D. on all other units.

Dimensions

MODEL NO.	A MAX.	B NOM.	C NOM.	D NOM.	E MAX.	F NOM.	G MAX.	H MIN.	I NOM.	J NOM.	K NOM.	ROTOR KEYWAY		L NOM.	M ± .500	N NOM.	O NOM.	
												BORE	KEYWAY					
													X					Y
S008	1.059	.875	.763	.191	.903	1/8 3/15 1/4	.305	.094	.625	.445	12.00	N.A.	SET SCREWS ONLY		.237	.070	.080	.500
S011	1.168	.933	.777	.147	1.160	3/16 1/4 5/16	.380	.122	.875	.585	12.00	N.A.	SET SCREWS ONLY		.307	.093	2.032	.687
S015	1.575	1.255	1.075	.275	1.500	1/4 5/16 3/8	.520	.180	1.120	.750	12.00	N.A.	SET SCREWS ONLY		.475	.125	.125	.965
S017	1.605	1.311	1.060	.270	1.780	1/4 5/16 3/8	.505	.184	1.325	.975	12.00	1/4 5/16 3/8	SET SCREWS ONLY		.460	.115	.125	1.190
S019	1.609	1.314	1.060	.270	2.000	5/16 3/8 1/2	.505	.184	1.325	.975	12.00	5/16 3/8 1/2	.0625 – .0655 .094 – .097 .125 – .128	.347 – .352 .417 – .427 .560 – .567	.455	.115	.125	1.190
S022	1.989	1.578	1.423	.281	2.260	3/8 1/2	.442	.170	1.515	1.160	18.00	3/8 1/2	.094 – .097 .125 – .128	.417 – .427 .560 – .567	.510	.115	.117	1.005
S026	2.115	1.754	1.444	.277	2.645	3/8 1/2 5/8	.510	.190	1.750	1.465	18.00	3/8 1/2 5/8	.094 – .097 .125 – .128 .1885 – .1905	.417 – .427 .560 – .567 .709 – .716	.610	.150	.154	1.440
S030	2.151	1.815	1.403	.265	3.268	1/2 5/8 3/4	.442	.170	2.050	1.695	SCREW TERMINALS	1/2 5/8 3/4	.125 – .128 .1885 – .1905 .1885 – .1905	.560 – .567 .709 – .716 .836 – .844	.680	.150	.135	1.825
S042	2.570	2.050	1.625	.320	4.270	1/2 5/8 3/4 7/8 1	.645	.190	2.500	2.312	SCREW TERMINALS	1/2 5/8 3/4 7/8 1	.125 – .128 .1885 – .1905 .1885 – .1905 .1885 – .1905 .251 – .253	.560 – .567 .709 – .716 .836 – .844 .962 – .970 1.113 – 1.121	.890	.250	.187	2.195

Notes:

- 30 and 42 units have a single ball bearing between the field and rotor.
- 08 units have set screws 120° apart.
- 08 and 19 units have retaining collar.

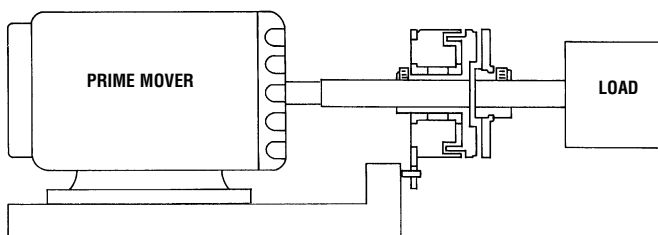

See page 4 for Ordering Information

Electromagnetic Friction Clutches & Brakes

Shaft Mounted Clutch Couplings – Type S0 Metric

Mechanical

MODEL NO.	STATIC TORQUE N-m	INERTIA kg - cm ²		WEIGHT kg
		ROTOR	ARM & HUB	
S008	0.28	0.006	0.003	.06
S011	0.68	0.017	0.007	.09
S015	1.13	0.176	0.076	.11
S017	1.70	0.179	0.091	.31
S019	2.83	0.240	0.123	.34
S022	5.65	0.629	0.205	.57
S026	9.04	1.059	0.936	.79
S030	14.12	1.785	1.642	1.28
S042	28.24	7.316	6.731	2.27

Electrical

MODEL NO.	90 VDC		24 VDC		12 VDC	
	AMPS	OHMS	AMPS	OHMS	AMPS	OHMS
S008	.046	1977	.117	205	.246	48.8
S011	.047	1930	.198	121	.447	26.8
S015	.042	2150	.183	132	.380	31.6
S017	.066	1369	.289	83	.561	21.4
S019	.074	1213	.322	74.4	.574	20.9
S022	.079	1140	.322	74.6	.628	19.1
S026	.092	980	.374	64.2	.760	15.8
S030	.091	988	.378	65.3	.729	16.4
S042	.124	722	.468	51.2	.934	12.84

Lead wire is UL recognized style 1213, 1015 or 1430, 22 gage.

Insulation is 1.27 mm O.D. on 08, 11, 15 units; .163 mm or 2.41 mm O.D. on all other units.

Dimensions

MODEL NO.	A MAX.	B NOM.	C NOM.	D NOM.	E MAX.	F NOM.	G MAX.	H MIN.	I NOM.	J NOM.	K ± 12.7	ROTOR KEYWAY		L NOM.	M ±12.7	N NOM.	O NOM.	
												BORE	KEYWAY					
													X					Y
S008	26.899	22.225	19.380	4.851	22.936	5H9	7.747	2.388	15.875	11.303	304.800	N.A.	SET SCREWS ONLY	6.020	1.778	2.032	12.700	
S011	29.667	23.698	19.736	3.734	29.464	6H9 8H9	9.652	3.099	22.225	14.859	304.800	N.A.	SET SCREWS ONLY	7.798	2.362	51.613	17.450	
S015	40.005	31.877	27.305	6.985	38.100	8H9 10H9	13.208	4.572	28.448	19.050	304.800	N.A.	SET SCREWS ONLY	12.065	3.175	3.175	24.511	
S017	40.767	33.299	26.924	6.858	45.212	8H9 10H9	12.827	4.674	33.655	24.765	304.800	8H9 10H9	1.988-2.060 2.988-3.060	9.00-9.10 11.40-11.50	11.684	2.921	3.175	30.226
S019	40.869	33.376	26.924	6.858	50.800	10H9	12.827	4.674	33.655	24.765	304.800	10H9	2.988-3.060	11.40-11.50	11.557	2.921	3.175	30.226
S022	50.521	40.081	32.334	7.137	57.404	10H9	11.227	4.318	38.481	29.464	457.200	10H9	2.988-3.060	11.40-11.50	12.954	2.921	2.972	25.527
S026	53.721	44.552	36.678	7.036	67.183	10H9 15H9	12.954	4.826	44.950	37.211	457.200	10H9 15H9	2.988-3.060 4.985-5.078	11.40-11.50 17.30-17.40	15.494	3.810	3.912	36.576
S030	54.635	46.101	35.636	6.731	83.007	15H9	11.227	4.318	52.070	43.053	SCREW TERMINALS	15H9	4.985-5.078	17.30-17.40	17.272	3.810	3.429	46.355
S042	65.278	52.070	41.275	8.128	108.458	17H9 20H9 25H9	16.383	4.826	63.500	58.725	SCREW TERMINALS	17H9 20H9 25H9	4.985-5.078 5.985-6.078 7.982-8.098	19.30-19.40 22.80-22.90 28.30-28.50	22.606	6.350	4.750	55.753

Notes:

- 30 and 42 units have a single ball bearing between the field and rotor.
- 08 units have set screws 120° apart.
- 08 and 19 units have retaining collar.

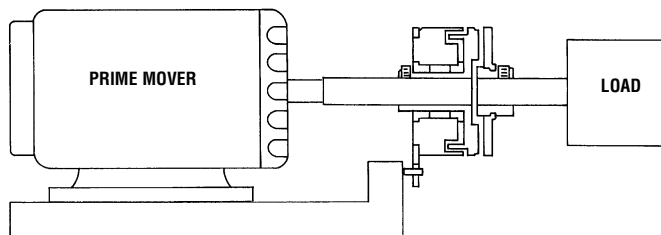

See page 4 for Ordering Information