

Electromagnetic Friction Clutches & Brakes

Flange Mounted Clutch Couplings – Type FO

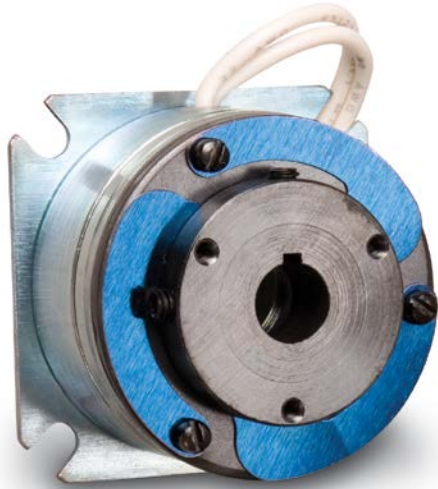

FO SERIES POWER-ON CLUTCH COUPLINGS

Flange Mounted Clutch Couplings – Type FO

FO series power-on clutch couplings are used to couple two in-line shafts. The armature hub assembly is mounted to the load shaft, and the rotor assembly is mounted on the input shaft. The field assembly is mounted to a bulkhead that is perpendicular to the shaft.

Customer Shall Maintain:

The perpendicularity of the mounting surface with respect to the shaft not to exceed .005 inch (.127mm) T.I.R. at a diameter equal to the bolt circle; initial air gap setting of .005-.020 inches (.127 - .508mm); concentricity between the clutch mounting pilot diameter and the shaft not to exceed .004 inch (.102mm) T.I.R.

Model F008 through F026

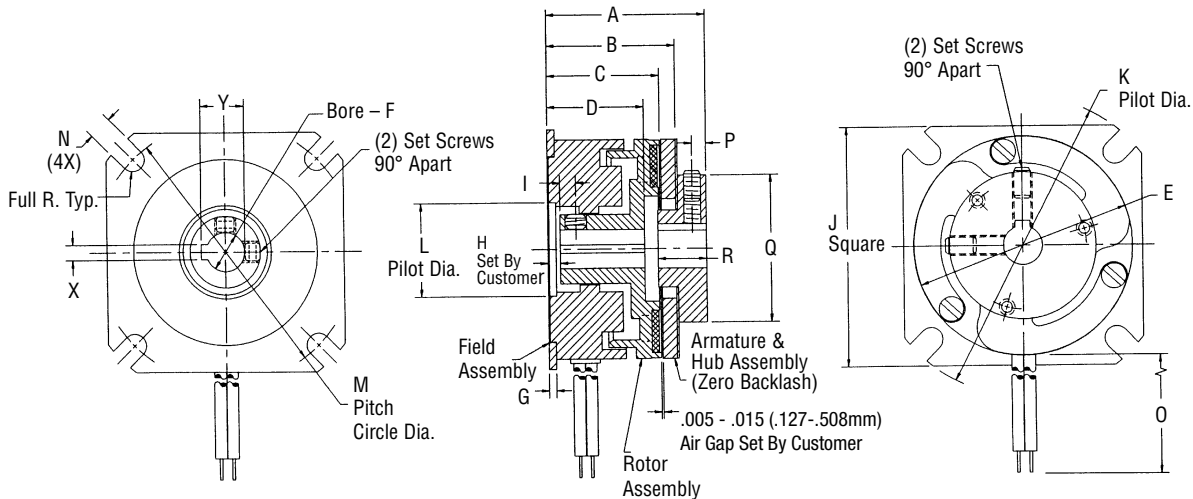

Model F030 and F042

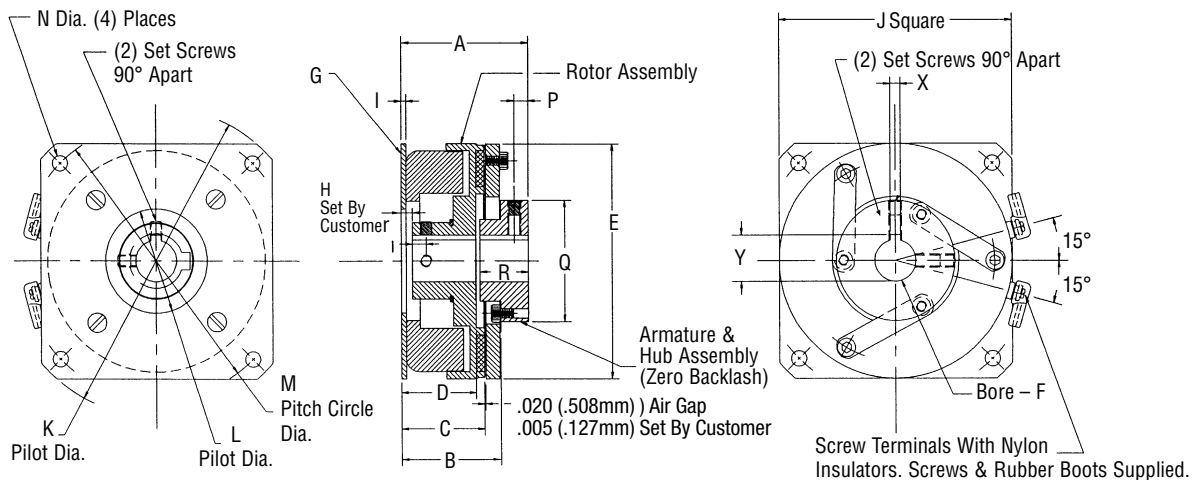

Electromagnetic Friction Clutches & Brakes

Flange Mounted Clutch Couplings – Type FO Imperial

Mechanical

MODEL NO.	STATIC TORQUE LB. - IN.	INERTIA LB. - IN. ²		WEIGHT OZ.
		ROTOR	ARM & HUB	
F008	2.5	.0019	.0011	2
F011	6	.005	.0024	3.2
F015	10	.0054	.026	3.8
F017	15	.059	.031	11
F019	25	.080	.042	12
F022	50	.210	.070	20
F026	80	.451	.320	28
F030	125	.610	.561	40
F042	250	2.50	2.30	75

Electrical

MODEL NO.	90 VDC		24 VDC		12 VDC	
	AMPS	OHMS	AMPS	OHMS	AMPS	OHMS
F008	.046	1977	.117	205	.246	48.8
F011	.047	1930	.198	121	.447	26.8
F015	.042	2150	.183	132	.380	31.6
F017	.066	1369	.289	83	.561	21.4
F019	.074	1212	.322	74.4	.574	20.9
F022	.079	1140	.322	74.6	.628	19.1
F026	.088	1024	.358	67.1	.667	18.0
F030	.091	988	.378	65.3	.729	16.5
F042	.124	722	.468	51.2	.934	12.84

Lead wire is UL recognized style 1213, 1015 or 1430, 22 gage.
Insulation is .050 O.D. on 08, 11, 15 units; .064 or .095 O.D. on all other units.

Dimensions

MODEL NO.	A MAX.	B NOM.	C NOM.	D NOM.	E MAX.	F NOM.	G MAX.	H ±.005	I ±.005	J MAX.	K ±.001	L ±.001	M NOM.	N MIN.	O ±.500	ROTOR KEYWAY		P NOM.	Q MAX.	R MAX.	
																BORE	KEYWAY				
																	X				Y
F008	.882	.693	.641	.582	.905	1/8 3/16 1/4	.034	.020	.188	.980	1.1995	N.A.	1.030	.094	12.00	N.A.	ONE ROLL PIN PILOT HOLE	.070	.500	.237	
F011	1.012	.772	.691	.616	1.160	3/16 1/4 5/16	.048	.020	.188	1.230	1.498	N.A.	1.312	.123	12.00	N.A.	ONE ROLL PIN PILOT HOLE	.093	.687	.307	
F015	1.302	.972	.865	.800	1.500	1/4 5/16 3/8	.063	.100	.130	1.567	1.999	N.A.	1.750	.156	12.00	N.A.	ONE ROLL PIN PILOT HOLE	.125	.965	.475	
F017	1.328	1.051	.925	.800	1.780	1/4 5/16 3/8	.064	.100	.130	1.943	2.436	.751	2.125	.186	12.00	1/4 5/16 3/8	.0625 - .0655 .0625 - .0655 .094 - .097	.285 - .290 .347 - .352 .417 - .427	.115	1.19	.45
F019	1.330	1.029	.901	.781	2.000	5/16 3/8 1/2	.062	.100	.130	1.943	2.436	.751	2.125	.186	12.00	5/16 3/8 1/2	.0625 - .0655 .094 - .097 ROLL PIN HOLE	.347 - .352 .417 - .427	.115	1.19	.455
F022	1.757	1.325	1.173	1.023	2.260	3/8 1/2	.096	.100	.188	2.322	2.873	1.001	2.500	.160	18.00	3/8 1/2	.094 - .097 .125 - .128	.417 - .427 .560 - .567	.115	1.005	.510
F026	1.813	1.460	1.300	1.150	2.645	3/8 1/2 5/8	.080	.375	.172	2.630	3.499	1.062	3.125	.182	18.00	3/8 1/2 5/8	.094 - .097 .125 - .128 .1885 - .1905	.417 - .427 .560 - .567 .709 - .716	.150	1.44	.610
F030	1.900	1.580	1.310	1.160	3.268	1/2 5/8 3/4	.097	.147	.093	3.200	4.186	1.751	3.750	.182	SCREW TERMINALS	1/2 5/8 3/4	.125 - .128 .1885 - .1905 .1885 - .1905	.560 - .567 .709 - .716 .836 - .844	.150	1.825	.680
F042	2.280	1.760	1.490	1.490	4.270	1/2 5/8 3/4 7/8 1	.097	.190	.250	4.270	5.624	1.875	5.000	.276	SCREW TERMINALS	1/2 5/8 3/4 7/8 1	.125 - .128 .1885 - .1905 .1885 - .1905 .1885 - .1905 .251 - .253	.560 - .567 .709 - .716 .836 - .844 .962 - .970 1.113 - 1.121	.250	2.195	.890

Notes:

- 08, 11 and 15 units have one roll pin pilot hole in rotor – no set screws.

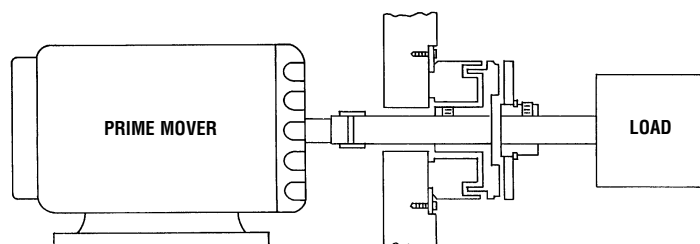

See page 4 for Ordering Information

Electromagnetic Friction Clutches & Brakes

Flange Mounted Clutch Couplings – Type FO Metric

Mechanical

MODEL NO.	STATIC TORQUE N-m	INERTIA kg-cm ²		WEIGHT kg
		ROTOR	ARM & HUB	
F008	.28	.006	.003	.06
F011	.68	.015	.007	.09
F015	1.13	.016	.076	.11
F017	1.70	.173	.091	.31
F019	2.83	.234	.123	.34
F022	5.65	.615	.205	.57
F026	9.04	1.320	.936	.79
F030	14.12	1.785	1.642	1.13
F042	28.24	7.316	6.731	2.13

Electrical

MODEL NO.	90 VDC		24 VDC		12 VDC	
	AMPS	OHMS	AMPS	OHMS	AMPS	OHMS
F008	.046	1977	.117	205	.246	48.8
F011	.047	1930	.198	121	.447	26.8
F015	.042	2150	.183	132	.380	31.6
F017	.066	1369	.289	83	.561	21.4
F019	.074	1212	.322	74.4	.574	20.9
F022	.079	1140	.322	74.6	.628	19.1
F026	.088	1024	.358	67.1	.667	18.0
F030	.091	988	.378	65.3	.729	16.5
F042	.124	722	.468	51.2	.934	12.84

Lead wire is UL recognized style 1213, 1015 or 1430, 22 gage.
 Insulation is 1.27 mm O.D. on 08, 11, 15 units; .163 mm or 2.41 mm O.D. on all other units.

Dimensions

MODEL NO.	A MAX.	B NOM.	C NOM.	D NOM.	E MAX.	F NOM.	G MAX.	H ±.127	I ±.127	J MAX.	K ±.025	L ±.025	M NOM.	N MIN.	O ±12.7	ROTOR KEYWAY		P NOM.	Q MAX.	R MAX.	
																BORE	KEYWAY				
																	X				Y
F008	22.403	17.602	16.281	14.783	22.987	5H9	0.864	0.508	4.755	24.892	30.467	N.A.	26.162	2.388	304.800	N.A.	ONE ROLL PIN HOLE	1.778	12.700	6.020	
F011	25.705	19.609	17.551	15.646	29.469	6H9 8H9	1.219	0.508	4.775	31.242	38.049	N.A.	33.325	3.124	304.800	N.A.	ONE ROLL PIN HOLE	2.362	17.450	7.798	
F015	33.071	24.689	21.971	20.320	38.100	8H9 10H9	1.600	2.540	3.302	39.802	50.775	N.A.	44.450	3.962	304.800	N.A.	ONE ROLL PIN HOLE	3.175	24.511	12.065	
F017	34.239	26.695	23.495	20.320	45.212	8H	1.626	2.540	3.302	49.352	61.874	19.050	53.975	4.724	304.800	8H9	1.988-2.060 9.00-9.10	2.921	30.226	11.43	
F019	33.782	26.137	22.885	19.837	50.800	10H9	1.575	2.540	3.302	49.352	61.874	19.050	53.975	4.724	304.800	10H9	2.988-3.060 11.40-11.50	2.921	30.226	11.557	
F022	44.628	33.655	29.794	25.984	57.404	10H9	2.438	2.540	4.775	58.979	72.974	25.425	63.500	4.064	457.200	10H9	2.988-3.060 11.40-11.50	2.921	25.527	12.954	
F026	46.050	37.084	33.020	29.210	67.183	10H9 15H9	1.626	9.525	4.639	66.802	88.875	26.975	79.375	4.623	457.700	10H9 15H9	2.988-3.060 4.985-5.078 11.40-11.50 17.30-17.40	3.810	36.576	15.494	
F030	48.260	40.132	33.274	29.464	83.007	15H9 17H9	2.464	3.734	7.874	81.280	106.324	44.475	95.250	4.623	SCREW TERMINALS	15H9 17H9	4.985-5.078 4.985-5.078 17.30-17.40 19.30-19.40	3.810	46.355	17.272	
F042	57.912	44.704	37.846	34.163	108.458	17H9 20H9 25H9	2.464	4.826	6.350	108.077	142.850	47.625	127.000	7.010	SCREW TERMINALS	17H9 20H9 25H9	4.985-5.078 5.985-6.078 7.982-8.098 19.30-19.40 22.80-22.90 28.30-28.50	6.350	55.753	22.606	

Notes:

- 08, 11 and 15 units have one roll pin pilot hole in rotor – no set screws.

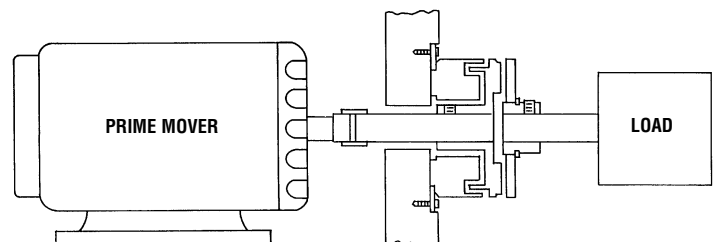

See page 4 for Ordering Information