

Clutch Couplings and Clutches

Zero Air Gap Accessory Kit

Used With

- 305 through 310

The purpose of this kit is to hold the armature plate in contact with the friction face to reduce pull-in time. It is recommended where the engagement time is critical; usually high cycle rate applications with the D2950 control. Also use this kit when a slow start or stop is required with the D2750 control. Since the friction surfaces are always in contact a rubbing noise is created. The design of your machine may increase or decrease this noise.

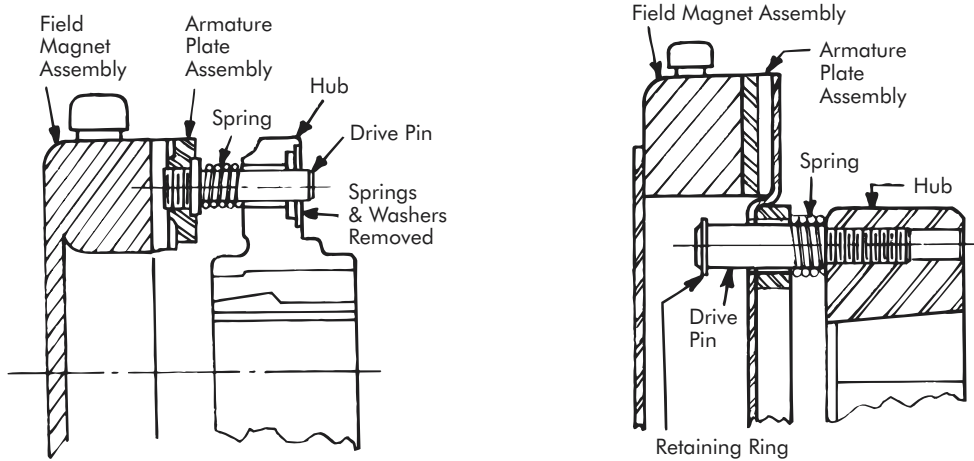

Model No.	Accessory Group
305	326303
308 - 315	326240