

Wrap Spring Clutches

Spring Clutch

Product Functions: Overrunning  - Start-Coast  - Single Revolution 

Models

- SC-2
- SC-4
- SC-5
- SC-6
- SC-8

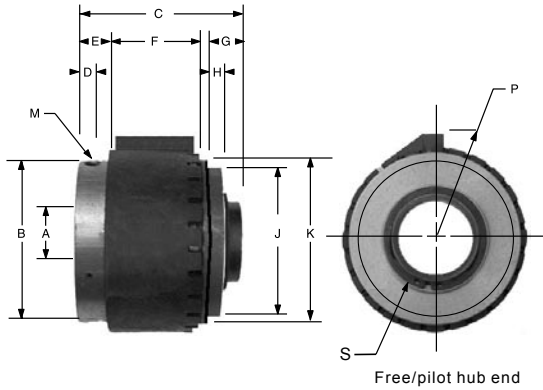

SC-2, SC-4 and SC-5

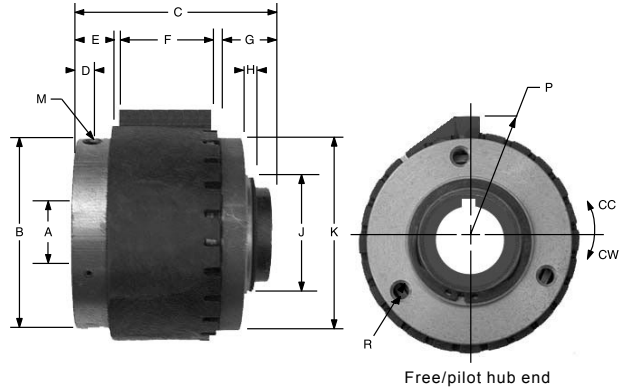

SC-6 and SC-8

Standard Mounting Dimensions (inches)

Model	A ¹	Keyway	B	C	D	E	F	G	H	J	K	M ²	P	R			S ⁴	Torque in. lbs.	Max. RPM
														Dia.	No. of Holes	Bolt Circle			
SC-2	.250	None	.94	1.25	.16	.34	.49	.41	.24	.8775/.8765	.94	8-32	.57	—	—	—	.59	25	1800
SC-4	.375	None	1.25	1.38	.14	.28	.67	.35	.25	1.1275/1.1265	1.25	.125	.72	—	—	—	.65	125	1200
SC-5	.500	None	1.56	1.88	.14	.38	1.00	.35	.25	1.503/1.502	1.56	.188	.85	—	—	—	.80	250	750
SC-6	.750	3/16x3/32	2.44	2.31	.28	.50	.866	.41	.125	1.562/1.559	2.437	1/4-20	1.50	1/4-20	3	2.062	—	500	500
	1.000	None	2.44	2.31	.28	.50	.866	.41	.125	1.562/1.559	2.437	1/4-20	1.50	1/4-20	3	2.062	—	500	500
SC-8	1.000	1/4x1/8	4.00	3.50	.30	.60	1.98	.88	.18	2.374/2.372	4.025	3/16-16	2.00	5/16-18	6	3.375	—	2500	300
	1.250 ³	5/16x5/32	4.00	3.50	.30	.60	1.98	.88	.18	2.374/2.372	4.025	3/16-16	2.00	5/16-18	6	3.375	—	2500	300
	1.375	5/16x5/32	4.00	3.50	.30	.60	1.98	.88	.18	2.374/2.372	4.025	3/16-16	2.00	5/16-18	6	3.375	—	2500	300
	1.500 ³	3/8x1/8	4.00	3.50	.30	.60	1.98	.88	.18	2.374/2.372	4.025	3/16-16	2.00	5/16-18	6	3.375	—	2500	300

NOTE: Rotation is determined by looking at the free/pilot hub end.

¹ Tolerance is +.0005 / +.0030

² Pin diameter shown on sizes SC-4 and SC-5.

³ SC-8 Standard bores.

⁴ Retaining ring clearance diameter.

How to Order:

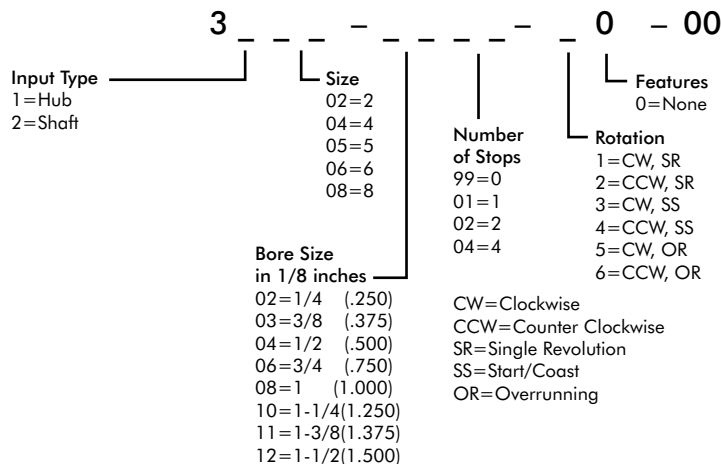

SR units (Brake Torque is 10% of Maximum Torque).

Example

SC-6 clutch, hub input, 3/4" bore, 2 stops, clockwise single revolution. Part No. 3106-0602-10-00.

Wrap Spring Clutches – Replacement Parts

SC Spring Clutch Replacement Parts

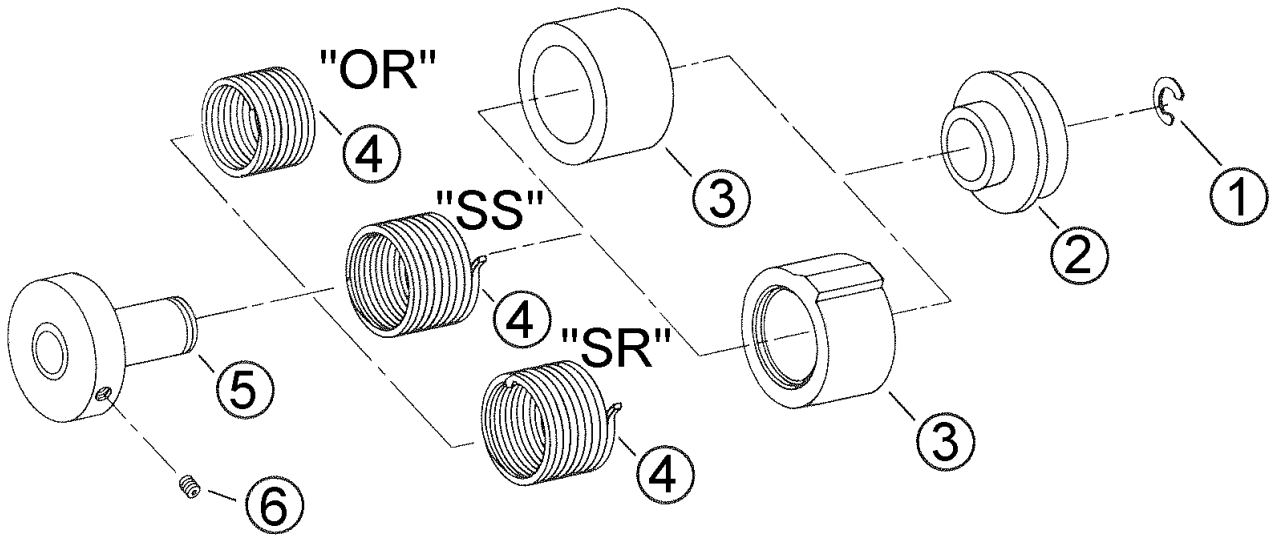

Item	Model SC-2 Part No.	Model SC-4 Part No.	Model SC-5 Part No.	Model SC-6 Part No.	Model SC-8 Part No.	Description
1	040-0310	101316	D748-1-0030	D748-1-0038	D748-1-0039	Retaining Ring
2	002-4218	102335-1	102347	D540-6-0009	D540-8-0014	Free / Pilot Hub
3	002-4236	103398	103393	D287-6-0001	100999	Overrunning Collar
	002-4317	102336-5	103392-5	D266-6-0301	100784-5	1 Stop Collar
	002-4319	102336-6	103392-6	D266-6-0302	100784-6	2 Stop Collar
	002-4320	102336-8	103392-8	D266-6-0304	100784-8	4 Stop Collar
4	002-2028	D808-4-0066	D808-5-0001	D808-6-0001	D808-8-0003	SR Drive Spring LH ¹
	002-2029	D808-4-0059	D808-5-0002	D808-6-0002	D808-8-0004	SR Drive Spring RH ²
	002-2024	D808-4-0066-1	D808-5-0001-1	D808-6-0007	D808-8-0003-1	SS Drive Spring LH ¹
	002-2025	D808-4-0059-1	D808-5-0002-1	D808-6-0008	D808-8-0004-1	SS Drive Spring RH ²
	002-2026	D808-4-0066-2	D808-5-0001-2	D808-6-0009	D808-8-0003-2	OR Drive Spring LH ¹
	002-2027	D808-4-0059-2	D808-5-0002-2	D808-6-0010	D808-8-0004-2	OR Drive Spring RH ²
5	002-5409	103131	102494	-	-	Shaft Hub Assembly
	-	-	-	D824-6-0052	-	3/4 Bore Shaft Hub Assembly
	-	-	-	D824-6-0056	100996-4	1 Bore Shaft Hub Assembly
	-	-	-	-	100996-5	1-1/4 Bore Shaft Hub Ass'y
	-	-	-	-	100996-6	1-3/8 Bore Shaft Hub Ass'y
	-	-	-	-	100996-1	1-1/2 Bore Shaft Hub Ass'y
6	040-0432	-	-	100987	101001	Set Screw

¹ CW Hub Input / CCW Shaft Input

² CCW Hub Input / CW Shaft Input