

Wrap Spring Clutches

DCB-5 SUPER Dimensions

Product Function: Start-Stop 

Specifications

Maximum Speed:	750 RPM	Needle Bearing Input and Output Hubs with Roller Clutch AB and AOR
Static Torque:	250 in.-lb	Hardened Output Shaft
Max. Anti-override Torque:	125 in.-lb.	Hardened Wear Rings at Cross-Over Points
Max Anti-back Torque:	125 in.-lb.	Stainless Steel Actuator Face
Positioning Accuracy:	$\pm 1/2^\circ$	
Weight:	1.75 lbs.	

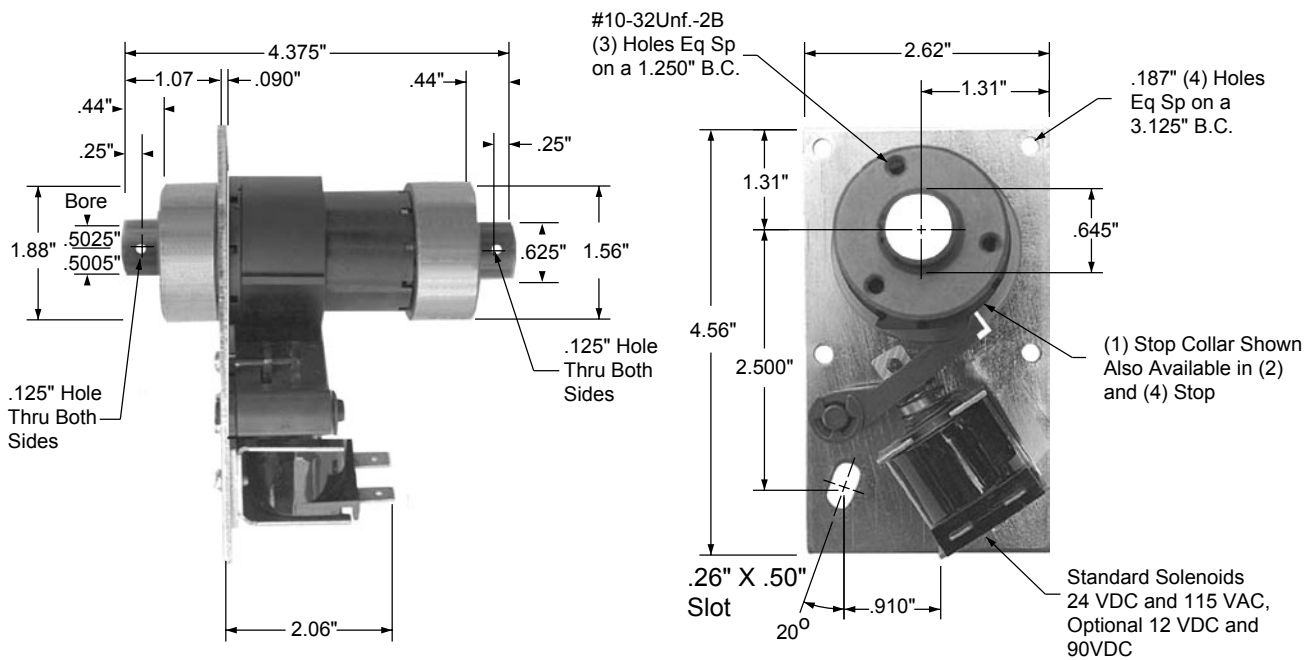

Unit Shown is CW Rotation, CCW is Available

DCB-5 SUPER Part Numbers

Part Number		Description			
CW Rotation	CCW Rotation	Model	Bore	Voltage	Stops
D325-17-004	D325-27-004	DCB5 SUPER	1/2"	115VAC	1
D325-17-005	D325-27-005	DCB5 SUPER	1/2"	115VAC	2
D325-17-006	D325-27-006	DCB5 SUPER	1/2"	115VAC	4
D325-17-001	D325-27-001	DCB5 SUPER	1/2"	24VDC	1
D325-17-002	D325-27-002	DCB5 SUPER	1/2"	24VDC	2
D325-17-003	D325-27-003	DCB5 SUPER	1/2"	24VDC	4

Sold & Serviced By:

 Toll Free Phone (877) SERV098
 Toll Free Fax (877) SERV099
www.electromate.com
sales@electromate.com

Wrap Spring Clutches – Replacement Parts

DCB-5 SUPER Replacement Parts

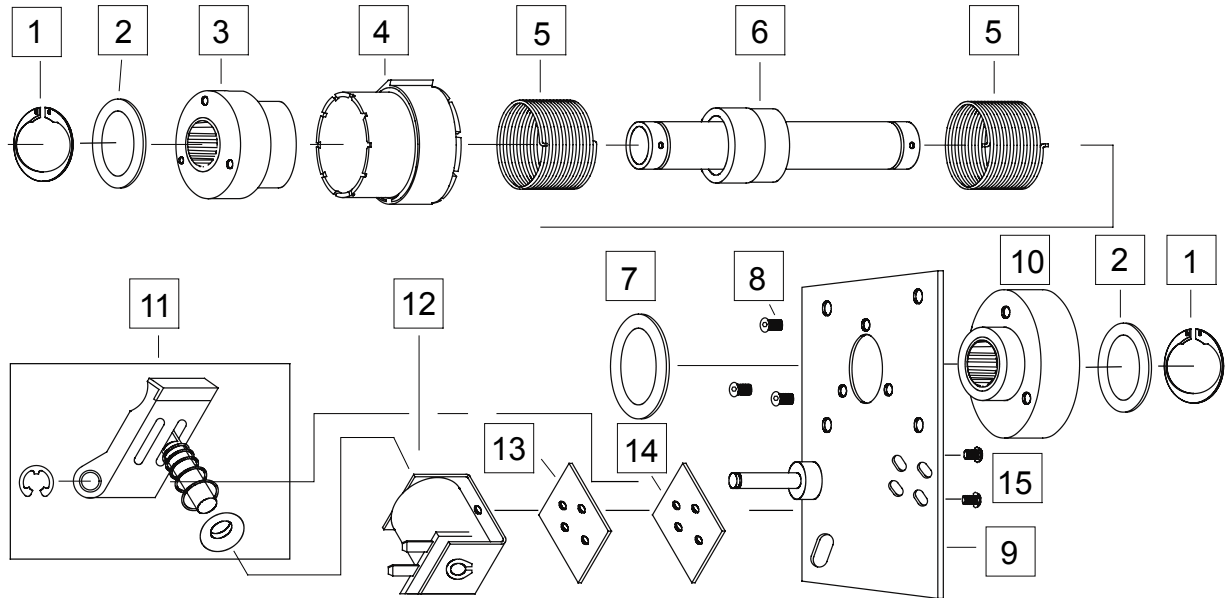

Item	Part No.	Rotation or Voltage	Description
1	D748-1-0030		(2) Retaining Ring
2	104702		(2) Thrust Washer
3	104698 104698-1	CW CCW	Input Hub with Anti-Overrun Bearing
4	D266-5-0101 D266-5-0102 D266-5-0104 D266-5-0201 D266-5-0202 D266-5-0204	CW CW CW CCW CCW CCW	1 Stop Collar 2 Stop Collar 4 Stop Collar 1 Stop Collar 2 Stop Collar 4 Stop Collar
5	D808-5-0001 D808-5-0002	CW CCW	(2) Drive or Brake Spring
6	104694		Output Assembly 1/2 Bore
7	104701		Thrust Washer
8	D797-1-0322		(3) 8-32 Flat Hd Socket Cap Screw
9	104690 104690-1	CW CCW	Plate Assembly
10	104700-1 104700	CW CCW	Brake Hub with Anti-Back Bearing
11	104935 104935-1	CW CCW	Actuator Assembly w/ Stainless Steel Tip
12	D275-1-0163 D275-1-0166 D275-1-0163 D275-1-0166	24 VDC 115 VAC 12 VDC 90 VDC	Coil Assembly
13	104687		Solenoid Spacer
14	104406		Solenoid Spacer
15	040-04270		(2) 6-32 Sems Machine Screw