

Model 310 Clutch-Brake Coupling Inside Mounted Per FC-310016

Model 310 Clutch-Brake Coupling Outside Mounted Per FC-310017

Technical Data

Static Torque	300 lb. ft.	
Maximum Speed	3000 RPM	
Coil Voltage	90 vdc	24 vdc
Rated Current584 amp	2.7 amp

MODEL 310—Torque at Various RPM Points

RPM	0	300	600	900	1200	1500	1800	2400	3000
Lb. Ft.	300	262	218	174	149	133	118	87	74

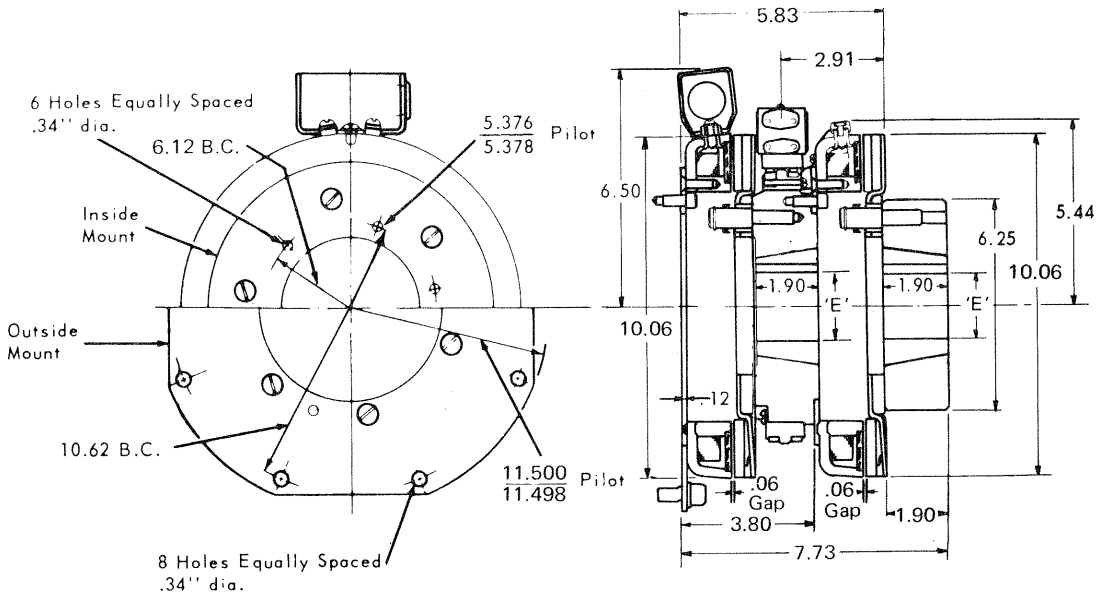

Customer Must Maintain:

1. Concentricity between shafts within .010 T.I.R.
2. Angular alignment of shafts within .010 T.I.R.
3. Composite of both within .010 T.I.R.

*Bore 'E'	Keyway
.500 - .562	.125 x .062
.625 - .875	.187 x .094
.937 - 1.250	.250 x .125
1.312 - 1.375	.312 x .156
1.437 - 1.750	.375 x .187
1.812 - 2.250	.500 x .250
2.312 - 2.500	.625 x .312

*Diameters are available in 0.062" increments.

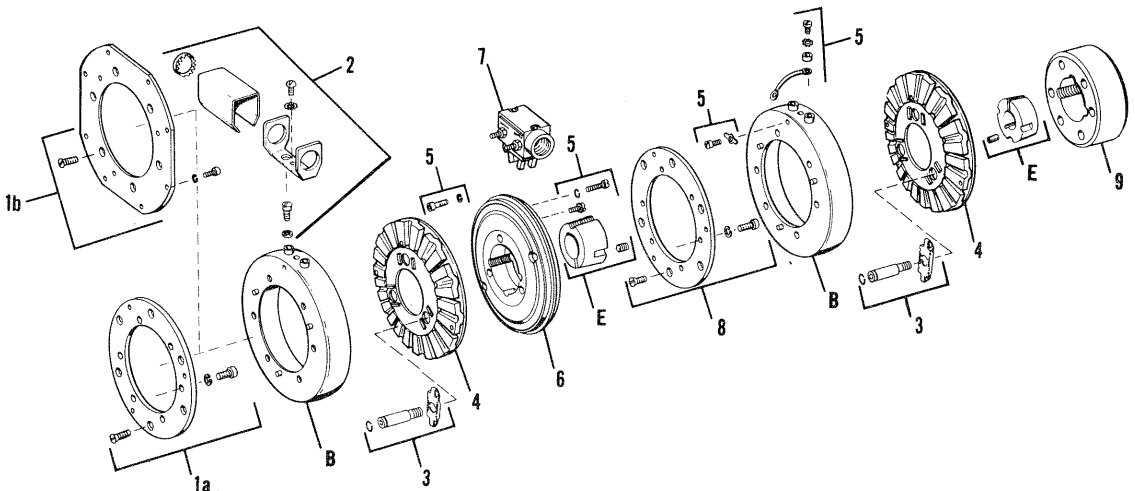

Model 310 Clutch-Brake Coupling Inside Mounted Per FC-310016
Model 310 Clutch-Brake Coupling Outside Mounted Per FC-310017

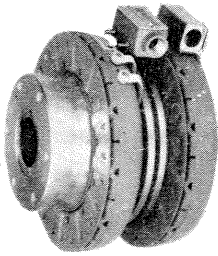

- Rotating Field
- Pin Drive

Item	Qty.	Part No.	Description
Major Parts			
1	1		Mounting Plate w/Accessories
1a		310481	Inside mounted
1b		310491	Outside mounted
2	1	326078	Brake Magnet Accessories
3	2	326075	Adjustable Gap Accessories
4	2	310380	Armature Plate Assembly Current Design is solid
5	1	326136	Clutch Magnet Accessories
6	1		Slip Ring & Hub Assembly
		310461 *	Right hand
		310471 *	Left hand (shown)
* Slip Ring 326012 only available see next page for details			
7	1	326019 **	Brush Holder Assembly
** Replaced by 326958			
Brushes available for old style see Service Parts			
8	1		Mounting Plate w/Accessories
		310481	Inside mounted
9	1	310450	Armature Hub
B	2		Field Magnet Assembly
		310373	24 volts
		310374	90 volts
E	2	326039	Split Taper Bushing (2517) (See note below)
Service Parts			
7a	4	326023	Brush

326012 Slip Ring

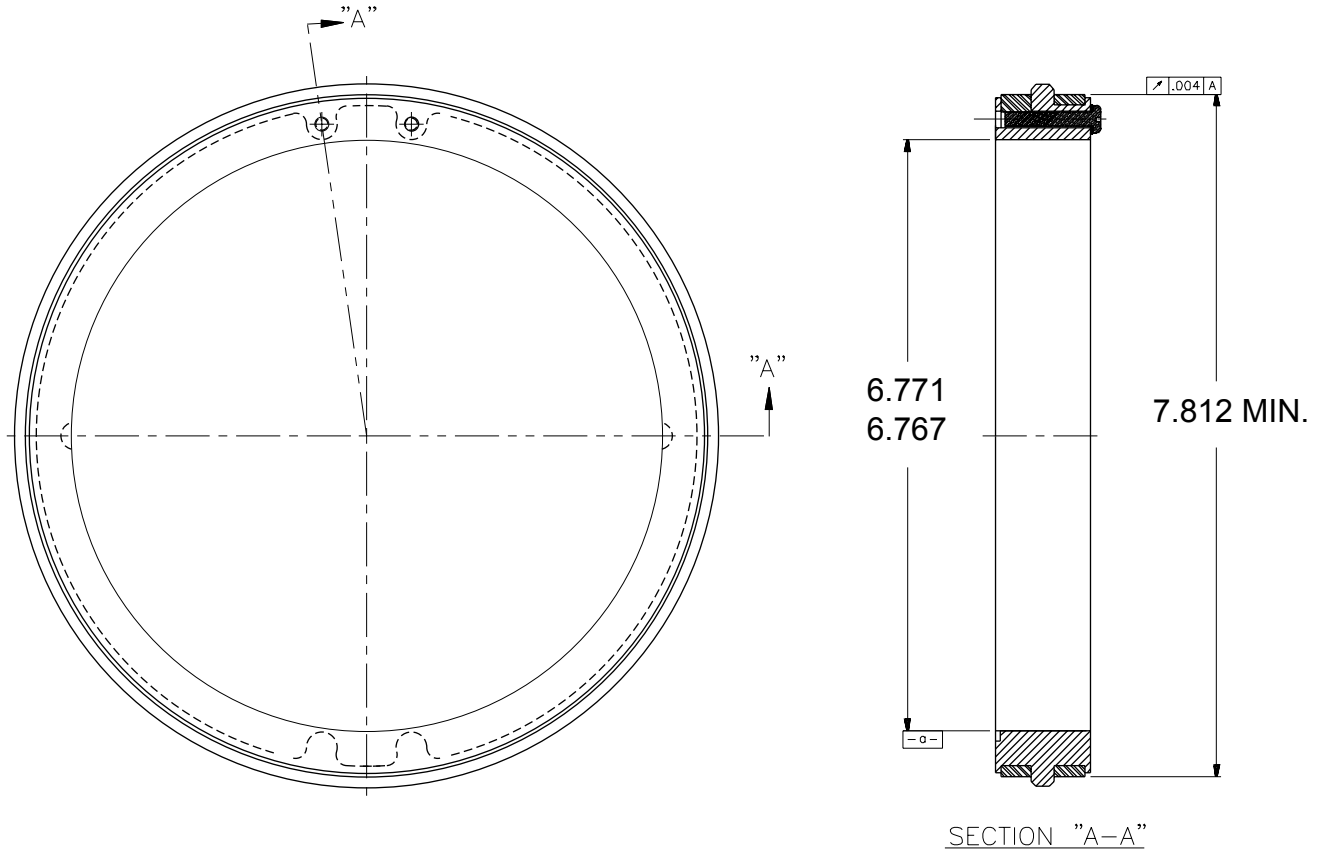

Use 326012 Slip Ring as Service Part for the following:
308461, 308471, 310461, 310471, 312461, 312471
315461, and 315471 Slip Ring and Hub Assembly

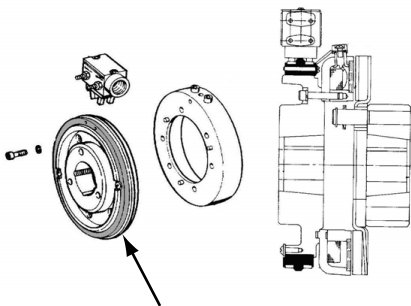

Slip Ring and Hub
Models 308 and 310

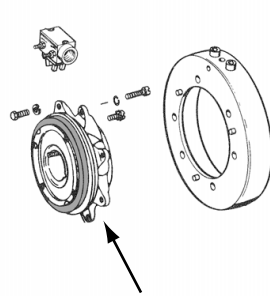

Slip Ring and Hub
Model 312

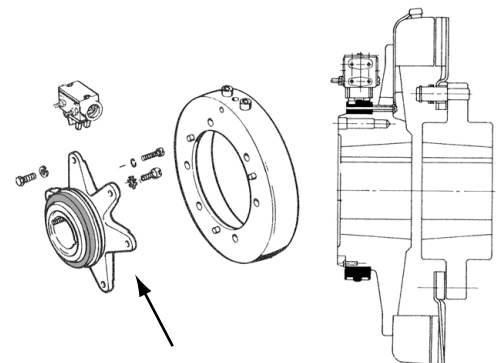

Slip Ring and Hub
Model 315

Sold & Serviced By:
ELECTROMATE

Toll Free Phone (877) SERV098
Toll Free Fax (877) 557-098
www.electromate.com
sales@electromate.com