

Clutch, Hi-Torque

SF-1525 H.T. Bearing Mounted

.397/.388 dia. (8) holes (hub) equally spaced on 3.625 dia. and within .003 of true position relative to 4.313/4.311 pilot diameter.

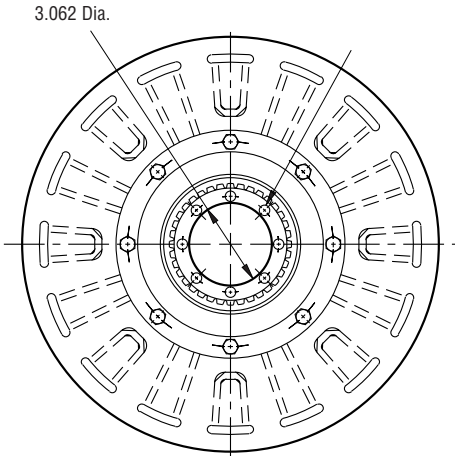
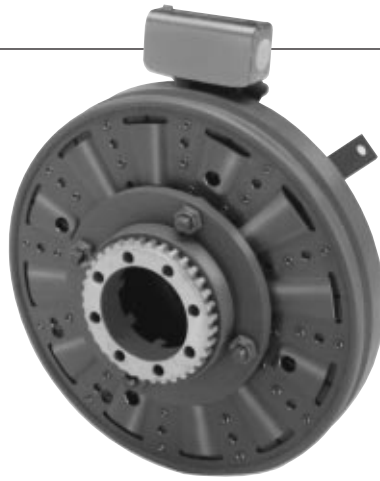

ARMATURE VIEW

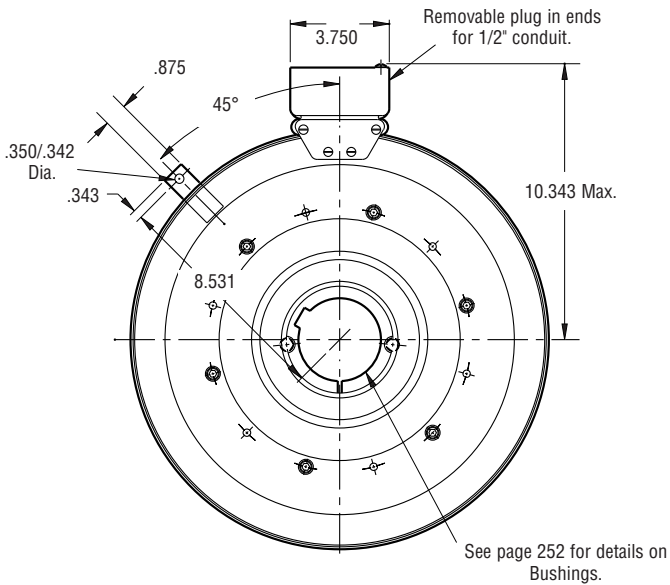

FIELD VIEW

Customer Shall Maintain:

1. Armature hub pilot diameter to be concentric with field and rotor mounting shaft within .010 T.I.R.

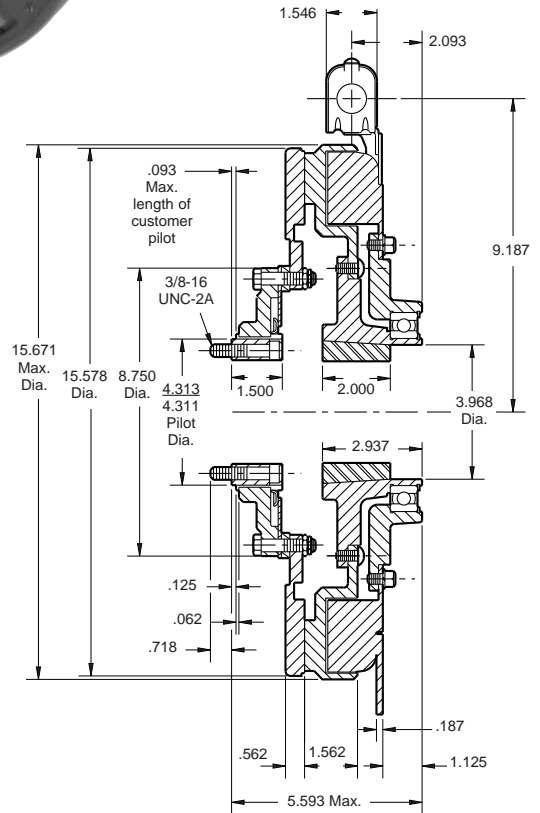

Shaft Size	.937– 3.000
Static Torque	1,350 lb.ft.
Maximum Speed	1,800 rpm
Standard Voltage	D.C. 90

All dimensions are nominal unless otherwise noted.

Information on inertia and weights begins on page 239. Coil data is on pages 250 and 251.



Drawing I-25643

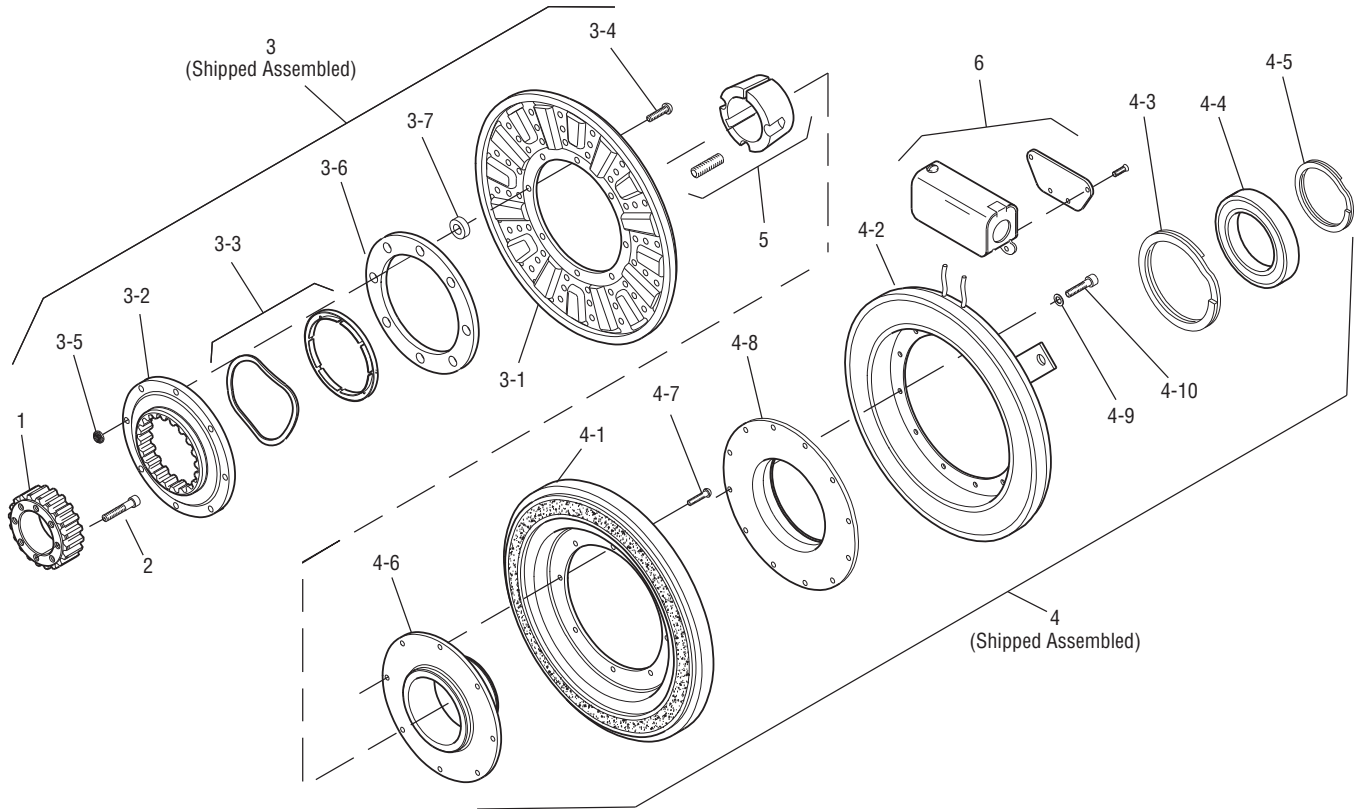

Item	Description	Part Number	Qty.
1	Splined Hub	540-0148	1
2	Accessory, Mounting	5202-101-001	1
3	Armature & Adapter Assembly	5204-111-004	1
3-1	Armature	5324-111-034	1
3-2	Splined Adapter	104-0011	1
3-3	Autogap Accessory	5323-101-002	1
3-4	Screw	797-0342	8
3-5	Locknut	661-0004	8
3-6	Retainer Plate	686-0003	1
3-7	Spacer	748-0333	8
4	Field & Rotor Assembly		1
	90 Volt	5204-452-015	
4-1	Rotor	5204-751-001	1
4-2	Field		1
	90 Volt	5204-451-090	
4-3	Retainer Ring	748-0114	1
4-4	Ball Bearing	166-0163	1
4-5	Retainer Ring	748-0583	1
4-6	Rotor Hub	540-1306	1

Item	Description	Part Number	Qty.
4-7	Buttonhead Screw	797-1261	8
4-8	Ring Adapter	748-1048	1
4-9	Lockwasher	950-0359	6
4-10	Sockethead Screw	797-0424	6
5	Bushing*	180-0223 to 180-0256	1
6	Conduit Box	5200-101-012	1

How to Order:

1. Specify Bore Size for Item 5.
2. Specify Voltage for Item 4.
3. See Controls Section.

Example:

SF-1525 Clutch Hi-Torque per I-25643 - 90 Volt, 1" Bore

These units, when used in conjunction with the correct Warner Electric conduit box, meet the standards of UL508 and are listed under guide card #NMTR, file #59164. These units are CSA certified under file #LR11543.

*See page 252 for specific part numbers.

Refer to Service Manual P-215.