

Clutch Coupling

PCC-500 Normal Duty

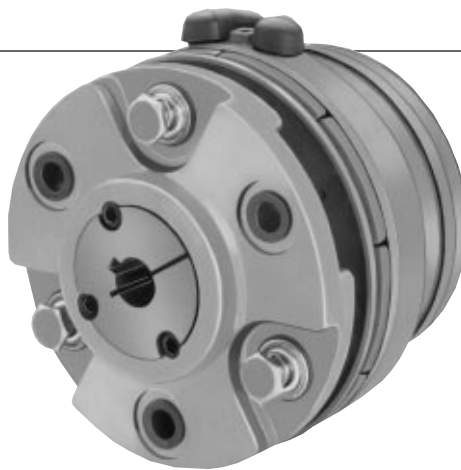

See page 252 for details on Bushings.

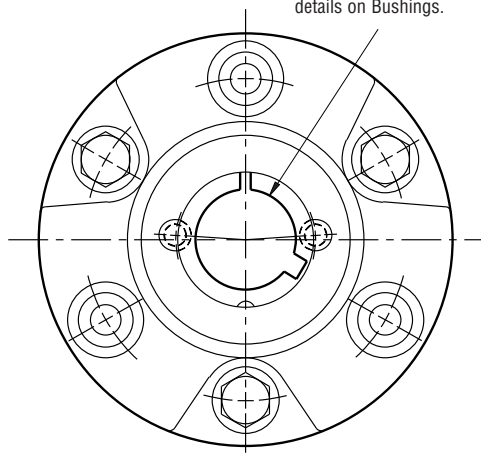

HUB VIEW

1/2-14 NPSM Am. std. straight pipe tap.

See page 252 for details on Bushings.

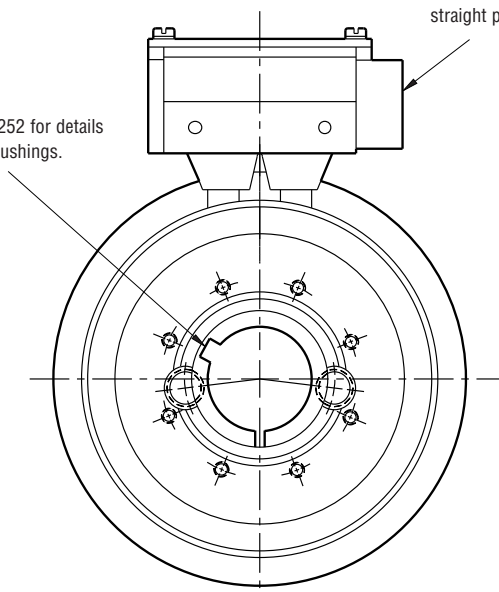

COLLECTOR RING VIEW

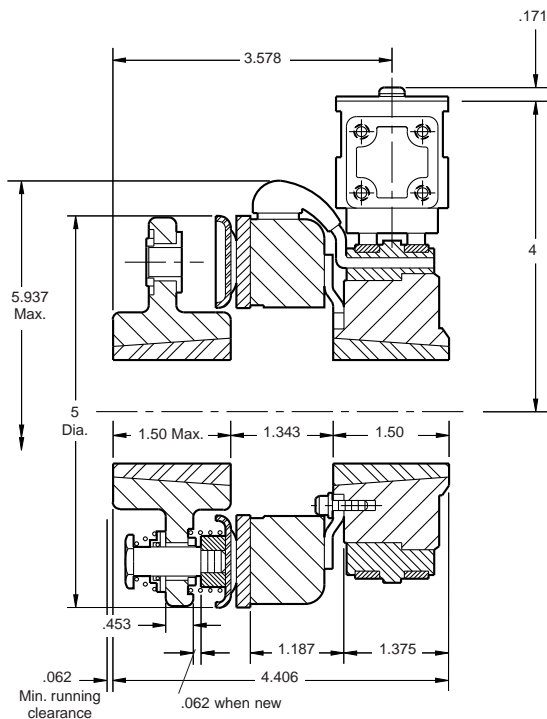

Armature Shaft	.500 – 1.250
Magnet Shaft	.500 – 1.250
Static Torque	40 lb.ft.
Maximum Speed	5,400 rpm
Standard Voltage	D.C. 6, 24, 90

All dimensions are nominal unless otherwise noted.

Information on inertia and weights begins on page 239. Coil data is on pages 250 and 251.

Customer Shall Maintain:

1. Armature mounting shaft concentric with magnet mounting shaft within .006 T.I.R.



Clutch Coupling

PCC-500 Normal Duty

Drawing I-25542

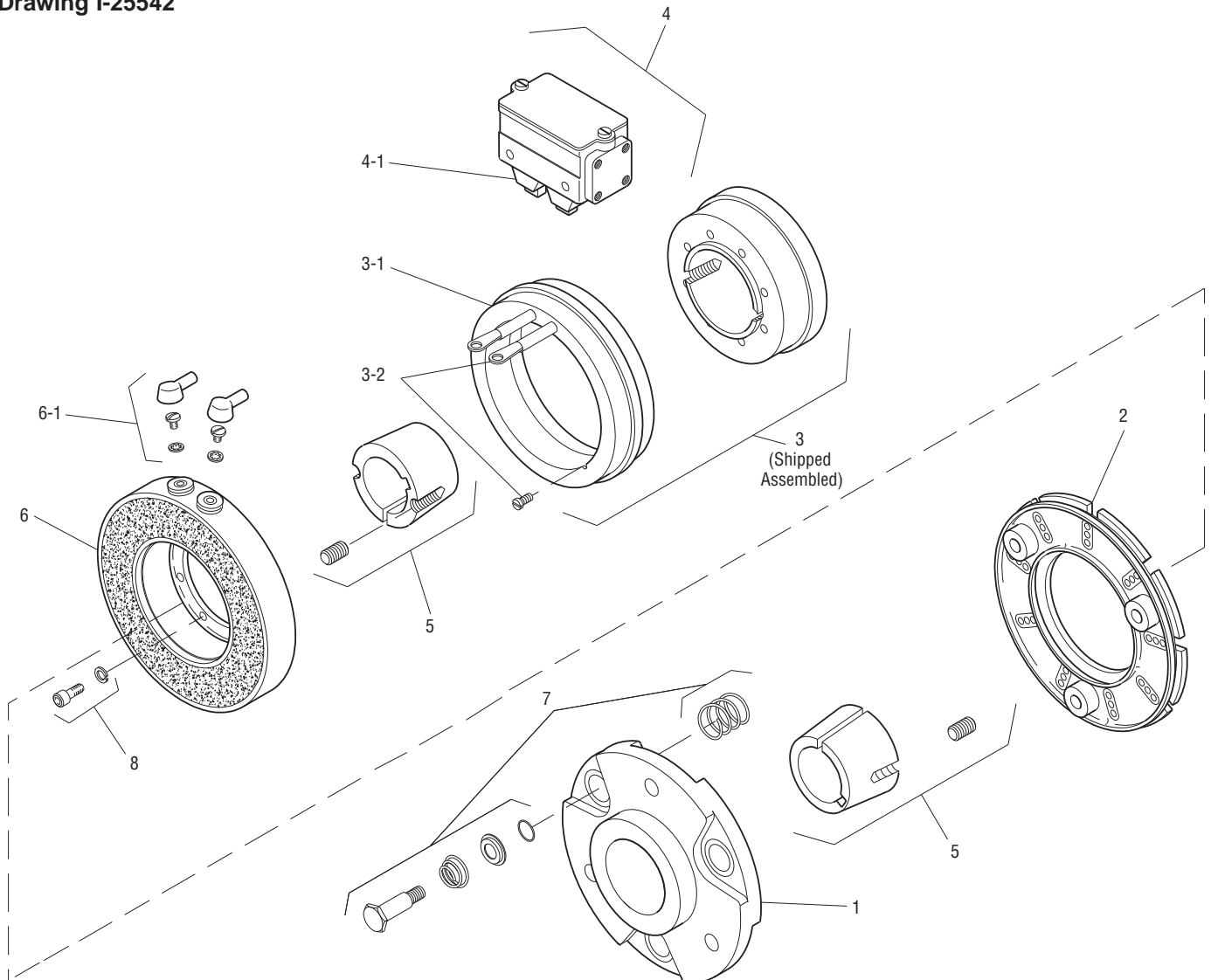

Item	Description	Part Number	Qty.
1	Armature Hub	5300-541-004	1
2	Armature	5300-111-002	1
3	Magnet Hub	5300-541-001	1
3-1	Collector Ring	5300-749-001	1
3-2	Collector Ring Mounting Accessory	5300-101-002	1
4	Brushholder	5300-178-001	1
4-1	Brush	176-0001	4
5	Bushing*		2
	1/2" to 1-1/4" Bore	180-0116 to 180-0128	
6	Magnet		
	6 Volt	5300-631-002	
	24 Volt	5300-631-003	
	90 Volt	5300-631-005	
6-1	Terminal Accessory	5311-101-001	1
7	Autogap Accessory	5200-101-009	3

Item	Description	Part Number	Qty.
8	Mounting Accessory	5102-101-001	2

How to Order:

1. Specify Bore Size for Item 5 (two shafts).
2. Specify Voltage for Item 7.
3. See Controls Section.

Example:

PCC-500 Clutch Coupling per I-25542 - 90 Volt
3/4" Bore

These units meet standards set forth in UL508 and are listed under guide card #NMTR2, file #59164.

These units are CSA certified under file #LR11543

*See page 252 for specific part numbers.

Refer to Service Manual P-203.

Sold & Serviced By:



Toll Free Phone (877) SERV098
Toll Free Fax (877) SERV099
www.electromate.com
sales@electromate.com