

Clutch Coupling

PCC-500 Heavy Duty

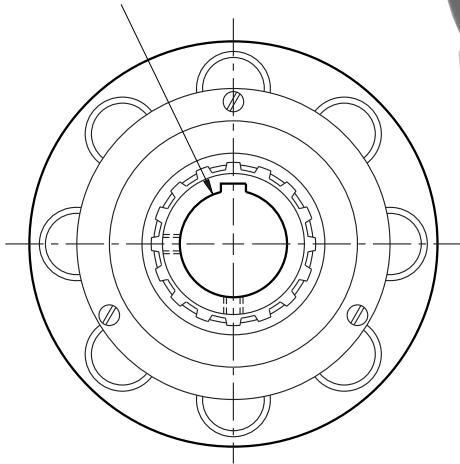

For Bore & Keyway sizes see chart below.



ARMATURE VIEW

See page 252 for details on Bushings.

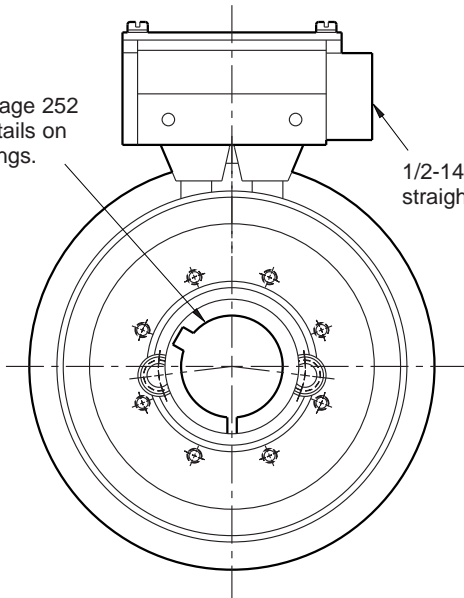

COLLECTOR RING VIEW

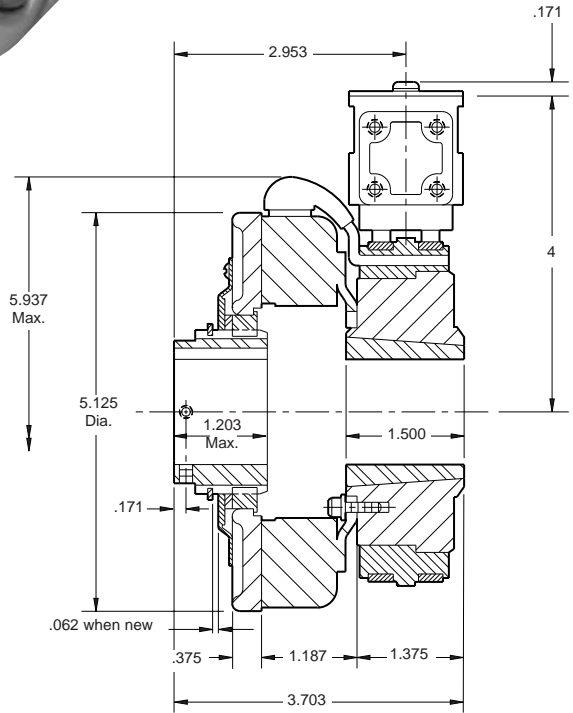

Bore & Keyway Dimensions

Armature Bore Dia.	Keyway
.751/.750	.187 x .093
.876/.875	
.9385/.9375	
1.001/1.000	.250 x .125
1.126/1.125	
1.251/1.250	

Armature Shaft	.750 – 1.250
Magnet Shaft	.500 – 1.250
Static Torque	40 lb.ft.
Maximum Speed	5,400 rpm
Standard Voltage	D.C. 6, 24, 90

All dimensions are nominal unless otherwise noted.

Information on inertia and weights begins on page 239. Coil data is on pages 250 and 251.

Customer Shall Maintain:

1. Armature mounting shaft concentric with magnet mounting shaft within .006 T.I.R.



Clutch Coupling

PCC-500 Heavy Duty

Drawing I-25543

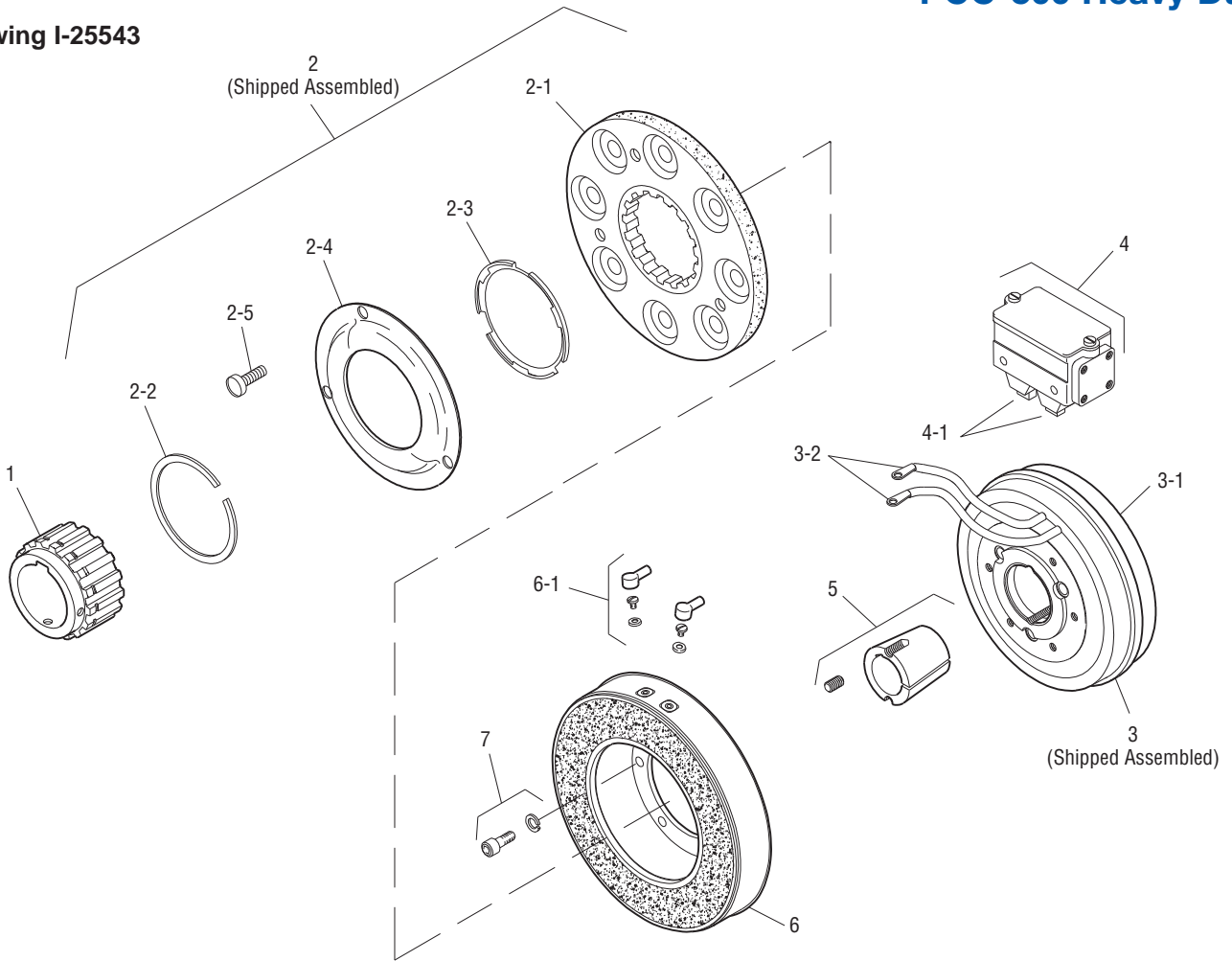

Item	Description	Part Number	Qty.
1	Armature Hub		1
	3/4" Bore	5200-541-002	
	7/8" Bore	5200-541-003	
	15/16" Bore	5200-541-004	
	1" Bore	5200-541-005	
	1-1/8" Bore	5200-541-006	
	1-1/4" Bore	5200-541-007	
2	Armature Assembly	5230-111-002	1
2-1	Armature	5230-111-001	1
2-2	Retainer Ring	748-0355	1
2-3	Autogap Spring	808-0412	1
2-4	Retainer Plate	748-0364	1
2-5	Screw	797-0028	3
3	Magnet Hub	5300-541-001	1
3-1	Collector Ring	5300-749-001	1
3-2	Collector Ring Mounting Acc.	5300-101-002	1
4	Brushholder	5300-178-001	1
4-1	Brush	176-0001	4
5	Bushing*		2
	1/2" to 1-1/4" Bore	180-0116 to 180-0128	

Item	Description	Part Number	Qty.
6	Magnet		1
	6 Volt	5300-631-002	
	24 Volt	5300-631-003	
	90 Volt	5300-631-005	
6-1	Terminal Accessory	5311-101-001	1
7	Mounting Accessory	5102-101-001	2

How to Order:

1. Specify Bore Size for Item 1 and Item 5.
2. Specify Voltage for Item 6.
3. See Controls Section.

Example:

PCC-500 Clutch Coupling per I-25543 - 90 Volt
 3/4" Armature Hub Bore
 1" Bushing Bore

These units meet standards set forth in UL508 and are listed under guide card #NMTR2, file #59164.

These units are CSA certified under file #LR11543.

*See page 252 for specific part numbers.

Refer to Service Manual P-203.

Sold & Serviced By:



Toll Free Phone (877) SERV098
 Toll Free Fax (877) SERV099
www.electromate.com
sales@electromate.com