

Clutch/Brake Coupling

PCBC-1225/1000

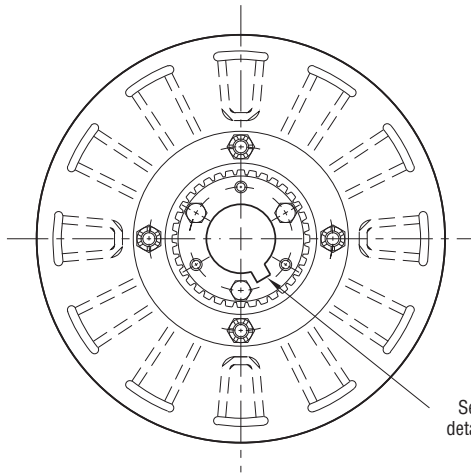

See page 252 for details on Bushings.

ARMATURE VIEW

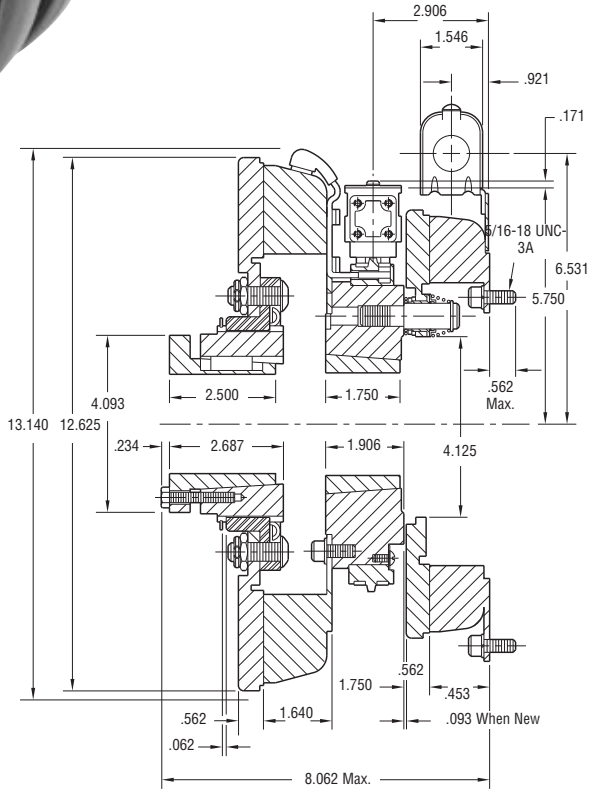

* Mounting holes are within .010 of true position relative to pilot diameter.

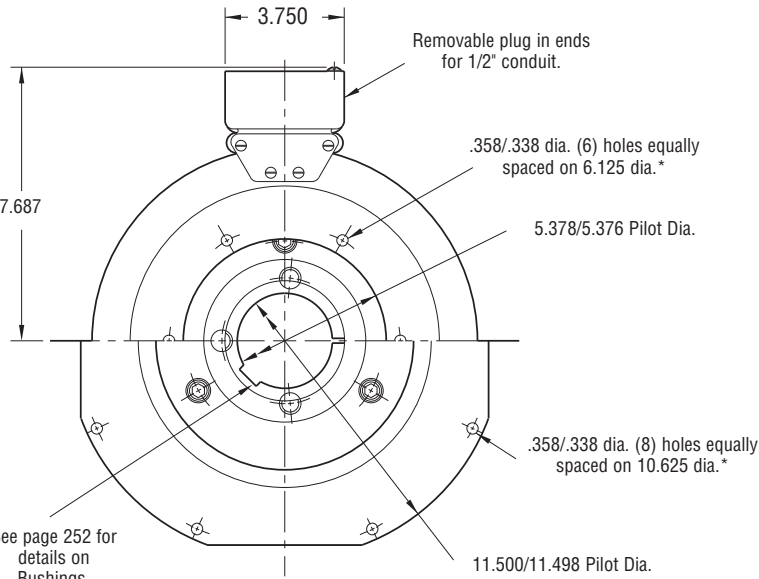

**MAGNET VIEW
(Inside & Outside Mounted)**

Customer Shall Maintain:

1. Armature mounting shaft concentric with magnet mounting shaft within .006 T.I.R.
2. Squareness of brake magnet mounting face with magnet mounting shaft within .006 T.I.R.
3. Concentricity of brake magnet mounting pilot diameter with magnet mounting shaft within .010 T.I.R.

Armature Shaft	.750 – 2.687
Magnet Shaft	.500 – 2.500
Static Torque Clutch	465 lb.ft.
Static Torque Brake	240 lb.ft.
Maximum Speed	3,000 rpm
Standard Voltage	D.C. 6, 90

All dimensions are nominal unless otherwise noted.

Information on inertia and weights begins on page 239. Coil data is on pages 250 and 251.



Drawing I-25613

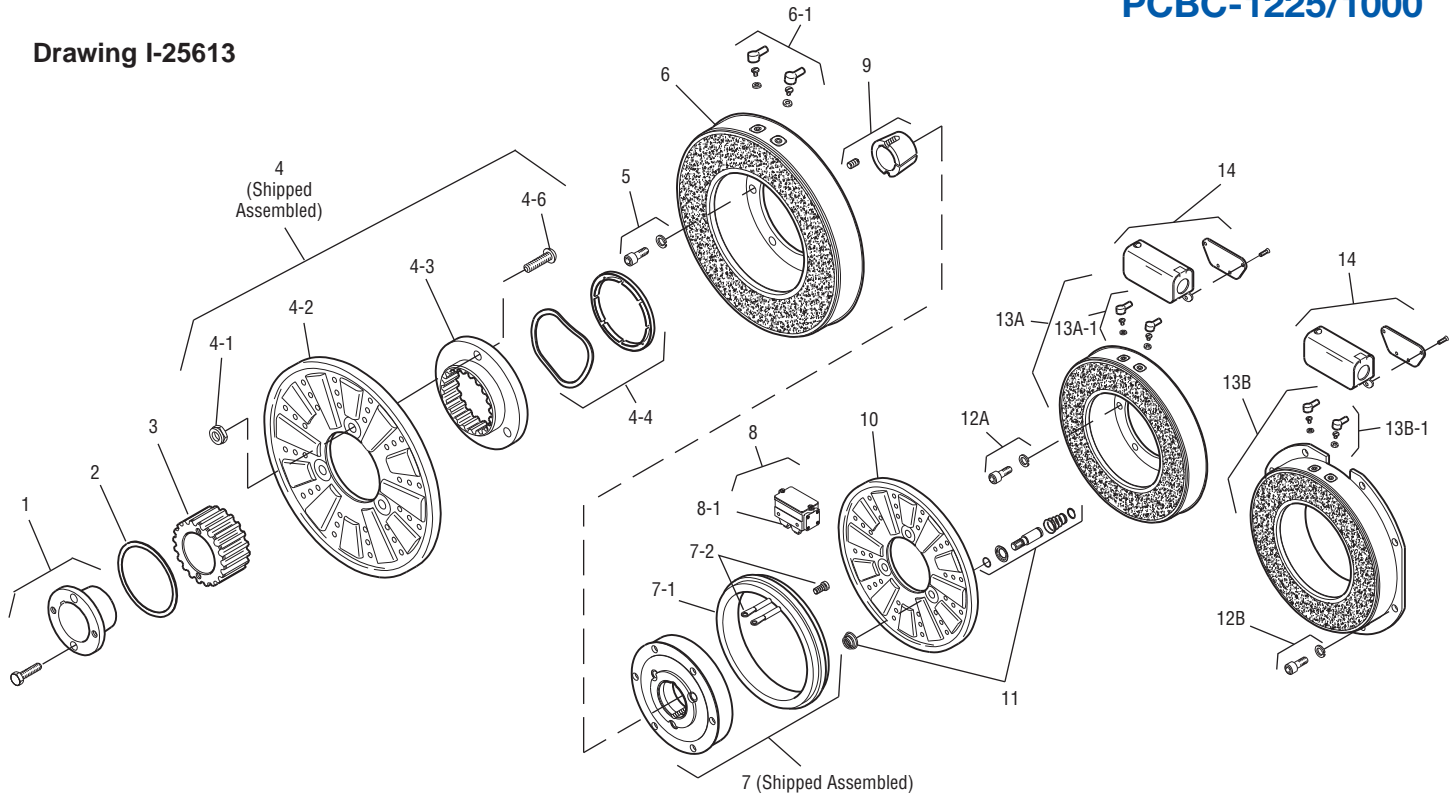

Item	Description	Part Number	Qty.
1	Bushing*		1
	3/4" to 2-11/16" Bore	180-0026 to 180-0057	
2	Retainer Ring	748-0005	1
3	Splined Hub	540-0064	1
4	Armature & Splined Adapter	5323-111-001	1
4-1	Locknut	661-0005	4
4-2	Armature	5323-111-034	1
4-3	Splined Adapter	104-0010	1
4-4	Autogap Accessory	5323-101-002	1
4-6	Screw	797-0281	4
5	Mounting Accessory	5321-101-001	1
6	Magnet		1
	6 Volt	5333-631-008	
	90 Volt	5333-631-009	
	†90 Volt LK Facing	5333-631-013	
6-1	Terminal Accessory	5311-101-001	1
7	Magnet Hub		1
	Left Hand (shown)	5302-541-004	
	Right Hand	5302-541-005	
7-1	Collector Ring	5301-749-001	1
7-2	Collector Ring Accessory	5303-101-004	1
8	Brushholder	5300-178-001	1
8-1	Brush	176-0001	4
9	Bushing*		1
	1/2" to 2-1/2" Bore	180-0185 to 180-0217	
10	Armature	5302-111-013	1
11	Autogap Accessory	5201-101-008	3
12A	Mounting Accessory - I.M.	5321-101-001	1

Item	Description	Part Number	Qty.
12B	Mounting Accessory - O.M.	5321-101-002	2
13A	Magnet - Inside Mounted		1
	6 Volt	5312-631-004	
	90 Volt	5312-631-006	
13A-1	Terminal Accessory	5311-101-001	1
13B	Magnet - Outside Mounted		1
	6 Volt	5312-631-011	
	90 Volt	5312-631-012	
13B-1	Terminal Accessory	5311-101-001	1
14	Conduit Box	5200-101-011	1

How to Order:

1. Specify Bore Size for Item 1 and 9.
2. Specify Voltage for Item 6 and Item 13A or 13B.
3. Specify left hand or right hand hub for Item 7. Bushing enters from magnet side for L.H. hub and from hub side for R.H.
4. Specify Inside Mounted for Items 12A and 13A or Outside Mounted for Items 12B and 13B.
5. See Controls Section.

Example:

PCBC-1225/1000 Clutch Brake Coupling per I-25613 - 90 Volt, Inside Mounted, Left Hand hub, 1-3/4" Bore, (Items 1 and 9).

These units meet standards set forth in UL508 and are listed under guide card #NMTR2, file #59164. These units are CSA certified under file #LR11543.

*See page 252 for specific part numbers.

Refer to Service Manual P-214.

†Optional LK facing available. For more information, see page 232.