

Clutch/Brake

PCB-1225/1000 Normal Duty

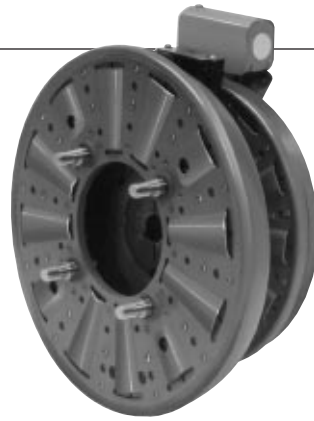

See page 252 for details on Bushings.

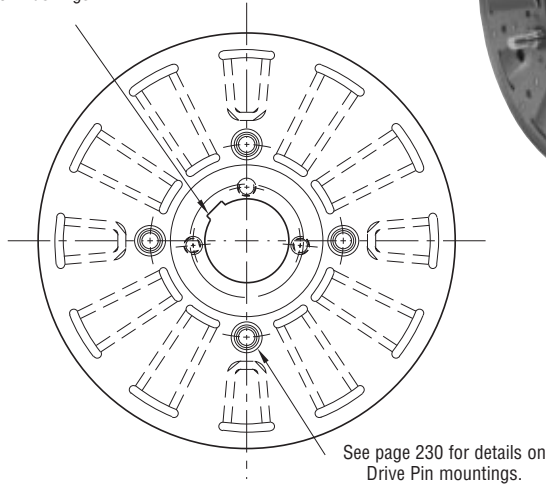

ARMATURE VIEW

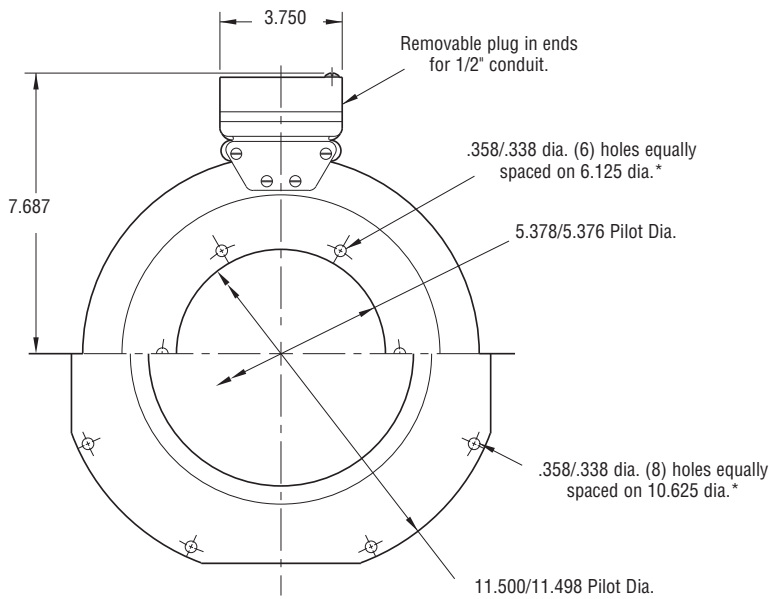

MAGNET VIEW
(Inside & Outside Mounted)

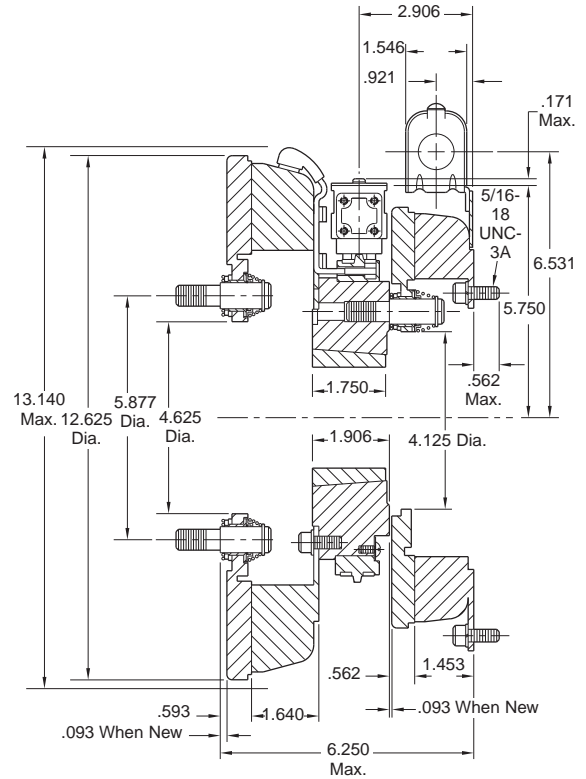

* Mounting holes are within .010 of true position relative to pilot diameter.

Shaft Size	.500 – 2.500
Static Torque Clutch	465 lb. ft.
Static Torque Brake	240 lb. ft.
Maximum Speed	3,000 rpm
Standard Voltage	D.C. 6, 24, 90

Customer Shall Maintain:

1. Concentricity of brake mounting pilot diameter with mounting shaft within .010 T.I.R.
2. Squareness of brake magnet mounting face with mounting shaft within .006 T.I.R. measured at magnet mounting bolt circle.

All dimensions are nominal unless otherwise noted.

Information on inertia and weights begins on page 239. Coil data is on pages 250 and 251.



Drawing I-25610

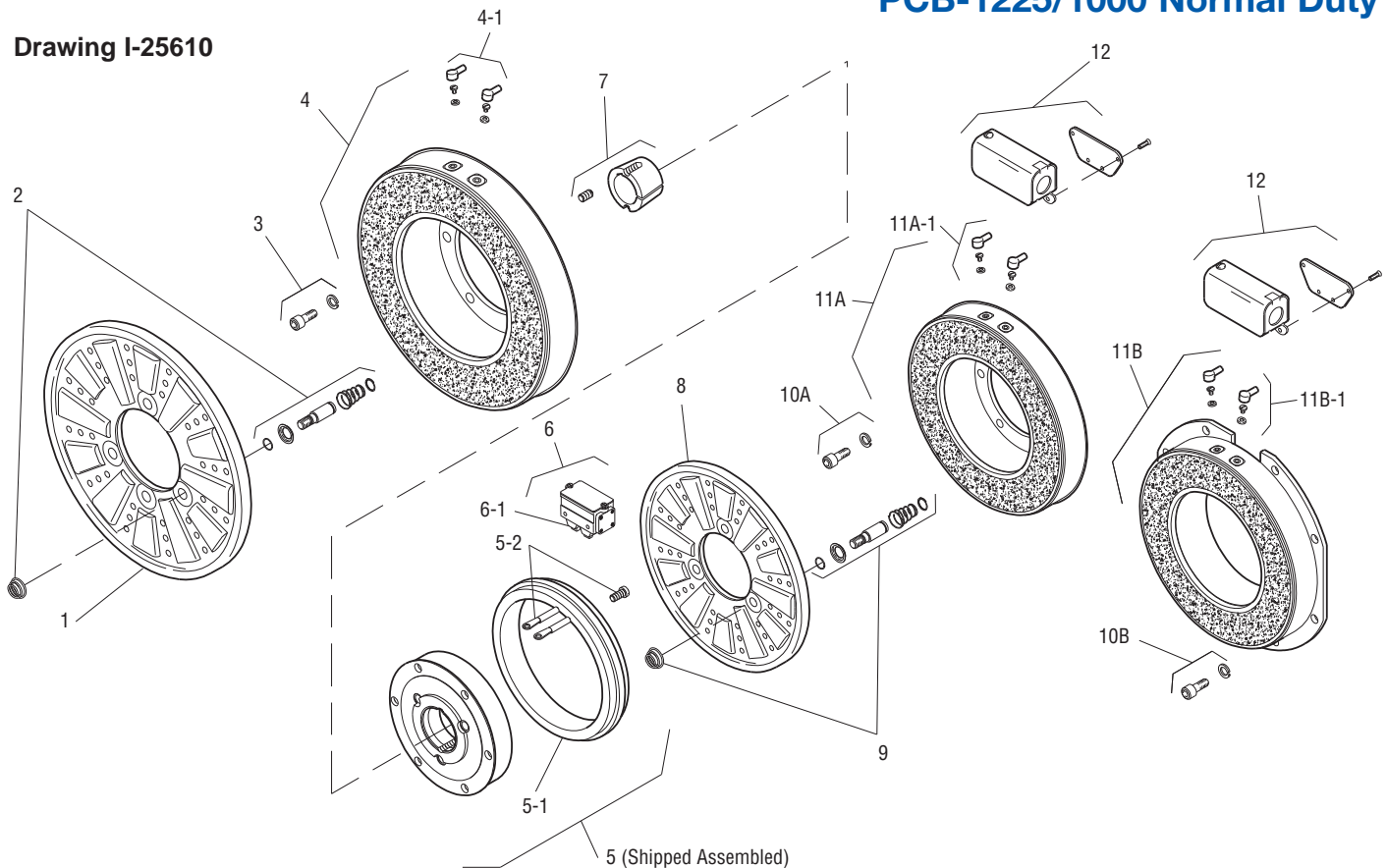

Item	Description	Part Number	Qty.
1	Armature	5303-111-009	1
2	Autogap Accessory	5201-101-008	4
3	Mounting Accessory	5321-101-001	1
4	Magnet		1
	6 Volt	5333-631-008	
	90 Volt	5333-631-009	
	†90 Volt LK Facing	5333-631-013	
4-1	Terminal Accessory	5311-101-001	1
5	Magnet Hub		1
	Left Hand (shown)	5302-541-004	
	Right Hand	5302-541-005	
5-1	Collector Ring	5301-749-001	1
5-2	Collector Ring Accessory	5303-101-004	1
6	Brushholder	5300-178-001	1
6-1	Brush	176-0001	4
7	Bushing*		1
	1/2" to 2-1/2" Bore	180-0185 to 180-0217	
8	Armature	5302-111-013	1
9	Autogap Accessory	5201-101-008	3
10A	Mounting Accessory - I.M.	5321-101-001	1
10B	Mounting Accessory - O.M.	5321-101-002	2
11A	Magnet - Inside Mounted		1
	6 Volt	5312-631-004	
	24 Volt	5312-631-005	
	90 Volt	5312-631-006	

Item	Description	Part Number	Qty.
11A-1	Terminal Accessory	5311-101-001	1
11B	Magnet - Outside Mounted		1
	6 Volt	5312-631-011	
	24 Volt	5312-631-013	
	90 Volt	5312-631-012	
11B-1	Terminal Accessory	5311-101-001	1
12	Conduit Box	5200-101-011	1

How to Order:

1. Specify Voltage for Item 4 and Item 11A or 11B.
2. Specify left hand or right hand hub for Item 5. Bushing enters from magnet side for L.H. hub and from hub side for R.H.
3. Specify Bore Size for Item 7.
4. Specify Inside Mounted for Items 10A and 11A or Outside Mounted for Items 10B and 11B.
5. See Controls Section.

Example:

PCB-1225/1000 Clutch Brake per I-25610 - 90 Volt, Left Hand hub, 1-1/2" Bore, Inside Mounted

These units meet the standards of UL508 and are listed under guide card #NMTR2, file #59164. These units are CSA certified under file #LR11543.

*See page 252 for specific part numbers.

Refer to Service Manual P-214.

†Optional LK facing available. For more information, see page 232.