

Clutch/Brake

PCB-1225/1000 Heavy Duty

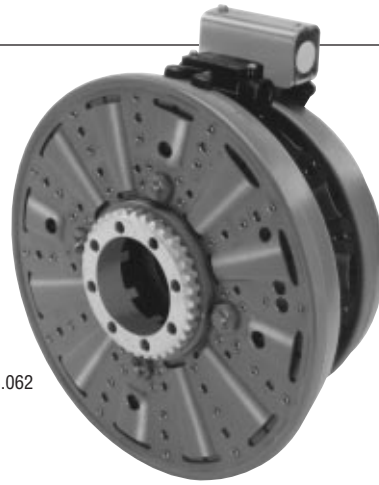

.397/.388 dia. (8) holes (hub) equally spaced on (3.625) dia. and within .003 of true position in relation to 4.313/4.311 pilot dia.

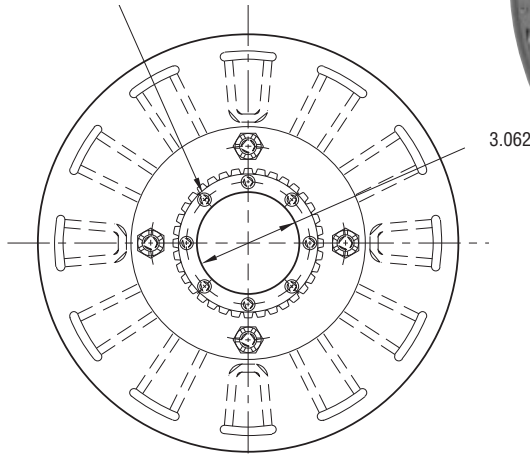

ARMATURE VIEW

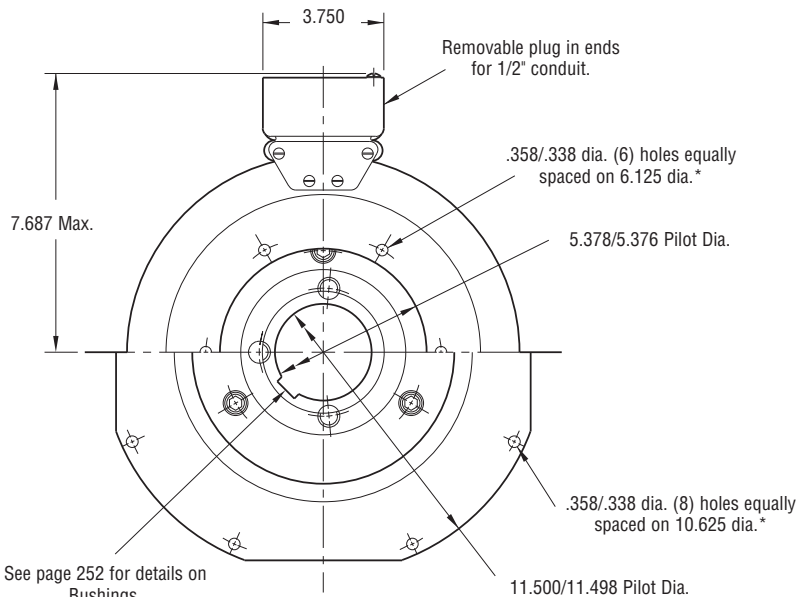

MAGNET VIEW

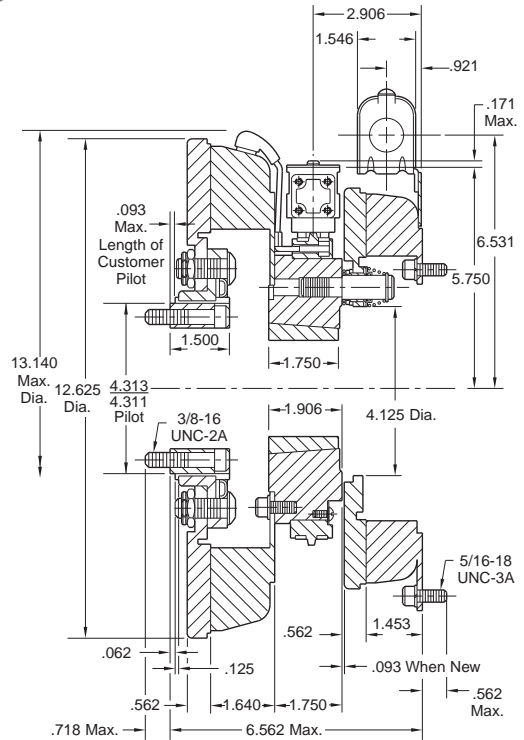

* Mounting holes are within .010 of true position relative to pilot diameter.

Shaft Size	.500 – 2.500
Static Torque Clutch	465 lb. ft.
Static Torque Brake	240 lb. ft.
Maximum Speed	3,000 rpm
Standard Voltage	D.C. 6, 24, 90

All dimensions are nominal unless otherwise noted.

Information on inertia and weights begins on page 239. Coil data is on pages 250 and 251.

Customer Shall Maintain:

1. Concentricity of brake magnet mounting pilot diameter to mounting shaft within .010 T.I.R.
2. Squareness of brake magnet mounting face to magnet mounting shaft within .006 T.I.R.
3. Splined hub pilot diameter to be concentric with splined armature center of rotation within .010 T.I.R.



Drawing I-25611

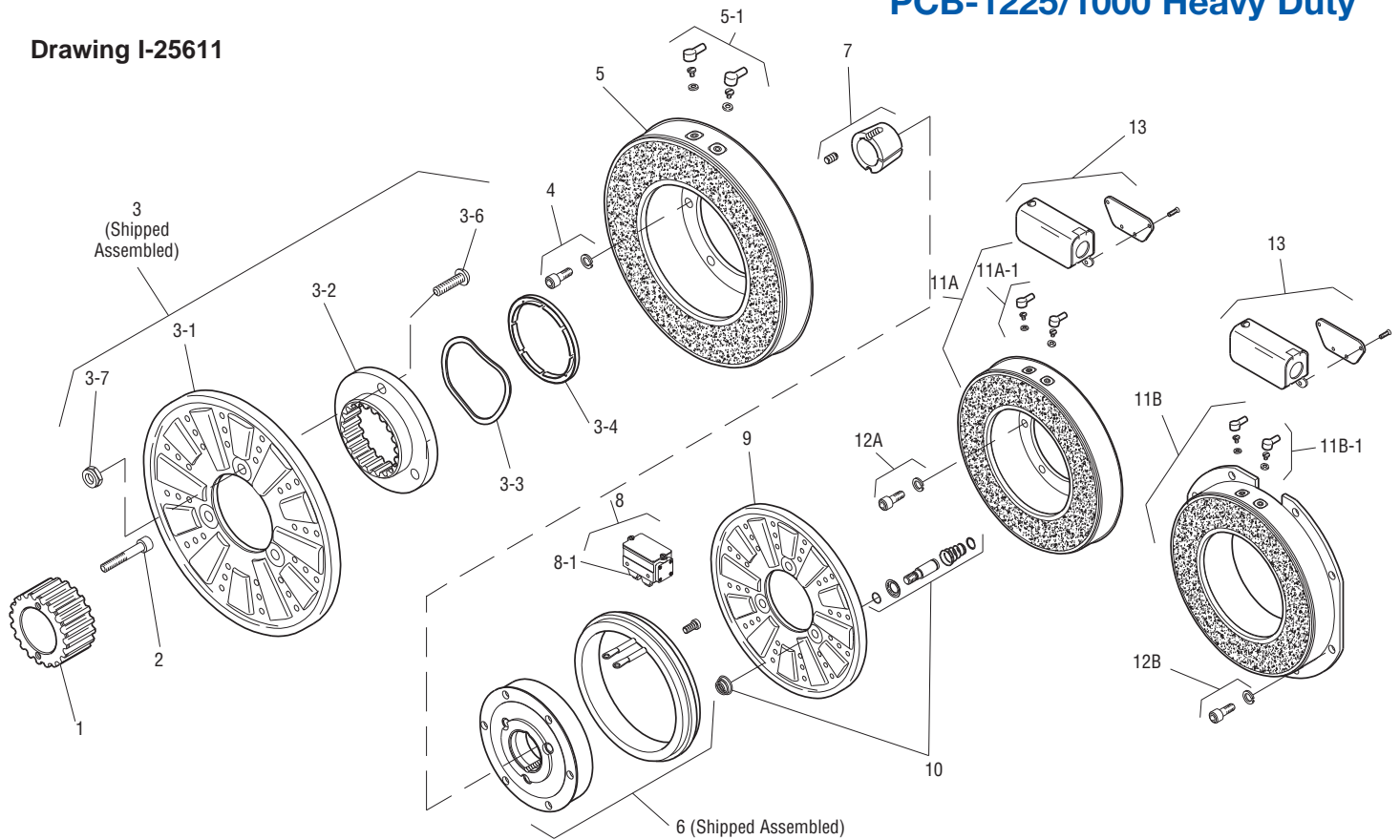

Item	Description	Part Number	Qty.
1	Splined Hub	540-0148	1
2	Mounting Accessory	5202-101-001	1
3	Armature Assembly	5323-111-001	1
3-1	Armature	5323-111-034	1
3-2	Splined Armature Adapter	104-0010	1
3-3	Autogap Spring	808-0044	1
3-4	Retainer Ring	748-0370	1
3-6	Buttonhead Screw	797-0281	4
3-7	Locknut	661-0005	4
4	Mounting Accessory	5321-101-001	1
5	Magnet Assembly		1
	6 Volt	5333-631-008	
	90 Volt	5333-631-009	
	†90 Volt LK Facing	5333-631-013	
5-1	Terminal Accessory	5311-101-001	1
6	Hub Assembly		
	Left Hand (shown)	5302-541-004	1
	Right Hand	5302-541-005	1
7	Bushing*	180-0185 to 180-0217	1
8	Brushholder	5300-178-001	1
8-1	Brush	176-0001	4
9	Armature Assembly	5302-111-013	1
10	Autogap Accessory	5201-101-008	3
11A	Magnet I.M.		1
	6 Volt	5312-631-004	
	24 Volt	5312-631-005	
	90 Volt	5312-631-006	
11A-1	Terminal Accessory	5311-101-001	1

Item	Description	Part Number	Qty.
11B	Magnet - Outside Mounted		1
	6 Volt	5312-631-011	
	24 Volt	5312-631-013	
	90 Volt	5312-631-012	
11B-1	Terminal Accessory	5311-101-001	1
12A	Mounting Accessory I.M.	5321-101-001	1
12B	Mounting Accessory O.M.	5321-101-002	2
13	Conduit Box	5200-101-011	1

How to Order:

1. Specify Voltage for Item 5 and Item 11A or 11B.
2. Specify left hand or right hand hub for Item 6. Bushing enters from magnet side for L.H. hub and from hub side for R.H.
3. Specify Bore Size for Item 7.
4. Specify Inside Mounted for Items 11A and 12A or Outside Mounted for Items 11B and 12B.
5. See Controls Section.

Example:

PCB-1225/1000 Clutch Brake per I-25611- 90 Volt, Left Hand hub, 1-1/2" Bore, Inside Mounted

These units meet the standards of UL508 and are listed under guide card #NMTRs, file #59164. These units are CSA certified under file #LR11543.

*See page 252 for specific part numbers.

Refer to Service Manual P-214.

†Optional LK facing available. For more information, see page 232.

Sold & Serviced By:



Toll Free Phone (877) SERV098
Toll Free Fax (877) SERV099
www.electromate.com
sales@electromate.com