

Brake

PB-1525 Normal Duty

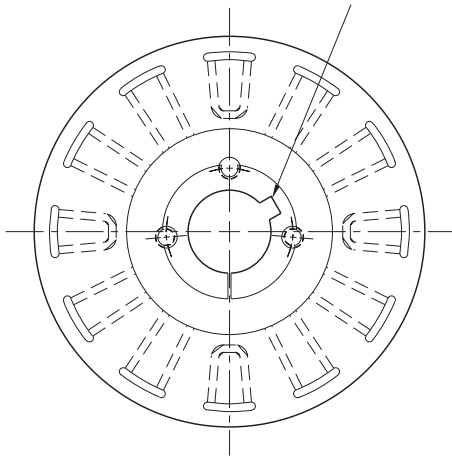

See page 252 for details on Bushings.



ARMATURE VIEW

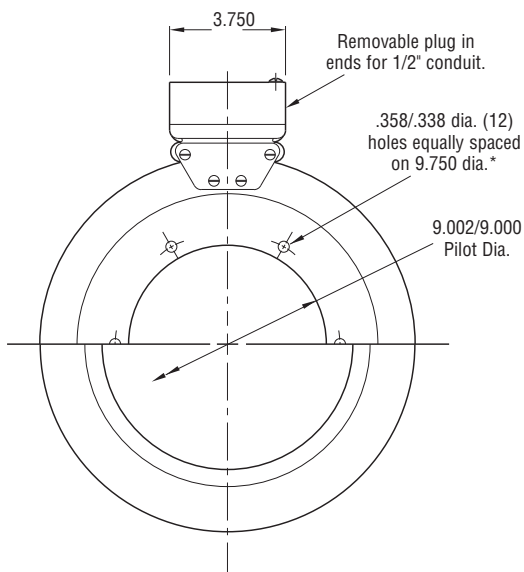

**MAGNET VIEW
(Inside & Outside Mounted)**

* Mounting holes are within .010 of true position relative to pilot diameter.

Customer Shall Maintain:

1. Squareness of magnet mounting face with armature shaft within .006 T.I.R.
2. Concentricity of magnet mounting pilot diameter with armature shaft within .010 T.I.R.

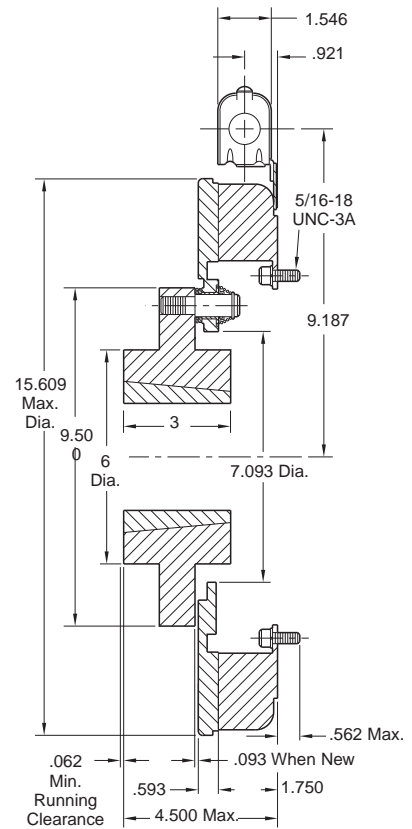

Shaft Size	.937 – 3.000
Static Torque	700 lb. ft.
Maximum Speed	2,000 rpm
Standard Voltage	D.C. 6, 24, 90

All dimensions are nominal unless otherwise noted.

Information on inertia and weights begins on page 239. Coil data is on pages 250 and 251.



Drawing I-25633

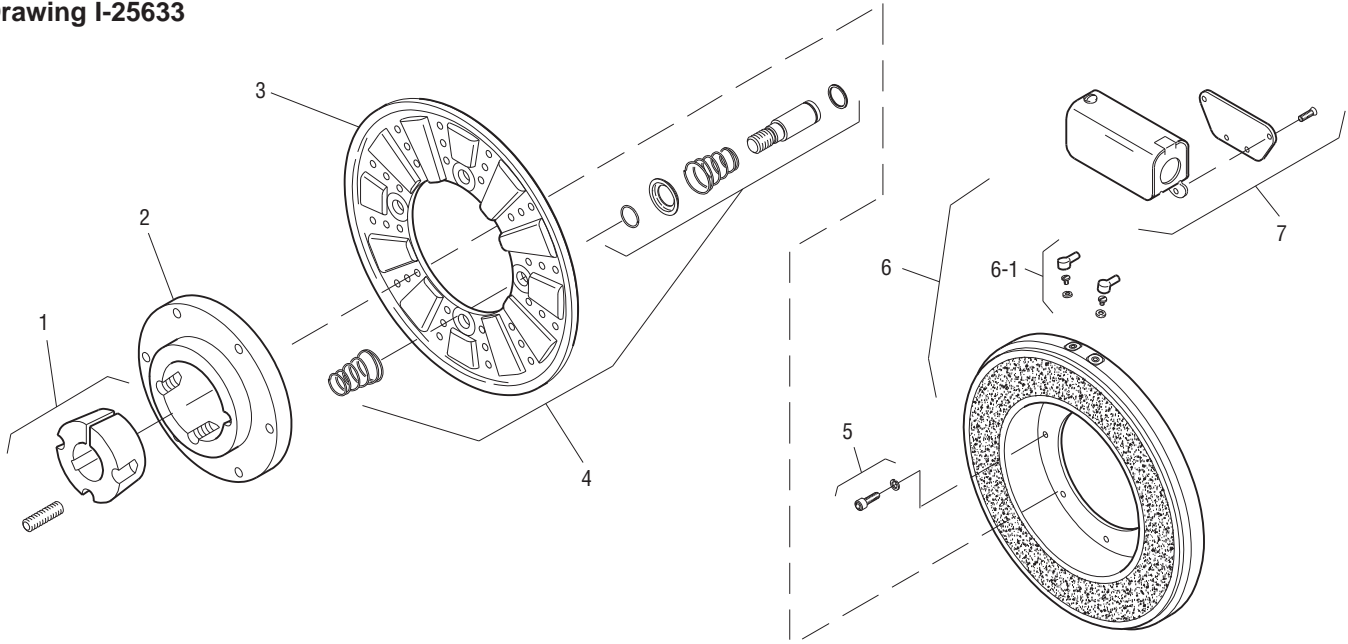

Item	Description	Part Number	Qty.
1	Bushing*		1
	15/16" to 3" Bore	180-0262 to 180-0295	
2	Armature Hub	540-0314	1
3	Armature	5304-111-004	1
4	Autogap Accessory	5201-101-008	4
5	Mounting Accessory - I.M.	5321-101-001	2
6	Magnet - Inside Mounted		1
	6 Volt	5314-631-004	
	24 Volt	5314-631-006	
	90 Volt	5314-631-005	
	†90 Volt	5314-631-001	
6-1	Terminal Accessory	5311-101-001	1
7	Conduit Box	5200-101-011	1

How to Order:

1. Specify Bore Size for Item 1.
2. Specify Inside Mounted for Items 5 and 6.
3. Specify Voltage for Item 6.
4. See Controls Section.

Example:

PB-1525 Brake per I-25633 - 90 Volt,
1-1/2" Bore, Inside Mounted

These units, when used in conjunction with the correct Warner Electric conduit box, meet the standards of UL508 and are listed under guide card #NMTR, file #59164. These units are CSA certified under file #LR11543.

*See page 252 for specific part numbers.

Refer to Service Manual P-208.