

Flange Mounted Brake

Model

● 305

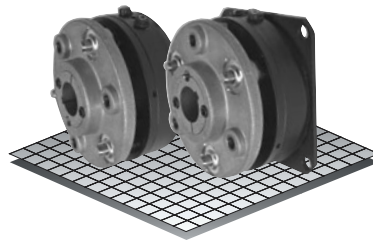

▶ Flange Mounted
▶ Pin Drive

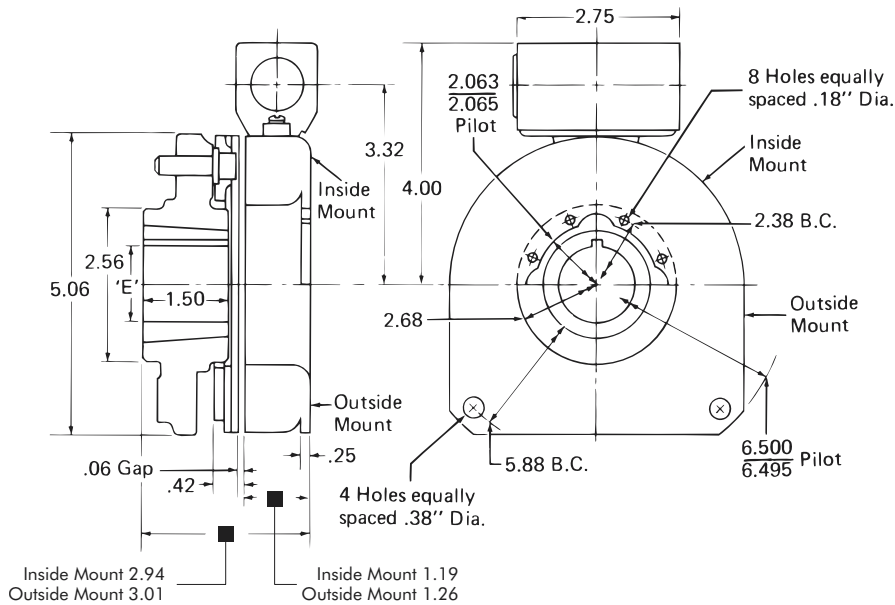

Bushing 1215

Bore 'E'		Keyway	Part No.
1/2"	.500	.125 x .062	326058 - 1
9/16"	.562	.125 x .062	326058 - 2
5/8"	.625	.187 x .093	326058 - 3
11/16"	.687	.187 x .093	326058 - 4
3/4"	.750	.187 x .093	326058 - 5
13/16"	.812	.187 x .093	326058 - 6
7/8"	.875	.187 x .093	326058 - 7
15/16"	.937	.250 x .125	326058 - 8
1"	1.000	.250 x .125	326058 - 9
1-1/16"	1.062	.250 x .125	326058 - 10
1-1/8"	1.125	.250 x .125	326058 - 11
1-3/16"	1.187	.250 x .125	326058 - 12
1-1/4"	1.250	.250 x .125	326058 - 13

Technical Data and Torque (In. Lb.)

Model No.	Wt. Lbs.	Static Torque in. lb.	Max. Speed RPM	Coil Voltage vdc	* Rated Current amps	RPM									
						0	300	600	900	1200	1500	1800	2400	3000	3600
305	3.5	684	3600	90	.41	684	624	564	516	468	420	384	324	288	252

* Rated current at 90v.

Refer to Section M for torque and heat dissipation curves.

Customer must maintain:

1. Concentricity between mounting flange and shaft within .006.
2. Perpendicularity between mounting surface and shaft within .006.

Order Parts for Assembly No. FC305050 and FC305051

	Armature Hub Assembly	Armature Plate Assembly	Magnet Accessory	(1215) Taper Bushing	FC305050	FC305051
					Magnet	
					Inside Mounted	Outside Mounted
24 Volts	305450	305381	326143	326058-XX	305343	305353
90 Volts	305450	305381	326143	326058-XX	305344	305354

To order, specify: 1, Armature Hub
1, Armature Plate Assembly
1, Magnet Accessory
1, Taper Bushing (1215) of required Bore size
1, Magnet of required Voltage for either Inside Mount or Outside Mount

For controls, see Section K.

Sold & Serviced By:
ELECTROMATE
Toll Free Phone (877) SERV098
Toll Free Fax (877) SERV099
www.electromate.com
sales@electromate.com

Flange Mounted Brake

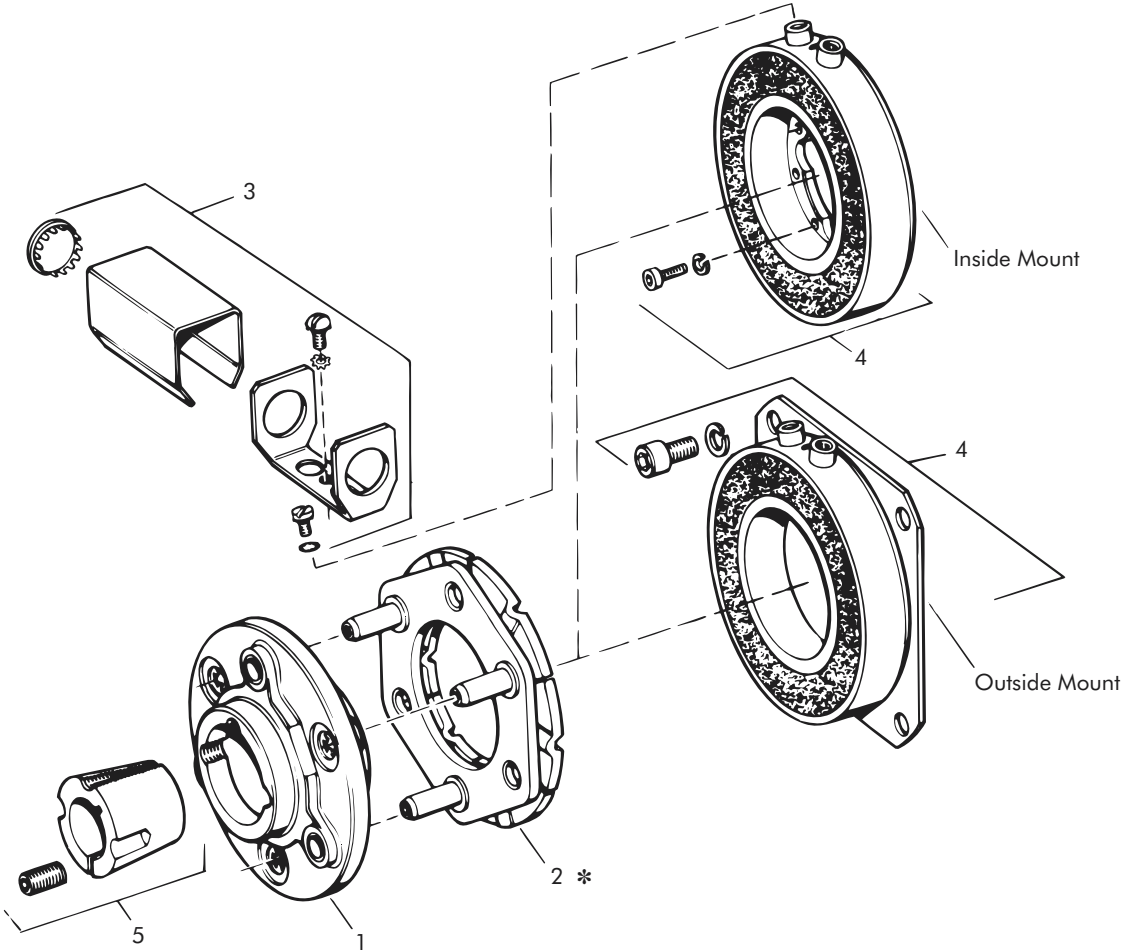

Replacement Parts

Item	Qty.	Description	Part No.
1	1	Armature Hub Assembly	305450
2	1	Armature Plate Assembly	305381
3	1	Magnet Accessory	326143
4	1	Magnet	
		24 Volts, inside mounted	305343
		90 Volts, inside mounted	305344
		24 Volts, outside mounted	305353
		90 Volts, outside mounted	305354
5	1	Taper Bushing (1215)	326058-XX

* Current design armatures are solid.