

# Flange Mounted Brake

Model

● 303

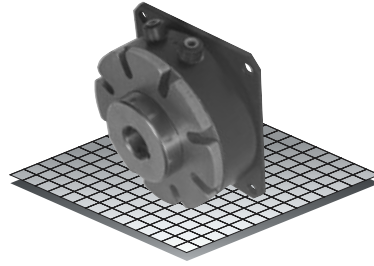

▶ Flange Mounted  
▶ Spline Drive

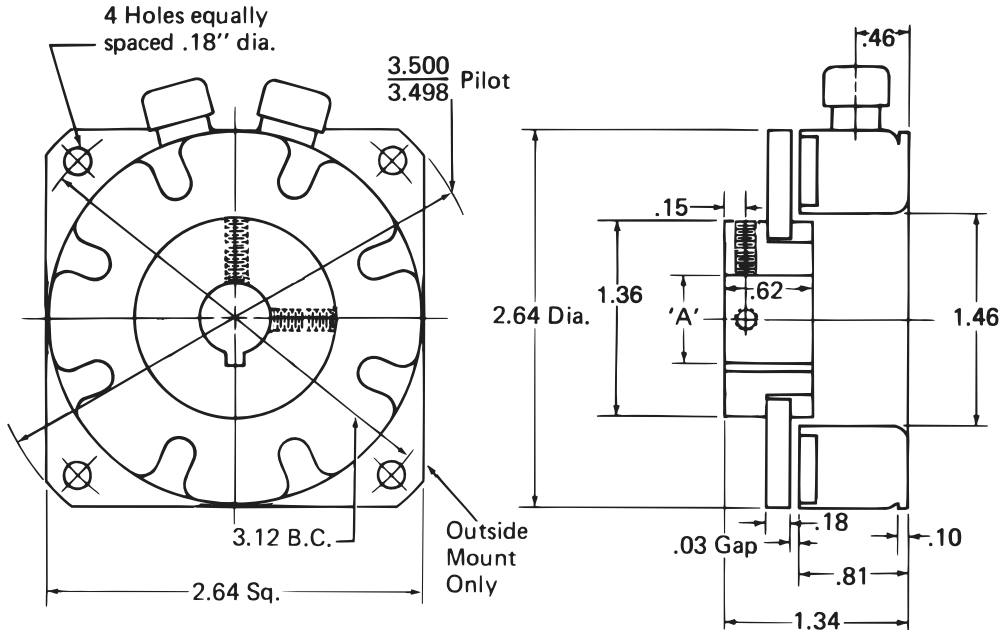

"A" Bore	Keyway
1/2"	.125 x .062
5/8"	.188 x .093
3/4"	.188 x .093

## Technical Data and Torque (In. Lb.)

Model No.	Wt. Lbs.	Static Torque in. lb.	Max. Speed RPM	Coil Voltage vdc	* Rated Current amps	RPM									
						0	300	600	900	1200	1500	1800	2400	3000	3600
303	.71	60	3600	90	.11	60	53	48	43	42	41	38	35	32	30

\* Rated current for 90v.

Customer must maintain:

1. Concentricity between mounting flange and shaft within .006.
2. Perpendicularity between mounting surface and shaft within .006.

Refer to Section M for torque and heat dissipation curves.

## Order Parts for Assembly No. FC303055

	Armature Plate	Magnet Accessory	Armature Hub Assembly			Magnet
			Bore			
			1/2"	5/8"	3/4"	
24 Volts	303390-2	326147	303451-3	303451-5	303453-8	303353
90 Volts	303390-2	326147	303451-3	303451-5	303453-8	303354

To order, specify: 1, Armature Plate  
1, Magnet Accessory  
1, Armature Hub Assembly of required Bore size  
1, Magnet of required Voltage

For controls, see Section K.

Sold & Serviced By:  
**ELECTROMATE**  
Toll Free Phone (877) SERV098  
Toll Free Fax (877) SERV099  
www.electromate.com  
sales@electromate.com

# Flange Mounted Brake – Replacement Parts

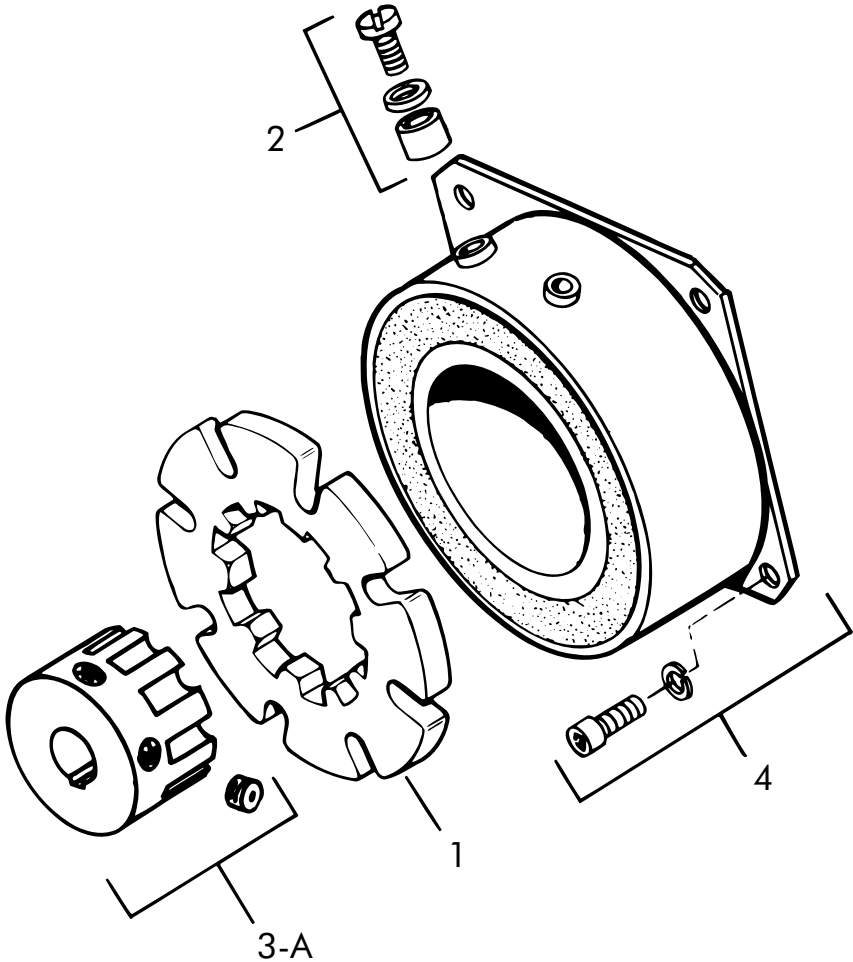

### Replacement Parts

Item	Qty.	Description	Part No.	Item	Qty.	Description	Part No.
1	1	Armature Plate Assy. (10 Teeth)	303390-2	4	1	Magnet	
2	1	Magnet Accessory	326147			24 Volts	303353
3-A	1	Armature Hub Assembly				90 Volts	303354
		3/8" Plain Bore	303453-PB				
		1/2" Bore	303451-3				
		5/8" Bore	303451-5				
		3/4" Bore	303453-8				