

Clutch Coupling

Model

● 310

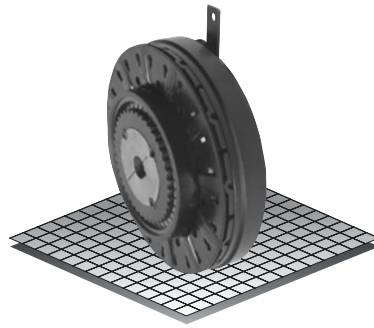

- ▶ Stationary Field
- ▶ Bearing Mounted
- ▶ Spline Drive

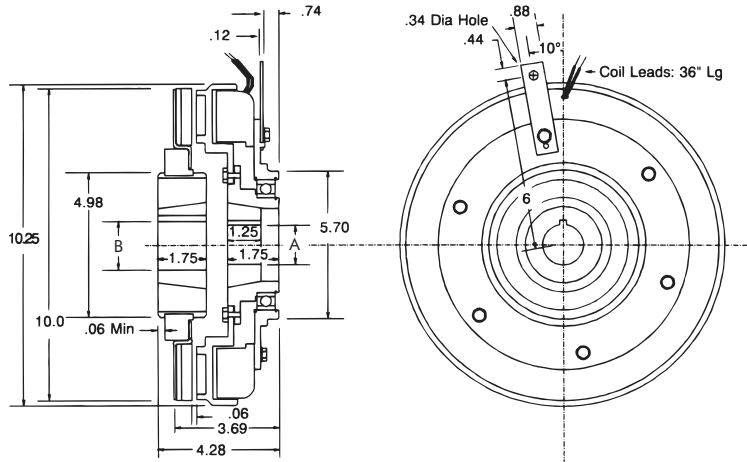

Bushing 2517

Bore "B"	Keyway	Part No.
1/2"	.500 .125 x .062	326039 - 1
9/16"	.562 .125 x .062	326039 - 2
5/8"	.625 .187 x .093	326039 - 3
11/16"	.687 .187 x .093	326039 - 4
3/4"	.750 .187 x .093	326039 - 5
13/16"	.812 .187 x .093	326039 - 6
7/8"	.875 .187 x .093	326039 - 7
15/16"	.937 .250 x .125	326039 - 8
1"	1.000 .250 x .125	326039 - 9
1-1/16"	1.062 .250 x .125	326039 - 10
1-1/8"	1.125 .250 x .125	326039 - 11
1-3/16"	1.187 .250 x .125	326039 - 12
1-1/4"	1.250 .250 x .125	326039 - 13
1-5/16"	1.312 .312 x .156	326039 - 14
1-3/8"	1.375 .312 x .156	326039 - 15
1-7/16"	1.437 .375 x .187	326039 - 16
1-1/2"	1.500 .375 x .187	326039 - 17
1-9/16"	1.562 .375 x .187	326039 - 18
1-5/8"	1.625 .375 x .187	326039 - 19
1-11/16"	1.687 .375 x .187	326039 - 20
1-3/4"	1.750 .375 x .187	326039 - 21
1-13/16"	1.812 .500 x .250	326039 - 22
1-7/8"	1.875 .500 x .250	326039 - 23
1-15/16"	1.937 .500 x .250	326039 - 24
2"	2.000 .500 x .250	326039 - 25
2-1/16"	2.062 .500 x .250	326039 - 26
2-1/8"	2.125 .500 x .250	326039 - 27
2-3/16"	2.187 .500 x .250	326039 - 28
2-1/4"	2.250 .500 x .250	326039 - 29
2-5/16"	2.312 .625 x .187	326039 - 30
2-3/8"	2.375 .625 x .187	326039 - 31
2-7/16"	2.437 .625 x .187	326039 - 32
2-1/2"	2.500 .625 x .187	326039 - 33

Bushing 2012

Bore "A"	Keyway	Part No.
1/2"	.500 .125 x .062	326167 - 8
9/16"	.562 .125 x .062	326167 - 9
5/8"	.625 .187 x .093	326167 - 10
11/16"	.687 .187 x .093	326167 - 11
3/4"	.750 .187 x .093	326167 - 12
13/16"	.812 .187 x .093	326167 - 13
7/8"	.875 .187 x .093	326167 - 14
15/16"	.937 .250 x .125	326167 - 15
1"	1.000 .250 x .125	326167 - 16
1-1/16"	1.062 .250 x .125	326167 - 17
1-1/8"	1.125 .250 x .125	326167 - 18
1-3/16"	1.187 .250 x .125	326167 - 19
1-1/4"	1.250 .250 x .125	326167 - 7
1-5/16"	1.312 .312 x .156	326167 - 20
1-3/8"	1.375 .312 x .156	326167 - 6
1-7/16"	1.437 .375 x .187	326167 - 21
1-1/2"	1.500 .375 x .187	326167 - 1
1-9/16"	1.562 .375 x .187	326167 - 22
1-5/8"	1.625 .375 x .187	326167 - 2
1-11/16"	1.687 .375 x .187	326167 - 23
1-3/4"	1.750 .375 x .187	326167 - 3
1-13/16"	1.812 .500 x .250	326167 - 24
1-7/8"	1.875 .500 x .250	326167 - 4
1-15/16"	1.937 .500 x .187	326167 - 25
2"	2.000 .500 x .187	326167 - 5

Technical Data and Torque (In. Lb.)

Model No.	Wt. Lbs.	Static Torque in. lb.	Max. Speed RPM	Coil Voltage vdc	* Rated Current amps	RPM							
						0	300	600	900	1200	1500	1800	2400
310	28	3600	2400	90	.59	3600	3144	2616	2088	1788	1596	1416	1044

* Rated Current for 90v.

Refer to Section M for torque and heat dissipation curves. Customer must maintain concentricity between shafts within .010.

Order Parts for Assembly No. FC310158

	Armature Hub	Armature Plate Assembly	(2517) Taper Bushing	Bearing Mounted Rotor & Field	(2012) Taper Bushing
24 Volts	310680	310383-13	326039-XX	310773	326167-XX
90 Volts	310680	310383-13	326039-XX	310774	326167-XX

To order, specify: 1, Armature Hub 1, Bearing Mounted Rotor and Field of required Voltage
 1, Armature Plate Assembly 1, Taper Bushing (2012) of required Bore size
 1, Taper Bushing (2517) of required Bore size

For controls, see Section K.

Sold & Serviced By:



Toll Free Phone (877) SERV098
 Toll Free Fax (877) SERV099
www.electromate.com
sales@electromate.com

Clutch Coupling – Replacement Parts

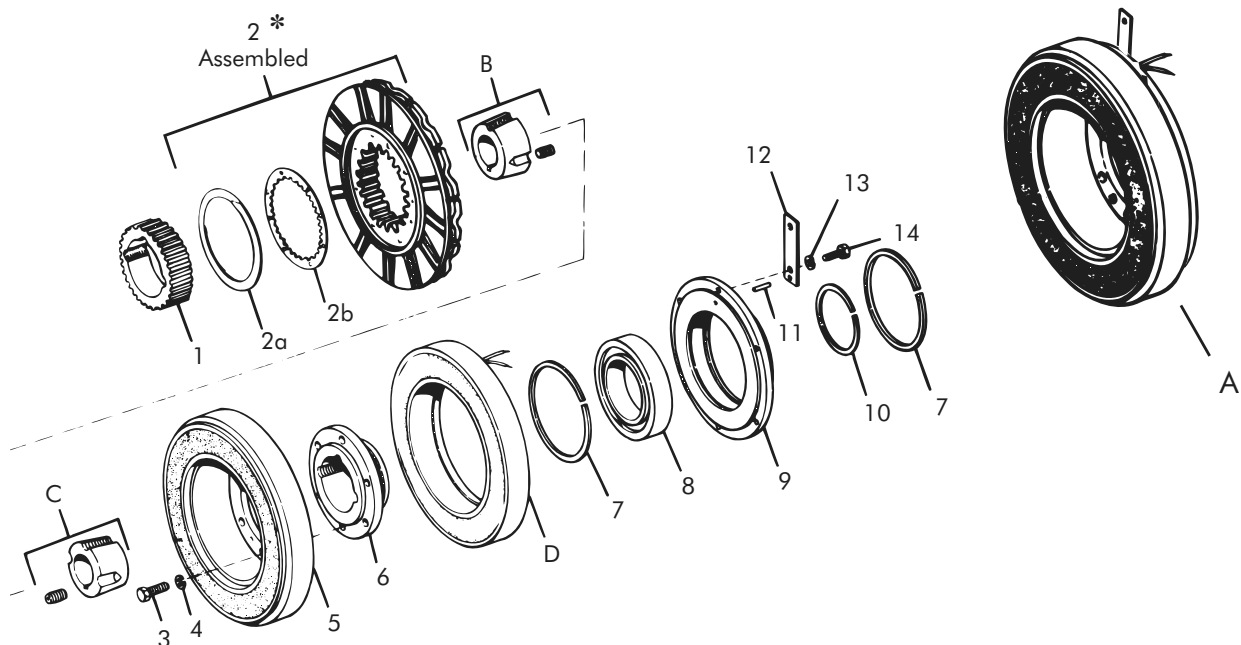

Replacement Parts

Item	Qty.	Description	Part No.	Item	Qty.	Description	Part No.
1	1	Armature Hub	310680	14	6	Screw	DY-14764
2	1	Armature Plate Assy. (39 Teeth)	310383-13	A	1	Bearing Mounted Rotor and Field	
2a	1	Adjusto-gap® Spring	326970			24 Volts	310773
2b	3	Drag Spring	326277			90 Volts	310774
3	6	Hex Head Cap Screw	DY-211	B	1	Taper Bushing (2517)	326039-XX
4	6	Lock Washer	DY-18	C	1	Taper Bushing (2012)	326167-XX
5	1	Rotor Assembly	310820-2	D	1	Field	
6	1	Rotor Hub	310753			24 Volts	310733-3
7	2	Retaining Ring (Internal)	DY-11574			90 Volts	310734-3
8	1	Bearing	DY-15269				
9	1	Field Mounting Hub	310752-1				
10	1	Retaining Ring (External)	DY-15270				
11	1	Roll Pin	DY-13213				
12	1	Support Arm	326549				
13	6	Lock Washer	DY-4366				

* Current design armatures are solid.