

# Clutch

Model

● 310

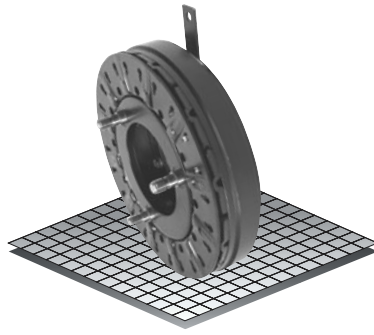

- ▶ Stationary Field
- ▶ Bearing Mounted
- ▶ Pin Drive

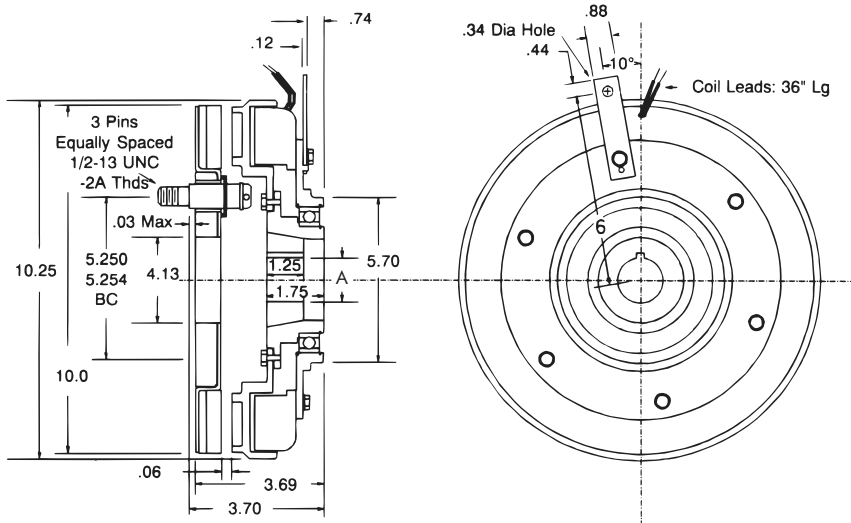

### Bushing 2012

Bore "A"	Keyway	Part No.
1/2"	.500 .125 x .062	326167 - 8
9/16"	.562 .125 x .062	326167 - 9
5/8"	.625 .187 x .093	326167 - 10
11/16"	.687 .187 x .093	326167 - 11
3/4"	.750 .187 x .093	326167 - 12
13/16"	.812 .187 x .093	326167 - 13
7/8"	.875 .187 x .093	326167 - 14
15/16"	.937 .250 x .125	326167 - 15
1"	1.000 .250 x .125	326167 - 16
1-1/16"	1.062 .250 x .125	326167 - 17
1-1/8"	1.125 .250 x .125	326167 - 18
1-3/16"	1.187 .250 x .125	326167 - 19
1-1/4"	1.250 .250 x .125	326167 - 7
1-5/16"	1.312 .312 x .156	326167 - 20
1-3/8"	1.375 .312 x .156	326167 - 6
1-7/16"	1.437 .375 x .187	326167 - 21
1-1/2"	1.500 .375 x .187	326167 - 1
1-9/16"	1.562 .375 x .187	326167 - 22
1-5/8"	1.625 .375 x .187	326167 - 2
1-11/16"	1.687 .375 x .187	326167 - 23
1-3/4"	1.750 .375 x .187	326167 - 3
1-13/16"	1.812 .500 x .250	326167 - 24
1-7/8"	1.875 .500 x .250	326167 - 4
1-15/16"	1.937 .500 x .187	326167 - 25
2"	2.000 .500 x .187	326167 - 5

### Technical Data and Torque (In. Lb.)

Model No.	Wt. Lbs.	Static Torque in. lb.	Max. Speed RPM	Coil Voltage vdc	* Rated Current amps	RPM							
						0	300	600	900	1200	1500	1800	2400
310	29.4	3600	2400	90	.59	3600	3144	2616	2088	1788	1596	1416	1044

\* Rated Current for 90v.

Refer to Section M for torque and heat dissipation curves.

### Order Parts for Assembly No. FC310152

	Armature Plate Assembly	Bearing Mounted Rotor & Field	(2012) Taper Bushing	Ajusto-gap® Accessory
24 Volts	310380	310773	326167-XX	326075
90 Volts	310380	310774	326167-XX	326075

To order, specify: 1, Armature Plate Assembly 1, Taper Bushing (2012) of required Bore size  
 1, Bearing Mounted Rotor and Field of required Voltage 1, Ajusto-gap® Accessory

For controls, see Section K.

Sold & Serviced By:  
**ELECTROMATE**  
 Toll Free Phone (877) SERV098  
 Toll Free Fax (877) SERV099  
[www.electromate.com](http://www.electromate.com)  
[sales@electromate.com](mailto:sales@electromate.com)

# Clutch – Replacement Parts

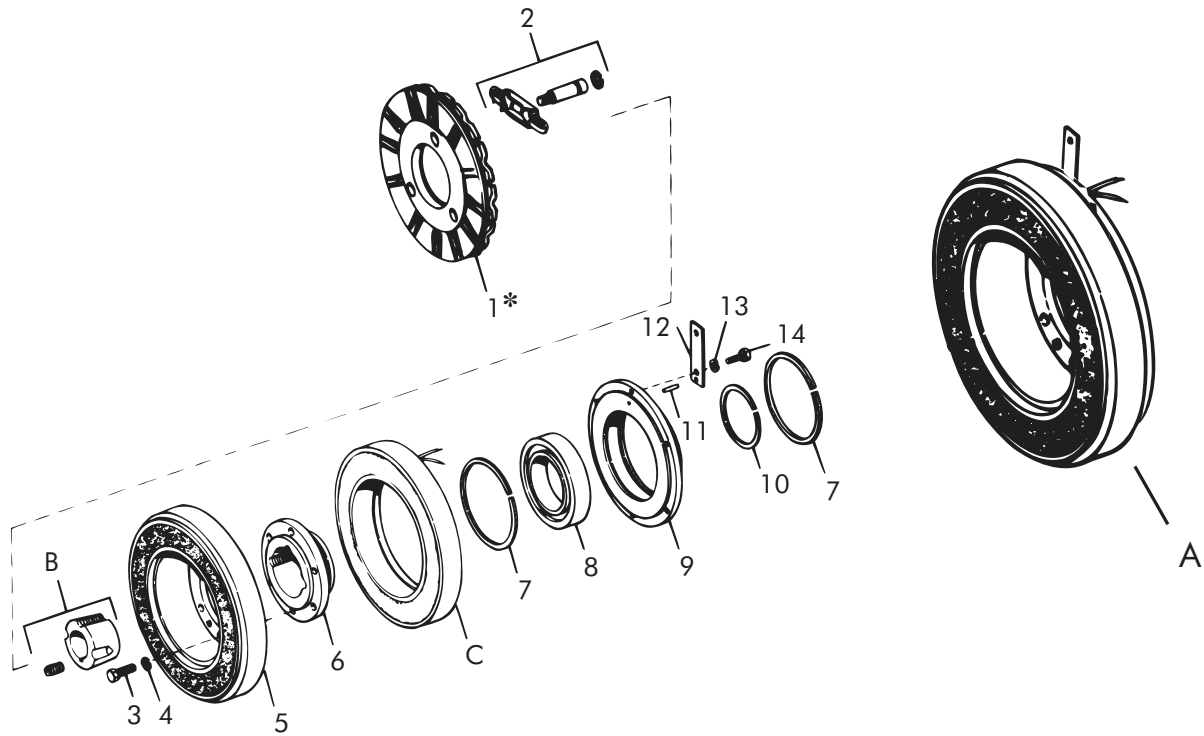

## Replacement Parts

Item	Qty.	Description	Part No.	Item	Qty.	Description	Part No.
1	1	Armature Plate Assembly	310380	13	6	Lock Washer	DY-4366
2	1	Ajusto-gap® Accessory	326075	14	6	Screw	DY-14764
2a	3	Drive Pin	326008	A	1	Bearing Mounted Rotor and Field	
2b	3	Spring	326149			24 Volts	310773
2c	3	Retaining Ring	DY-10572			90 Volts	310774
3	6	Screw	DY-211	B	1	Taper Bushing (2012)	326167-XX
4	6	Lock Washer	DY-18	C	1	Field	
5	1	Rotor Assembly	310820-2			24 Volts	310733-3
6	1	Rotor Hub	310753			90 Volts	310734-3
7	2	Retaining Ring (Internal)	DY-11574				
8	1	Bearing	DY-15269				
9	1	Field Mounting Hub	310752-1				
10	1	Retaining Ring (External)	DY-15270				
11	1	Roll Pin	DY-13213				
12	1	Support Arm	326549				

\* Current design armatures are solid.