

HarmonicDrive®

Ultra Lightweight, Flat CSF-ULW Series

5 Sizes Available



New gear units from Harmonic Drive achieve unprecedented low weight in an ultra-flat housing.

Introducing CSF-ULW ultra-lightweight gearhead. This series features a newly engineered lightweight structure with an ultra-compact shape. The ULW line maintains the same performance standards as the CSF-2UH Series. Ideal for use on end-of-arm axes for small industrial and collaborative robots, the CSF-ULW is also well suited for general industrial machinery where weight is a critical factor.

Features

Available in 5 sizes

Mass Comparison

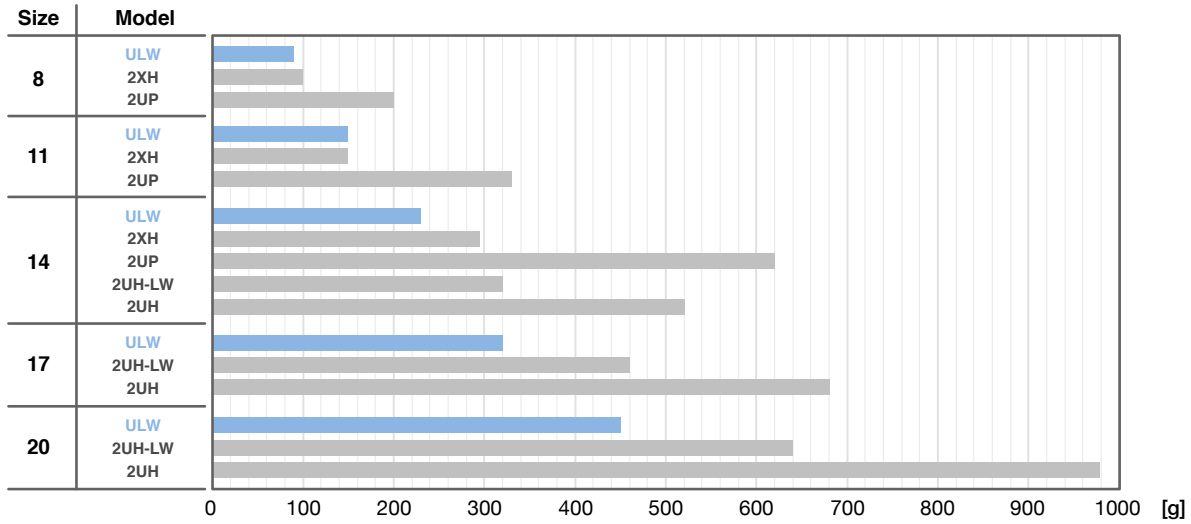

Length Comparison

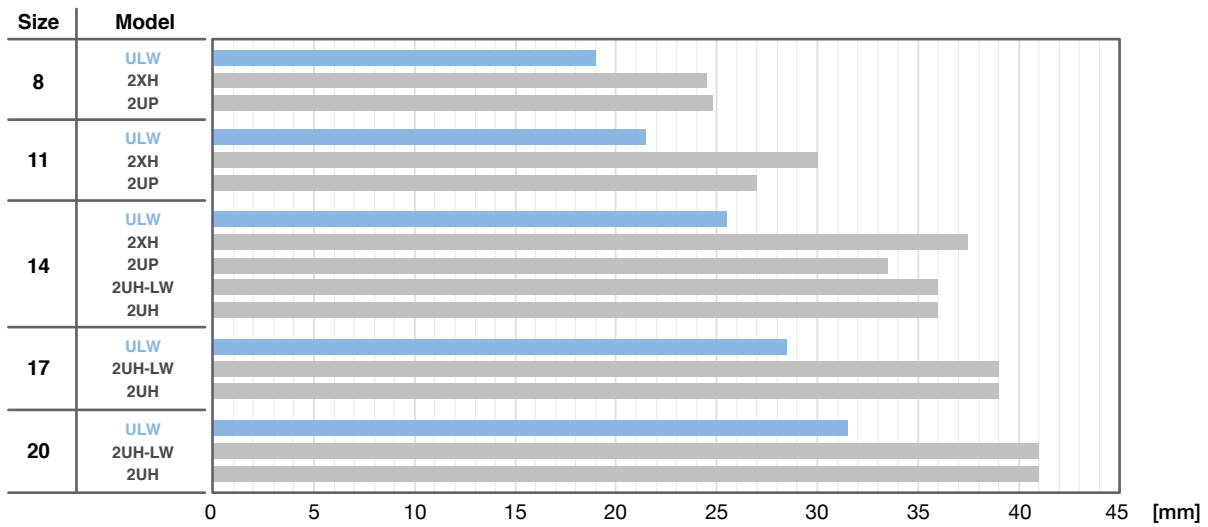

Allowable Moment Load Comparison

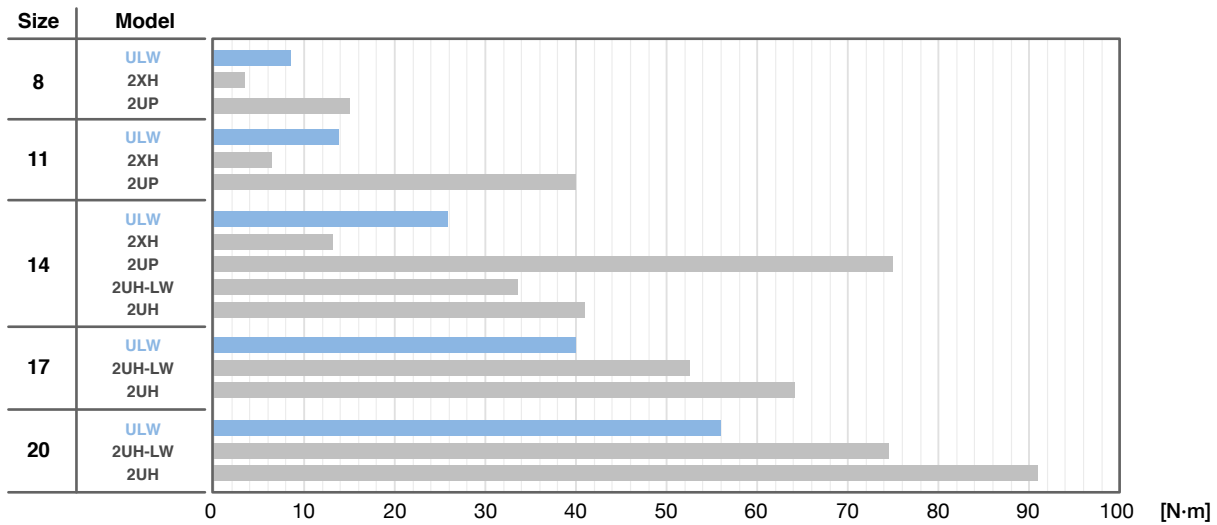

Ordering Code

CSF - 8 - 50 - 2UH - ULW - Specifications

Model	Size	Reduction Ratio						Type	Specification 1	Special Specifications
CSF Series	8	30	50	-	100	-	-	2UH: Unit	ULW: Ultra-lightweight	Blank = Standard product SP = Special specification code
	11	30	50	-	100	-	-			
	14	-	50	80	100	-	-			
	17	-	50	80	100	120	-			
	20	-	50	80	100	120	160			

Rating Table

Size	Reduction Ratio	Rated Torque at input Speed 2000 rpm	Limit for Repeated Peak Torque	Limit for Average Torque	Limit for Momentary Peak Torque	Allowable Maximum Input Speed	Allowable Average Input Speed	Moment of Inertia (1/4GD ²)
		N-m	N-m	N-m	N-m	rpm	rpm	kg-m ²
8	30	0.9	1.8	1.4	3.3	8500	3500	1.7×10 ⁻⁷
	50	1.8	3.3	2.3	6.6			
	100	2.4	4.8	3.3	9.0			
11	30	2.2	4.5	3.4	8.5	8500	3500	8.6×10 ⁻⁷
	50	3.5	8.3	5.5	17			
	100	5.0	11	8.9	25			
14	50	5.4	18	6.9	35	8500	3500	2.2×10 ⁻⁶
	80	7.8	23	11	47			
	100	7.8	28	11	54			
17	50	16	34	26	70	7300	3500	5.5×10 ⁻⁶
	80	22	43	27	87			
	100	24	54	39	108			
	120	24	54	39	86			
20	50	25	56	34	98	6500	3500	1.1×10 ⁻⁵
	80	34	74	47	127			
	100	40	82	49	147			
	120	40	87	49	147			
	160	40	92	49	147			

Sold & Serviced By:



Toll Free Phone (877) SERV098
www.electromate.com
sales@electromate.com

Outline Drawing

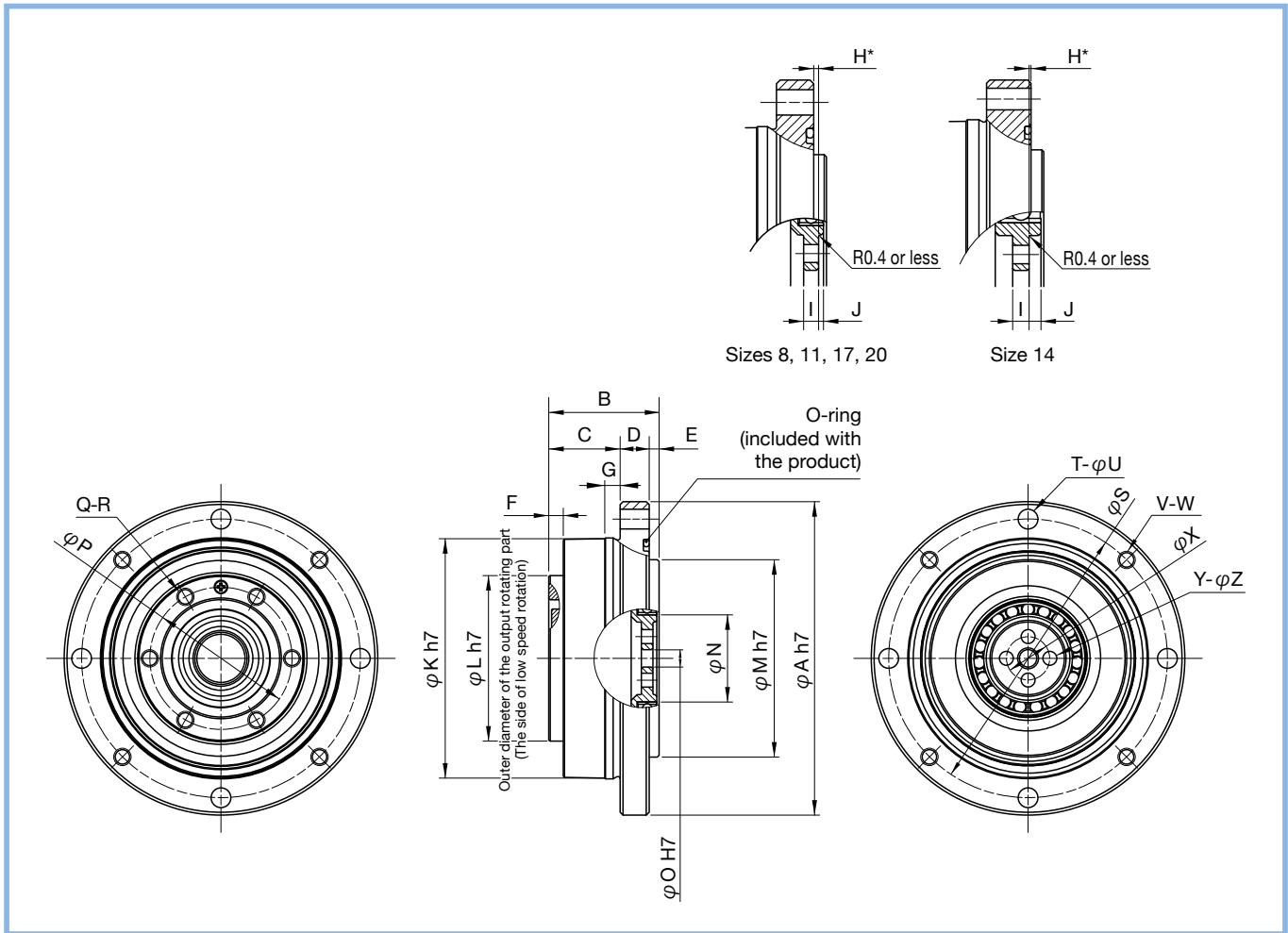

Dimension Table

[Unit: mm]

Size	Symbol	$\phi A h7$	B	C	D	E	F	G	H^*	I	J	$\phi K h7$	$\phi L h7$	$\phi M h7$	ϕN
8		54	19.0	12.3	5.0	1.7	2.5	2.5	$0.65_{-0.3}^0$	2.0	0.7	41.5	28.5	34	12.5
11		63	21.5	13.0	6.5	2.0	2.5	3.3	$0.35_{-0.7}^0$	2.4	1.3	50.5	36.5	42	18.2
14		71	25.5	16.5	7.0	2.0	2.5	3.0	$0.30_{-0.8}^{+0.8}$	2.6	1.88	58.5	43.5	49	22.0
17		81	28.5	18.0	8.0	2.5	2.5	3.0	$0.20_{-0.9}^0$	2.7	2.0	67.5	52.0	57	26.5
20		93	31.5	20.5	8.0	3.0	2.5	3.0	$0.30_{-1.0}^0$	3.1	2.6	77.0	60.5	63	31.5

Size	Symbol	$\phi O H7$	ϕP	Q	R	ϕS	T	U	V	W	X	Y	Z	Weight (g)
8		3	24.5	6	M3×4.0	48.0	4	3.4	4	M3	7.5	4	2.4	90
11		7	32.0	8	M3×4.5	57.0	4	3.4	4	M3	12.0	4	2.9	150
14		11	39.0	10	M3×4.5	65.0	6	3.4	6	M3	16.0	4	2.9	230
17		13	47.5	16	M3×4.5	74.5	10	3.4	10	M3	19.5	4	3.4	320
20		19	56.0	18	M3×4.5	84.5	12	3.4	12	M3	25.5	4	3.4	450

* Dimension H is the mounting position in the shaft direction and tolerance of the three parts (wave generator, flexspline, circular spline). Strictly observe these dimensions as they affect the performance and strength.

Positional Accuracy

Reduction Ratio		Size	8	11	14	17	20
30	×10 ⁻⁴ rad		5.8	5.8	-	-	-
	arc-min		2.0	2.0	-	-	-
50 or higher	×10 ⁻⁴ rad		5.8	4.4	4.4	4.4	2.9
	arc-min		2.0	1.5	1.5	1.5	1.0

Hysteresis Loss

Reduction Ratio		Size	8	11	14	17	20
30	×10 ⁻⁴ rad		8.7	8.7	-	-	-
	arc-min		3.0	3.0	-	-	-
50	×10 ⁻⁴ rad		5.8	5.8	5.8	5.8	5.8
	arc-min		2.0	2.0	2.0	2.0	2.0
80 or higher	×10 ⁻⁴ rad		5.8	5.8	2.9	2.9	2.9
	arc-min		2.0	2.0	1.0	1.0	1.0

Torsional Stiffness

		Size	8	11	14	17	20	
T1	N·m		0.29	0.8	2.0	3.9	7.0	
	kgf·m		0.03	0.082	0.2	0.4	0.7	
T2	N·m		0.75	2.0	6.9	12.0	25.0	
	kgf·m		0.077	0.2	0.7	1.2	2.5	
Reduction Ratio 30	K1	×10 ⁴ N·m/rad	0.034	0.084	-	-	-	
		kgf·m/arc-min	0.010	0.025	-	-	-	
	K2	×10 ⁴ N·m/rad	0.044	0.130	-	-	-	
		kgf·m/arc-min	0.013	0.037	-	-	-	
	K3	×10 ⁴ N·m/rad	0.054	0.160	-	-	-	
		kgf·m/arc-min	0.016	0.047	-	-	-	
θ1	×10 ⁻⁴ rad		8.5	9.5	-	-	-	
	arc-min		3.0	3.3	-	-	-	
θ2	×10 ⁻⁴ rad		19	19	-	-	-	
	arc-min		6.6	6.5	-	-	-	
Reduction Ratio 50	K1	×10 ⁴ N·m/rad	0.044	0.22	0.34	0.81	1.3	
		kgf·m/arc-min	0.013	0.066	0.1	0.24	0.38	
	K2	×10 ⁴ N·m/rad	0.067	0.30	0.47	1.1	1.8	
		kgf·m/arc-min	0.02	0.09	0.14	0.32	0.52	
	K3	×10 ⁴ N·m/rad	0.084	0.32	0.57	1.3	2.3	
		kgf·m/arc-min	0.025	0.096	0.17	0.4	0.67	
	θ1	×10 ⁻⁴ rad		6.6	3.6	5.8	4.9	5.2
		arc-min		2.3	1.2	2.0	1.7	1.8
	θ2	×10 ⁻⁴ rad		13	8	16	12	15.4
		arc-min		4.7	2.6	5.6	4.2	5.3
	Reduction Ratio 80 or higher	K1	×10 ⁴ N·m/rad	0.091	0.27	0.47	1	1.6
			kgf·m/arc-min	0.027	0.08	0.14	0.3	0.47
K2		×10 ⁴ N·m/rad	0.1	0.34	0.61	1.4	2.5	
		kgf·m/arc-min	0.031	0.10	0.18	0.4	0.75	
K3		×10 ⁴ N·m/rad	0.12	0.44	0.71	1.6	2.9	
		kgf·m/arc-min	0.036	0.13	0.21	0.46	0.85	
θ1		×10 ⁻⁴ rad		3.2	3.0	4.1	3.9	4.4
		arc-min		1.1	1.0	1.4	1.3	1.5
θ2		×10 ⁻⁴ rad		8.0	6.0	12	9.7	11.3
		arc-min		2.6	2.2	4.2	3.3	3.9

* This table shows the reference values. The lower limit value is approximately 80% of the displayed value.

Sold & Serviced By:



Toll Free Phone (877) SERV098

www.electromate.com

sales@electromate.com

* For details of terms, refer to the *Engineering Data* in the *Harmonic Drive® Reducer Catalog*.

Starting Torque

(Unit: Ncm)

Reduction Ratio \ Size	8	11	14	17	20
30	1.5	3	-	-	-
50	0.9	1.8	3.6	5.5	7.2
80	-	-	2.6	3.6	4.5
100	0.7	1.2	2.3	3.1	4.0
120	-	-	-	2.9	3.6
160	-	-	-	-	3.1

Backdriving Torque

(Unit: N·m)

Reduction Ratio \ Size	8	11	14	17	20
30	0.7	1.4	-	-	-
50	0.55	1.1	1.6	2.7	4.3
80	-	-	1.6	2.7	4.5
100	0.75	1.5	1.9	3.0	4.8
120	-	-	-	3.3	5.2
160	-	-	-	-	6.1

Buckling Torque

(Unit: N·m)

Reduction Ratio \ Size	8	11	14	17	20
Total Reduction Ratio	35	90	190	330	510

Sold & Serviced By:



Toll Free Phone (877) SERV098

www.electromate.com

sales@electromate.com

No-Load Running Torque

No-load running torque is the input torque (high-speed shaft side) required to rotate a Harmonic Drive® gear under a no-load condition.

* Contact us for details.

Measuring Condition

Lubrication	Size 8, 11, 14, 17	Size 20	Main Bearing
	Harmonic Grease® SK-2	Harmonic Grease® SK -1A	Multemp HL-D*

The torque value is measured after two or more hours run-in at 2000 rpm input speed.

* "Multemp" is a registered trademark of Kyodo Yushi Co., Ltd.

Compensation Value

(Unit: Ncm)

Reduction Ratio \ Size	8	11	14	17	20
30	0.54	1.05	-	-	-
50	0.23	0.43	0.63	1.01	1.54
80	-	-	0.11	0.17	0.27
120	-	-	-	-0.13	-0.19
160	-	-	-	-	-0.45

* The efficiency compensation amount of size 8, 11 is the average value when the grease temperature is approximately 30°C.

No-Load Running Torque (Ratio100:1)

Input rotational speed 500rpm

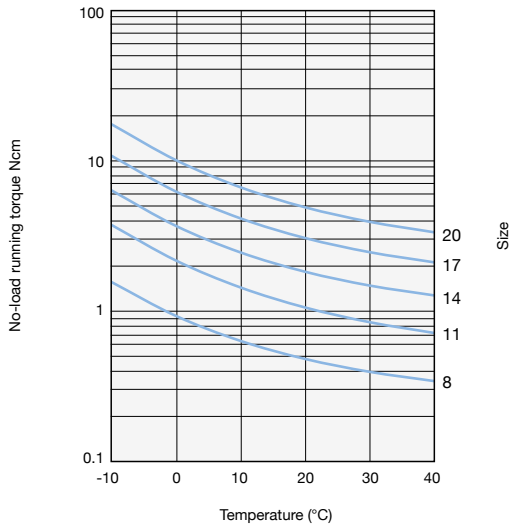

Input rotational speed 1000rpm

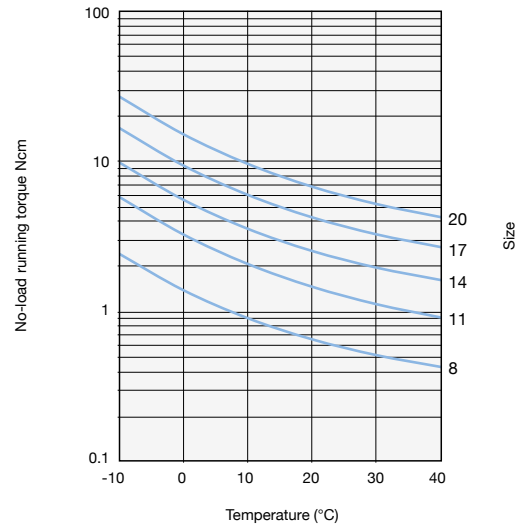

Input rotational speed 2000rpm

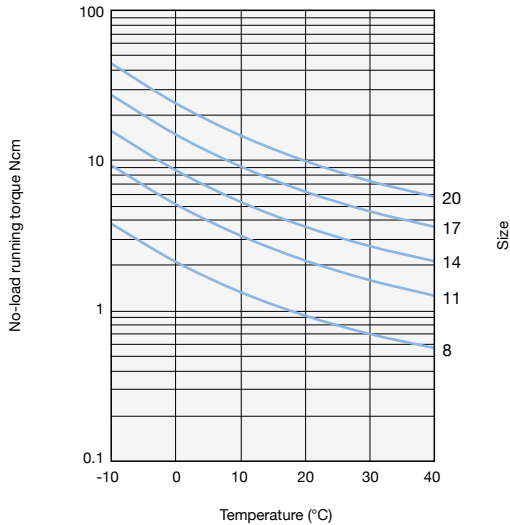

Input rotational speed 3500rpm

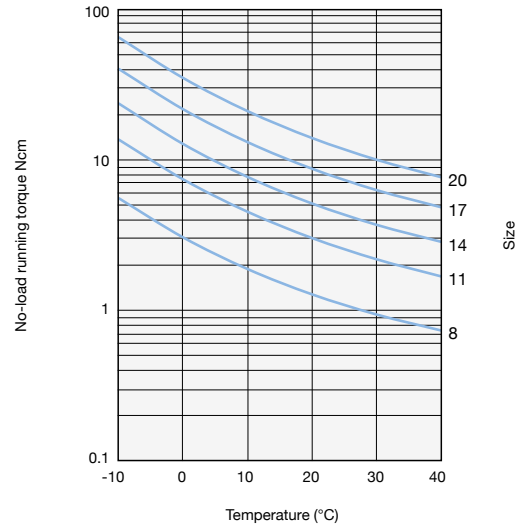

* The graphs show the average value X.

Efficiency

The efficiency is varied depending on the load torque. Obtain efficiency compensation coefficient K_e from the graph, and check the value through the following formula.

*1 The efficiency compensation coefficient is the average value when the grease temperature is approximately 30°C.

*2 When load torque is larger than rated torque, efficiency compensation coefficient is $K_e = 1$.

Efficiency compensation coefficient: K_e

Efficiency at rated torque: η_R

Efficiency depending on the load torque: η

$$\eta = K_e \times \eta_R$$

Measuring Condition

Lubrication	Size 8, 11, 14, 17	Size 20	Main Bearing
	Harmonic Grease® SK-2	Harmonic Grease® SK -1A	Multemp HL-D*

The torque value is measured after two or more hours run-in at 2000 rpm input speed.

* "Multemp" is a registered trademark of Kyodo Yushi Co., Ltd.

Efficiency Compensation Coefficient

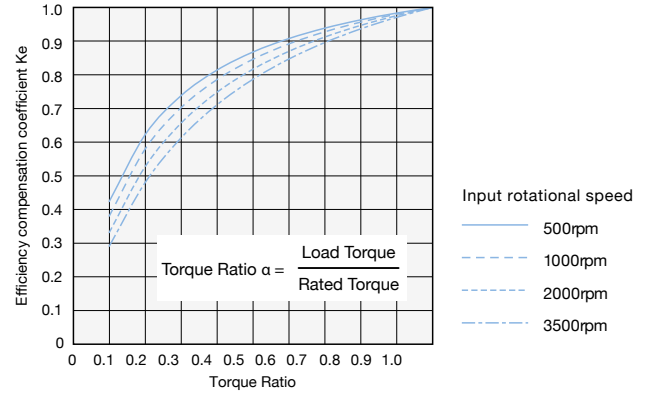

Efficiency at Rated Torque

Size 8

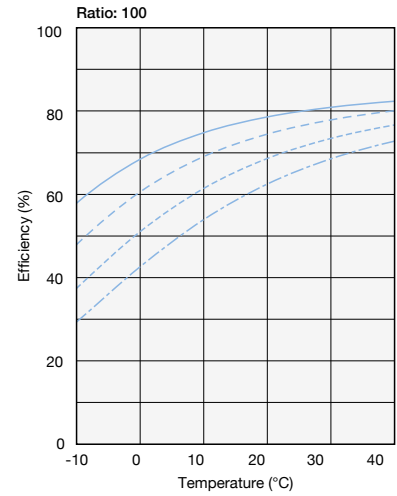
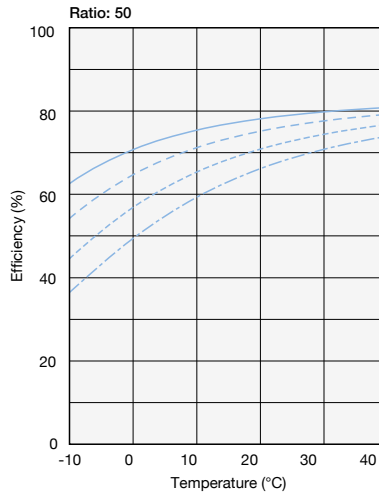
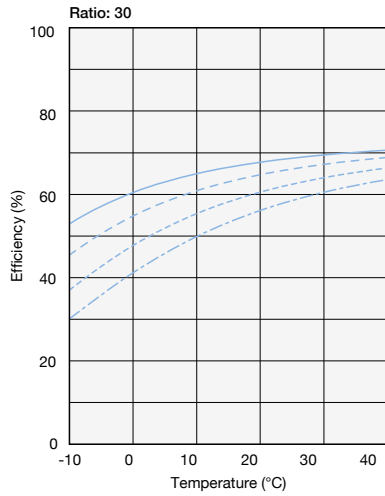

Size 11

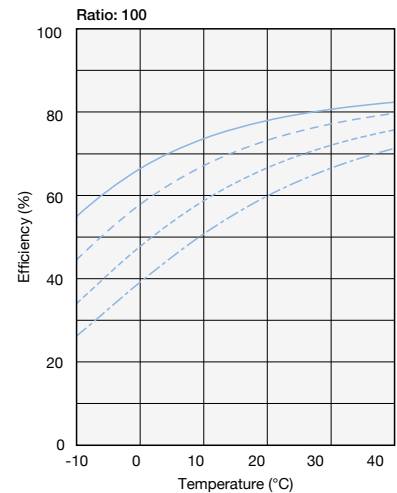
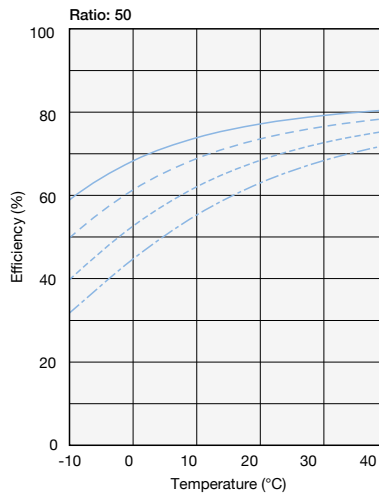
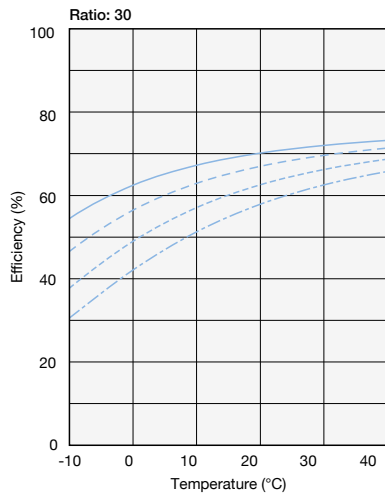

* The graphs show the average value X.

Size 14

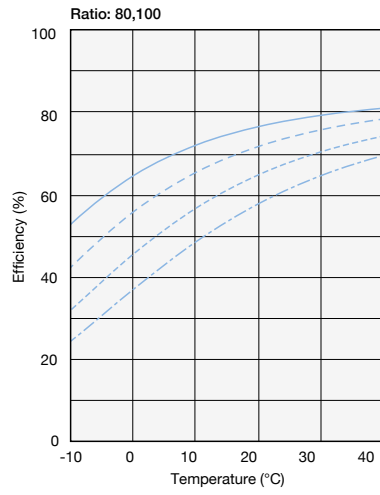
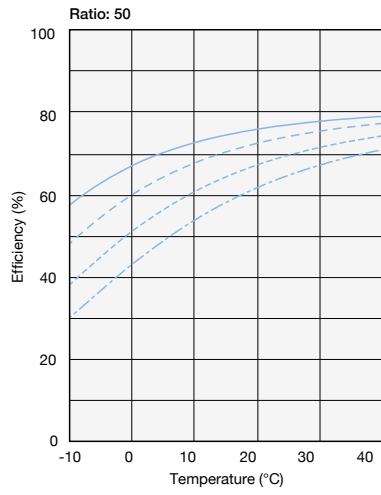

Size 17

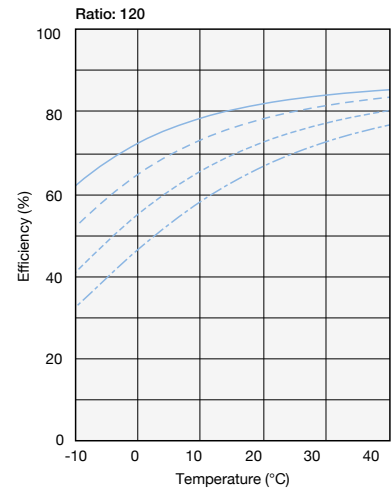
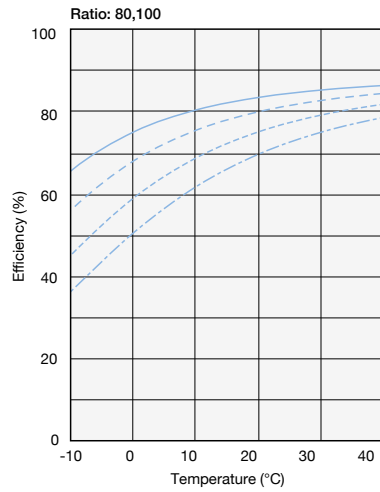
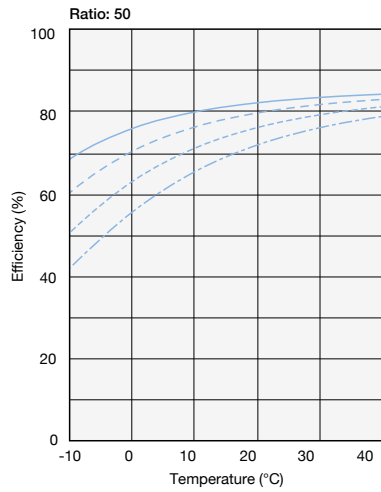

* The graphs show the average value X.

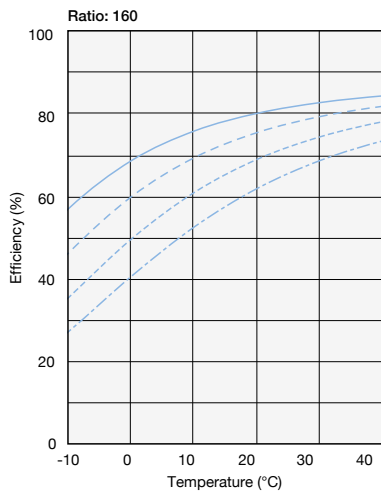
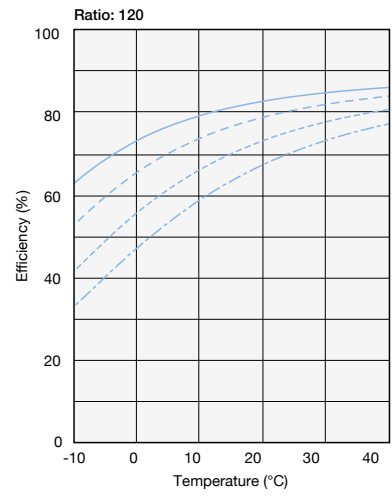
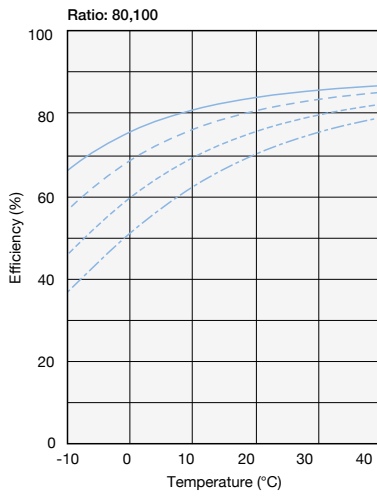
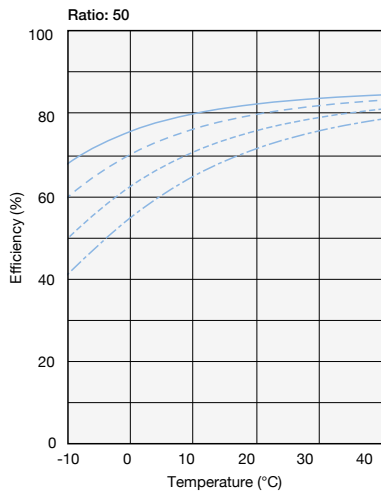

* The graphs show the average value X.

Specifications of the Main Bearing

The CSF-ULW Series incorporates a small 4-point contact ball bearing to directly support the external load (output part). Please check the maximum moment load, the life of the small 4-point contact ball bearing and the static safety coefficient to fully exert the performance of the CSF-ULW Series.

Checking Procedure

For details of the checking procedure, refer to *Checking Main Roller Bearing* in the *Engineering Data* section of the Harmonic Drive® Reducer Catalog.

(1) Checking the maximum moment load (M_{max})



(2) Checking the life

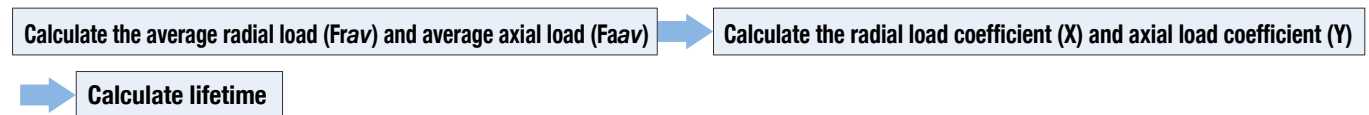

(3) Checking the static safety coefficient

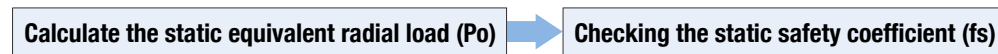

Main Bearing Specifications

Size	Pitch Circle	Offset	Basic Rated Load		Allowable Moment Load M_c	Moment Stiffness K_m
	d_p	R	Basic dynamic load rating C	Basic static load rating C_0		
	mm	mm	N	N		
8	29	7.9	1.8×10^3	2.2×10^3	8.7	1.0×10^4
11	37.1	8.15	2.8×10^3	3.5×10^3	14	1.7×10^4
14	44.3	8.4	3.9×10^3	5.0×10^3	26	3.0×10^4
17	52.7	9.2	5.2×10^3	7.0×10^3	40	4.6×10^4
20	61.4	9.7	6.7×10^3	9.4×10^3	56	6.5×10^4

* The basic dynamic load rating is a constant static radial load that provides a basic dynamic rating life of bearings to reach 1 million rotations.

* The basic static load rating is the static load that gives a certain level of contact stress (4.2kN/mm^2) at the center of the contact area between the rolling element receiving the maximum load.

* The allowable moment load is the maximum moment load that can be applied to the output shaft. Within this range, the basic performance is maintained, and the operation is possible for this value.

* Moment stiffness is a reference value, and the lower limit is approximately 80% of the displayed value. The lower limit value is approximately 80% of the displayed value.

Sold & Serviced By:



Toll Free Phone (877) SERV098

www.electromate.com

sales@electromate.com

Mechanical Accuracy

The CSF-2UH-ULW Series has four-point contact ball bearing of high accuracy on main shaft bearing and realized the high-mechanical accuracy of output part.

The mechanical accuracy of the output shaft is shown below.

Symbol	Accuracy Item	Size				
		8	11	14	17	20
a	Output shaft runout	0.010	0.010	0.010	0.010	0.010
b	Mounting pilot concentricity	0.050	0.050	0.060	0.060	0.070
c	Output flange axial surface runout	0.010	0.010	0.010	0.010	0.010
d	Parallelism between the mounting face and the output flange face	0.025	0.025	0.025	0.025	0.025

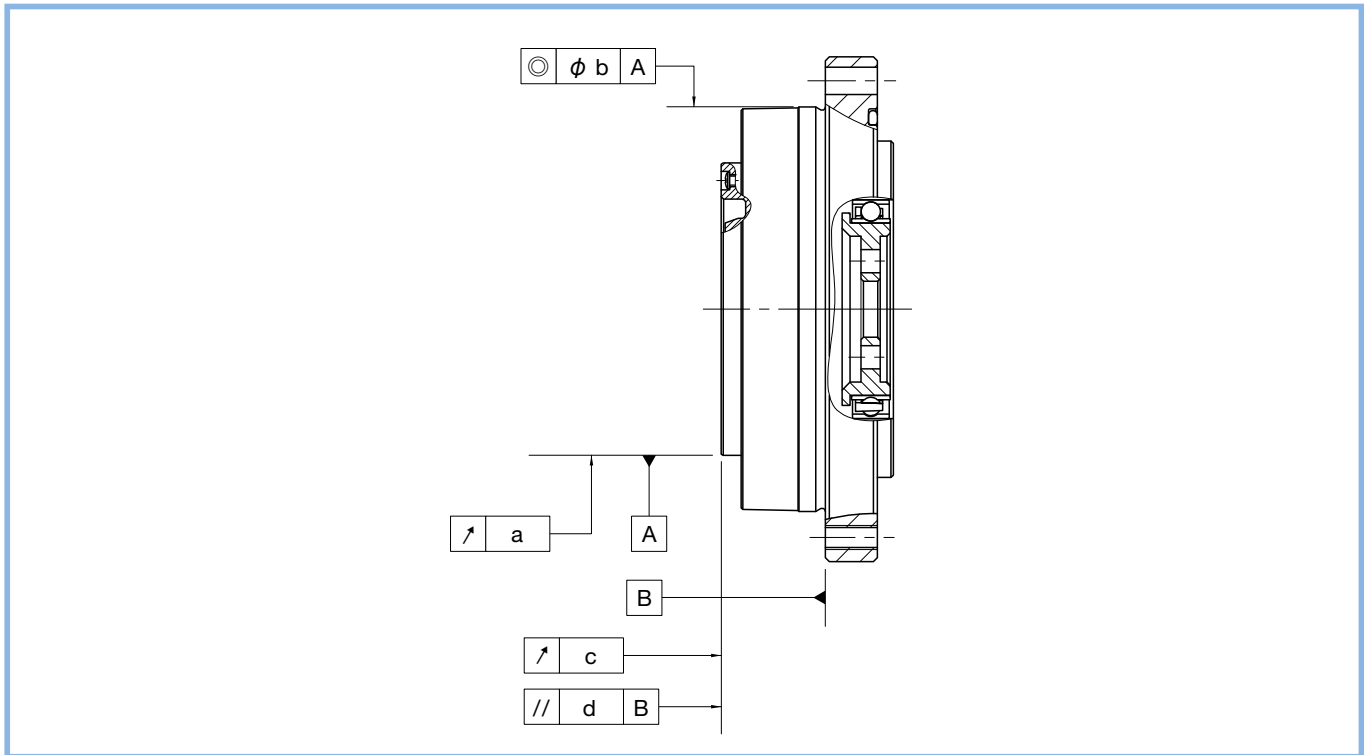

Lubrication

Grease lubrication is the standard lubrication of the CSF-2UH-ULW Series.

The product is lubricated and shipped. You do not need to apply grease.

The following grease is used as the lubrication agent:

Lubrication part	Size 8, 11, 14, 17	Size 20	Main bearing
Grease	Harmonic Grease® SK-2	Harmonic Grease® SK -1A	Multemp HL-D
Manufacturer	Harmonic Drive Systems Inc.	Harmonic Drive Systems Inc.	Kyodo Yushi Co., Ltd.
Base oil	Purified mineral oil	Purified mineral oil	Synthetic hydrocarbon oil
Thicken	Lithium soap base	Lithium soap base	Lithium soap base
Base Viscosity (25°C)	295	295	280
Drop point	198°C	197°C	210°C
Appearance	Green	Yellow	White

Installation Accuracy

For peak performance of the CSF-2UH-ULW, maintain the recommended tolerances.

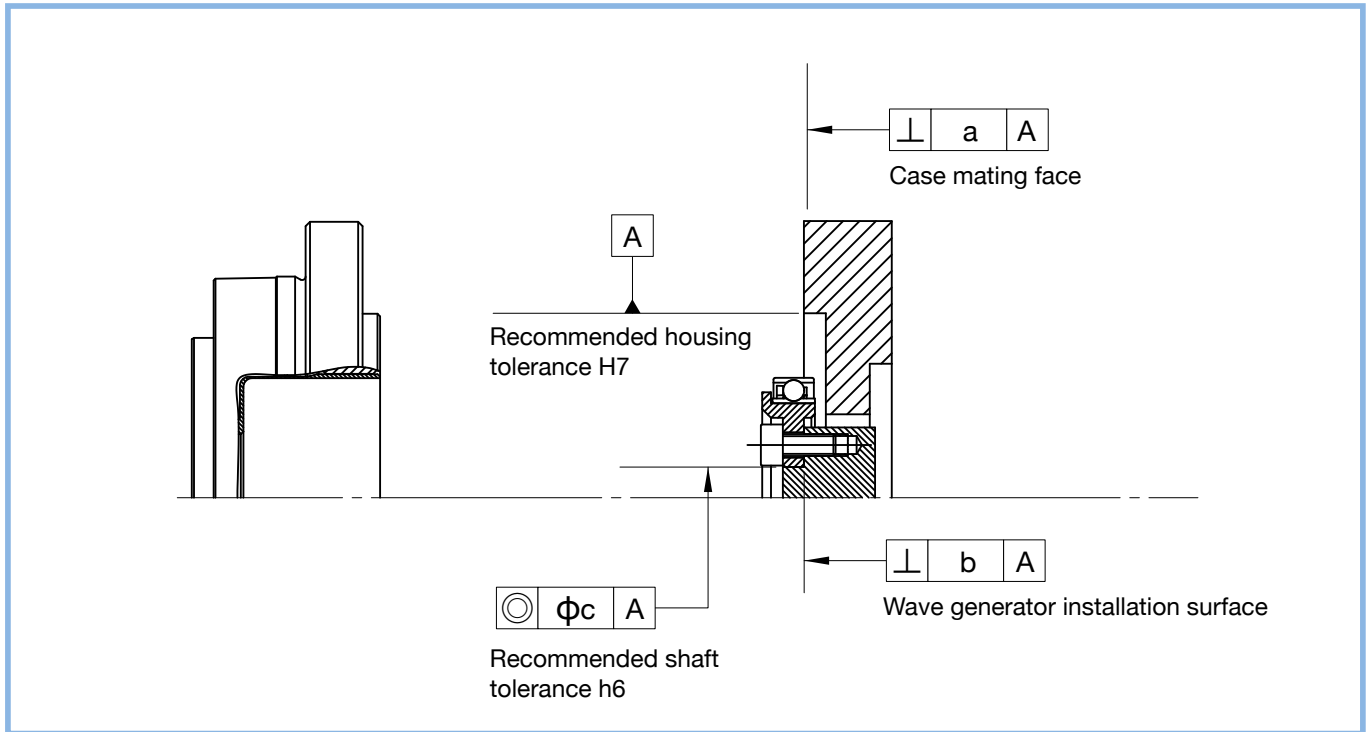

Symbol	Accuracy Item	Size				
		8	11	14	17	20
a	Perpendicularity of the case mating face	0.010	0.011	0.011	0.015	0.017
b	Perpendicularity of the wave generator	0.006	0.007	0.008	0.010	0.010
c	Concentricity of the input shaft	0.006	0.007	0.016	0.018	0.019

Sold & Serviced By:



Toll Free Phone (877) SERV098
www.electromate.com
sales@electromate.com

Installation and Transmission Torque

Precautions when installing the product

For peak performance of the gear, it is essential that the following tolerances be observed when assembly is complete. Pay careful attention to the following points:

- Warping and deformation on the mounting surface
- Contamination due to foreign matter
- Burrs, raised surfaces and location around the tap area of the mounting holes
- Insufficient chamfering on the mounting pilot joint
- Insufficient radii on the mounting pilot joint

Installation on the equipment

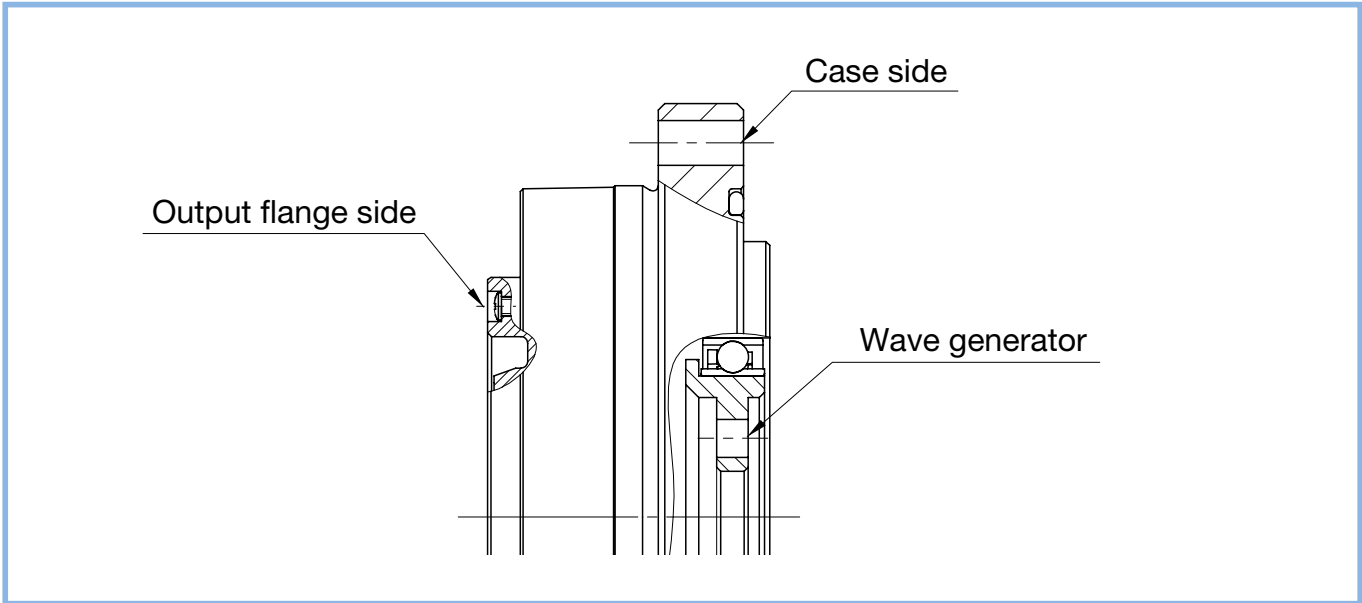

Installation and transmission torque on the output flange side

Item		Size	8	11	14	17	20
Number of bolts			6	8	10	16	18
Bolt size			M3	M3	M3	M3	M3
Mounting P.C.D	mm		24.5	32.0	39.0	47.5	56.0
	N·m		2.0	2.0	2.0	2.0	2.0
Bolt tightening torque	kgf·m		0.20	0.20	0.20	0.20	0.20
	N·m		30.6	53.3	81.2	158	210
Bolt transmission torque	kgf·m		3.12	5.43	8.28	16.1	21.4

Installation and transmission torque on case side

Item		Size	8	11	14	17	20
Number of bolts			4	4	6	10	12
Bolt size			M3	M3	M3	M3	M3
Mounting P.C.D	mm		48.0	57.0	65.0	74.5	84.5
	N·m		1.4	1.4	1.4	1.4	1.4
Bolt tightening torque	kgf·m		0.14	0.14	0.14	0.14	0.14
	N·m		28	33.2	56.8	108	147
Bolt transmission torque	kgf·m		2.85	3.38	5.79	11.0	14.9

Installation and transmission torque on wave generator side

Item		Size	8	11	14	17	20
Number of bolts			4	4	4	4	4
Bolt size			M2	M2.5	M2.5	M3	M3
Mounting P.C.D	mm		7.5	12	16	19.5	25.5
	N·m		0.54	1.08	1.08	2.0	2.0
Bolt tightening torque	kgf·m		0.055	0.110	0.110	0.20	0.20
	N·m		2.53	6.48	8.64	16.2	21.2
Bolt transmission torque	kgf·m		0.25	0.66	0.88	1.6	2.1
	N·m						

Precautions for Use

Use only in a specified environment

Ensure the following environmental conditions are complied with:

- Ambient temperature 0 to 40°C
- No splashing of water or oil
- Do not expose to corrosive or explosive gas
- No dust such as metal powder

* For other precautions, refer to the "Harmonic Drive® Reducer Catalog."

Sold & Serviced By:



Toll Free Phone (877) SERV098
www.electromate.com
sales@electromate.com

Sold & Serviced By:



ELECTROMATE

Toll Free Phone (877) SERV098

www.electromate.com

sales@electromate.com

