

Gearheads

Sold & Serviced By:



Toll Free Phone (877) SERV098
Toll Free Fax (877) SERV099
www.electromate.com
sales@electromate.com



HDI Series Infinit Indexer® Phase Adjusters

- [PDF Catalog](#)
- [CAD Downloads](#)

HDI's are Harmonic Drive shaft mounted gear reducers. They provide hand adjustable, precise, static phase adjustment. On rotating shafts the HDI functions as rigid shaft coupling. Phase adjustment is accomplished when the drive system is stopped. Adjustments are made by hand in either direction by adjusting the knurled outer ring producing infinitely variable relative rotation of the hubs through a 100:1 reduction ratio. With the "D" hub fixed, rotation of the "S" hub is opposite to the direction of nut rotation. With the "S" hub fixed, rotation at the "D" hub is in the same direction as nut rotation.

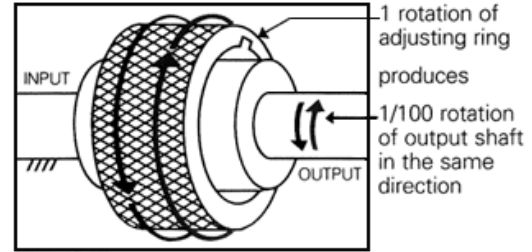

Infinit Indexers are available in 6 sizes and have torque ratings from 500-20,000 inch pounds. There are two ways to purchase HDI phase adjusters; from our stocking program or by special order from a customer request.

The Stocking Program

The stocking program offers the most cost effective way to purchase HDI phase adjusters. Three sizes of HDIs, (10, 25, and 50,) are available from the stocking program. Each comes with keyways and tapped holes on both hubs and is readily available from stock. Several bore sizes are available from the stocking program:

Dimensions are in inches

HDI Size	Bore Sizes	Keyway	Tapped Holes	Torque Capacity
10	1/2"	3/16"	#8-32	1000 lb-in 113 Nm
	5/8"			
	3/4"			
25	3/4"	1/4"	#10-32	2500 lb-in 283 Nm
	1"			
50	1 1/4"	1/4"	1/4-20	5000 lb-in 565 Nm

HDI Stocking Program

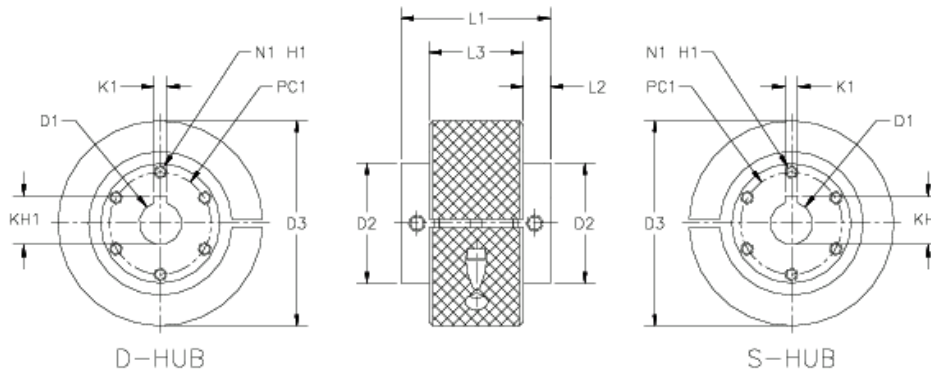

Dimensions are in inches

	Size					
	10	10	10	25	25	50
BORE	0.5000	0.6250	0.7500	0.7500	1.0000	1.2500
D2	1.38	1.38	1.38	1.75	1.75	2.17
D3	2.38	2.38	2.38	3.00	3.00	3.75

Sold & Serviced By:



Toll Free Phone (877) SERV098
Toll Free Fax (877) SERV099
www.electromate.com
sales@electromate.com

11/2/2008

Sold & Serviced By:



Toll Free Phone (877) SERV098
 Toll Free Fax (877) SERV099
 www.electromate.com
 sales@electromate.com

L1	1.69	1.69	1.69	2.19	2.19	2.37
L2	0.31	0.31	0.31	0.40	0.40	0.37
L3	1.06	1.06	1.06	1.38	1.38	1.63
K1	0.1875	0.1875	0.1875	0.2500	0.2500	0.2500
KH1	0.585	0.710	0.831	0.863	1.114	1.368
N1	3	3	3	6	6	6
H1	#8-32	#8-32	#8-32	#10-32	#10-32	1/4-20
PC1	1.125	1.125	1.125	1.500	1.500	1.750
CAD Downloads	PDF DXF		PDF DXF		PDF DXF	

HDI - 010

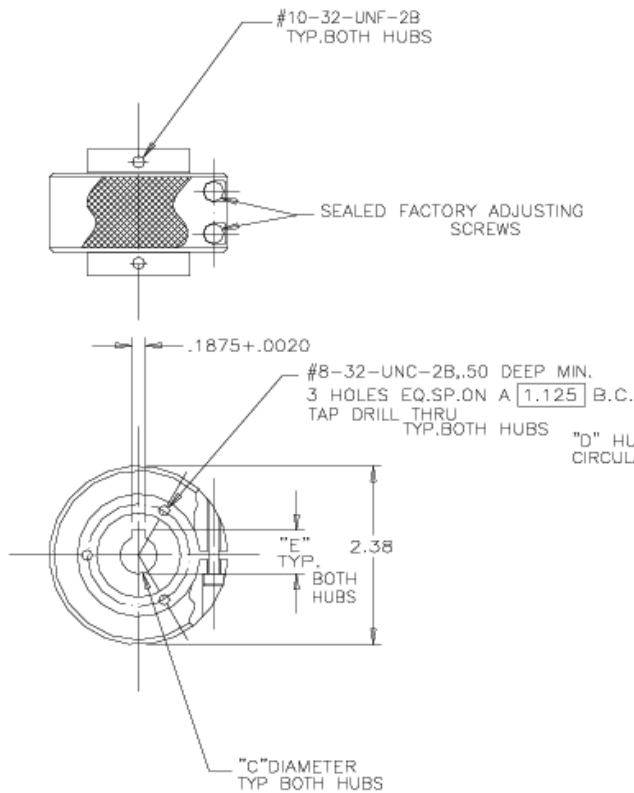

NOTE:
 Maximum Bore Diameter
 not to exceed .75 in.

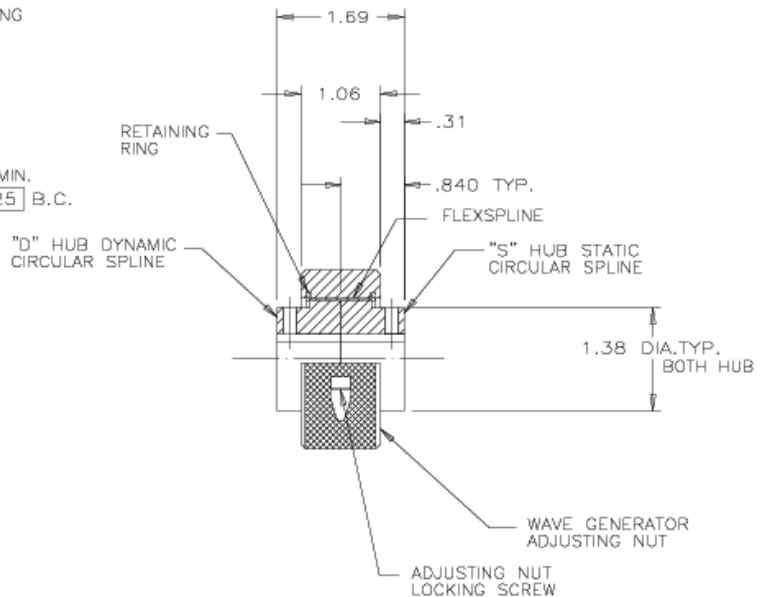

Sold & Serviced By:



Toll Free Phone (877) SERV098
 Toll Free Fax (877) SERV099
 www.electromate.com
 sales@electromate.com

HDI - 025

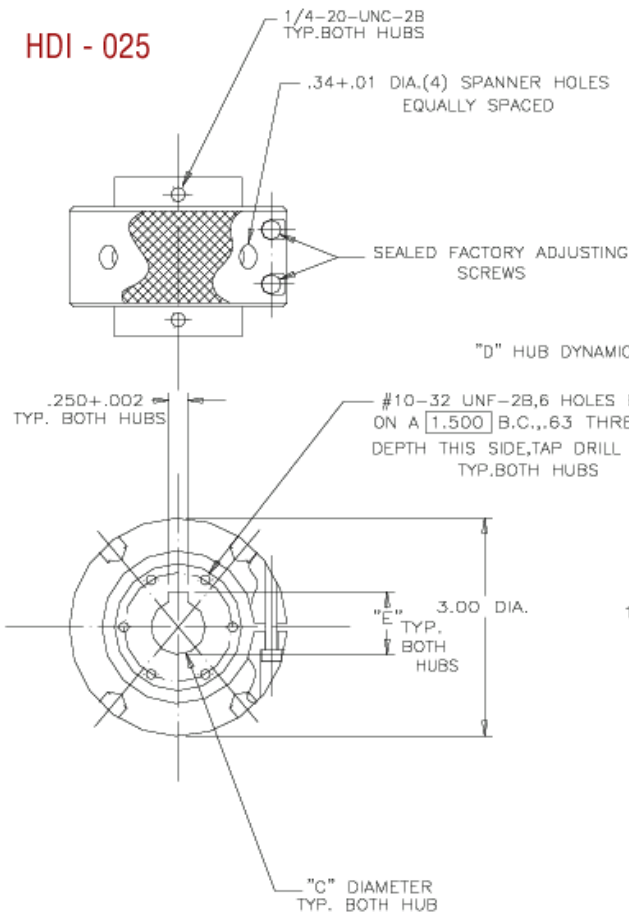

NOTE:
 Maximum Bore Diameter
 not to exceed 1.00 in.

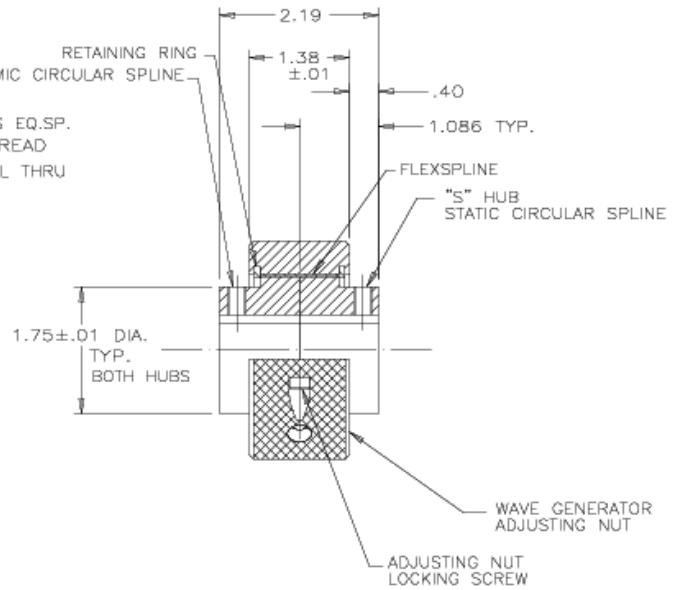

Sold & Serviced By:



Toll Free Phone (877) SERV098
 Toll Free Fax (877) SERV099
 www.electromate.com
 sales@electromate.com

HDI 059

NOTE:
 Maximum Bore Diameter
 not to exceed 1.25 in.

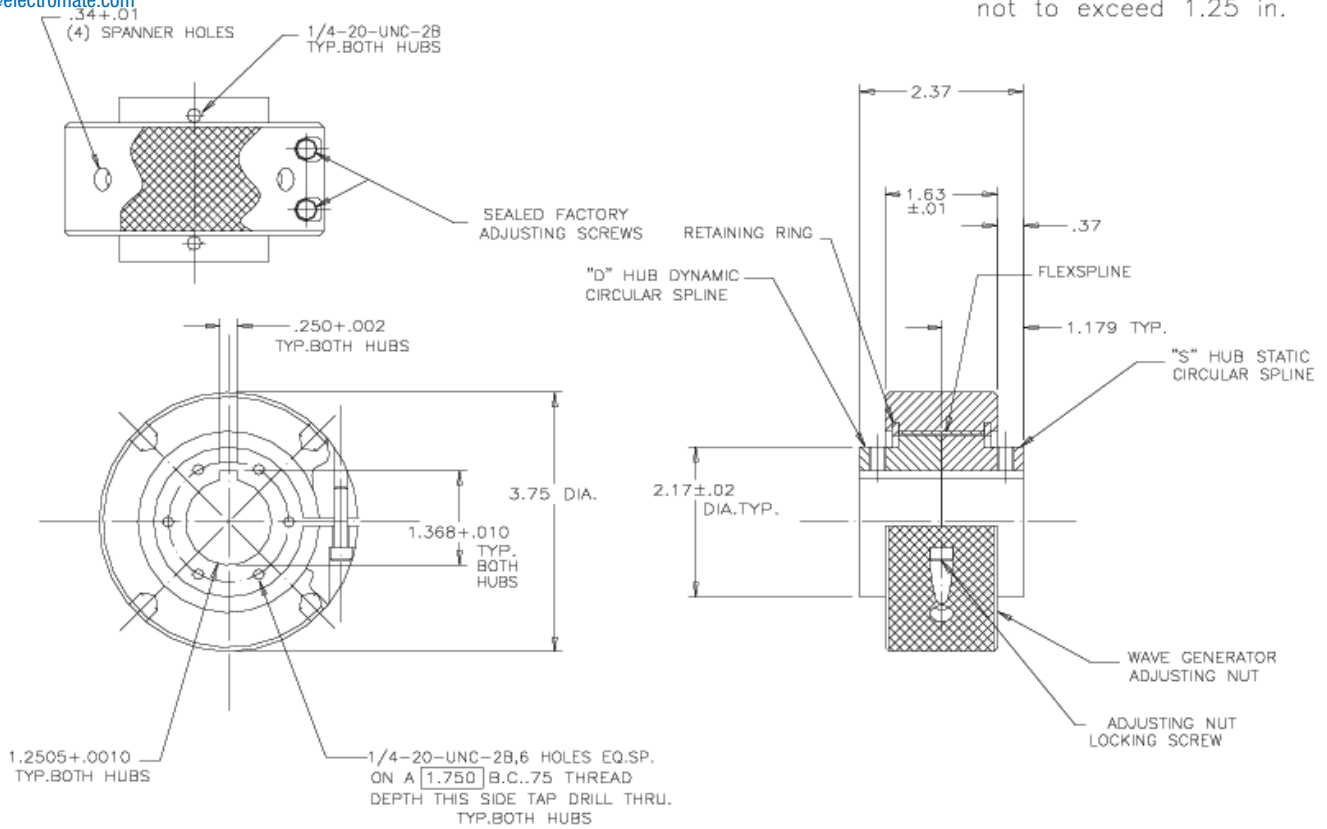

Special Order

HDI phase adjusters are available in 6 sizes. All sizes are furnished complete with hubs to specific order requirements. Several bore sizes are available with keyways and tapped holes on one or both hubs or in minimum plain bore for alteration by the user.

Sold & Serviced By:



Toll Free Phone (877) SERV098

Toll Free Fax (877) SERV099

www.electromate.com
sales@electromate.com

Special Order by Configuration

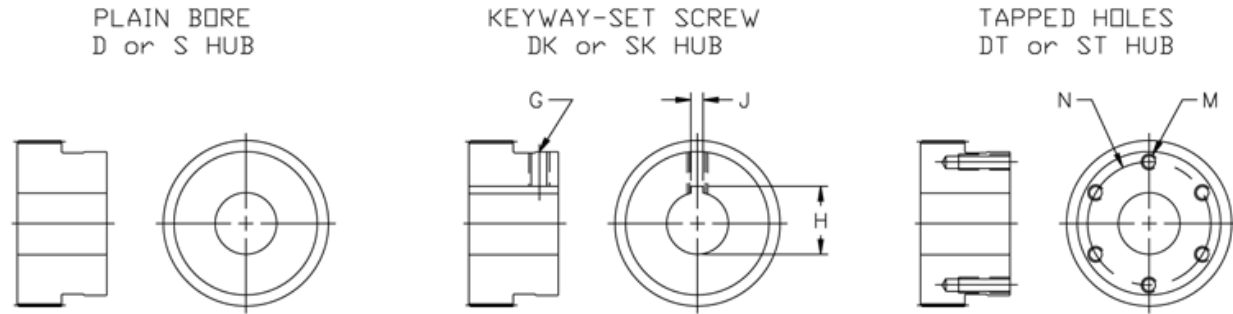

Dimensions are in inches

BASIC HDI SIZE	BORE SIZE	D HUB	S HUB	D HUB	S HUB	G	H	J	D HUB	S HUB	M* UN-2B	N
-05	.250	2D	2S	2DK	2SK	8-32			2DT	2ST	6-32	.750
	.375	3D	3S	3DK	3SK	8-32	.409	.062	3DT	3ST	6-32	.750
	.500	4D	4S	4DK	4SK	8-32	.561	.125	4DT	4ST	6-32	.750
-10	.500	4D	4S	4DK	4SK	1/4-20	.585	.187	4DT	4ST	8-32	1.125
	.625	5D	5S	5DK	5SK	1/4-20	.710	.187	5DT	5ST	8-32	1.125
	.750	6D	6S	6DK	6SK	1/4-20	.837	.187	6DT	6ST	8-32	1.125
-25	.750	6D	6S	6DK	6SK	1/4-20	.863	.250	6DT	6ST	10-32	1.500
	.875	7D	7S	7DK	7SK	1/4-20	.988	.250	7DT	7ST	10-32	1.500
	1.000	8D	8S	8DK	8SK	1/4-20	1.114	.250	8DT	8ST	10-32	1.500
-50	1.000	8D	8S	8DK	8SK	1/4-20	1.114	.250	8DT	8ST	1-4-20	1.750
	1.250	10D	10S	10DK	10SK	1/4-20	1.368	.250	10DT	10ST	1/4-20	1.750
-100	1.250	10D	10S	10DK	10SK	3/8-16	1.418	.75	10DT	10ST	5/16-18	2.500
	1.625	13D	13S	13DK	13SK	3/8-16	1.793	.375	13DT	13ST	5/16-18	2.500
	1.750	14D	14S	14DK	14SK	3/8-16	1.918	.375	14DT	14ST	5/18-18	2.500
-200	1.750	14D	14S	14DK	14SK	1/2-13	2.026	.625	14DT	14ST	3/8-16	3.125
	2.000	16D	16S	16DK	16SK	1/2-13	2.276	.625	16DT	16ST	3/8-16	3.125
	2.500	20D	20S	20DK	20SK	1/2-13	2.778	.625	20DT	20ST	3/8-16	3.125

TO ORDER: Specify the basic HDI size and the desired "D" and "S" hub configuration. Examples: (1) and HDI-10-6D-6SK specifies a basic HDI-10 size unit with one hub .750" plain bore and the other .750" bore with keyway and setscrew. (2) an HDI-25-8DT-8SK specifies a basic HDI-25 size unit with one hub 1.0 bore with tapped holes, the other 1.0 bore with keyway and setscrew.

* Sizes HDI-05 and HDI-10 have three equally spaced UN-2B tapped holes

Sizes HDI-25, HDI-50, HDI-100 and HDI-200 have six equally spaced UN-2B tapped holes. True position of holes .015 diam.

Sold & Serviced By:



Toll Free Phone (877) SERV098

Toll Free Fax (877) SERV099

www.electromate.com

sales@electromate.com

Special Order by Dimension

HDI phase adjusters are available in 6 sizes. All sizes are furnished complete with hubs to specific order requirements. Several bore sizes are available with keyways and tapped holes on one or both hubs or in minimum plain bore for alteration by the user.

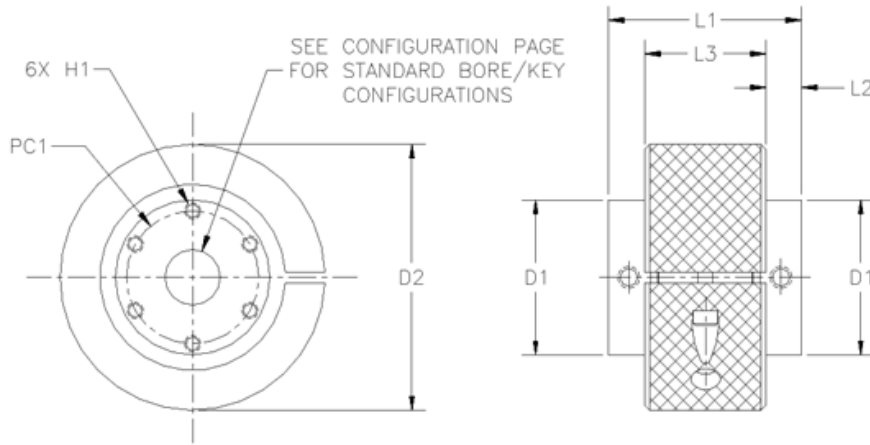

Dimensions are in inches

HDI SIZE						
	5	10	25	50	100	200
D1	1	1.38	1.75	2.17	2.94	3.75
D2	2	2.38	3.00	3.75	4.75	6.5
L1	1.43	1.69	2.19	2.37	3.29	4.05
L2	26	0.31	0.40	0.37	0.62	0.84
L3	0.91	1.06	1.38	1.63	2.06	2.38
H1	#6-32	#8-32	#10-32	1/4-20	5/16-18	3/8-16
PC1	0.75	1.125	1.500	1.750	2.5	3.125
Torque	500	1000	2500	5000	10000	20000
Weight	1.2	1.5	3.00	5.00	11	24

Sold & Serviced By:

ELECTROMATE

Toll Free Phone (877) SERV098

Toll Free Fax (877) SERV099

www.electromate.com

sales@electromate.com

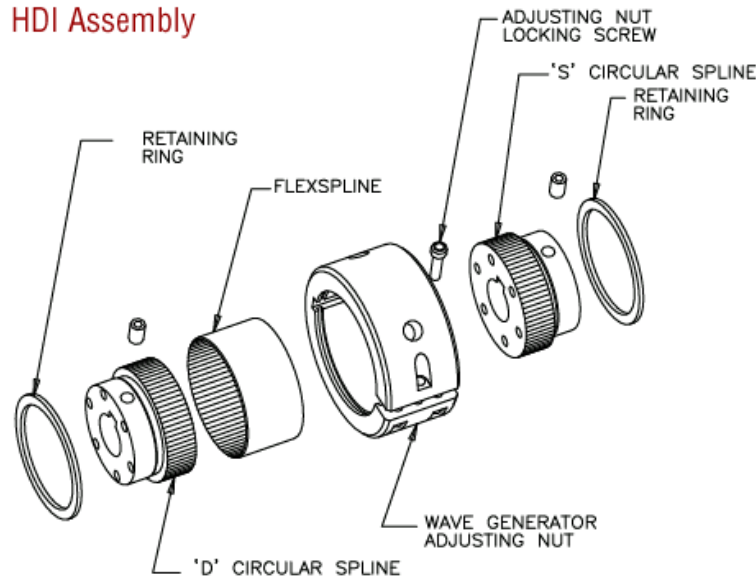
HDI Assembly**Materials:**

Circular splines: low carbon steel/phosphate coated. Adjusting ring: low carbon steel/black oxide coated.

Lubrication:

The unit is factory lubricated and will not require further maintenance under normal conditions. Nevertheless, periodic maintenance should be performed when unit is subject to frequent adjustment, dirty or other abnormal conditions, or when unit-adjusting torque becomes higher than normal.

Disassembly:

Loosen friction adjustment/locking screw (it is not necessary to remove screw from unit) and remove one retaining ring. All parts will then slide out in one direction. (Do not tamper with or remove the two factory alignment screws.)

Clean parts and relubricate with multipurpose EP-2 grease.

Reassembly:

Assemble units with one 'D' and one 'S' hub (each is stamped). Unit will not phase adjust with two 'S' splines or two 'D' splines.

Operation:

Hand rotate the adjusting ring in either direction to produce a 100:1 reduction between the ring and one of the hubs. Adjust the friction adjustment/locking screw to desired resistance. For some applications, one adjustment will be sufficient for both shaft turning and phase adjusting modes. For more sever loading, such as hard stopping or higher torques, the friction adjustment/locking screw may be used to lock the adjusting ring in place to maintain phase.

Sold & Serviced By:



Toll Free Phone (877) SERV098

Toll Free Fax (877) SERV099

www.electromate.com

sales@electromate.com

Installation

The INFINIT-INDEXER is installed in a machine system either as an in-line shaft coupling per Fig. 1 and Fig. 2 or parallel shaft coupling per Fig. 3.

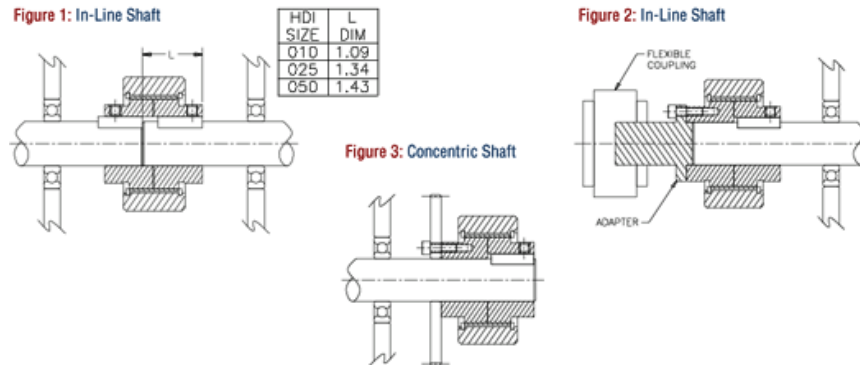

In-Line Shaft

1. The hubs per Fig. 1 are attached to the driving and driven shafts by pin or key/setscrew at the designer's option.
2. In order to properly align shafts concentric to one another, either the driven or driving shaft should pass completely through one hub and engage the other by an amount determined by the "L" dimension. The hubs are symmetrical; therefore, the "L" length applies to a piloting shaft length entering from either hub face.
3. The coupling is designed to transmit pure torque only. Radial reaction loads generated by gears, sprockets, shaft misalignment, etc., must be isolated from the unit by appropriate shaft bearing supports. When it is not possible to maintain good shaft concentricity, it is recommended that the INFINIT-INDEXER be mounted in conjunction with a flexible coupling and adapter as noted in Fig. 2.

Parallel Shaft

1. One hub is connected to the shaft by either pin or key/setscrew at the designer's option per Fig. 3.
2. Connection of a gear, sprocket, etc., is by means of a tapped hole hub.
3. The shaft should pass completely through the attached sprocket, gear, etc., and the INFINIT-INDEXER at a uniform diameter with a tight running fit.

Sold & Serviced By:



Toll Free Phone (877) SERV098

Toll Free Fax (877) SERV099

www.electromate.com

sales@electromate.com

Applications

The Infinitt Indexer provides the designer with a simple component which will solve a variety of design problems that require precise shaft phase adjustments.

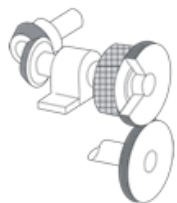

Phasing Gears

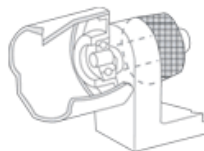

Adjusting an Eccentric



Phasing Cams

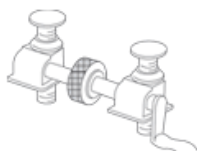

Aligning Level Jacks

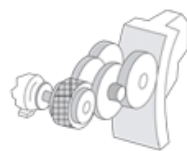
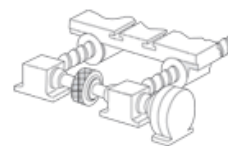
Adjusting Dual Gear Train
Backlash Element

Aligning Part of a Machine Tool

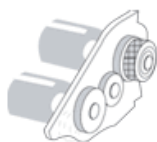

Adjusting Printing Rolls



Adjusting Linkage



Adjusting Backlash on Ball Nuts

Adjustment

One revolution of the knurled outer nut results in 3.6 degrees of shaft phase adjustment. With the "D" hub fixed, rotation of the "S" hub is opposite to the direction of nut rotation. With the "S" hub fixed, rotation at the "D" hub is in the same direction as nut rotation.

The coupling is essentially self-locking, and applications requiring frequent adjustment can be investigated for the possibility of operating without having to seat the locking screw. However, those applications in which the coupling is subjected to typical motor start up accelerations, sudden stops, and/or a vibratory environment will require use of the screw to maintain a phase setting.

The coupling during adjustment is not intended to drive against any significant reaction load that may exist between the connected shafts. However, some adjusting nut torque amplification results to provide a hub drive torque capability within recommended limits noted below.

Dimensions are in inches

Unit Size	Adjustable Nut Input Torque	Hub Output Torque (lb-in)
05	4	20
10	8	40
25	16	80
50	32	160
100	75	380
200	150	750

Spanner wrench holes are provided on the OD of the adjusting nut in sizes 50, 100, and 200.