

# UniOP eTOP513

The UniOP eTOP Series 500 HMI products combine state-of-the-art features and top performance with an outstanding design. They are the ideal choice for all demanding HMI applications including factory and building automation.

The eTOP513 features a bright 13"3 widescreen (16:9) TFT display with a fully dimmable LED backlight.

The JMobile software offers full vector graphic capabilities and plenty of connectivity options.

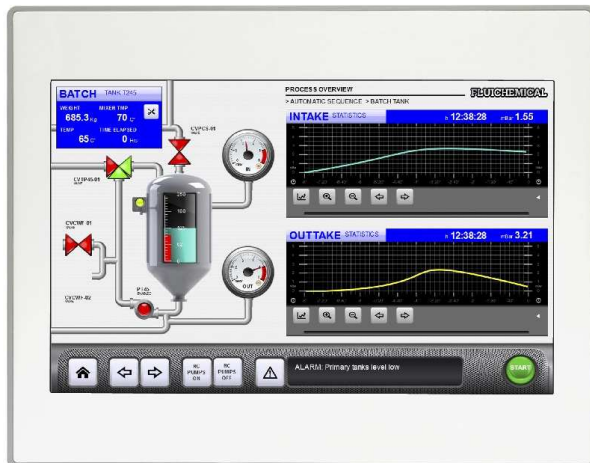

- 13"3 WXGA TFT color display, LED backlight
- 1280x800 pixel resolution, 64K colors
- Resistive touchscreen
- 2 Ethernet ports with switch function
- 2 USB Host ports
- SD Card Slot
- Connection to fieldbus systems and I/O using optional plug-in modules
- Slim design. Mounting depth less than 50mm

## Highlights

The eTOP Series 500 HMI panels have been designed to run the JMobile software.

- JMobile runtime included. Full compatibility with JMobile Studio.
- Full vector graphic support. Native support of SVG graphic objects. Transparency and alpha blending.
- Full object dynamics: control visibility and transparency, move, resize, rotate any object on screen. Change properties of basic and complex objects.
- TrueType fonts
- Multilanguage applications. Easily create and manage your applications in multiple languages to meet global requirements. Far East languages are supported. Tools available in JMobile Studio support easy third-party translations and help reducing development and maintenance costs of the application
- Data display in numerical, text, bargraph, analog gauges and graphic image formats.
- Rich set of state-of-the-art HMI features: data acquisition, alarm handling, scheduler and timed actions (daily and weekly schedulers, exception dates), recipes, users and passwords, e-mail and RSS feeds, rotating menus
- Includes support for a wide range of communication drivers for Factory and Building Automation systems.
- Multiple drivers communication capability.
- Remote monitoring and control. Client-Server functionality. Mobile clients supported.
- Remote maintenance and support with VNC-based functionality.
- Off-line simulation of the HMI application with JMobile Studio.
- Powerful scripting language for automating HMI applications. Script debugging improves efficiency in application development.
- Rich gallery of symbols and objects
- Project templates
- Optional plug-in modules for fieldbus systems, I/O and controllers.
- Display backlight dimmable 0%

## Technical Data

<b>Display</b>		Screen saver	Yes
Type	TFT	Buzzer	Yes, audible feedback for touchscreen
Resolution	1280x800, WXGA		
Active display area	13"3 widescreen diagonal	<b>Ratings</b>	
Colors	64K	Power supply voltage	24 Vdc (10 to 32 Vdc)
Backlight	LED	Current consumption	1.15A at 24Vdc(max.)
Brightness	300 Cd/m <sup>2</sup> typ.	Fuse	Automatic
Dimming	Yes	Weight	Approx 2.8 Kg
		Battery	Rechargeable Lithium battery, not user-replaceable
<b>System Resources</b>		<b>Environmental Conditions</b>	
Operating System	Microsoft Windows CE 6.0	Operating temperature	0 to 50 °C (vertical installation)
User memory	256 MB Flash	Storage temperature	-20 to +70 °C
RAM	256MB DDR	Operating and storage humidity	5 – 85 % relative humidity, non-condensing
		Protection class	IP66 (front) IP20 (rear)
<b>Operator Interface</b>		<b>Dimensions</b>	
Touchscreen	Analog resistive	Faceplate LxH	336x267 mm (13.22x10.51")
LED indicators	1 (dual color)	Cutout AxB	326x256 mm (12.83x10.07")
		Depth D+T	56+4 mm (2.20+0.16")
<b>Interface</b>		<b>Approvals</b>	
Ethernet	2 10/100 Mbit with integrated Switch	CE	Emission EN 61000-6-4 Immunity EN 61000-6-2 for installation in industrial environments
USB	2 Host Interface (1 version 2.0, 1 version 2.0 and 1.1)	DNV	DNV Type Approval Certificate
Serial	RS-232, RS-485, RS-422, software configurable	UL	UL508 Listed Haz. Loc. Class I, Division 2, Groups A,B,C and D.
Expansion Slot	2 Optional plug-in	C-Tick	C-Tick mark
Memory Card	SD Card Slot		
<b>Functionality</b>			
Vector graphics	Yes, includes SVG support		
Object dynamics	Yes. Visibility, opacity, position, size, rotation for most object types.		
TrueType fonts	Yes		
Multiple driver communication	Yes, max 2 drivers		
Data acquisition and trend presentation	Yes. Flash memory storage limited only by available memory		
Multilanguage	Yes, with runtime language switching.		
Recipes	Yes. Flash memory storage limited only by available memory		
Alarms	Yes		
Historical event list	Yes		
Users and passwords	Yes		
Hardware Real Time Clock	Yes, with battery back-up		

**Dimensions**

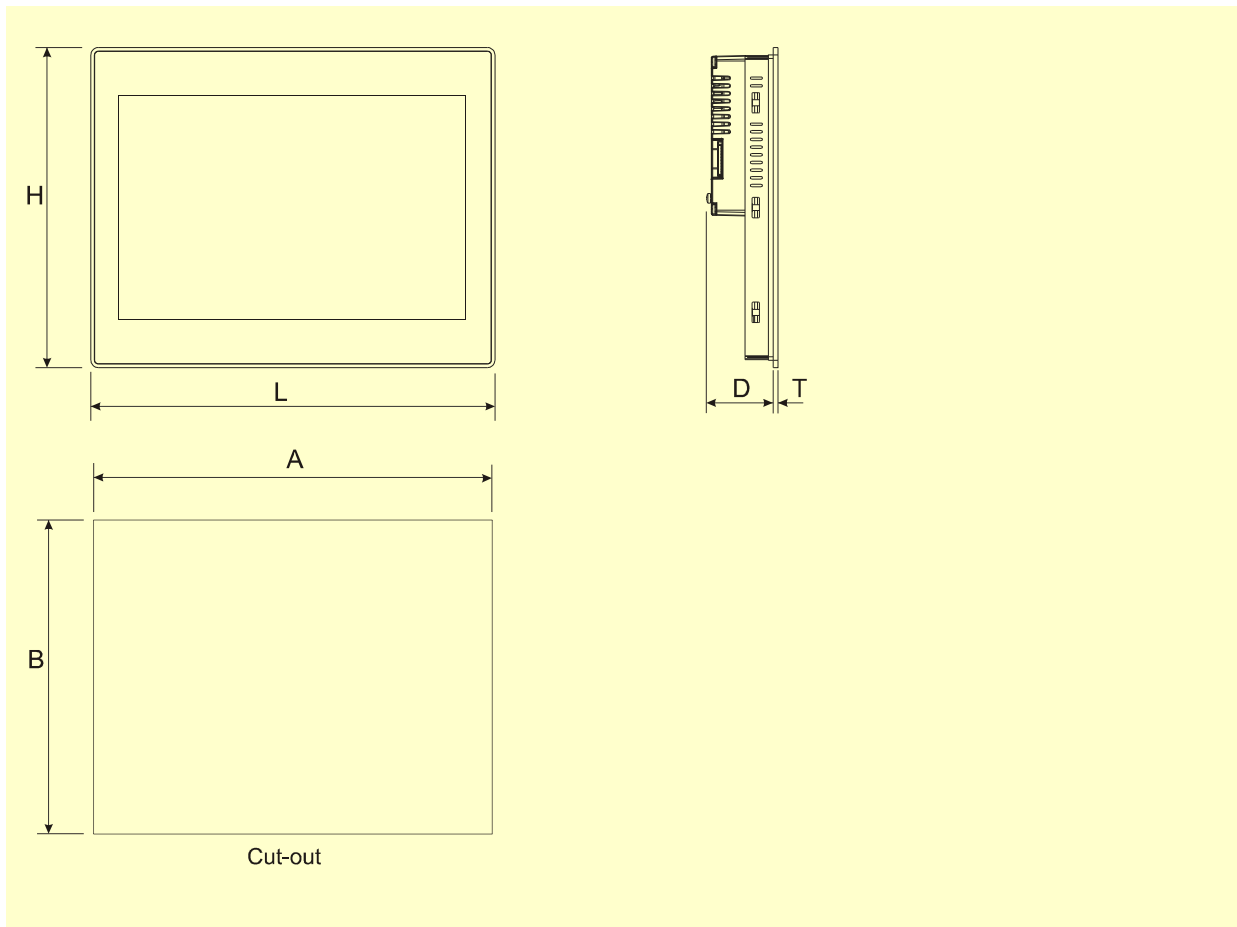

**Connections**

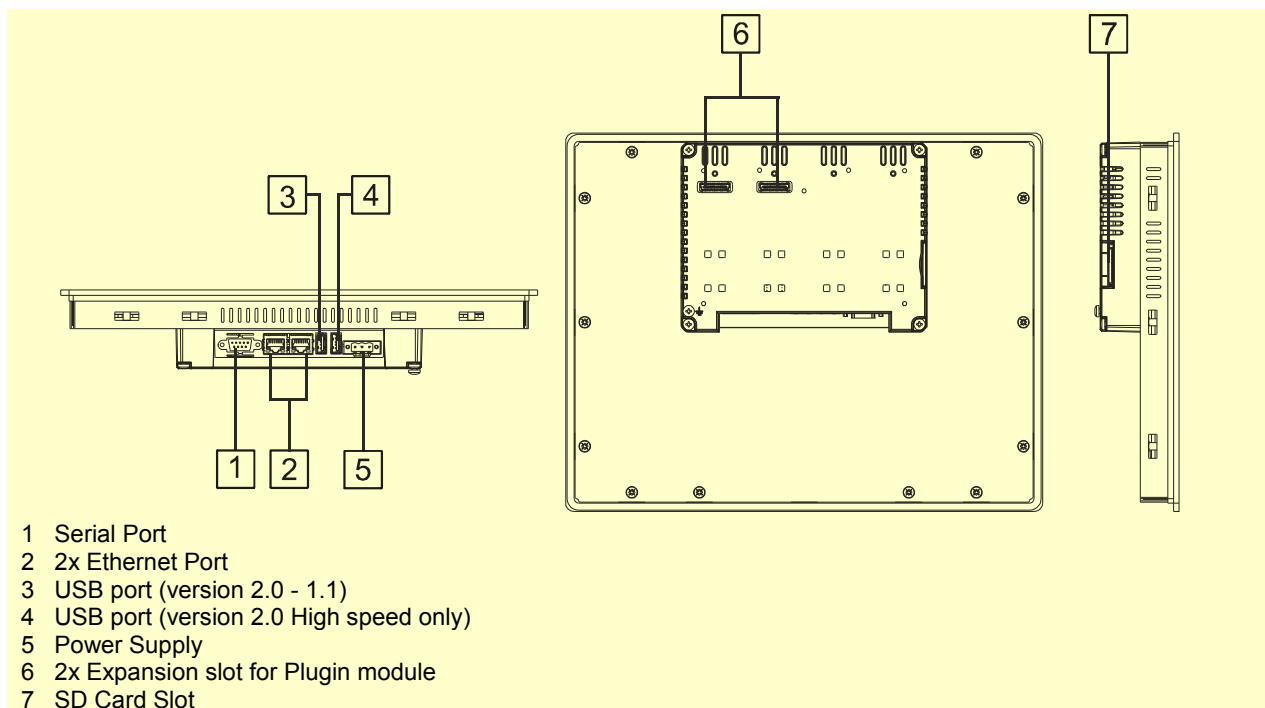

**Ordering Information**

<b>Model</b>	<b>Part Number</b>	<b>Description</b>
eTOP513-White	+ETOP513U1P1	13"3 widescreen TFT color touchscreen with Ethernet and USB interfaces. White front panel. JMobile run-time.
eTOP513-Silver	+ETOP513U2P1	13"3 widescreen TFT color touchscreen with Ethernet and USB interfaces. Silver front panel. JMobile run-time.
eTOP513-Black	+ETOP513U3P1	13"3 widescreen TFT color touchscreen with Ethernet and USB interfaces. Black front panel. JMobile run-time.
PROTFOIL-13-GL	R-PROT15	Disposable protection foil for 13"3 widescreen eTOP touch panels (10 pieces).
PROTFOIL-13-UV	R-PROT21	Disposable protection foil for 13"3 widescreen eTOP touch panels (10 pieces). UV resistant.

---

**ptn0355**

**Ver. 1.6 Copyright © 2011-2014 Exor International S.p.A. – Verona, Italy**

Subject to change without notice

The information contained in this document is provided for informational purposes only. While efforts were made to verify the accuracy of the information contained in this documentation, it is provided "as is" without warranty of any kind.

[www.uniop.com](http://www.uniop.com)