

**EXOR**  
INTERNATIONAL

**EXOR**  
INTERNATIONAL

www.exorint.net

Product Catalogue  
Exor International

45

MKT-BR18-151133



Sold & Serviced By:

 **ELECTROMATE**

Toll Free Phone (877) SERV098

Toll Free Fax (877) SERV099

[www.electromate.com](http://www.electromate.com)

[sales@electromate.com](mailto:sales@electromate.com)



## Exor History

Exor International, an Italian company that for nearly half a century has designed and produced Exor HMI solutions for its partners and thirty distributors who provide and support the products worldwide.

While born into the world of industrial automation and known as the UniOP brand, Exor International has created innovative solutions for the building, industrial automation and marine industries.

The products sold under the UniOP brand are specially designed to respond to the needs of these markets, where flexibility and reliability are a priority.

**EXOR**  
INTERNATIONAL

### Index

- Exor International
- JMobile
- JM4web
- JMobile PC Runtime
- JMcloud – Smart Solution for HMI and PLC Remote Control
- eTOP Series 600 - True Glass HMI
- eTOP Series 500
- eTOP Series 500 Glass for HARSH application - No Limits HMI
- HMI + PLC
- eTOP507MFB - Designed for Food and Beverage industry
- eTOP Series 500W - Open Platform
- eBIS Series 500 - DomiOP
- eSMART Series– Designed for budget critical applications
- ON3 Handheld - Mobile HMI Solutions
- eTOP Series 300
- Key Operated Panels and Legacy Products - UniOP
- iPC - Products for PC-based automation

Sold & Serviced By:

 **ELECTROMATE**

Toll Free Phone (877) SERV098

Toll Free Fax (877) SERV099

[www.electromate.com](http://www.electromate.com)

[sales@electromate.com](mailto:sales@electromate.com)

## A New Software Generation!

JMobile is a modern and innovative software platform for the design of HMI applications in a simple and intuitive way. A powerful and versatile tool set allowing for the rapid design of tailored applications crafted for a better, more modern user experience. Designed for simplicity, flexibility and efficiency, JMobile includes an advanced graphics engine based on SVG technology with full object-oriented design properties. A gallery of modern and flexible widgets allow for tailoring a truly better, more intuitive "User Experience", better "Usability" for operators with modern widgets and navigation, better "Visibility" for management with remote tools and reporting, and better "Serviceability" both locally and from afar.

JMobile client-server architecture is based on current HTML5 web technologies providing users with advanced control and remote supervision from any browser, any device (smartphone, tablet, or computer). In addition, the ability to capture, store and share data in higher-level structures make it an effective tool for integration across the entire enterprise. A rich set of symbols, widgets and advanced functions (e-mail, RSS, PDF Reporting, Scheduler, HTML5 Browser) allows JMobile deployment in a wide variety of applications and industries, from industrial to building and marine automation.

## The Programming Environment

- Simple and intuitive interface
- Project tree organized design resources
- Toolbars for quick access
- Property Tree for advanced widget programming
- Gallery of widgets
- Gallery for user defined widgets
- Powerful JavaScript engine with debugger for HMI & Tag functions
- Large "ready to use" macro library
- Advanced User & Password management
- Audit Trail traceability
- Multilanguage with import and export texts
- Scheduler and event planning
- Recipes
- Alarms with import and export
- Datalogging Realtime & Historical trending
- Tag cross Reference viewer
- Indexed Tag addressing
- On-line and off-line simulation
- Optional IEC 61131-3 integrated PLC (CODESYS V2 or V3)
- eMail with SSL authentication support
- Remote monitor & control features

JMobile®

## Advanced Vector Graphic

- SVG vector graphics
- Animation
- Dynamic widget properties connected to Tags
- Dynamic interaction between properties of different widgets
- Widget properties accessible via Javascript
- TrueType fonts
- Rich gallery of symbols and widgets
- Page Templates
- Video player

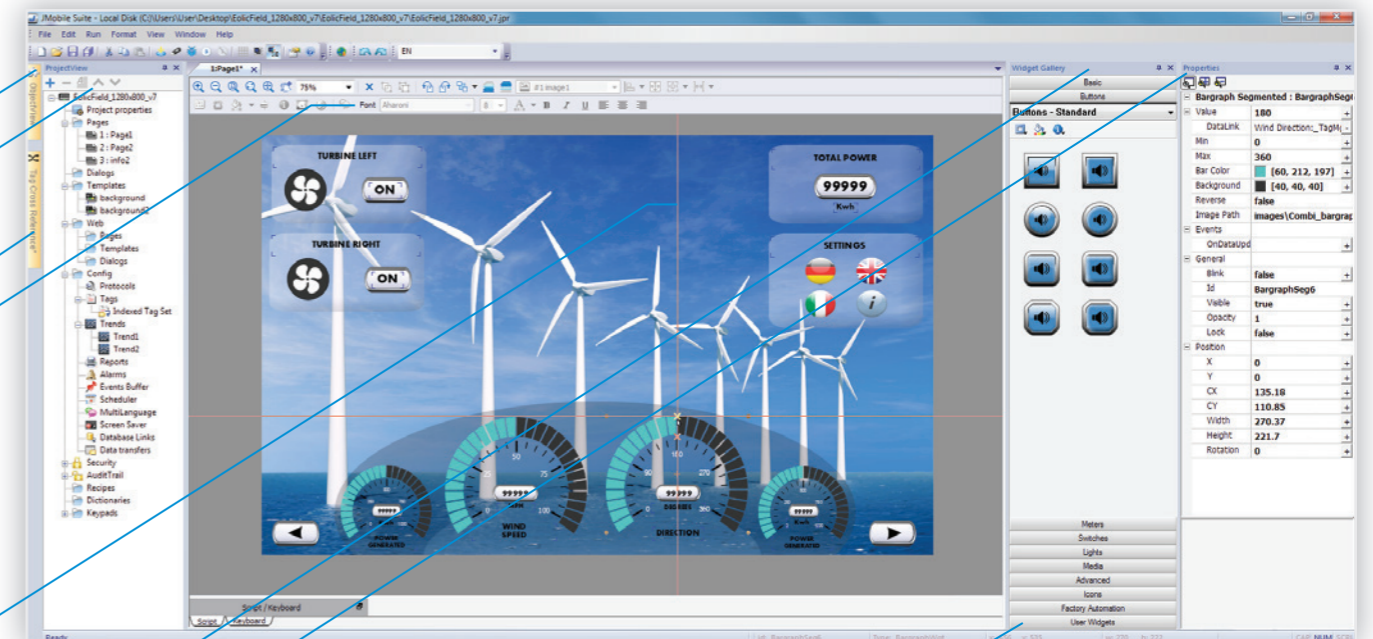

Object View

Project Tree

Tag Cross Reference Tool

Quick Access Toolbar

Snap to Grid Alignment tool

Widget Gallery

Property Editor

User Widget Gallery

## Communication and Gateway

- Support for all industrial communication protocols
- Supports up to 4 simultaneous protocols
- Gateway function between different protocols
- Support for internal variables (optionally retentive)
- Integrated Web Server
- Integrated Web Browser
- E-Mail Alerts with live data and attachments
- Supports VNC technology for remote desktop



Sold & Serviced By:

**ELECTROMATE**

Toll Free Phone (877) SERV098

Toll Free Fax (877) SERV099

www.electromate.com

sales@electromate.com

## Your HMI Everywhere!

JM4web is the seamless connection between your HMI application and your ubiquitous mobile devices such as smart phones and tablets. Thanks to the HTML5 and Javascript technology embedded in JMobile, all that is needed to remotely monitor & control your Exor HMI is a web browser with HTML5 support. Firefox, Chrome, Safari and Internet Explorer will do the job. No "apps" needed when operating from mobile devices!

With JM4web you can have instant Web access to JMobile applications via the integrated Web server included in all JMobile runtime systems. JM4web allows for creating the exact user experience for the target mobile device.

Simply exporting pages from a 10", 12", or 15" HMI leads to a difficulty viewing & operating on a small mobile device such as a smartphone. JMobile Studio allows you to quickly and easily create the desired widget size and layout to maximize the user experience.

You can create JM4web pages optimized for viewing on smart phones, tablets or computers. The Web server will detect the resolution of the connected client device and serve the appropriate pages.

JM4web is the ideal complement to the powerful remote connectivity and visualization tools already available in JMobile, including the native Win32 Client and the VNC client/server access.



JM4web   

Sold & Serviced By:

 **ELECTROMATE**

Toll Free Phone (877) SERV098

Toll Free Fax (877) SERV099

[www.electromate.com](http://www.electromate.com)

[sales@electromate.com](mailto:sales@electromate.com)

**EXOR**  
INTERNATIONAL

## JMobile PC Runtime Main Features

JMobile PC Runtime is the Windows version of our powerful programming software for graphic user interfaces. The developer can program within a single development environment (JMobile Studio) and choose to download to Exor HMIs or industrial PCs.

The feature set of JMobile PC Runtime is identical to those offered for Exor HMIs with the ability to utilize the computing power, flexibility, and expandability of a PC. Many serial and Ethernet communication protocols are available.

Value, functionality, and price make JMobile PC Runtime ideal for replacing generic SCADA with a cost effective solution.

JMobile Runtime is offered in a single version with 4000 tags for a single price, simplifying the costing decision.

## System Requirements

Windows XP, Windows Vista, Windows 7, Windows 8  
Windows XP Embedded, Windows Embedded Standard 2009,  
Windows Embedded Standard 7, Windows 2003 Server  
Minimum of 256 MB of disk space  
Minimum of 512 MB of RAM



**JMobile® Studio**  
the human machine interface



Sold & Serviced By:

 **ELECTROMATE**

Toll Free Phone (877) SERV098

Toll Free Fax (877) SERV099

[www.electromate.com](http://www.electromate.com)

[sales@electromate.com](mailto:sales@electromate.com)

## JMcloud – Smart Solution for HMI and PLC Remote Control

JMcloud is a secure Open VPN and SSL based solution that allows to remotely manage industrial installation connected to a centralized server through gateways.

### JMcloud components:

**JMcloud server** is the heart of the whole infrastructure. It stores all the configuration data, the log files, the access policies, and keeps track of the connections to the endpoints.

**JMcloud Connect** is a Windows application used to connect to the JMcloud server and view and connect to all devices enabled and belonging to that domain.

**HMI Cloud Enabler** is software solution for Series 500/600 HMI. It uses only one Ethernet port for PLC and for Cloud connection.

**PLCM07 Secure Cloud Connector** is a hardware solution for series 500/600 HMI. It uses two separate Ethernet ports, LAN for HMI/PLC and WAN for Cloud connection.

JMcloud reduces cost and time for installation and maintenance. You can work on HMI and PLC installed on site from your office using an all-in-one solution.

For further information:  
<http://jmcloud.exorint.net/>

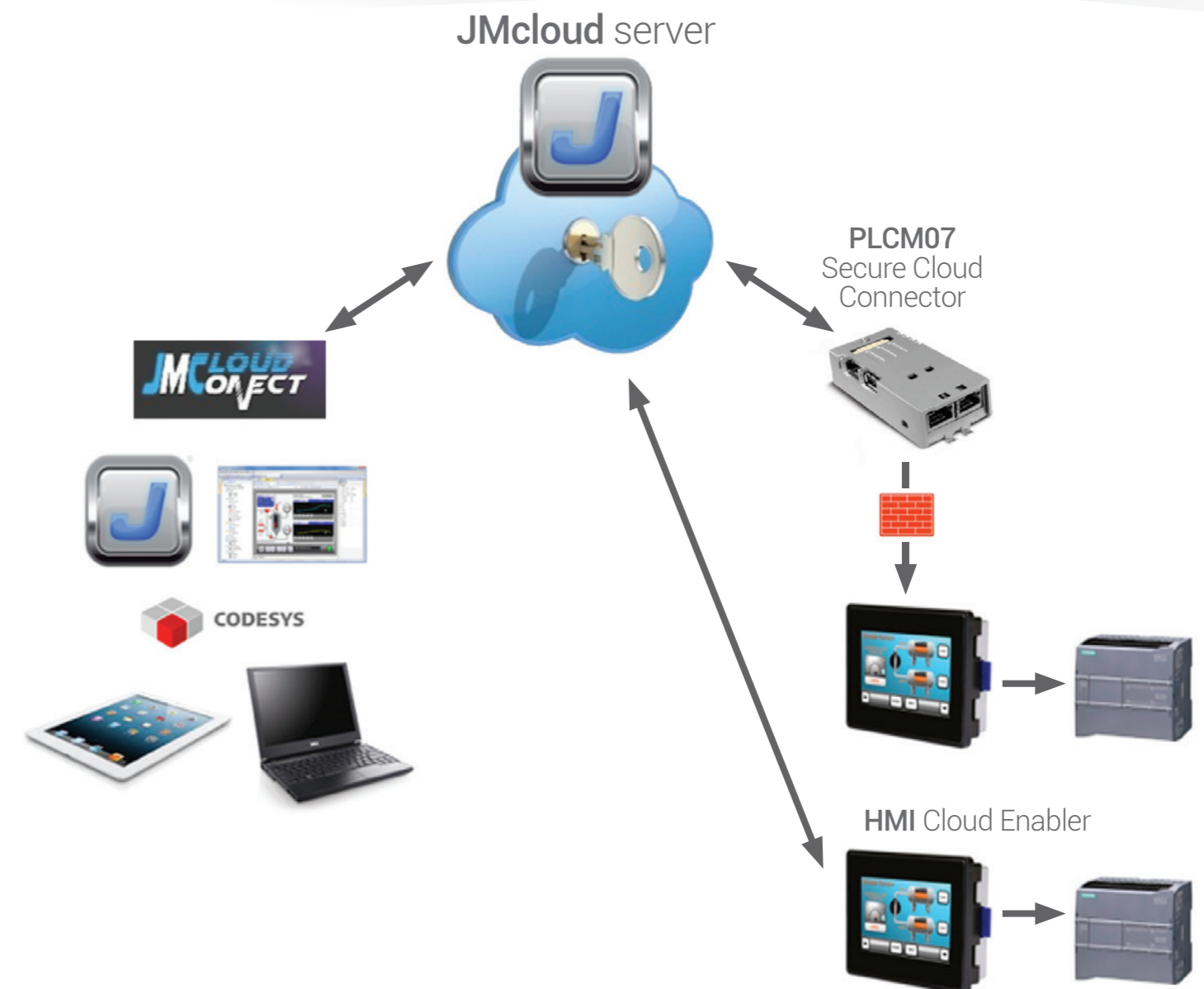

# JMcloud

JMcloud Smart Solution for HMI and PLC Remote Control

Sold & Serviced By:

 **ELECTROMATE**

Toll Free Phone (877) SERV098

Toll Free Fax (877) SERV099

[www.electromate.com](http://www.electromate.com)

[sales@electromate.com](mailto:sales@electromate.com)

## eTOP Series 600 - True Glass HMI Main Features

- Projected **Capacitive True Glass** Touchscreen
- Display Size Range from 5" to 21.5"
- **Widescreen** Display - All Models
- **5 Year Warranty**
- High Resolution & **Optical Performance**
- Data Bridge - Gateway Functionality
- Remote Monitor, Control and Maintenance Functionality
- **Brilliant Display** with LED Backlight Technology
- Ethernet, USB and Serial Ports; Integrated Siemens MPI support
- Fieldbus and Network Support
- SD Card for Extended Data Storage
- **Scratch & Harsh Chemical Resistant** Surface
- Coating on all Electronic Boards
- Scalable Performance
- **UV Resistant**
- Highly Reliable, Industrial Grade Components
- Modular System Design
- DNV \*
- UL Class I, Div. 2 Haz. Loc. \*
- Extended Temperature Range (-20 °C +60 °C)
- Low Power Consumption
- **Wide Range Power** Supply (10 to 32 Vdc)



SERIES  
**600**  
TRUE GLASS HMI

Sold & Serviced By:

 **ELECTROMATE**

Toll Free Phone (877) SERV098

Toll Free Fax (877) SERV099

[www.electromate.com](http://www.electromate.com)

[sales@electromate.com](mailto:sales@electromate.com)



	eTOP605	eTOP607M	eTOP610
Display - Colors	5" TFT 16:9 LED - 64K	7" TFT 16:9 LED - 64K	10.1" TFT 16:9 LED - 64K
Resolution	800x480, WVGA	800x480, WVGA	1280x800, WXGA
Brightness	200 Cd/m <sup>2</sup> typ.	300 Cd/m <sup>2</sup> typ.	300 Cd/m <sup>2</sup> typ.
Dimming	Yes	Yes	Yes
Touchscreen	True Glass Projected Capacitive	True Glass Projected Capacitive	True Glass Projected Capacitive
Portrait Mode	Yes	Yes	Yes
CPU	ARM Cortex-A8 - 600 MHz	ARM Cortex-A8 - 1 GHz	ARM Cortex-A8 - 1 GHz
User Memory	128 MB Flash	256 MB Flash	256 MB Flash
Serial	RS-232, RS-485, RS-422, MPI software configurable	RS-232, RS-485, RS-422, MPI software configurable	RS-232, RS-485, RS-422, MPI software configurable
Ethernet	2 10/100 Mbit with integrated Switch	2 10/100 Mbit with integrated Switch	2 10/100 Mbit with integrated Switch
USB	1 Host interface (version 2.0 and 1.1)	2 Host interfaces (1 version 2.0, 1 version 2.0 and 1.1)	2 Host interfaces (1 version 2.0, 1 version 2.0 and 1.1)
Vector Graphics	Yes, includes SVG support	Yes, includes SVG support	Yes, includes SVG support
Object dynamics	Yes	Yes	Yes
TrueType fonts	Yes	Yes	Yes
Alarms with historical list	Yes	Yes	Yes
Recipes and Password	Yes	Yes	Yes
Trends	Yes	Yes	Yes
Multilanguage	Yes	Yes	Yes
Reports	PDF / USB Printer	PDF / USB Printer	PDF / USB Printer
PDF Reader	Optional	Yes	Yes
Video Player	No	Yes	Yes
IP Camera	Frame / Streaming MJPEG	Frame / Streaming MJPEG	Frame / Streaming MJPEG
Communication / Gateway	4 protocols	4 protocols	4 protocols
Real Time Clock	Yes, with battery	Yes, with battery	Yes, with battery
Battery	Rechargeable Lithium Battery	Rechargeable Lithium Battery	Rechargeable Lithium Battery
Expansion Slot	1 Optional Plugin	2 Optional Plugin	2 Optional Plugin
Memory card	SD Card Slot	SD Card Slot	SD Card Slot
Power Supply	24 Vdc (10 to 32 Vdc)	24 Vdc (10 to 32 Vdc)	24 Vdc (10 to 32 Vdc)
Current Consumption	0.6A at 24Vdc (max.)	0.6A at 24Vdc (max.)	1.0A at 24Vdc (max.)
Operating Temperature	-20 to +60 °C	-20 to +60 °C	-20 to +60 °C
Storage Temperature	-20 to +70 °C	-20 to +70 °C	-20 to +70 °C
Operating and storage humidity	5 - 85%, RH non-condensing	5 - 85%, RH non-condensing	5 - 85%, RH non-condensing
Weight	Approx. 1.0 Kg	Approx. 1.3 Kg	Approx. 1.7 Kg
Faceplate (LxH)	147x107 mm	187x147 mm	282x197 mm
Cut-out (AxB)	136x96 mm	176x136 mm	271x186 mm
Depth (D+T)	56 + 8 mm	47 + 8 mm	56 + 8 mm
Protection Class front / rear	IP66 / IP20	IP66 / IP20	IP66 / IP20
Approvals	CE, DNV *, ATEX * / cULus Class I, Div. 2 *	CE, DNV *, ATEX * / cULus Class I, Div. 2 *	CE, DNV *, ATEX * / cULus Class I, Div. 2 *

PLCM01 PLCM01-CDS PLCM05 PLCM05-CDS	Plug-in module CAN Plug-in module CAN + CODESYS V2 Plug-in extender for use with PLIO03 (only for eTOP605) Plug-in module CODESYS V2
PLCM02 PLCM02-CDS	Plug-in module for KNX/EIB (TP interface) Plug-in module for KNX/EIB (TP interface) + CODESYS V2
PLIO03	I/O module with 20 DI 24VDC, 12 DO 24VDC 0,5 A, 8 Programmable AI, 4 Programmable AO, 1 PT100
PLIO04	I/O Module with 10 DI 24VDC, 10 DO SSR 1.4 A, 4 Programmable AI voltage/PT100/TC, 4 AI voltage, 1 PT100
PLIO06	Compact I/O module. 8 DI, 6 DO, 1 Relay Output
PLIO07	Compact I/O module. 2 Relay Outputs
PLCM03 PLCM04	Plug-in module RS-232 Plug-in module RS-422/485 with optical insulation
PLCM06	Plug-in module Profibus DP slave 12 Mb
PLCM07	Secure Cloud Connector



Sold & Serviced By:

**ELECTROMATE**  
Toll Free Phone (877) SERV098  
Toll Free Fax (877) SERV099  
www.electromate.com  
sales@electromate.com

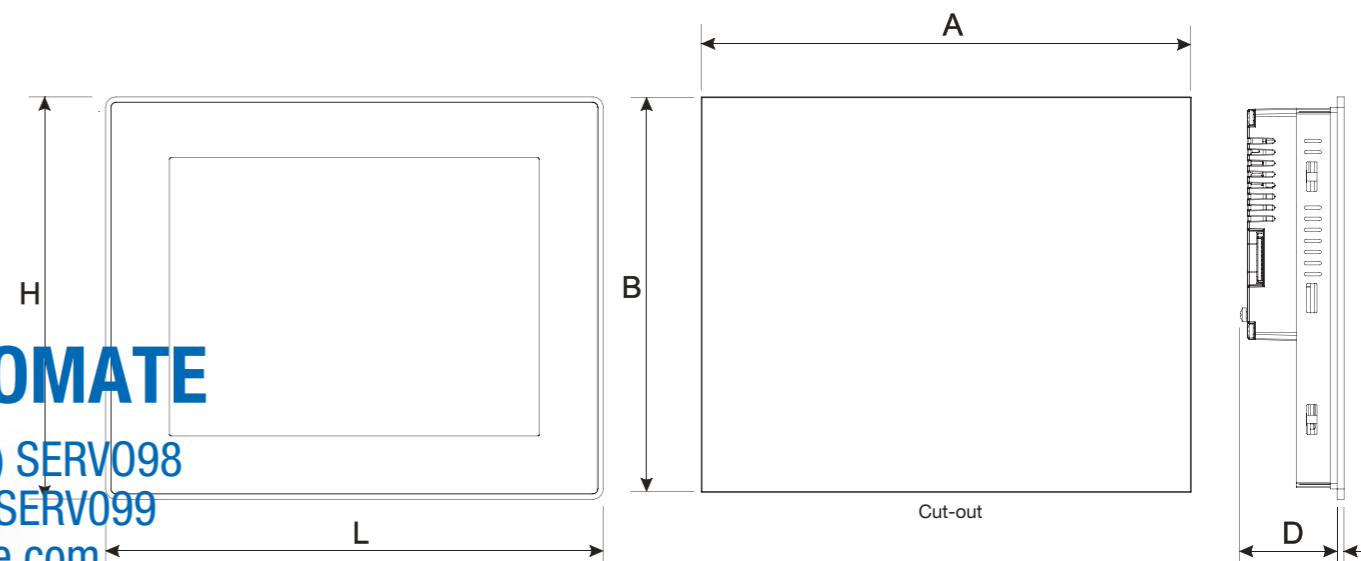



## eTOP Series 500 - Solid as a Rock Main Features

- 5 Year Warranty
- Innovative mechanical design and all-metal enclosure
- Available in different sizes from 4.3" to 15"
- High-performance touchscreen HMI's
- Brilliant displays with LED technology all in full color
- Gateway function, remote installation of application and remote assistance
- Ethernet, USB, serial ports and MPI integrated
- Optional plug-in modules for fieldbus systems and networks
- Support SD Card
- Coating on all Electronic Boards
- Optional IEC 61131-3 integrated PLC (CODESYS V2 or V3)
- Front available in three colors (White/Black/Silver)
- Special versions for special applications

## HMI Products designed as the ideal platform for JMobile applications

- Powerful and intuitive programming with JMobile Studio
- Support of a wide range of communication drivers
- Data display as numerical, text, bargraph, analog gauges and graphic image formats
- Data acquisition and trend presentation
- Recipe data handling
- Full support of multilanguage applications
- Powerful script language
- Alarm handling
- User and group access control
- Monitoring and remote control
- Report printing to USB printer
- Optional IEC 61131-3 integrated PLC (CODESYS V2 or V3)
- Rich set of HMI features: dynamic objects, data acquisition, alarm handling, Multilanguage applications, recipes, tag editor and tag database, user and password, scripting...
- Rich symbol library and project templates
- On-line and off-line simulation for applications
- Advanced HMI objects: e-mail, RSS feeds, Scheduler, Rotating menu, IP Video input



SERIES  
**500**  
SOLID AS A ROCK

Sold & Serviced By:



Toll Free Phone (877) SERV098

Toll Free Fax (877) SERV099

[www.electromate.com](http://www.electromate.com)

[sales@electromate.com](mailto:sales@electromate.com)



	eTOP504	eTOP506	eTOP507	eTOP507M	eTOP510	eTOP512	eTOP513	eTOP515
Display - Colors	4.3" TFT 16:9 LED - 64K	5.7" TFT LED - 64K	7" TFT 16:9 LED - 64K	7" TFT 16:9 LED - 64K	10"4 TFT LED - 64K	12"1 TFT LED - 64K	13"3 TFT 16:9 LED - 64K	15" TFT LED - 64K
Resolution	480x272, WQVGA	320x240, QVGA	800x480, WVGA	800x480, WVGA	800x600, SVGA	800x600, SVGA	1280x800, WXGA	1024x768, XGA
Brightness	150 Cd/m <sup>2</sup> typ.	200 Cd/m <sup>2</sup> typ.	300 Cd/m <sup>2</sup> typ.	300 Cd/m <sup>2</sup> typ.	300 Cd/m <sup>2</sup> typ.	300 Cd/m <sup>2</sup> typ.	300 Cd/m <sup>2</sup> typ.	300 Cd/m <sup>2</sup> typ.
Dimming	Yes	Yes	Yes	Yes	Yes	Yes	Yes	Yes
Touchscreen	Resistive	Resistive	Resistive	Resistive	Resistive	Resistive	Resistive	Resistive
Portrait Mode	Yes	Yes	Yes	Yes	Yes	Yes	Yes	Yes
CPU	ARM Cortex-A8 - 600 MHz	ARM Cortex-A8 - 600 MHz	ARM Cortex-A8 - 600 MHz	ARM Cortex-A8 - 1 GHz	ARM Cortex-A8 - 1 GHz	ARM Cortex-A8 - 1 GHz	ARM Cortex-A8 - 1 GHz	ARM Cortex-A8 - 1 GHz
User Memory	128 MB Flash	128 MB Flash	128 MB Flash	256 MB Flash	256 MB Flash	256 MB Flash	256 MB Flash	256 MB Flash
Serial	RS-232, RS-485, RS-422, MPI software configurable	RS-232, RS-485, RS-422, MPI software configurable	RS-232, RS-485, RS-422, MPI software configurable	RS-232, RS-485, RS-422, MPI software configurable	RS-232, RS-485, RS-422, MPI software configurable	RS-232, RS-485, RS-422, MPI software configurable	RS-232, RS-485, RS-422, MPI software configurable	RS-232, RS-485, RS-422, MPI software configurable
Ethernet	2 10/100 Mbit with integrated Switch	2 10/100 Mbit with integrated Switch	2 10/100 Mbit with integrated Switch	2 10/100 Mbit with integrated Switch	2 10/100 Mbit with integrated Switch	2 10/100 Mbit with integrated Switch	2 10/100 Mbit with integrated Switch	2 10/100 Mbit with integrated Switch
USB	1 Host interface v.2.0	2 Host interfaces (1 version 2.0, 1 version 2.0 and 1.1)	2 Host interfaces (1 version 2.0, 1 version 2.0 and 1.1)	2 Host interfaces (1 version 2.0, 1 version 2.0 and 1.1)	2 Host interfaces (1 version 2.0, 1 version 2.0 and 1.1)	2 Host interfaces (1 version 2.0, 1 version 2.0 and 1.1)	2 Host interfaces (1 version 2.0, 1 version 2.0 and 1.1)	2 Host interfaces (1 version 2.0, 1 version 2.0 and 1.1)
Vector Graphics	Yes, includes SVG support	Yes, includes SVG support	Yes, includes SVG support	Yes, includes SVG support	Yes, includes SVG support	Yes, includes SVG support	Yes, includes SVG support	Yes, includes SVG support
Object dynamics	Yes	Yes	Yes	Yes	Yes	Yes	Yes	Yes
TrueType fonts	Yes	Yes	Yes	Yes	Yes	Yes	Yes	Yes
Alarms with historical list	Yes	Yes	Yes	Yes	Yes	Yes	Yes	Yes
Recipes and Password	Yes	Yes	Yes	Yes	Yes	Yes	Yes	Yes
Trends	Yes	Yes	Yes	Yes	Yes	Yes	Yes	Yes
Multilanguage	Yes	Yes	Yes	Yes	Yes	Yes	Yes	Yes
Reports	PDF / USB Printer	PDF / USB Printer	PDF / USB Printer	PDF / USB Printer	PDF / USB Printer	PDF / USB Printer	PDF / USB Printer	PDF / USB Printer
PDF Reader	Optional	Optional	Optional	Yes	Yes	Yes	Yes	Yes
Video Player	No	No	No	Yes	Yes	Yes	Yes	Yes
IP Camera	Frame / Streaming MJPEG	Frame / Streaming MJPEG	Frame / Streaming MJPEG	Frame / Streaming MJPEG	Frame / Streaming MJPEG	Frame / Streaming MJPEG	Frame / Streaming MJPEG	Frame / Streaming MJPEG
Communication / Gateway	4 protocols	4 protocols	4 protocols	4 protocols	4 protocols	4 protocols	4 protocols	4 protocols
Real Time Clock	Yes, with battery	Yes, with battery	Yes, with battery	Yes, with battery	Yes, with battery	Yes, with battery	Yes, with battery	Yes, with battery
Battery	Rechargeable Lithium Battery	Rechargeable Lithium Battery	Rechargeable Lithium Battery	Rechargeable Lithium Battery	Rechargeable Lithium Battery	Rechargeable Lithium Battery	Rechargeable Lithium Battery	Rechargeable Lithium Battery
Expansion Slot	1 Optional Plug-in	2 Optional Plug-in	2 Optional Plug-in	2 Optional Plug-in	2 Optional Plug-in	2 Optional Plug-in	2 Optional Plug-in	2 Optional Plug-in
Memory card	SD Card Slot	SD Card Slot	SD Card Slot	SD Card Slot	SD Card Slot	SD Card Slot	SD Card Slot	SD Card Slot
Power Supply	24 Vdc (10 to 32 Vdc)	24 Vdc (10 to 32 Vdc)	24 Vdc (10 to 32 Vdc)	24 Vdc (10 to 32 Vdc)	24 Vdc (10 to 32 Vdc)	24 Vdc (10 to 32 Vdc)	24 Vdc (10 to 32 Vdc)	24 Vdc (10 to 32 Vdc)
Current Consumption	0.55A at 24Vdc (max.)	0.65A at 24Vdc (max.)	0.7A at 24Vdc (max.)	0.7A at 24Vdc (max.)	1A at 24Vdc (max.)	1.0A at 24Vdc (max.)	1.2A at 24Vdc (max.)	1.2A at 24Vdc (max.)
Operating Temperature	0 to 50 °C	0 to 50 °C	0 to 50 °C	0 to 50 °C	0 to 50 °C	0 to 50 °C	0 to 50 °C	0 to 50 °C
Storage Temperature	-20 to +70 °C	-20 to +70 °C	-20 to +70 °C	-20 to +70 °C	-20 to +70 °C	-20 to +70 °C	-20 to +70 °C	-20 to +70 °C
Operating and storage humidity	5 - 85%, RH non-condensing	5 - 85%, RH non-condensing	5 - 85%, RH non-condensing	5 - 85%, RH non-condensing	5 - 85%, RH non-condensing	5 - 85%, RH non-condensing	5 - 85%, RH non-condensing	5 - 85%, RH non-condensing
Weight	Approx. 1.0 Kg	Approx. 1.0 Kg	Approx. 1.0 Kg	Approx. 1.0 Kg	Approx. 2.1 Kg	Approx. 2.8 Kg	Approx. 2.8 Kg	Approx. 3.5 Kg
Faceplate (LxH)	147x107 mm	187x147 mm	187x147 mm	187x147 mm	287x232 mm	336x267 mm	336x267 mm	392x307 mm
Cut-out (AxH)	136x96 mm	176x136 mm	176x136 mm	176x136 mm	276x221 mm	326x256 mm	326x256 mm	381x296 mm
Depth (D+T)	56 + 4 mm	47 + 4 mm	47 + 4 mm	47 + 4 mm	56 + 4 mm	56 + 4 mm	56 + 4 mm	60 + 4 mm
Protection Class front / rear	IP66 / IP20	IP66 / IP20	IP66 / IP20	IP66 / IP20	IP66 / IP20	IP66 / IP20	IP66 / IP20	IP66 / IP20
Approvals	CE, DNV / cULus Class I, Div. 2	CE, DNV / cULus Class I, Div. 2	CE, DNV / cULus Class I, Div. 2	CE, DNV* / cULus Class I, Div. 2*	CE, DNV / cULus Class I, Div. 2	CE, DNV / cULus Class I, Div. 2	CE, DNV / cULus Class I, Div. 2	CE, DNV / cULus Class I, Div. 2

PLCM01 PLCM01-CDS PLCM05 PLCM05-CDS	Plug-in module CAN Plug-in module CAN + CODESYS V2 Plug-in extender for use with PLIO03 (only for eTOP504) Plug-in module CODESYS V2
PLCM02 PLCM02-CDS	Plug-in module for KNX/EIB (TP interface) Plug-in module for KNX/EIB (TP interface) + CODESYS V2
PLIO03	I/O module with 20 DI 24VDC, 12 DO 24VDC 0,5 A, 8 Programmable AI, 4 Programmable AO, 1 PT100
PLIO04	I/O Module with 10 DI 24VDC, 10 DO SSR 1.4 A, 4 Programmable AI voltage/PT100/TC, 4 AI voltage, 1 PT100
PLIO06	Compact I/O module. 8 DI, 6 DO, 1 Relay Output
PLIO07	Compact I/O module. 2 Relay Outputs
PLCM03 PLCM04	Plug-in module RS-232 Plug-in module RS-422/485 with optical insulation
PLCM06	Plug-in module Profibus DP slave 12 Mb
PLCM07	Secure Cloud Connector



Sold & Serviced By:



Toll Free Phone (877) SERV098

Toll Free Fax (877) SERV099

www.electromate.com

sales@electromate.com

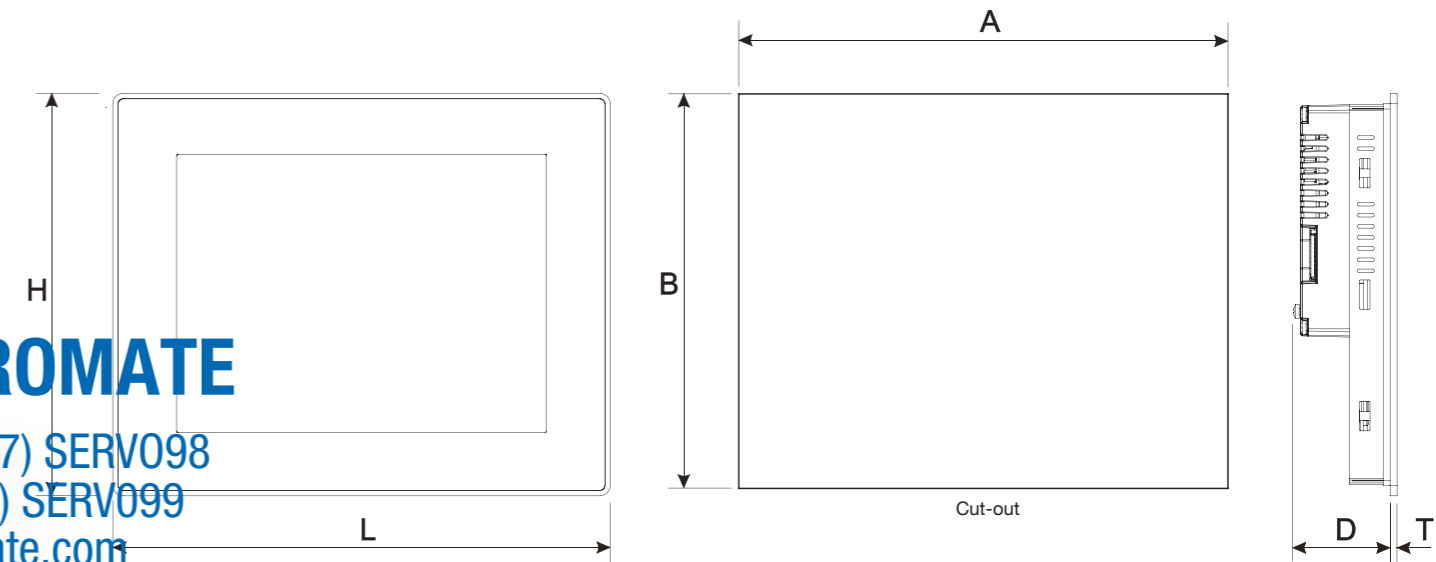

## eTOP Series 500 Glass for HARSH application - No Limits HMI Main Features

- Protection class IP69K
- DNV
- ATEX
- UL Class I. Div 2 Haz. Loc
- Extended temperature range (-20 °C +60 °C)
- Ideal solutions for extreme, outdoor, marine, automotive applications
- Capacitive Touchscreen
- Innovative mechanical design and all-metal enclosure
- Available in different sizes: 7", 10.1" and 15"
- Solutions high performance
- Brilliant displays with LED technology all in full color
- UV Resistant
- High brightness. Readable even in sunlight
- Gateway function, remote installation of application and remote assistance
- Ethernet, USB, serial ports and MPI integrated
- Optional plug-in modules for fieldbus systems and networks
- Support SD Card
- Coating on all Electronic Boards
- Optional IEC 61131-3 integrated PLC (CODESYS V2 or V3)
- Special versions for custom applications



SERIES  
500  
GLASS  
NO LIMITS HMI

Sold & Serviced By:

 **ELECTROMATE**

Toll Free Phone (877) SERV098

Toll Free Fax (877) SERV099

[www.electromate.com](http://www.electromate.com)

[sales@electromate.com](mailto:sales@electromate.com)

**EXOR**  
INTERNATIONAL



	eTOP507G	eTOP507MG	eTOP510G	eTOP515G
Display - Colors	7" TFT 16:9 LED - 64K	7" TFT 16:9 LED - 64K	10.1" TFT 16:9 LED - 64K	15" TFT LED - 64K
Resolution	800x480, WVGA	800x480, WVGA	1280x800, WXGA	1024x768, XGA
Brightness	400 Cd/m <sup>2</sup> typ.	400 Cd/m <sup>2</sup> typ.	600 Cd/m <sup>2</sup> typ.	1500 Cd/m <sup>2</sup> typ.
Dimming	Yes	Yes	Yes	Yes
Touchscreen	True Glass Projected Capacitive	True Glass Projected Capacitive	True Glass Projected Capacitive	True Glass Projected Capacitive
Portrait Mode	Yes	Yes	Yes	Yes
CPU	ARM Cortex-A8 - 600 MHz	ARM Cortex-A8 - 1 GHz	ARM Cortex-A8 - 1 GHz	ARM Cortex-A8 - 1 GHz
User Memory	128 MB Flash	256 MB Flash	256 MB Flash	256 MB Flash
Serial	RS-232, RS-485, RS-422, MPI software configurable	RS-232, RS-485, RS-422, MPI software configurable	RS-232, RS-485, RS-422, MPI software configurable	RS-232, RS-485, RS-422, MPI software configurable
Ethernet	2 10/100 Mbit with integrated Switch	2 10/100 Mbit with integrated Switch	2 10/100 Mbit with integrated Switch	2 10/100 Mbit with integrated Switch
USB	2 Host interfaces (1 version 2.0, 1 version 2.0 and 1.1)	2 Host interfaces (1 version 2.0, 1 version 2.0 and 1.1)	2 Host interfaces (1 version 2.0, 1 version 2.0 and 1.1)	2 Host interfaces (1 version 2.0, 1 version 2.0 and 1.1)
Vector Graphics	Yes, includes SVG support	Yes, includes SVG support	Yes, includes SVG support	Yes, includes SVG support
Object dynamics	Yes	Yes	Yes	Yes
TrueType fonts	Yes	Yes	Yes	Yes
Alarms with historical list	Yes	Yes	Yes	Yes
Recipes and Password	Yes	Yes	Yes	Yes
Trends	Yes	Yes	Yes	Yes
Multilanguage	Yes	Yes	Yes	Yes
Reports	PDF / USB Printer	PDF / USB Printer	PDF / USB Printer	PDF / USB Printer
PDF Reader	Optional	Yes	Yes	Yes
Video Player	No	Yes	Yes	Yes
IP Camera	Frame / Streaming MJPEG	Frame / Streaming MJPEG	Frame / Streaming MJPEG	Frame / Streaming MJPEG
Communication / Gateway	4 protocols	4 protocols	4 protocols	4 protocols
Real Time Clock	Yes, with battery	Yes, with battery	Yes, with battery	Yes, with battery
Battery	Rechargeable Lithium Battery	Rechargeable Lithium Battery	Rechargeable Lithium Battery	Rechargeable Lithium Battery
Expansion Slot	2 Optional Plug-in	2 Optional Plug-in	2 Optional Plug-in	2 Optional Plug-in
Memory card	SD Card Slot	SD Card Slot	SD Card Slot	SD Card Slot
Power Supply	24 Vdc (10 to 32 Vdc)	24 Vdc (10 to 32 Vdc)	24 Vdc (10 to 32 Vdc)	24 Vdc (10 to 32 Vdc)
Current Consumption	0.8A at 24Vdc (max.)	0.9A at 24Vdc (max.)	1.0A at 24Vdc (max.)	1.4A at 24Vdc (max.)
Operating Temperature	-20 to +60 °C	-20 to +60 °C	-20 to +60 °C	-20 to +60 °C
Storage Temperature	-40 to +85 °C	-40 to +85 °C	-20 to +70 °C	-40 to +85 °C
Operating and storage humidity	5 - 85%, RH non-condensing	5 - 85%, RH non-condensing	5 - 85%, RH non-condensing	5 - 85%, RH non-condensing
Weight	Approx. 1.0 Kg	Approx. 1.0 Kg	Approx. 1.7 Kg	Approx. 4.0 Kg
Faceplate (LxH)	187x147 mm	187x147 mm	282x197 mm	392x307 mm
Cut-out (AxB)	176x136 mm	176x136 mm	271x186 mm	381x296 mm
Depth (D+T)	47 + 8 mm	47 + 8 mm	56 + 8 mm	56 + 8.5 mm
Protection Class front / rear	IP69K / IP20	IP69K / IP20	IP69K / IP20	IP69K / IP20
Approvals	CE, DNV, ATEX / cULus Class I, Div. 2 Haz. Loc.	CE, DNV, ATEX / cULus Class I, Div. 2 Haz. Loc.	CE, DNV *, ATEX * / cULus Class I, Div. 2 Haz. Loc. *	CE, DNV, ATEX / cULus Class I, Div. 2 Haz. Loc. *

<b>PLCM01</b> <b>PLCM01-CDS</b> <b>PLCM05-CDS</b>	Plug-in module CAN Plug-in module CAN + CODESYS V2 Plug-in module CODESYS V2
<b>PLCM02</b> <b>PLCM02-CDS</b>	Plug-in module for KNX/EIB (TP interface) Plug-in module for KNX/EIB (TP interface) + CODESYS V2
<b>PLIO03</b>	I/O module with 20 DI 24VDC, 12 DO 24VDC 0.5 A, 8 Programmable AI, 4 Programmable AO, 1 PT100
<b>PLIO04</b>	I/O Module with 10 DI 24VDC, 10 DO SSR 1.4 A, 4 Programmable AI voltage/PT100/TC, 4 AI voltage, 1 PT100
<b>PLIO06</b>	Compact I/O module. 8 DI, 6 DO, 1 Relay Output
<b>PLIO07</b>	Compact I/O module. 2 Relay Outputs
<b>PLCM03</b> <b>PLCM04</b>	Plug-in module RS-232 Plug-in module RS-422/485 with optical insulation
<b>PLCM06</b>	Plug-in module Profibus DP slave 12 Mb
<b>PLCM07</b>	Secure Cloud Connector



Sold & Serviced By:



Toll Free Phone (877) SERV098

Toll Free Fax (877) SERV099

www.electromate.com

sales@electromate.com

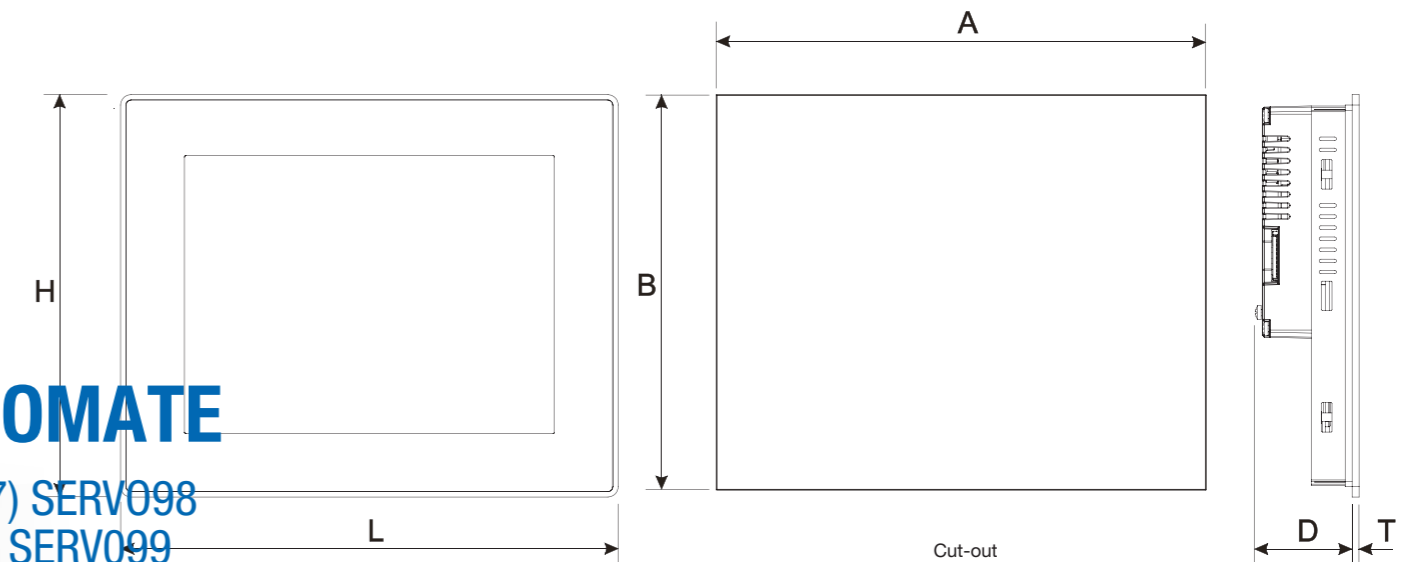

## HMI & PLC + I/O

Here is the ideal solution for powerful and compact applications. Use it in combination with local I/O, available with different options or configure with distributed I/O based on CANopen, Modbus TCP or even Modbus RTU. The PLC includes communication stacks for and an I/O editor that let you easily configure your I/O set-up. The HMI keeps its basic communication capability. Even when running the PLC control program the HMI connects to other PLCs and drives and becomes the perfect tool to improve integration in your control system.

CODESYS version 3 is now the common standard PLC platform for hundreds of controllers in industrial automation and permits, through the use of all the standard languages in IEC programming, an easy and rapid deployment of control applications. The integrated PLC option is available for all eTOP Series 500, Series 600 and eBIS Series 500 products.

The optional plug-in modules are compatible with eTOP Series 500 and Series 600. The excellent price/performance ratio will make it the ideal solution for many of your control projects.



eTOP507 + PLIO03 +  
PLCM01 - CAN  
CODESYS V3 Embedded



eTOP504 + PLIO03 +  
PLCM01 - CAN  
CODESYS V3 Embedded

# HMI + PLC



Sold & Serviced By:



Toll Free Phone (877) SERV098

Toll Free Fax (877) SERV099

[www.electromate.com](http://www.electromate.com)

[sales@electromate.com](mailto:sales@electromate.com)



## eTOP507MFB - Designed for Food and Beverage industry

### Main Features

- Stainless steel bezel 316/1.4401
- IP69K
- Food-compatible gasket
- Food standard sealing compliant with FDA 21 CFR 177.2006
- PCAP touchscreen, can be operated with gloves for food areas
- 7" TFT display 800x480 64K colors
- High-performance 1 GHz ARM CPU with 256 MB Flash
- Designed according to DIN EN1672-2
- Designed according to the EHEDG Guideline
- Extended temperature range (-20°C +60°C)
- 2 Host interface v.2.0, SD Card Slot, 2 Ethernet port with integrated Switch
- Serial port RS-232, RS-485, RS-422, MPI Software configurable
- Ready for integrated CODESYS PLC and I/O

#### CHEMICAL RESISTANCE

Protective front foils is made with high-quality polyester. Polyester withstands exposure of more than 24 hours duration under DIN 42 115 Part 2 to wide range of chemicals without visible change.

Sodium hydroxide 50%  
 Ammonia <32%  
 Sulphuric Acid 30%  
 Acetic acid <50%

IP69K standard	
Water temperature	80°C (176°F)
Pressure	8-10 MPa (80-100 bar) (1160-1450 psi)
Flow rate	14-16 l/m (3.7-4 gal/m)
Nozzle distance	10-15 cm (4-6 inch)
Angles	0° 30° 60° 90°
Timing	30 s/each angle



**eTOP4FOOD**  
 Designed for Food and Beverage industry



Sold & Serviced By:

 **ELECTROMATE**

Toll Free Phone (877) SERV098

Toll Free Fax (877) SERV099

[www.electromate.com](http://www.electromate.com)

[sales@electromate.com](mailto:sales@electromate.com)

**EXOR**  
 INTERNATIONAL

## eTOP Series 500W Open Platform

These are the ideal products when you need for your applications an open platform based on ARM and Windows CE, powerful and rich in features. The result is a combination of the great design of Series 500, its solid construction and, scalability. Direct access to the Windows CE operating system will give you the freedom to program efficiently your application.

You will have the chance to port your existing application to EXOR HMI products with the minimum investment.

Windows CE is an open and stable platform. It is an operating system with limited hardware requirements to offer an high level of performance. The graphical user interface is common to standard Windows making it even simpler to use.

## Technical Data

- Hardware same as Series 500
- Operating System Windows CE 6.0 R3 PRO version
- Internet Explorer
- .NET Compact Framework 3.5
- Driver FTDI
- AYGShell
- Software development kit (SDK) - available on demand.

The Series 500W is the starting point for innovative solutions such as the new VNC Client.

Any Series 500W HMI device becomes an efficient and unexpansive VNC Client. It can be connected to a server running in a PLC, in a computer or even in another HMI device. The VNC client/server technology let you easily create an efficient remote desktop solution to access information in control devices.



SERIES  
**500W**  
OPEN PLATFORM

Sold & Serviced By:

 **ELECTROMATE**

Toll Free Phone (877) SERV098

Toll Free Fax (877) SERV099

[www.electromate.com](http://www.electromate.com)

[sales@electromate.com](mailto:sales@electromate.com)



# SERIES DomiOP

Products for Home Automation

The products of the series DomiOP eBIS500 HMI series combine state-of-the-art features and top performance with an outstanding design. They are the ideal choice for all demanding HMI applications for building automation.

- Flexible control of building for today and tomorrow
- Control of lights, blinds, temperature, heating, etc.
- Scene programming for a more comfortable life
- Designed for wall mounting
- 4.3", 7", 10" up to 13.3" TFT display with 64K colors
- Resistive Touchscreen
- Integrated Ethernet Ports
- Interface KNX TP-optional
- Available in 3 colors (white/black/silver)
- Optional aluminum front cover (for some models)
- USB Ports
- SD memory card
- Certified for residential
- Low energy consumption of energy
- Option boxes for flush mounting in walls and plasterboard
- 5 Year warranty

- Powerful and intuitive programming with JMobile Studio
- Support of a wide range of communication drivers
- Data display as numerical, text, bargraph, analog gauges and graphic image formats
- Data acquisition and trend presentation
- Recipe data handling
- Full support of multilanguage applications
- Powerful script language
- Alarm handling
- User and group access control
- Monitoring and remote control
- Report printing to USB printer
- Optional IEC 61131-3 integrated PLC (CODESYS V2 or V3)
- Rich set of HMI features: dynamic objects, data acquisition, alarm handling, Multilanguage applications, recipes, tag editor and tag database, user and password, scripting...
- Rich symbol library and project templates
- On-line and off-line simulation for applications
- Advanced HMI objects: e-mail, RSS feeds, Scheduler, Rotating menu, IP Video input



# eBIS

Home & Building Automation

Sold & Serviced By:



Toll Free Phone (877) SERV098  
Toll Free Fax (877) SERV099  
[www.electromate.com](http://www.electromate.com)  
[sales@electromate.com](mailto:sales@electromate.com)







	eBIS504	eBIS507	eBIS510	eBIS513
Display - Colors	4.3" TFT 16:9 LED - 64K	7" TFT 16:9 LED - 64K	10"4 TFT LED - 64K	13"3 TFT 16:9 LED - 64K
Resolution	480x272, WQVGA	800x480, WVGA	800x600, SVGA	1280x800, WXGA
Brightness	150 Cd/m <sup>2</sup> typ.	300 Cd/m <sup>2</sup> typ.	300 Cd/m <sup>2</sup> typ.	300 Cd/m <sup>2</sup> typ.
Dimming	Yes	Yes	Yes	Yes
Touchscreen	Resistive	Resistive	Resistive	Resistive
CPU	ARM Cortex-A8 - 600 MHz	ARM Cortex-A8 - 600 MHz	ARM Cortex-A8 - 1 GHz	ARM Cortex-A8 - 1 GHz
User Memory	128 MB Flash	128 MB Flash	256 MB Flash	256 MB Flash
Serial	RS-232, RS-485, RS-422, MPI software configurable	RS-232, RS-485, RS-422, MPI software configurable	RS-232, RS-485, RS-422, MPI software configurable	RS-232, RS-485, RS-422, MPI software configurable
Ethernet	2 10/100 Mbit with integrated Switch	2 10/100 Mbit with integrated Switch	2 10/100 Mbit with integrated Switch	2 10/100 Mbit with integrated Switch
USB	1 Host Interface (v.2.0 and v.1.1)	2 Host Interfaces (1 version 2.0, 1 version 2.0 and 1.1)	2 Host Interfaces (1 version 2.0, 1 version 2.0 and 1.1)	2 Host Interfaces (1 version 2.0, 1 version 2.0 and 1.1)
Vector Graphics	Yes, includes SVG support	Yes, includes SVG support	Yes, includes SVG support	Yes, includes SVG support
Object dynamics	Yes	Yes	Yes	Yes
TrueType fonts	Yes	Yes	Yes	Yes
Alarms with historical list	Yes	Yes	Yes	Yes
Recipes and Password	Yes	Yes	Yes	Yes
Multilanguage	Yes	Yes	Yes	Yes
Reports	PDF / USB Printer	PDF / USB Printer	PDF / USB Printer	PDF / USB Printer
PDF Reader	Optional	Optional	Yes	Yes
Video Player	No	No	Yes	Yes
IP Camera	Frame / Streaming MJPEG	Frame / Streaming MJPEG	Frame / Streaming MJPEG	Frame / Streaming MJPEG
Communication / Gateway	4 protocols	4 protocols	4 protocols	4 protocols
Real Time Clock	Yes, with battery	Yes, with battery	Yes, with battery	Yes, with battery
Battery	Rechargeable Lithium Battery	Rechargeable Lithium Battery	Rechargeable Lithium Battery	Rechargeable Lithium Battery
Expansion Slot	1 Optional Plug-in	2 Optional Plug-in	2 Optional Plug-in	2 Optional Plug-in
Memory card	SD Card Slot	SD Card Slot	SD Card Slot	SD Card Slot
Power Supply	24 Vdc (10 to 32 Vdc)	24 Vdc (10 to 32 Vdc)	24 Vdc (10 to 32 Vdc)	24 Vdc (10 to 32 Vdc)
Current Consumption	0.4A at 24 VDC (max.)	0.7A at 24 VDC (max.)	1A at 24 VDC (max.)	1.2A at 24 VDC (max.)
Operating Temperature	5 to 40 °C	5 to 40 °C	5 to 40 °C	5 to 40 °C
Storage Temperature	-20 to +70 °C	-20 to +70 °C	-20 to +70 °C	-20 to +70 °C
Operating and storage humidity	5 - 85%, RH non-condensing	5 - 85%, RH non-condensing	5 - 85%, RH non-condensing	5 - 85%, RH non-condensing
Weight	Approx 1.0 Kg	Approx 1.0 Kg	Approx 2.1 Kg	Approx 2.8 Kg
Faceplate (LxH)	147x107 mm (5.78x4.21")	187x147 mm (7.36x5.79")	287x232 mm (11.3x9.13")	336x267 mm (13.22x10.51")
Cut-out (AxB)	136x96 mm (5.35x3.78")	176x136 mm (6.93x5.35")	276x221 mm (10.86x8.70")	326x256 mm (12.83x10.07")
Depth (D+T)	56 + 4 mm (2.20+0.16")	47+4 mm (1.85+0.16")	56+4 mm (2.20+0.16")	56+4 mm (2.20+0.16")
Protection Class front / rear	IP20	IP20	IP20	IP20
Approvals	EN 50090-2-2 + EN 50090-2-2/A1+EN 50090-2-2/A2 Immunity EN 61000-6-1, Emission EN 61000-6-3 for installation in residential environments	EN 50090-2-2 + EN 50090-2-2/A1+EN 50090-2-2/A2 Immunity EN 61000-6-1, Emission EN 61000-6-3 for installation in residential environments	EN 50090-2-2 + EN 50090-2-2/A1+EN 50090-2-2/A2 Immunity EN 61000-6-1, Emission EN 61000-6-3 for installation in residential environments	EN 50090-2-2 + EN 50090-2-2/A1+EN 50090-2-2/A2 Immunity EN 61000-6-1, Emission EN 61000-6-3 for installation in residential environments

PLCM02

Plug-in module for KNX/EIB (TP interface)

PLCM02- CDS

Plug-in module for KNX/EIB (TP interface) + CODESYS V2



Sold & Serviced By:  
**ELECTROMATE**

Toll Free Phone (877) SERV098

Toll Free Fax (877) SERV099

www.electromate.com

sales@electromate.com

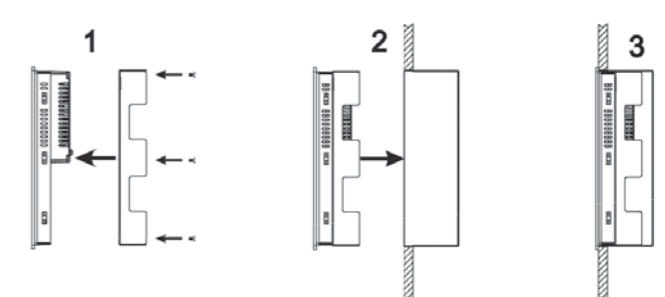

Wall Mounting - eBIS504-507

Wall Mounting - eBIS510-513

## eSMART Series– Designed for budget critical applications

### Main Features

- Display Size 4.3", 7" and 10.1"
- Widescreen Display
- Resistive Touchscreen
- Brilliant Display with LED Backlight
- Ethernet, USB and Serial Port
- Lightweight and low-power design
- Highly Reliable, Industrial Grade Components
- CE, cULus approval

### eSMART products for budget-critical applications

- Powerful and intuitive programming with JMobile Studio
- Support of a wide range of communication drivers
- Data display as numerical, text, bargraph, analog gauges and graphic image formats
- Data acquisition and trend presentation
- Recipe data handling
- Full support of multilanguage applications
- Powerful script language
- Alarm handling
- User and group access control
- Monitoring and remote control
- Rich set of HMI features: dynamic objects, data acquisition, alarm handling, multilanguage applications, recipes, tag editor and tag database, user and password, scripting ...
- Rich symbol library and project templates
- On-line and off-line Simulation for applications
- Advanced HMI objects: e-mail, RSS feeds, Scheduler, Rotating menu, IP Video input



# eSMART SERIES

DESIGNED FOR BUDGET CRITICAL APPLICATIONS

Sold & Serviced By:



Toll Free Phone (877) SERV098  
Toll Free Fax (877) SERV099  
[www.electromate.com](http://www.electromate.com)  
[sales@electromate.com](mailto:sales@electromate.com)

# eSMART SERIES



	eSMART04	eSMART07M	eSMART10
Display	4.3" TFT 16:9	7" TFT 16:9	10.1" TFT 16:9
Resolution	480x272	800x480	1024x600
Backlight	LED	LED	LED
Brightness	200 Cd/m <sup>2</sup> typ	200 Cd/m <sup>2</sup> typ	200 Cd/m <sup>2</sup> typ
Dimming	Yes	Yes	Yes
Colors	64K	64K	64K
Touchscreen	Resistive	Resistive	Resistive
Portrait Mode	Yes	Yes	Yes
CPU	ARM Cortex A8 300 MHz	ARM Cortex A8 1 GHz	ARM Cortex A8 1 GHz
RAM	256 MB	512 MB	512 MB
Flash	2 GB	4 GB	4 GB
Application Memory	60 MB	60 MB	60 MB
Serial	RS-232, RS-485, RS-422, software configurable	RS-232, RS-485, RS-422, software configurable	RS-232, RS-485, RS-422, software configurable
Ethernet	10/100 Mbit	10/100 Mbit	10/100 Mbit
USB	1x Host (V2.0, max. 500 mA)	1x Host (V2.0, max. 500 mA)	1x Host (V2.0, max. 500 mA)
Vector graphics	Yes, includes SVG support	Yes, includes SVG support	Yes, includes SVG support
Object dynamics	Yes	Yes	Yes
TrueType fonts	Yes	Yes	Yes
Alarms	Yes	Yes	Yes
Historical Event List	Yes	Yes	Yes
Recipes	Yes	Yes	Yes
Password	Yes	Yes	Yes
Trends	Yes	Yes	Yes
Multilanguage	Yes	Yes	Yes
RTC	Supercapacitor	Supercapacitor	Supercapacitor
Power Supply	24 Vdc (18 to 32 Vdc)	24 Vdc (18 to 32 Vdc)	24 Vdc (18 to 32 Vdc)
Current Consumption	0.25 A max. at 24Vdc	0.3 A at 24Vdc (max.)	0.38 A at 24Vdc(max.)
Operating Temperature	0 to 50 °C	0 to 50 °C	0 to 50 °C
Storage Temperature	-20 to +70 °C	-20 to +70 °C	-20 to +70 °C
Operating and storage humidity	5 - 85%, RH non condensing	5 - 85%, RH non condensing	5 - 85%, RH non condensing
Weight	Approx 0.4 Kg	Approx 0.6 Kg	Approx 1.0 Kg
Faceplate (LxH)	147x107 mm	187x147 mm	282x197 mm
Cutout (AxB)	136x96 mm	176x136 mm	271x186 mm
Depth (D+T)	29 + 5 mm	29 + 5 mm	29 + 5 mm
Protection Class (front)	IP66, Type 2 and 4X	IP66, Type 2 and 4X	IP66, Type 2 and 4X
Protection Class (rear)	IP20	IP20	IP20
Approvals	CE, cULus	CE, cULus	CE, cULus



Sold & Serviced By:



Toll Free Phone (877) SERV098

Toll Free Fax (877) SERV099

[www.electromate.com](http://www.electromate.com)

[sales@electromate.com](mailto:sales@electromate.com)

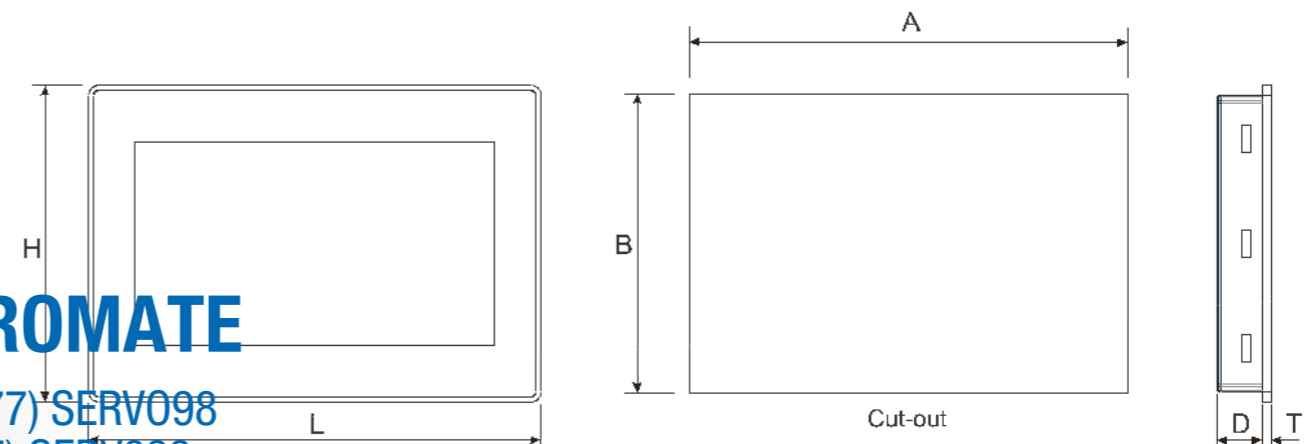

## ON3 Handheld - Mobile HMI Solutions

### Main Features

- Handheld HMI device with Safety Functions
- Compact and Lightweight
- Ergonomic design
- Programming tool "Drag&Drop"
- High reliability from industrial grade components
- Create user interfaces for all application areas
- Supports a great number of communication protocols
- Resistive touchscreen and keypad with tactile feedback
- USB Ports
- Emergency Stop button and 3-position Enabling Switch
- Integrated Handwheel, available as option
- Integrated 16-position selector and potentiometers
- Connection box, available as option
- Device Holder, available as option
- Cable length 5, 10, 20 meters
- Low Power Consumption
- Extended sales and support network

ON3 is an independent brand company specialized in safety products for Factory Automation.

ON3 handhelds are engineered and supported by Exor International S.p.A.

For further information:  
[www.0n3.eu](http://www.0n3.eu)



**ON3**  
safety&controls

Sold & Serviced By:

 **ELECTROMATE**

Toll Free Phone (877) SERV098

Toll Free Fax (877) SERV099

[www.electromate.com](http://www.electromate.com)

[sales@electromate.com](mailto:sales@electromate.com)

**EXOR**  
INTERNATIONAL

## eTOP Series 300 - Solid as a Rock

### Main Features

- 5 Year Warranty
- Elegant and robust all-metal design
- Analog resistive touch screen
- Brilliant displays with LED technology
- Gateway function, remote installation of application and remote assistance
- Ethernet, USB host ports and serial integrated
- Optional plug-in modules for fieldbus systems and networks
- Optional IEC 61131-3 Soft PLC (CODESYS V2)
- Front available in three colors (White/Black/Silver)

### Step into the future with an eye on the past

- Programming via Designer software, already used in the Legacy Series
- Support for a full range of communication drivers for all types of PLC
- Display data in numerical form, bar, for analog gauges and images
- Data acquisition and trend visualization
- Recipe data storage
- Multilingual Applications
- Password
- Alarm handling
- Remote monitoring and control
- Report printing to USB printer
- Optional IEC 61131-3 Soft PLC (CODESYS V2)
- Rich symbol library



SERIES  
300  
SOLID AS A ROCK

Sold & Serviced By:

 **ELECTROMATE**

Toll Free Phone (877) SERV098

Toll Free Fax (877) SERV099

[www.electromate.com](http://www.electromate.com)

[sales@electromate.com](mailto:sales@electromate.com)

**EXOR**  
INTERNATIONAL

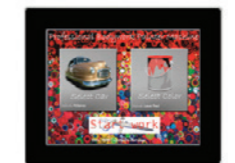

	eTOP306	eTOP307	eTOP310	eTOP312
Display - Colors	5.7" TFT LED - 64K	7" TFT 16:9 LED - 64K	10"4 TFT LED - 64K	12"1 TFT LED - 64K
Resolution	320x240, QVGA	800x480, WVGA	640x480, VGA	800x600, SVGA
Dimming	Yes	Yes	Yes	Yes
Touchscreen	Resistive	Resistive	Resistive	Resistive
User Memory	64 MB Flash	64 MB Flash	64 MB Flash	64 MB Flash
Serial	RS-232, RS-485, RS-422, software configurable	RS-232, RS-485, RS-422, software configurable	RS-232, RS-485, RS-422, software configurable	RS-232, RS-485, RS-422, software configurable
Ethernet	10/100 Mbit	10/100 Mbit	10/100 Mbit	10/100 Mbit
USB	Host interface version 1.1	Host interface version 1.1	Host interface version 1.1	Host interface version 1.1
TrueType fonts	Yes	Yes	Yes	Yes
Alarms with historical list	Yes	Yes	Yes	Yes
Recipes and Password	Yes	Yes	Yes	Yes
Multilanguage	Yes	Yes	Yes	Yes
Real Time Clock	Yes, with battery	Yes, with battery	Yes, with battery	Yes, with battery
Battery	Rechargeable Lithium Battery	Rechargeable Lithium Battery	Rechargeable Lithium Battery	Rechargeable Lithium Battery
Power Supply	24 Vdc (18 to 30 Vdc)	24 Vdc (18 to 30 Vdc)	24 Vdc (18 to 30 Vdc)	24 Vdc (18 to 30 Vdc)
Current Consumption	0.55A at 24Vdc (max.)	0.6A at 24Vdc (max.)	0.8A at 24Vdc (max.)	1.0A at 24Vdc (max.)
Operating Temperature	0 to 50 °C	0 to 50 °C	0 to 50 °C	0 to 50 °C
Storage Temperature	-20 to +70 °C	-20 to +70 °C	-20 to +70 °C	-20 to +70 °C
Operating and storage humidity	5 - 85%, RH non-condensing	5 - 85%, RH non-condensing	5 - 85%, RH non-condensing	5 - 85%, RH non-condensing
Weight	Approx. 1.0 Kg	Approx. 1.0 Kg	Approx. 2.1 Kg	Approx. 2.8 Kg
Faceplate (LxH)	187x147 mm	187x147 mm	287x232 mm	336x267 mm
Cut-out (AxH)	176x136 mm	176x136 mm	276x221 mm	326x256 mm
Depth (D+T)	45 + 4 mm	45 + 4 mm	42 + 4 mm	42 + 4 mm
Protection Class front / rear	IP65 / IP20	IP65 / IP20	IP65 / IP20	IP65 / IP20
Approvals	CE / cULus Class I, Div. 2	CE / cULus	CE / cULus Class I, Div. 2	CE / cULus Class I, Div. 2

TCM01  
TCM02  
TCM03  
TCM07  
TCM08  
TCM09

Add-on module for Siemens MPI (S7 300-400)  
Add-on module for Moeller Suconet K  
Add-on module for DeviceNet  
Add-on module for Siemens MPI (S7 300-400), without optoisolation  
Add-on module for Profibus DP slave 12 Mb  
Add-on module for CANopen

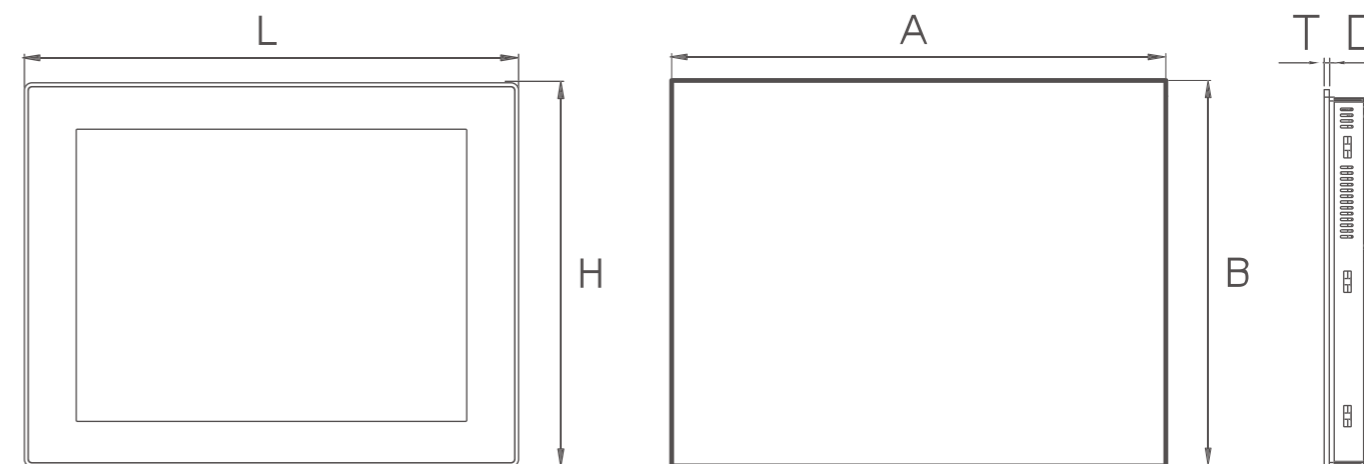

Cut-out

Sold & Serviced By:



Toll Free Phone (877) SERV098

Toll Free Fax (877) SERV099

www.electromate.com

sales@electromate.com

## Key Operated and Legacy Products

The UniOP family, currently available in over 100 different models, is presented with a range of HMI devices easily programmable with the Designer software configuration.

This allows both the complete adaptability with varied industrial equipment in different application fields and a substantial reduction in cost for the creation of applications and their maintenance.

- Programming via Designer software
- Support for a full range of communication drivers for all types of PLC
- Display data in numerical form, bar, for analog gauges and images
- Data acquisition and trend visualization
- Recipe data storage
- Multilingual Applications
- Password
- Alarm handling
- Remote monitoring and control
- Report printing to USB printer
- Optional IEC 61131-3 Soft PLC (CODESYS V2)
- Rich symbol library



SERIES  
UniOP

Sold & Serviced By:

 **ELECTROMATE**

Toll Free Phone (877) SERV098

Toll Free Fax (877) SERV099

[www.electromate.com](http://www.electromate.com)

[sales@electromate.com](mailto:sales@electromate.com)

**EXOR**  
INTERNATIONAL



		ePALM10	ePAD03 / ePAD04	ePAD05 / ePAD06	CP10G-04	eTOP03	eTOP04C	eTOP05	
Display:	Type	LCD	LCD	LCD	LCD	LCD monochrome	TFT Color	LCD monochrome	
	Colors	-	-	-	-	-	256	-	
	Diagonal	-	-	-	-	3.8"	4.3"	5.7"	
	Lines x Characters	8 x 20	4 x 20	4 x 20	4 x 20	-	-	-	
	Resolution	120 x 64	120 x 32	120 x 32	120 x 32	320 x 240	480 x 272	320 x 240	
	Dimming	-	-	-	-	-	Yes	-	
Operator Interface	Touchscreen	-	-	-	-	Yes	Yes	Yes	
	Function Keys	9	4	9	12	-	-	-	
	System Keys	18	6	10	23	-	-	-	
	Numerical Keys	Yes	-	Yes	Yes	-	-	-	
	LED indicators	20	5	10	13	-	-	-	
Memory	User Memory	512KB	512 KB	512KB	512KB	512KB	2 MB	32 MB	
	Flash Card option	-	-	-	-	-	-	Yes	
	Recipe Memory	16KB	16KB / -	16KB / -	16KB	32KB	32 KB	32KB	
Interfaces	PLC port	RS-232, RS-485	RS-232, RS-485	RS-232, RS-485	RS-232, RS-485	RS-232, RS-485	RS-232, RS-485	RS-232, RS-485	
	Programming/Printer port	Yes	-	-	Yes	-	-	Yes	
	UniNet (server and client)	Yes	client	Yes	Yes	Yes	Yes	Yes	
	Aux port	Yes	Yes	Yes	Yes	Yes	Yes	Yes	
	Ethernet port	-	-	-	-	-	Yes	-	
	USB port	-	-	-	-	-	Yes	-	
	Video Input option	-	-	-	-	-	-	-	
Communication	200 drivers, 11 fieldbuses	Yes	Yes	Yes	Yes	Yes	Yes	Yes	
	Dual driver	Yes	Yes	Yes	Yes	Yes	Yes	Yes	
Features	Graphic	Yes	Yes	Yes	Yes	Yes	Yes	Yes	
	Vector graphics	-	-	-	-	-	Yes	-	
	TrueType font support	-	-	-	-	-	-	-	
	Trend acquisition	-	-	-	-	-	-	Yes	
	Battery	Yes	Yes / -	Yes / -	Yes	Yes	Yes	Yes	
	Real Time Clock	Yes	Yes / -	Yes / -	Yes	Yes	Yes	Yes	
	Password	Yes	Yes	Yes	Yes	Yes	Yes	Yes	
	Alarms	1024	1024	1024	1024	1024	1024	1024	
	Event list	256	256 / -	256 / -	256	256	256	1024	
	Voltage	18-30 VDC	18-30 VDC	18-30 VDC	18-30 VDC	18-30 VDC	18-30 VDC	18-30 VDC	
	Current rating	0.3 A	0.25 A	0.25 A	0.3 A	0.4 A	0.4 A	0.6 A	
	Environment	Protection Class	IP65	IP65, NEMA 4X	IP65, NEMA 4X	IP65, NEMA 4X	IP65, NEMA 4X	IP65, NEMA 4X	IP65, NEMA 4X
		Temperature range	0 – 50 °C	0 – 50°C	0 – 50°C	0 – 50°C	0 – 50°C	0 – 50°C	0 – 50°C
Dimensions	Faceplate (LxH)	116x239	149x109	149x109	141x176	149x109	149 x109	187x147	
	Cut-out (AxB)	Handheld wired (5 - 10 mt)	136x96	136x96	128x163	136x96	136x96	176x136	
	Depth (D+T)	-	50 + 5 mm	50 + 5 mm	75 + 5 mm	61 + 5 mm	56 + 5 mm	67 + 4 mm	
	Weight	0,5 Kg	1 Kg	1 Kg	1.1 Kg	1 Kg	1 Kg	1.4 Kg	
Approvals		CE, UL	CE, UL	CE, UL	CE, UL	CE, UL	CE, UL	CE, UL	
Programming		Designer 6	Designer 6	Designer 6	Designer 6	Designer 6	Designer 6	Designer 6	

TCM01  
TCM02  
TCM03  
TCM07  
TCM08  
TCM09

Add-on module for Siemens MPI (S7 300-400)  
Add-on module for Moeller Suconet K  
Add-on module for DeviceNet  
Add-on module for Siemens MPI (S7 300-400), without optoisolation  
Add-on module for Profibus DP slave 12 Mb  
Add-on module for CANopen



Sold & Serviced By:



Toll Free Phone (877) SERV098

Toll Free Fax (877) SERV099

www.electromate.com

sales@electromate.com

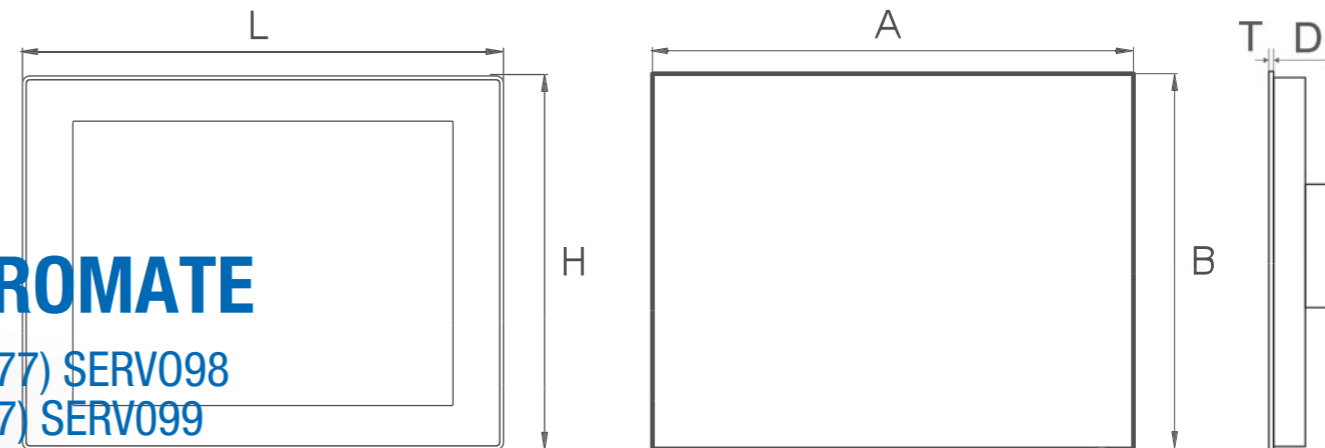

Cut-out



## iPC - Products for PC-based automation

EXOR International offers a complete range of fanless computers dedicated to automation.

All products are available in wide and flexible range of configurations. You will have the product that fit your needs.

All products have a robust mechanical construction that will suit the most demanding applications.

The catalog includes a wide choice of:

- Panel PC
- Box PC
- Panel Monitor

Products can be configured with different choice of CPU, RAM, disk and operating systems.

PC offered by EXOR International are the ideal platform for running applications based on JMobile PC Runtime.

An application integrating HMI on a powerful hardware platform is ready in all cases where the embedded HMIs do not meet all requirements.

You will find detailed and up-to-date information on PC products in our web site [www.exorint.net](http://www.exorint.net)



# iPC

Sold & Serviced By:

 **ELECTROMATE**

Toll Free Phone (877) SERV098

Toll Free Fax (877) SERV099

[www.electromate.com](http://www.electromate.com)

[sales@electromate.com](mailto:sales@electromate.com)

**EXOR**  
INTERNATIONAL



6 continents  
5 branches  
More than 30 distributors

*Wherever, Together, Forever*  
Exor International, your global partner  
[www.exorint.net/partners.html](http://www.exorint.net/partners.html)

**EXOR**  
INTERNATIONAL

Sold & Serviced By:

 **ELECTROMATE**

Toll Free Phone (877) SERV098

Toll Free Fax (877) SERV099

[www.electromate.com](http://www.electromate.com)

[sales@electromate.com](mailto:sales@electromate.com)

Exor reserves the right to make changes in the specifications of its proprietary products at any time without notice.