

# EADmotors: High-Performance Solutions

## EADmotors

Since 1942, EADmotors has been manufacturing high-performance rotating products for industry.

We have broad experience designing and producing motors, blowers, and fans that meet extremely precise engineering requirements. We are capable of solving difficult design problems involving motion technology.

## Achieving Your Goals

If your company is involved in producing high-performance products such as instruments, satellite tracking systems, control products, etc., EADmotors can provide valuable help. We believe the key to achieving your performance goals is working together. With our strong engineering capabilities, we can work with you to develop precision motion products to meet your most exacting requirements.

## Quick Delivery for Custom Products

EADmotors specializes in meeting individual customer requirements. We have developed the ability to quickly design and manufacture custom products and modified standards. Typical examples of the type of modifications we do every day are:

- Connectors
- Shielded cables
- Special shafts
- Custom end caps and mounting configurations
- Custom windings to optimize performance
- Special packaging for harsh environments
- Precision tolerances

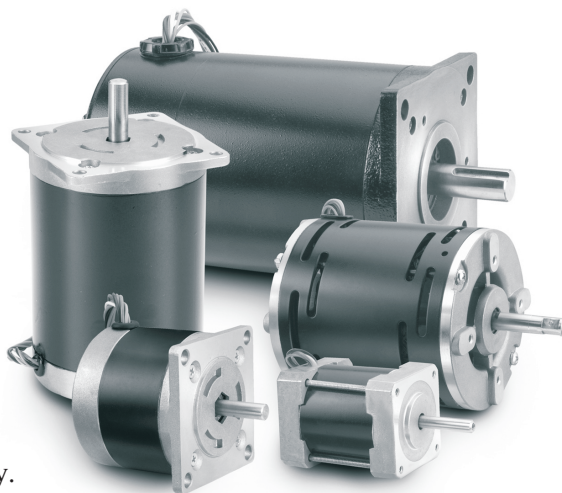

## Brushless DC Servo Motors

EADmotors offers a full line of brushless DC servo motors from sizes 17 through 42. Our servo motors feature high energy neodymium magnets for high torque in a compact package. EAD servo motors offer high speed and extremely smooth and precise motion. They are fully compatible with industry standard analog and digital servo amplifiers. Our servo motors operate at high speed and provide extremely smooth and precise motion when stepping motor technology has reached its limits.

- NEMA standard size 17, 23, 34, and 42 mechanical designs
- Optical encoders (optional)
- High speed, smooth operation
- Cost-effective designs for OEM applications
- Industry-standard, 3-phase designs
- Windings available to match any servo-amplifier
- Output power to 1000 Watts (peak)
- Available with custom shaft, end caps, cables, and connectors

Typical applications include high speed inspection systems, semiconductor handling equipment, document sorting equipment, and medical systems.

## Table of Contents

Solutions to Problems ....	2
Other Products in Motion .....	2
Brushless DC Servo Motors	
NEMA 17 .....	4
NEMA 23 .....	6
NEMA 34 .....	8
NEMA 42 .....	10
Open Frame Brushless DC Motor	
Size 39.....	12
Miniature Brushless DC Motors.....	13
High Performance Encoder.....	14
Low Profile Encoder.....	15
Connection Diagram ....	16

# Solutions to Problems

Think of EADmotors as the company that gives you solutions. We are capable of supplying auxiliary components and hardware to improve the performance and profitability of your products. We'd like to be a member of your team, working with you to produce products of the highest quality at minimum cost.

## Other Products in Motion

### Linear Actuators

EADmotors digital linear actuators are based on modified hybrid stepping motors that incorporate an integral nut assembly and precision lead screw design. They are extremely reliable devices that provide a simple and efficient method of creating a linear positioning system. EADmotors linear actuators are available in a variety of sizes from 17 through 42 frame. These precision devices are capable of producing a linear force of up to 700 pounds and resolution up to 0.000125" per 1.8° step.

Conventional designs feature internal rotating nuts made from SAE 660 bearing bronze. The *DuraPlus* series, available in both the L1 and L2 frames, features a precision stainless steel shaft with low friction internal nuts made of a variety of engineered polymers. The *DuraPlus* series is the latest advance in integrated linear motion yielding both long life and smooth, quiet operation.

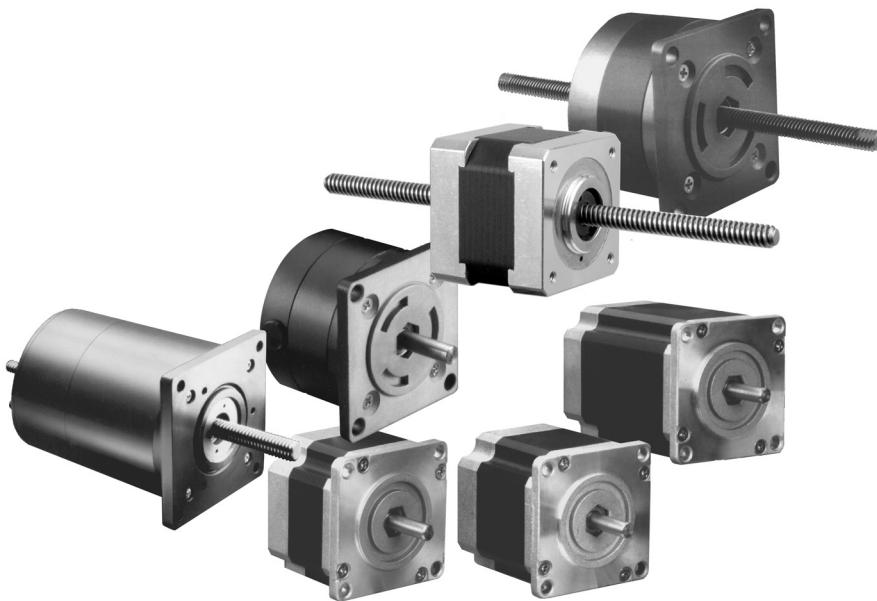

### Stepping Motors

For over 25 years, EADmotors has designed stepping motors for a wide range of applications. EAD stepping motors have been used on a variety of products in diverse applications such as packaging, semiconductor handling and testing, antenna positioning, laboratory equipment, and even electric braking systems for railway cars. EAD stepping motors are known throughout the industry for high quality, long life, and unparalleled consistency.

### Centrifugal Blowers

EADmotors centrifugal blowers are known for quiet, reliable operation. Made in single, double, and inverted styles, they deliver up to 600 CFM airflow. The AC blowers have near-constant speed permanent split capacitor motors. Brushless DC models operate at fixed or variable speed.

### Axial Fans

EADmotors manufactures a broad line of vane axial, tube axial, and axial fans. They encompass a wide range of air volumes at low to relatively high pressures. Designed for maximum efficiency at minimum input, these high-performance fans offer exceptionally long life and reliability. Quiet, smooth-running ball bearings eliminate the need for maintenance and lubrication.

Solutions in motion

**EAD**<sup>TM</sup> **motors**  
 Eastern Air Devices Inc.

## Other Products in Motion

### Synchronous Motors

Synchronous motors run at an exact speed. The speed will not vary with load or voltage. We make hysteresis and reluctance types in a wide range of frame sizes. EAD hysteresis-synchronous motors develop smooth, constant starting and accelerating torques. They synchronize any load within their torque rating—regardless of inertia.

EAD reluctance-synchronous motors function at constant speeds—and cost very little more than standard induction motors.

### Induction Motors

In single and 3-phase models, EAD induction motors are designed for a wide range of commercial and military applications. For low starting torque applications, permanent-split capacitor types offer higher efficiency and a higher power factor than other designs. Capacitor start and split phase motors are used when a high starting torque is required. EADmotors manufactures both high and low slip permanent split capacitor motors to meet a wide range of application requirements.

### Torque Motors

Torque motors are commonly used where prolonged stalled operation or special running-torque characteristics are required. They may involve either static or dynamic forces.

Applications may require smooth, moderate accelerating torque and low speed with speed ranges from near synchronous to zero.

### Stator/Rotor Sets

EADmotors provides frameless versions of all of our designs. Stator/rotor sets offer the advantage of eliminating component parts in a system such as redundant bearings and couplings. They also allow systems to be smaller and more reliable as possible failure modes are eliminated at the design stage. Contact us for more information about how stator/rotor sets can make your products more competitive.

In addition to brushless DC motors, EADmotors manufactures a wide range of other types of motors and controls as well as blowers and fans.



**SIZE**  
**17**

# NEMA 17 Brushless DC Servo Motor

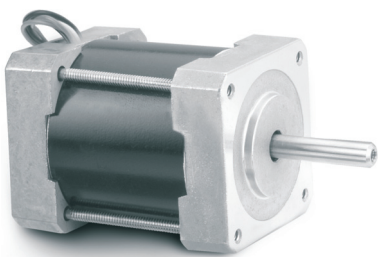

## Features

- No brushes or commutator
- Ball bearing construction
- Dynamically balanced rotors
- Low audible and magnetic noise
- High-speed operation
- Compatible with all three-phase brushless DC motor amplifiers

## Typical Applications

- Centrifuges
- Bar code readers
- Film transport
- Machine tools
- Robotics
- Semiconductor equipment
- Gyroscopes
- Conveyors
- Paper feed
- X-Y positioning
- Light industrial

## Electrical Ratings

Parameter	Symbol	Units	DB17EDB	DB17FDB	DB17GDB
Cont. Stall Torque <sup>1</sup>	T <sub>C</sub>	oz-in N-m	7.5 0.05	8 0.06	10 0.07
Peak Torque <sup>2</sup>	T <sub>P</sub>	oz-in N-m	18 0.13	26 0.18	33 0.23
Motor Constant	K <sub>M</sub>	oz-in/ $\sqrt{\text{watt}}$ N-m/ $\sqrt{\text{watt}}$	1.9 0.013	2.5 0.017	3.1 0.022
Elec. Time Constant	$\tau_E$	msec	0.22	0.24	0.29
Mech. Time Constant	$\tau_M$	msec	9.09	6.64	5.14
Rotor Inertia	J	oz-in-sec <sup>2</sup> gm-cm <sup>2</sup>	0.00028 19.8	.00035 24.7	.00042 29.7
Thermal Resistance	R <sub>TH</sub>	°C/watt	6.0	5.8	5.6
Weight	W	oz Kg	9 0.25	11 0.31	13 0.36
Motor Length	L	inch mm	2.4 61.0	2.7 68.6	3.0 76.2
# of Poles	—	—	8	8	8

## Winding Data

Parameter	Symbol	Units	DB17EDB				DB17FDB				DB17GDB			
			-10	-11	-12	-13	-10	-11	-12	-13	-10	-11	-12	-13
Design Voltage	V	volts	24	48	90	160	24	48	90	160	24	48	90	160
Cont. Stall Current <sup>1</sup>	I <sub>C</sub>	amperes	1.4	0.7	0.4	0.2	1.5	0.8	0.4	0.2	1.7	0.8	0.4	0.2
Peak Current <sup>2</sup>	I <sub>P</sub>	amperes	3.6	1.9	1.1	.6	4.4	2.3	1.4	.8	4.7	2.6	1.5	.9
Voltage Constant ±10%	K <sub>E</sub>	V/kRPM V/rad/sec	3.7 0.035	6.8 0.065	12.2 0.117	20.7 0.198	4.4 0.042	8.2 0.078	14.1 0.134	24.0 0.230	5.2 0.049	9.5 0.090	16.6 0.159	27.7 0.265
Torque Constant ±10%	K <sub>T</sub>	oz-in/amp N-m/amp	5.0 0.035	9.3 0.065	16.5 0.116	28.0 0.198	5.9 0.042	11.1 0.078	19 0.134	32.5 0.229	7.0 0.049	12.8 0.090	22.5 0.159	37.5 0.265
Resistance ±10%	R <sub>M</sub>	Ohms	6.9	23.7	75.4	217.0	5.8	19.4	57.8	169.0	5.1	17.1	52.7	146.3
Inductance ±30%	L <sub>M</sub>	mH	1.3	8.0	13.9	40.1	1.3	4.7	13.8	40.5	1.5	5.0	15.5	43.1

**NOTES:** Motors are available with different windings and mechanical modifications to meet specific applications. Contact the factory for technical and engineering assistance.

<sup>1</sup> Continuous rating based on 25°C ambient temperature, winding temperature rise of 100°C and motor mounted to a 6x6x¼ inch aluminum heat sink.

<sup>2</sup> 10 second at 25° C ambient, 100°C winding temperature.

<sup>3</sup> Inductance bridge measurement method @ 1kHz.

Solutions in motion

**EAD**<sup>TM</sup> **motors**  
Eastern Air Devices Inc.



# NEMA 17 Brushless DC Servo Motor

SIZE  
17

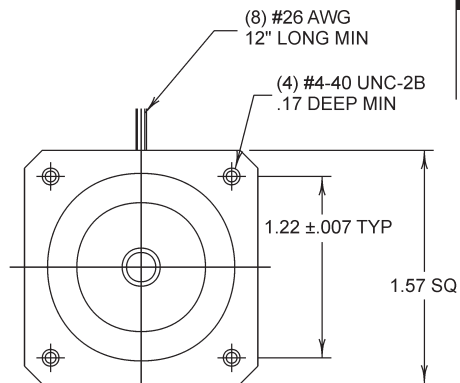
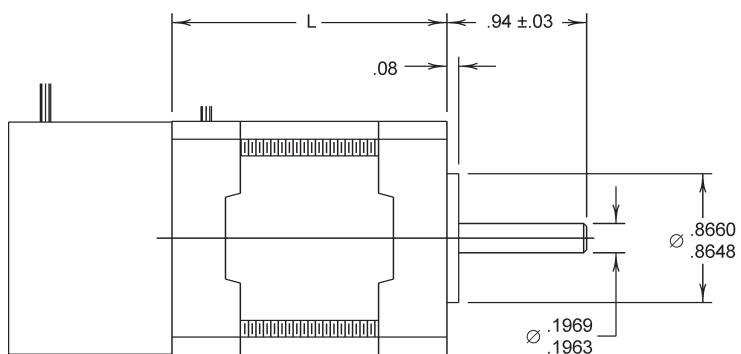

Optional Encoder  
(see pages 14 and 15)

## Size 17

Model Series	Dimension "L"
DB17EDB	2.4 in (61.0 mm)
DB17FDB	2.7 in (68.6 mm)
DB17GDB	3.0 in (76.2 mm)

See page 16 for Connection Diagrams.

## Pullout Torque Speed Curves

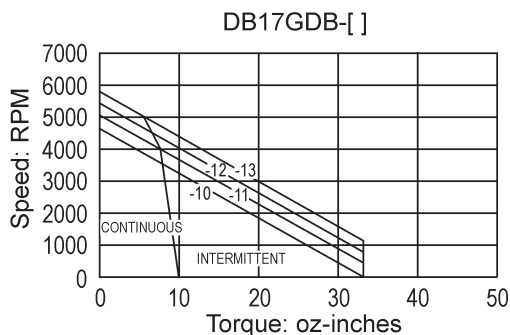
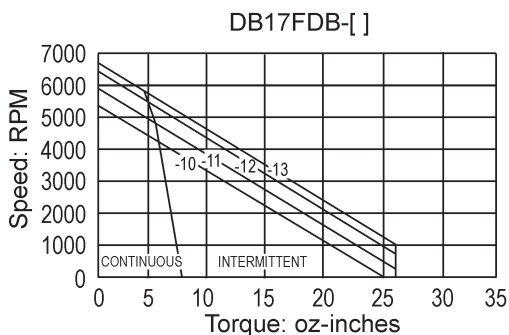
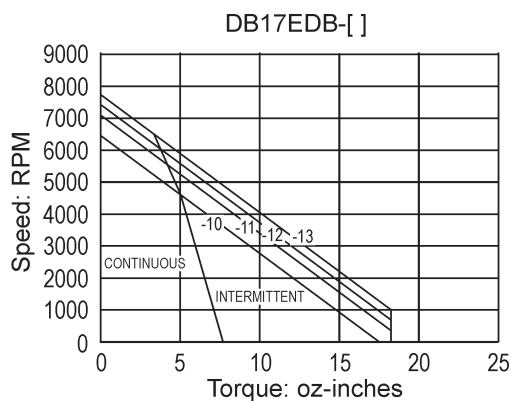

SIZE  
**23**

# NEMA 23 Brushless DC Servo Motor

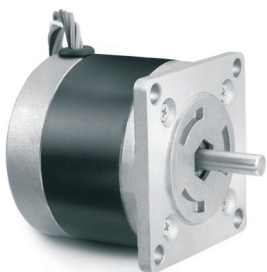

## Features

- No brushes or commutator
- Ball bearing construction
- Dynamically balanced rotors
- Low audible and magnetic noise
- High-speed operation
- Compatible with all three-phase brushless DC motor amplifiers

## Typical Applications

- Centrifuges
- Bar code readers
- Film transport
- Machine tools
- Robotics
- Semiconductor equipment
- Gyroscopes
- Conveyors
- Paper feed
- X-Y positioning
- Light industrial

## Electrical Ratings

Parameter	Symbol	Units	DA23BBB	DA23DBB	DA23GBB	DA23JBB
Cont. Stall Torque <sup>1</sup>	T <sub>C</sub>	oz-in (N-m)	26.4 (0.19)	34 (0.24)	54 (0.38)	73 (0.52)
Peak Torque <sup>2</sup>	T <sub>P</sub>	oz-in (N-m)	50 (0.35)	80 (0.56)	150 (1.06)	190 (1.34)
Motor Constant	K <sub>M</sub>	oz-in/√watt N-m/√watt	4.5 0.03	6.6 0.05	9.2 0.06	15 0.11
Elec. Time Constant	τ <sub>E</sub>	msec	1.24	1.3	1.54	1.62
Mech. Time Constant	τ <sub>M</sub>	msec	9.06	9.212	6.24	5.41
Rotor Inertia	J	oz-in-sec <sup>2</sup> gm-cm <sup>2</sup>	0.00152 107.3	0.00286 202	0.0047 331.9	0.00715 504.9
Thermal Resistance	R <sub>TH</sub>	°C/watt	3.2	3.01	2.82	2.7
Weight	W	oz (Kg)	15 (0.425)	21 (0.59)	31 (0.87)	47 (1.32)
# of Poles	—	—	4	4	4	4

## Winding Data

Parameter	Symbol	Units	DA23BBB				DA23DBB			
			-M100	-M200	-M300	-M400	-M100	-M200	-M300	-M400
Design Voltage	V	Volts DC	12	24	48	90	12	24	48	160
Cont. Stall Current <sup>1</sup>	I <sub>C</sub>	amperes	5.3	4.64	2.6	1.6	8.60	4.50	2.5	1.1
Peak Current <sup>2</sup>	I <sub>P</sub>	amperes	11	9	6.5	3.5	17.5	10	7	2.6
Voltage Constant ±10%	K <sub>E</sub>	V/KRPM V/rad/sec	3.4 0.033	4.2 0.040	6.7 0.064	11.3 0.107	3.0 0.029	5.5 0.052	9.6 0.092	22.9 0.218
Torque Constant ±10%	K <sub>t</sub>	oz-in/amp N-m/amp	4.6 0.033	5.7 0.040	9.1 0.064	15.2 0.107	4.1 0.029	7.5 0.052	13.0 0.092	30.9 0.218
Resistance ±10%	R <sub>m</sub>	Ohms	.0875	1.45	3.55	9.2	0.35	1.3	4	21
Inductance ±10%	L <sub>m</sub>	mH	1.1	1.8	4.6	11.25	0.45	1.8	4.5	25

Parameter	Symbol	Units	DA23GBB				DA23JBB			
			-M100	-M200	-M300	-M400	-M100	-M200	-M300	-M400
Design Voltage	V	Volts DC	12	24	48	160	24	48	90	160
Cont. Stall Current <sup>1</sup>	I <sub>C</sub>	amperes	8.7	5.7	4.2	1.5	8.3	4.7	3.1	1.9
Peak Current <sup>2</sup>	I <sub>P</sub>	amperes	15.9	18.5	11.11	4.155	25.3	14.4	8.5	5.4
Voltage Constant ±10%	K <sub>E</sub>	V/KRPM V/rad/sec	4.9 0.047	6.5 0.062	10.0 0.095	26.7 0.255	6.7 0.064	11.2 0.107	18 0.172	28.1 0.268
Torque Constant ±10%	K <sub>t</sub>	oz-in/amp N-m/amp	6.6 0.047	8.8 0.062	13.5 0.095	36.1 0.255	9.0 0.064	15.1 0.107	24.3 0.172	38.0 0.268
Resistance ±10%	R <sub>m</sub>	Ohms	0.36	0.85	1.55	12.5	0.42	1.3	3	7.9
Inductance ±10%	L <sub>m</sub>	mH	0.6	1.3	2.35	18	0.7	2	4.3	14.5

**NOTES:** <sup>1</sup> Continuous rating based on 25°C ambient temperature, winding temperature rise of 100°C and motor mounted to a 6x6x¼ inch aluminum heat sink.

<sup>2</sup> 10 second at 25° C ambient, 100°C winding temp. <sup>3</sup> Inductance bridge method @ 1kHz.

Solutions in motion

**EAD**<sup>TM</sup> **motors**  
 Eastern Air Devices Inc.

# NEMA 23 Brushless DC Servo Motor

SIZE  
**23**

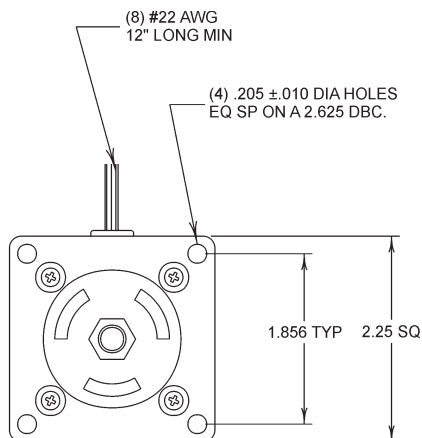
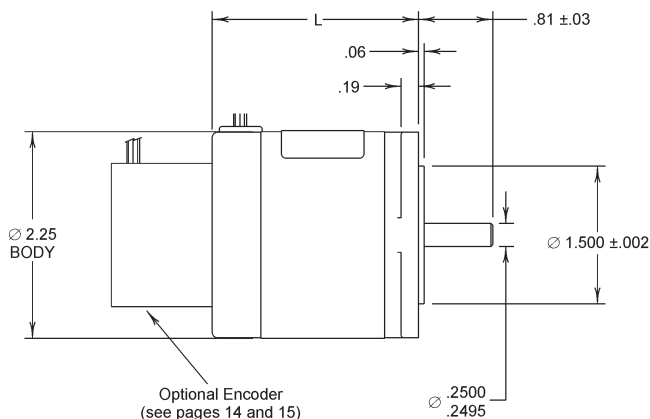

## Size 23

Model Series	Dimension "L"
DA23BBB	1.6 in (40.6 mm)
DA23DBB	2.0 in (50.8 mm)
DA23GBB	3.0 in (76.2 mm)
DA23JBB	4.0 in (101.6 mm)

See page 16 for Connection Diagrams.

## Pullout Torque Speed Curves

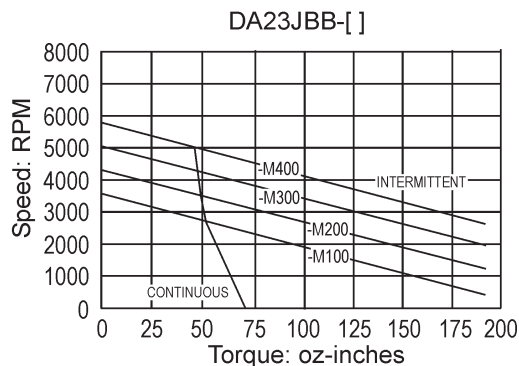
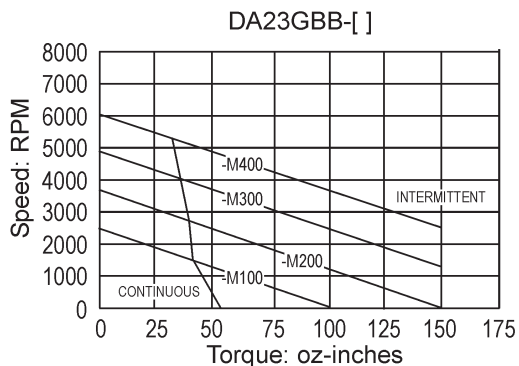
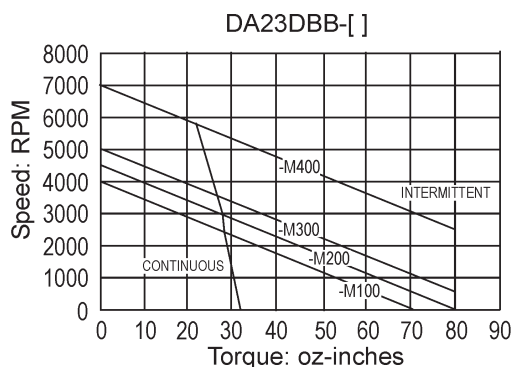
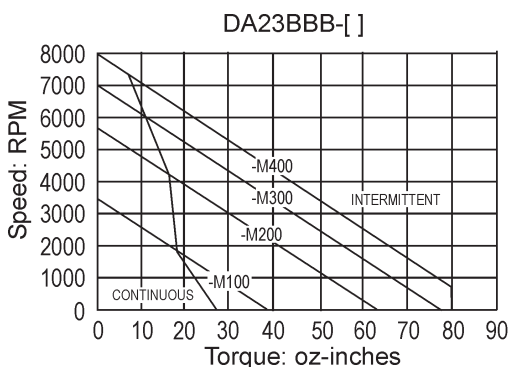

**SIZE**  
**34**

# NEMA 34 Brushless DC Servo Motor



## Features

- No brushes or commutator
- Ball bearing construction
- Dynamically balanced rotors
- Low audible and magnetic noise
- High-speed operation
- Compatible with all three-phase brushless DC motor amplifiers

## Typical Applications

- Centrifuges
- Bar code readers
- Film transport
- Machine tools
- Robotics
- Semiconductor equipment
- Gyroscopes
- Conveyors
- Paper feed
- X-Y positioning
- Light industrial

## Electrical Ratings

Parameter	Symbol	Units	DA34DBB	DA34FBB	DA34HBB
Cont. Stall Torque <sup>1</sup>	T <sub>C</sub>	oz-in N-m	77 0.55	134 0.95	147 1.04
Peak Torque <sup>2</sup>	T <sub>P</sub>	oz-in N-m	190 1.34	335 2.37	580 4.10
Motor Constant	K <sub>M</sub>	oz-in/ $\sqrt{\text{watt}}$ N-m/ $\sqrt{\text{watt}}$	12.6 0.09	18.9 0.13	19.7 0.14
Elec. Time Constant	$\tau_E$	msec	1.23	1.40	1.00
Mech. Time Constant	$\tau_M$	msec	6.75	4.47	6.00
Rotor Inertia	J	oz-in-sec <sup>2</sup> gm-cm <sup>2</sup>	0.00913 644.8	0.0139 981.6	0.0193 1363
Thermal Resistance	R <sub>TH</sub>	°C/watt	2.66	1.98	1.79
Weight	W	oz Kg	48 1.34	63 1.76	89 2.49
Motor Length	L	inch mm	3.2 80	3.7 94	4.7 119.4
# of Poles	—	—	4	4	4

## Winding Data

Parameter	Symbol	Units	DA34DBB				DA34FBB				DA34HBB			
			-10	-11	-12	-13	-10	-11	-12	-13	-10	-11	-12	-13
Design Voltage	V	volts	24	48	90	160	36	48	90	160	36	48	90	160
Cont. Stall Current <sup>1</sup>	I <sub>C</sub>	amperes	5.65	3.68	2.57	1.62	7.22	6.36	3.61	2.55	7.10	4.49	2.84	2.01
Peak Current <sup>2</sup>	I <sub>P</sub>	amperes	17.2	10.7	7.5	4.6	21.8	20	11.6	7.4	23.7	21.8	14.1	9.3
Voltage Constant ±10%	K <sub>E</sub>	V/kRPM V/rad/sec	8.4 0.080	13.5 0.129	19.5 0.186	31.4 0.300	11.7 0.112	12.9 0.123	22.2 0.212	35.1 0.335	18.4 0.176	20.2 0.193	31.3 0.299	47.8 0.456
Torque Constant ±10%	K <sub>T</sub>	oz-in/amp N-m/amp	11.36 0.080	18.26 0.129	26.37 0.186	42.46 0.300	15.82 0.112	17.44 0.123	30.02 0.212	47.47 0.335	24.88 0.176	27.32 0.193	42.33 0.299	64.64 0.456
Resistance ±10%	R <sub>M</sub>	Ohms	0.85	2	4.1	10.3	0.7	0.9	2.8	5.6	0.8	2	5	10
Inductance ±10%	L <sub>M</sub>	mH	0.9	2.6	5	13	1.0	1.3	3.2	8.2	1.6	2.1	4.6	10.3

**NOTES:** Motors are available with different windings and mechanical modifications to meet specific applications. Contact the factory for technical and engineering assistance.

<sup>1</sup> Continuous rating based on 25°C ambient temperature, winding temperature rise of 100°C and motor mounted to a 6x6x¼ inch aluminum heat sink.

<sup>2</sup> 10 second at 25° C ambient, 100°C winding temperature.

<sup>3</sup> Inductance bridge measurement method @ 1kHz.

Solutions in motion

**EAD**<sup>TM</sup> **motors**  
Eastern Air Devices Inc.



# NEMA 34 Brushless DC Servo Motor

SIZE  
**34**

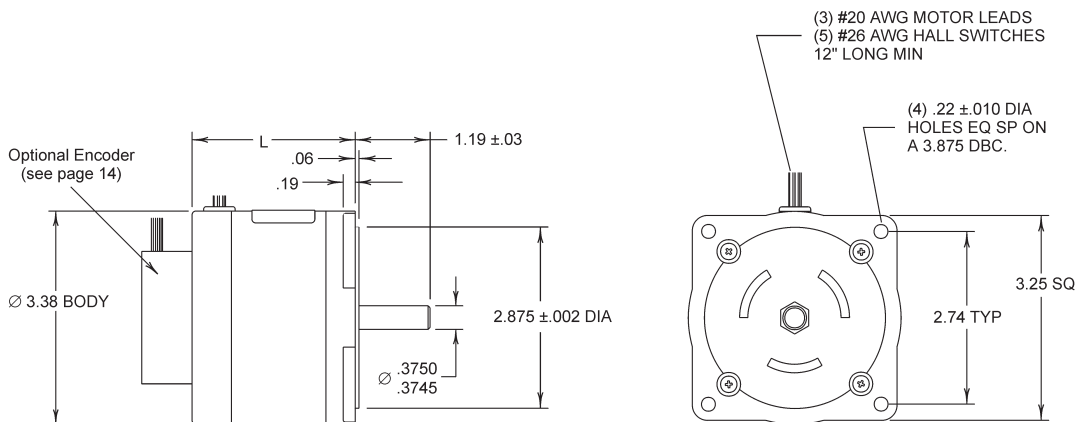

**Size 34**

Model Series	Dimension "L"
DA34DBB	3.1 in (80.0 mm)
DA34FBB	3.7 in (94.0 mm)
DA34HBB	4.7 in (119.4 mm)

See page 16 for Connection Diagrams.

## Pullout Torque Speed Curves

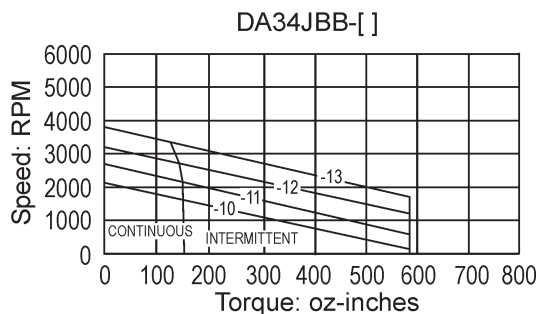
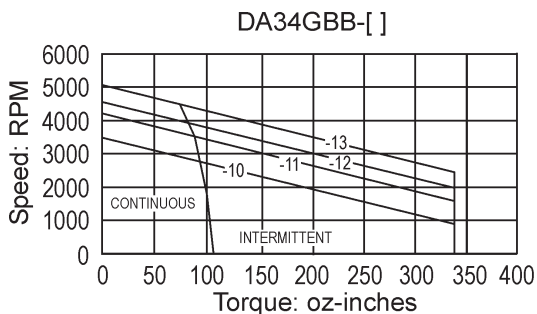
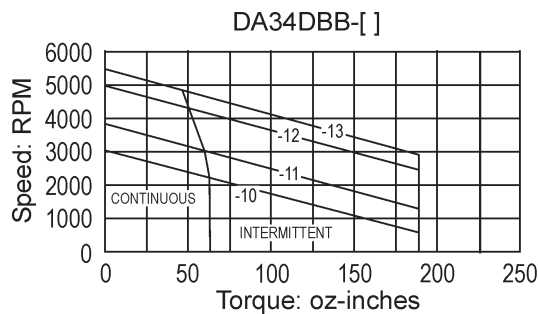

**SIZE**  
**42**

# NEMA 42 Brushless DC Servo Motor



## Features

- No brushes or commutator
- Ball bearing construction
- Dynamically balanced rotors
- Low audible and magnetic noise
- High-speed operation
- Compatible with all three-phase brushless DC motor amplifiers

## Typical Applications

- Centrifuges
- Bar code readers
- Film transport
- Machine tools
- Robotics
- Semiconductor equipment
- Gyroscopes
- Conveyors
- Paper feed
- X-Y positioning
- Light industrial

## Electrical Ratings

Parameter	Symbol	Units	DA42DBB	DA42FBB	DA42HBB
Cont. Stall Torque <sup>1</sup>	T <sub>C</sub>	oz-in N-m	123 0.87	180 1.27	265 1.87
Peak Torque <sup>2</sup>	T <sub>P</sub>	oz-in N-m	395 2.79	610 4.31	840 5.93
Motor Constant	K <sub>M</sub>	oz-in/√watt N-m/√watt	14.3 0.100	20.0 0.140	28.0 0.196
Elec. Time Constant	τ <sub>E</sub>	msec	1.07	1.39	1.70
Mech. Time Constant	τ <sub>M</sub>	msec	2.08	1.59	1.35
Rotor Inertia	J	oz-in-sec <sup>2</sup> gm-cm <sup>2</sup>	0.00357 252.1	.00536 378.5	.00893 630.6
Thermal Resistance	R <sub>TH</sub>	°C/watt	1.33	1.20	.95
Weight	W	oz Kg	230 6.44	255 7.14	300 8.40
Motor Length	L	inch mm	5.7 144.8	6.2 157.5	7.2 182.9
# of Poles	—	—	4	4	4

## Winding Data

Parameter	Symbol	Units	DA42DBB				DA42FBB				DA42HBB			
			-10	-11	-12	-13	-10	-11	-12	-13	-10	-11	-12	-13
Design Voltage	V	volts	36	48	90	160	36	48	90	160	36	48	90	160
Cont. Stall Current <sup>1</sup>	I <sub>C</sub>	amperes	7.5	6.1	3.8	2.2	8.9	7.6	4.4	2.6	12.3	9.9	5.7	3.4
Peak Current <sup>2</sup>	I <sub>P</sub>	amperes	24.7	20.6	13.0	7.7	32.2	27.1	15.8	9.8	38.7	31.3	19.1	12.1
Voltage Constant ±10%	K <sub>E</sub>	V/kRPM V/rad/sec	12.0 0.114	14.4 0.138	22.9 0.218	38.5 0.368	14.1 0.135	16.9 0.161	28.8 0.275	46.8 0.447	16.3 0.155	20.1 0.192	33.1 0.316	52.6 0.502
Torque Constant ±10%	K <sub>T</sub>	oz-in/amp N-m/amp	16.2 0.114	19.5 0.138	30.9 0.218	52.1 0.368	19.1 0.135	22.8 0.161	38.9 0.275	63.3 0.447	22.0 0.155	27.2 0.192	44.8 0.316	71.1 0.502
Resistance ±10%	R <sub>M</sub>	Ohms	1.3	1.9	4.7	13.2	0.9	1.3	3.8	9.9	0.6	0.9	2.6	6.4
Inductance ±30%	L <sub>M</sub>	mH	1.4	2.0	5.0	14.1	1.3	1.8	5.3	13.9	1.0	1.5	4.2	12.3

**NOTES:** Motors are available with different windings and mechanical modifications to meet specific applications. Contact the factory for technical and engineering assistance.

<sup>1</sup> Continuous rating based on 25°C ambient temperature, winding temperature rise of 100°C and motor mounted to a 6x6x¼ inch aluminum heat sink.

<sup>2</sup> 10 second at 25° C ambient, 100°C winding temperature.

<sup>3</sup> Inductance bridge measurement method @ 1kHz.

Solutions in motion

**EAD**<sup>TM</sup> **motors**  
Eastern Air Devices Inc.

# NEMA 42 Brushless DC Servo Motor

SIZE  
42

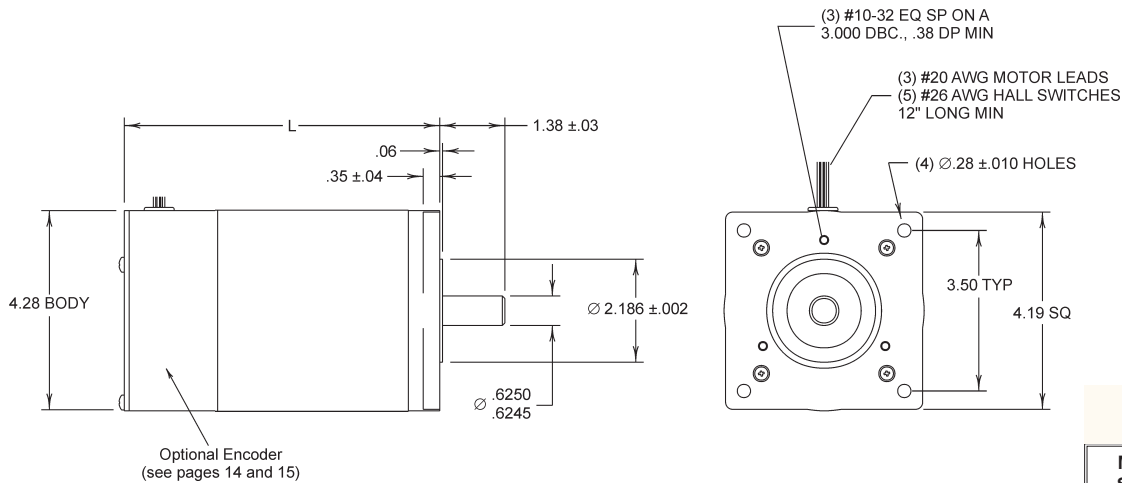

Size 42	
Model Series	Dimension "L"
DA42DBB	5.7 in (144.8 mm)
DA42FBB	6.2 in (157.5 mm)
DA42HBB	7.2 in (182.9 mm)

See page 16 for Connection Diagrams.

## Pullout Torque Speed Curves

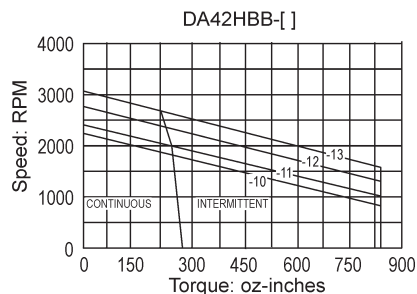
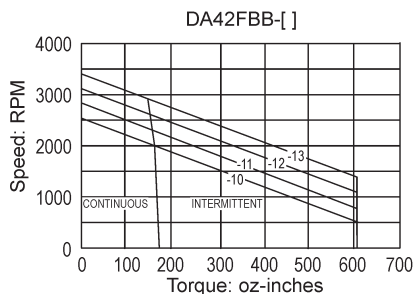
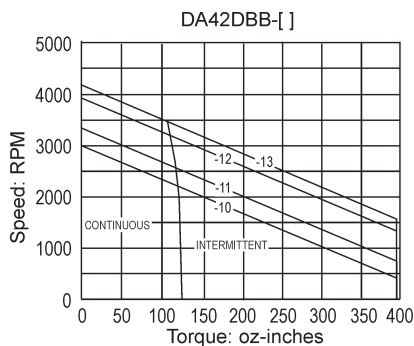

SIZE  
**39**

# Size 39 Open Frame Brushless DC Motor



## Features

- No brushes or commutator
- Ball bearing construction
- Dynamically balanced rotors
- Low audible and magnetic noise
- High-speed operation
- Compatible with all three-phase brushless DC motor amplifiers

## Typical Applications

- Centrifuges
- Bar code readers
- Film transport
- Machine tools
- Robotics
- Semiconductor equipment
- Gyroscopes
- Conveyors
- Paper feed
- X-Y positioning
- Light industrial

## Electrical Ratings and Winding Data

Parameter	Symbol	Units	DB39DFB-10	DB39DFB-11	DB39DFB-12	DB39DFB-13	DB39DFB-14
Rated Torque		oz-in	60	60	58	55	54
Peak Torque	$T_P$	oz-in	150	150	150	150	150
Motor Constant	$K_M$	oz-in/ $\sqrt{\text{watt}}$	8.2	8.2	8.2	8.2	8.2
Design Voltage	V	VDC	36	48	90	130	160
Max Speed		RPM	3200	3800	5500	6700	7200
Rated Speed		RPM	2030	2600	4370	5650	6100
Rated Current		amperes	4.1	3.7	2.75	2.2	1.9
Voltage Constant	$K_E$	V/kRPM	11.2	12.6	16.3	19.1	22.3
Torque Constant	$K_T$	oz-in/amp	15.1	17.1	22.0	25.8	30.2

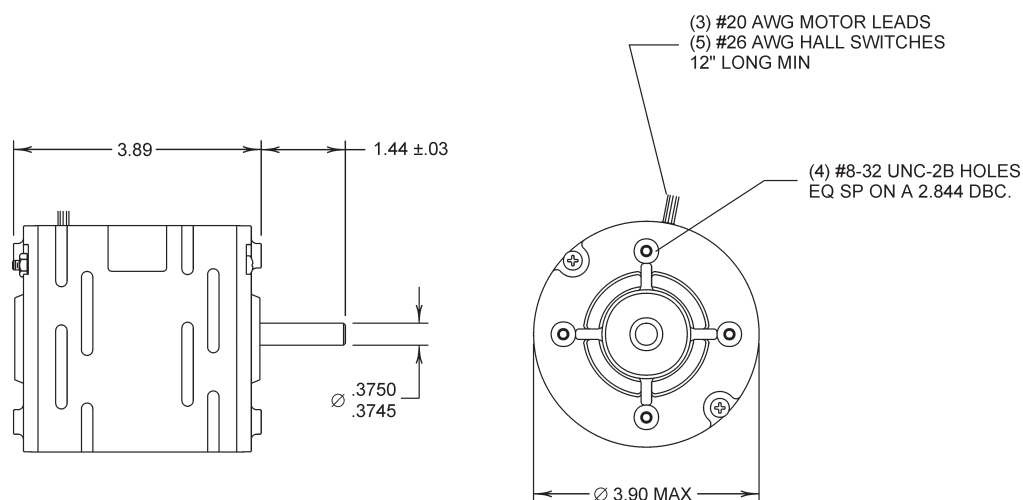

## Pullout Torque Speed Curves

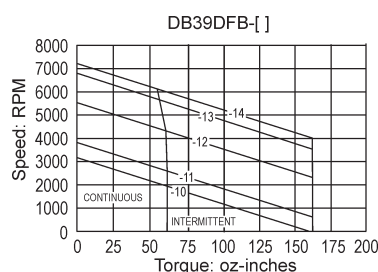

# Miniature Brushless DC Motors

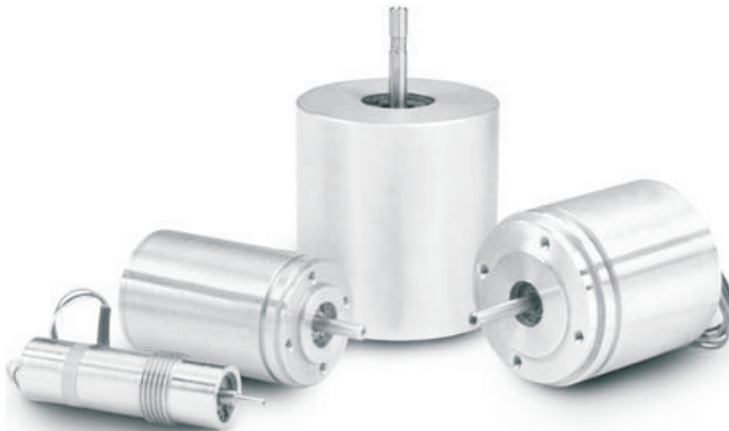

EADmotors offers a line of small, custom designed brushless DC motors for demanding applications. EADmotors has built a reputation for supplying the highest quality miniature brushless DC motors available. These motors are custom designed on an application specific basis to meet the most demanding application requirements.

Lightweight aluminum housings and high energy rare earth magnets make these motors ideal for aircraft applications. Modified designs with stainless steel housings are ideal for medical, laboratory, and surgical applications.

## Custom Designs

Custom designs are available in the following frame sizes:

### Frame Sizes

Frame Size	Diameter
Size 5	.5 in
Size 10	1.0 in
Size 15	1.5 in
Size 18	1.8 in

Contact EADmotors Engineering for application assistance.

EADmotors miniature brushless DC motors are available for precision applications. Features include the following:

- Precision engineered for demanding applications
- High-speed ball bearing construction up to 20,000 RPM
- High-temperature, Class F insulation
- Stainless steel shafts and housings for medical applications
- Lightweight aluminum housings for aircraft applications
- Customized mechanical designs
- High energy rare earth magnets for maximum power density



# High Performance Encoder

## Specifications

- **Resolution:**  
250 to 8192 pulse/resolution
- **Accuracy:**  
Incremental  $\pm 3$  arc-min  
Maximum
- **Phasing:**  
Incremental  $90^\circ \pm 18^\circ$   
Electrical
- **Symmetry:**  
Incremental  $180^\circ \pm 18^\circ$   
Electrical
- **Power Requirements:**  
5 VDC  $\pm 10\%$  at  
200 mA Maximum
- **Output Signal:**  
Line Driver  
AM26C31IDB  
sink/source 20 mA max
- **Frequency Response:**  
500 kHz Maximum
- **Temperature:**  
Operating Temp:  
 $-30^\circ\text{C}$  to  $+115^\circ\text{C}$   
Storage Temp:  
 $-40^\circ\text{C}$  to  $+125^\circ\text{C}$
- **Shock/Vibration:**  
Shock: 50 G's for 11 ms  
duration  
Vibration:  
5-2000 Hz @ 10 G's
- **Humidity:**  
90% relative  
(non-condensing)
- **Sealing:**  
IP Rating: IP 40

## Models E20, E21, E22 (to replace Models E2, E3, E4, E5)

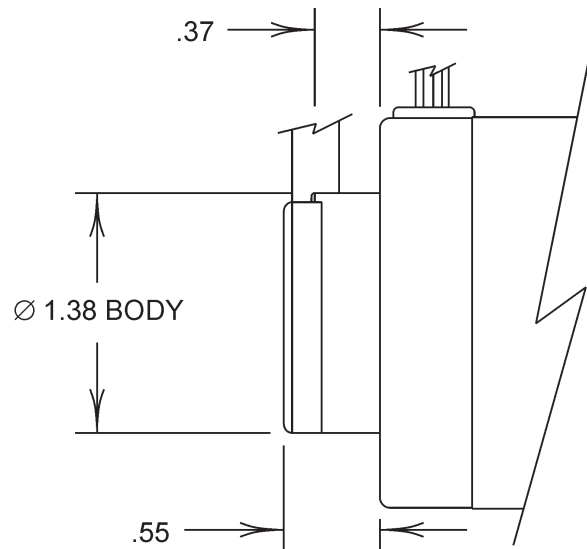

## Connector Layout



## Connections

Function	Lead Color	Pin
A	YEL	1
A <sup>1</sup>	YEL/WHT	2
B	BLU	3
B <sup>1</sup>	BLU/WHT	4
Z	ORG	5
Z <sup>1</sup>	ORG/WHT	6
S1	GRN	7
S1 <sup>1</sup>	GRN/WHT	8
S3	BRN	9
S3 <sup>1</sup>	BRN/WHT	10
S2	VIO	11
S2 <sup>1</sup>	VIO/WHT	12
VCC	RED	13
GROUND	BLK	14
FGND	BLK/WHT	15

## Output Configuration:

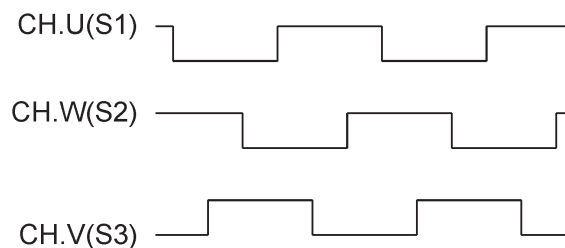
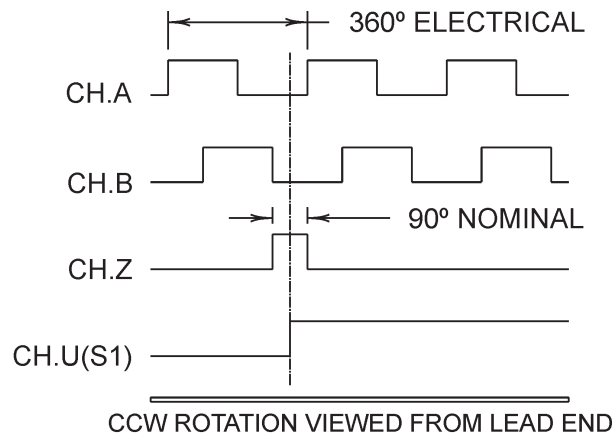

## Encoder P/Ns

Encoder #	Line Count	Stocked
E20	500	NO
E21	1000	YES
E22	2000	NO

## NOTES:

1. Motors with these encoders do not have hall effect sensors.
2. Encoders supplied with a 18-inch shielded cable.
3. Warning: Do not remove encoder cover as sensitive electronics can be damaged.
4. Other options are available. Please consult factory for special requests.

# Low Profile Encoder

## Models E6, E7, and E8

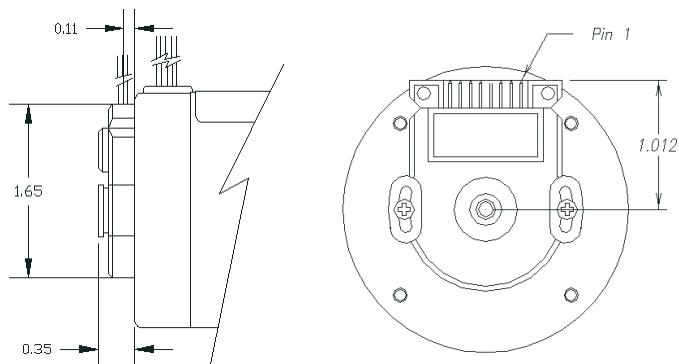

### Connections

Function	Pin #
Ground	1
Z	2
Ch. A	3
+5VDC	4
Ch. B	5
Ch. S2	6
Ch. S1	7
Ch. S3	8

### Output Configuration

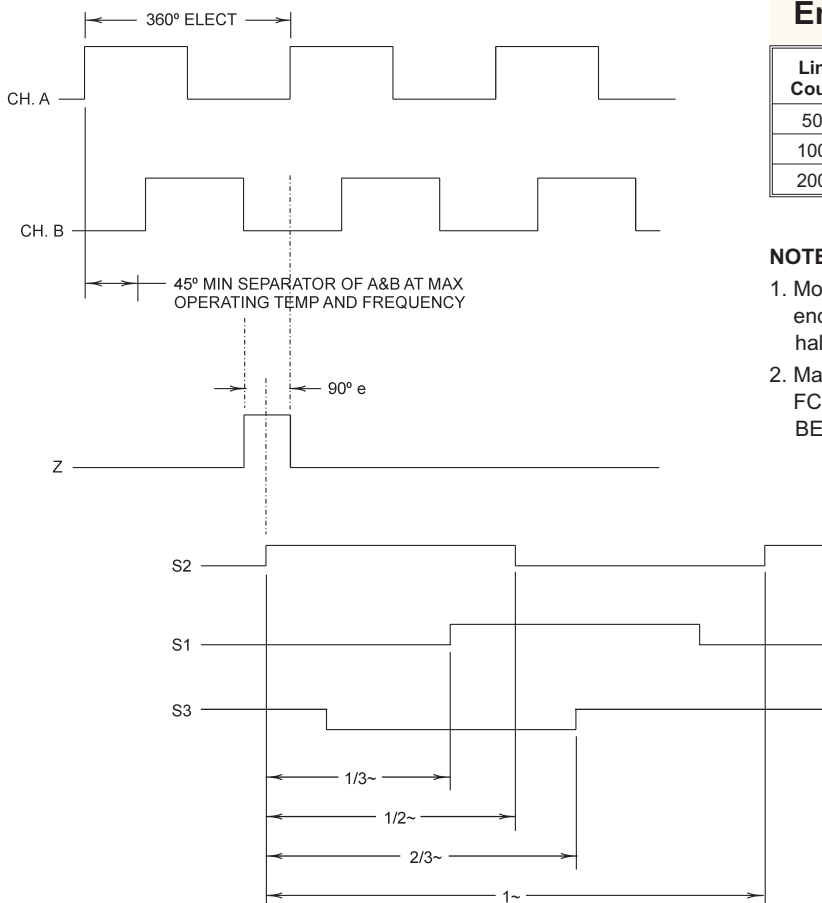

### Encoder P/Ns

Line Count	P/N	Stocked
500	E6	No
1000	E7	Yes
2000	E8	No

### NOTES:

1. Motors with these encoders do not have hall sensors.
2. Mating connector FCI Electronics BERG 90312-008.

CCW viewing encoder top.

### Specifications

- **Resolution:**  
500, 1000, 2000
- **Phasing:**  
Incremental  $\pm 36^\circ$  electrical.
- **Symmetry:**  
Incremental  $\pm 36^\circ$  electrical.
- **Power Requirements:**  
5 VDC  $\pm 10\%$  at 70 mA.
- **Output Signal:**  
Voltage Comparator with open collector output sinks 4 mA.
- **Frequency Response:**  
300 kHz maximum.
- **Environmental:**  
Operating temperature:  $-30^\circ\text{C}$  to  $+100^\circ\text{C}$ .  
Storage temperature:  $-40^\circ\text{C}$  to  $+115^\circ\text{C}$ .  
Shock: 50 G's for 11ms duration.  
Vibration:  
5-2000 Hz @ 10 G's.  
IP Rating: IP 40.  
Humidity: 90% relative (non-condensing).

# Connection Diagram

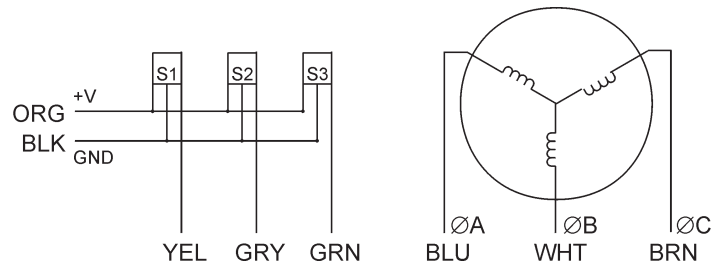

## Connection Diagram

Commutation Table					
Sensor Output			Driver Output		
S1	S2	S3	Ø A	Ø B	Ø C
YEL	GRY	GRN	BLU	WHT	BRN
CCW Rotation Facing Lead End					
0	0	1	X	HI	LO
0	1	1	HI	X	LO
0	1	0	HI	LO	X
1	1	0	X	LO	HI
1	0	0	LO	X	HI
1	0	1	LO	HI	X
CW Rotation Lead End					
0	1	0	LO	HI	X
0	1	1	LO	X	HI
0	0	1	X	LO	HI
1	0	1	HI	LO	X
1	0	0	HI	X	LO
1	1	0	X	HI	LO