



Technical Data Sheet

Linear Piezomotor LBS004 Series

The LBS linear piezo motor represents a quantum leap in the design of small size high-performance DC motors. Manufactured from light weight reinforced engineering thermoplastics with a precision linear slide, this motor provides superior precision and ultrafast response/start-stop characteristics with an affordable design. Highly energy efficient, the motor consumes zero power in hold position while still providing significant force. Available in a variety of configurations (including non-magnetic) it is the ideal choice for OEM applications where superior performance and competitive unit cost are important factors.

Motor Specifications	Standard	Encoder
Mode of Operation	Stepping & Continuous	
Push/Pull Force	>4N	>4N
Self Braking Force	>4N	>4N
Response Time	20µs to 30µs	
Velocity Range	0 to 0.2 m/s	0.014 to 140mm/s
Travel Range	10 mm	
Minimum Linear Step (resolution)	<0.05 µm	<0.05 µm
Minimum controlled Linear Step	N/A	2.6 µm
Dynamic Range	4 kHz	
Bi-Directional Repeatability	N/A	±2.6 µm
Angular Hysteresis at Direction Change	< 1.5 arc.min	< 1.5 arc.min
Supply Voltage for Driver	12 VDC	
Operating Temperature	-20° to 80°C	
Maximum Current over velocity range	350mA	
Motor Weight	22g	25g
Motor Dimensions (mm)	40x31x11	40x34x11
Driver PCB Dimensions (mm)	48x63x25	48x63x25
Control	Open loop	Closed loop

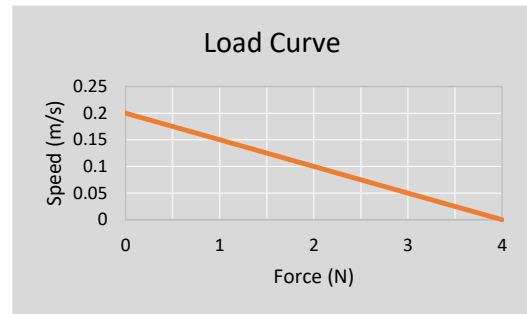
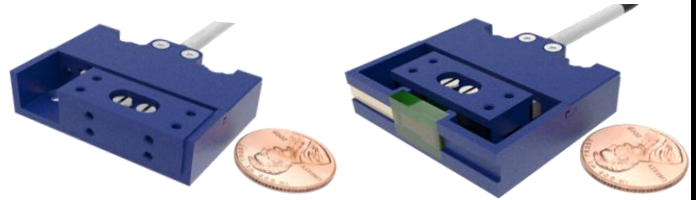

Note 1

Note 1: Maximum current in continuous mode. Use of PWM with different duty will proportionally reduce average current.

Principle of Operation

DTI's linear piezomotors work on a patented principle of excitation of ultrasonic standing waves within a piezoelectric resonator. The resulting superposition of two orthogonal ultrasonic waves causes linear movement of the motor (for more details visit www.dtimotors.com). DTI's electronic driver's have been designed to provide an economical user-control interface. Each driver PCB is supplied pre-programmed for the specific motor model and is software configurable to provide optimization of drive signals and integrated controls. Closed loop control of the motor is achieved via an optical encoder mounted on the back of the motor. Refer to the Electronic Driver 'ED' technical data sheet for full details of Electronic Drivers.

Performance and Key benefits vs. Electromagnetic Motors

Improved Resolution:	With a control step size of just 0.05 µm at full thrust or holding force these linear motors offer 20,000 steps per mm of control
Faster reaction time:	Within 20µs to 30µs the Piezomotor has made its first step and motion has commenced compared to a stepper motor with typical 5ms to start motion.
High Force Density	For its size and weight these motors offer superior force density, particularly when compared with stepper and lead screw solutions
Energy and Cost Saving	The Piezomotor consumes zero power at holding force and very low power at slow speed (0.06 W at 1 mm/s) yielding the possibility of very efficient overall duty.
Special Properties	Is immune to EM and RF interference and emits no interference.
Economical Design	The innovative design and Patent protected technology packaged in stable reinforced engineering thermoplastic makes this high performance technology affordable for OEM equipment designers
Lightweight	The Piezomotor contains no copper windings, iron laminations or permanent magnets and is significantly more powerful by weight than EM solutions. This makes them ideally suited to weight critical applications.

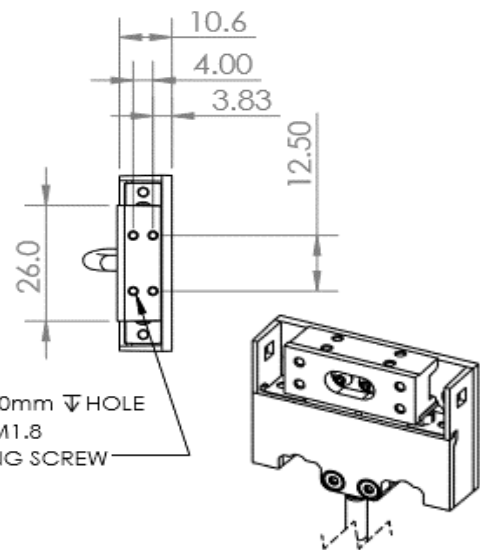
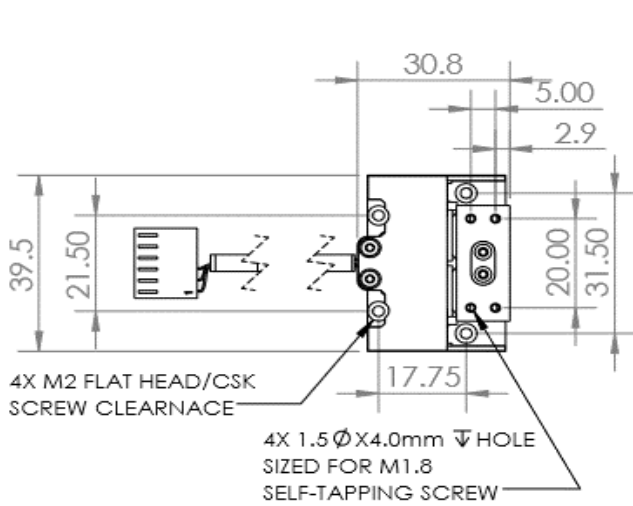

Encoder Model

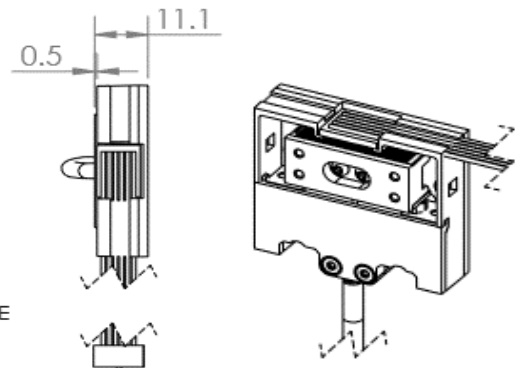
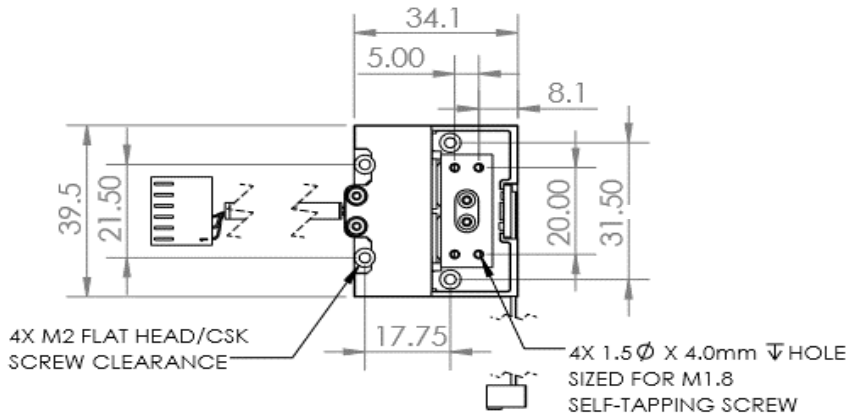

Motor Control

Motor

Control of DTI Piezomotors is straightforward. Each motor requires a driver board which will convert motion input instructions to the necessary electrical processes with specific frequency and amplitude to create excitation of the Piezo resonator and make the motor perform the motion path instructed.

Control Options

Where fitted, motors can be manually controlled to move in either direction with two pushbuttons on the Driver PCB. Two external input control pins can be used to provide control signals to the Driver board to move the motor in either direction. PWM can be used to control speed and step size.

A single square pulse of 30µs will achieve the minimum controlled step. With a train of square pulses the length of pulse will determine the size of the step made and the time between pulses will determine motor speed. The motor will run continuously at full speed if the control signal is applied continuously.

A control programme in a third party controller or on an OEM control board must be written to apply motor control signals and to close the feedback loop using the signal from the encoder.

The minimum controllable step is limited by the encoder resolution.

Sold & Serviced By:



Toll Free Phone (877) SERV098
www.electromate.com
sales@electromate.com

Control Architecture

	Base Motor	Motor with Encoder
Open loop Driver	Open Loop Control or 3rd Party controller command motor with PWM control and close control loop with external sensor.	3rd Party controller command motor with PWM control and close control loop DTI Encoder output

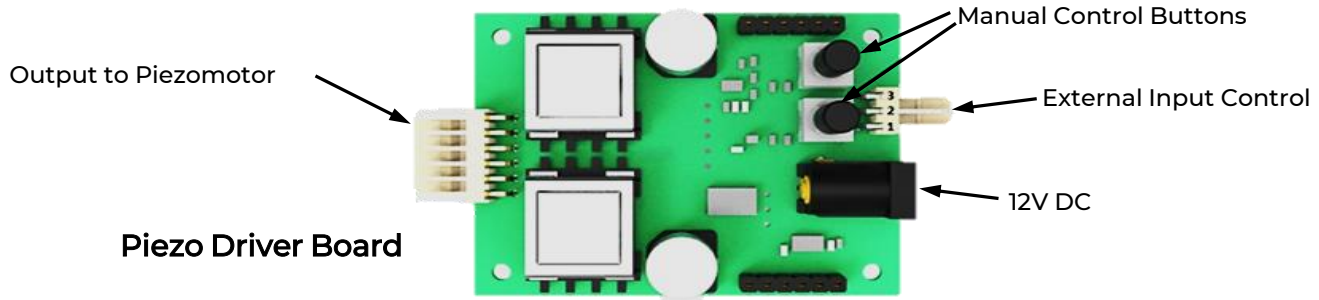

Ordering Information

Motor

Part Number

LBS004010LAC30	Linear Piezomotor 10 mm travel, 4N Force, 30 cm cable with connector
LBS004010LAC30-E	Linear Piezomotor with Encoder, 10 mm travel, 4N Force, 30 cm cable with connector
LBS004010LAC30-K	Evaluation Kit (4N linear piezomotor 10 mm travel, electronic driver, cables, 12 VDC PSU, instruction manual)
LBS004010LAC30-EK	Encoder Evaluation Kit (4N linear piezomotor+Encoder, 10 mm travel, electronic driver , cables, 12 VDC PSU, instruction manual)
LBS004010LAW15	Linear Piezomotor 10 mm travel, 4N Force, 15 cm cable no connector
LBS004010LAW15-E	Linear Piezomotor with Encoder, 10 mm travel, 4N Force, 15 cm wires, no connector

Electronic Driver

EDB60V010BB	Electronic Driver pcb - Open Loop board only
EDB60V010BE	Electronic Driver pcb - Open Loop, with enclosure

Refer to Electronic Driver 'ED' Data Sheet for further information on Piezomotor control techniques and driver electronics

Sold & Serviced By:

 **ELECTROMATE**

Toll Free Phone (877) SERV098
www.electromate.com
sales@electromate.com