

# CIMON XPANEL

HUMAN MACHINE INTERFACE



# DURABLE HIGH SPEED INTUITIVE

CIMON Xpanel takes your HMI experience to the next level. Our products offer proven reliability for any industrial environment and our intuitive design software enables rapid project development.





# PRODUCT PERFORMANCE

## XPANEL HMI

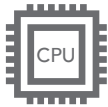

### High-Speed CPU Processor

Equipped with high-speed industrial CPU



### Aluminum Die-Casted Front Bezel

Improved heat and shock resistance protects the electrical components in the unit (iXT10 and larger models)



### Extensive Lineup

Available in a wide range of display size, from 4.3" to 15"

### Variety of Interfaces

Includes Ethernet, Serial (RS-232C/485), USB, and SD card options



Sold & Serviced By:

Canadian and International Sales  
**ELECTROMATE**  
877-737-8698  
sales@electromate.com  
www.electromate.com

U.S. Sales  
**SERVO2GO.com**  
877-378-0240  
sales@servo2go.com  
www.servo2go.com



### Ultrafast CPU Processor

Equipped with a high-speed industrial grade CPU to handle complex scripts and graphics processing with ease, which adds stability to the system.

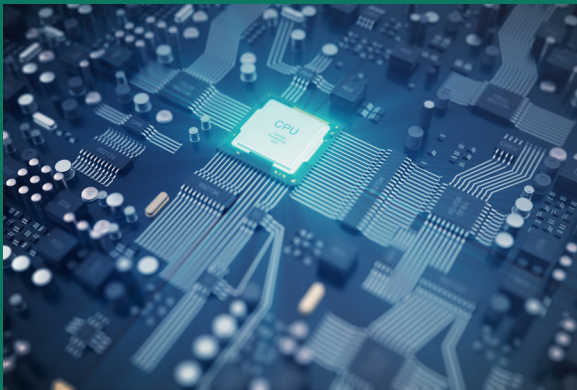

### Operating Temperature of -10–60°C

Reliable operation, even in extreme conditions, allows users to monitor and control their facilities in harsh environments.



### High-Definition Display

A maximum of 16.7M color XGA display allows the expression of intricate details. The industrial grade LCD panel generates low power and heat, which extends the display's lifetime up to 100,000 hours while ensuring full brightness and vividness.

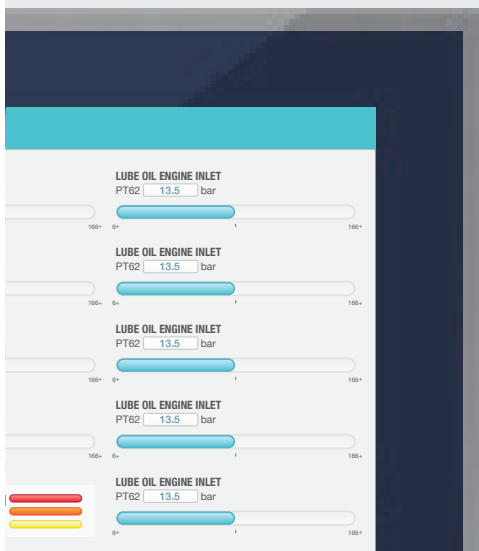

### Extreme Durability

All models are IP65 certified, NEMA 4X rated, and the touch screen is fortified to add scratch resistance.



# PRODUCT PERFORMANCE

## XPANEL RUNTIME SOFTWARE



### Recipe

A recipe is a collection of data that can be easily changed with the user's pre-defined values. For example, in a cookie production factory that produces different types of cookies, the operator can manipulate the ingredient data values between different flavor profiles. The recipe settings can be simply created, modified, or deleted during production. Also, recipe data can be imported and exported during runtime.



### Data Logging

Raw or internal data can be recorded when certain criteria is met. The data is internally collected in the memory, which the operator can convert into CSV format. A USB drive or SD card can also be connected to the Xpanel, allowing the user to save as much data as the storage unit allows.



### Script

Engineers can easily build a program using a script similar to C language. Scripts allow the operation of various actions, such as opening a page or changing device settings. Scripts can be triggered and executed in different ways: automatically, manually, periodically, or upon opening/closing a page.



### Schedule Tasks

Schedule allows users to plan programs to be run at specific times. Scheduled events can be set to execute daily, weekly, monthly, or yearly, allowing for easier management of the facility.



## Alarm

Alarms are used to monitor data values and inform users about specific operating conditions. Alarm information and history can be checked on the display. A large number of alarms can be created and categorized into a maximum of 10 groups. Depending on the alarm group, specific scripts can run to take appropriate actions when an alarm triggers. The alarm history can also be exported as a CSV file and read with MS Excel. Alarm messages can appear at the bottom of the currently active screen, while allowing the operator to continue with normal functionality.



## Distribution Management

Supports RFID reader to manage the logistics of the distribution system more efficiently (compatible with Omron, Sick, and LS products). Affinity with barcode readers via serial or USB type, with the capability for the operator to display the barcode on the screen ('Code 39' function).



## Multilingual Feature

Xpanel supports virtually any language to be displayed on the screen. All fonts provided by Windows can be used.

**\*Note:** CIMON is not liable for the download and/or use of illegally downloaded fonts that may be subject to legal action.



## Data Bridge

Xpanel can act as a bridge that allows for the synchronization of data between other devices. Even devices that are connected to different serial ports, or serial and Ethernet ports can exchange data.



## Remote Diagnostic Service

Our technicians can connect to your Xpanel through Ethernet and provide support. This allows for quick resolution due to the status of the Xpanel unit being analyzed without a site visit.



## Security

To give our customers protection for both their system and employees, Xpanel comes with built-in security settings that prevent unauthorized access or unskilled manipulation. An administrator has the ability to assign different functions to operators with up to 10 security levels.



## Screen Capture

Screenshots of the current screen can be taken during runtime. The image is saved as a bitmap file and can be used when creating a report for management.



## VNC

Xpanel provides a solution for monitoring and controlling the system from anywhere with an Ethernet connection. The system can be supervise via PC or smartphone.



## Simulator

The operator can virtually reproduce the project by using the 'Simulator'. This feature can be used when there are no physical devices available and there is a need to test a project. The simulator includes a remote control feature which can change the PLC address for a more realistic simulation.



## Fully Tested and Certified

All Xpanel models are NEMA 4X rated, and are thoroughly tested and certified to meet all international compliance standards for the FCC, CE, ICC, and UL. The absolute highest standards of health, compliance, and safety are achieved for the consumer and workplace even in the most extreme environments.

# PRODUCT PERFORMANCE

## NETWORK CONFIGURATION

CIMON Xpanel easily connects to other devices through a plethora of communication drivers we offer, making it possible to provide powerful flexibility for building your control system.

### SERIAL NETWORK

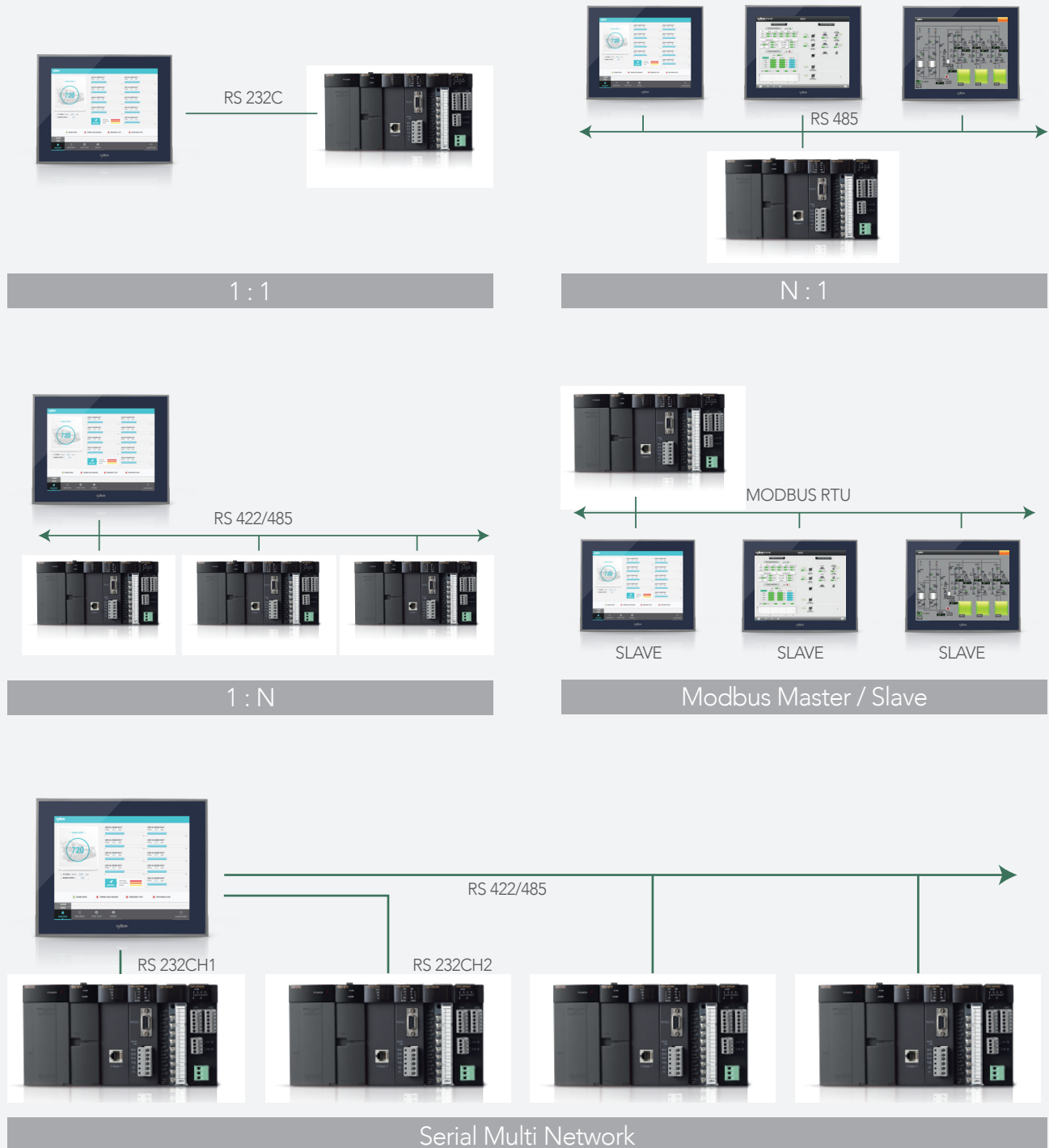



# X-PANEL

## CIMON NETWORK

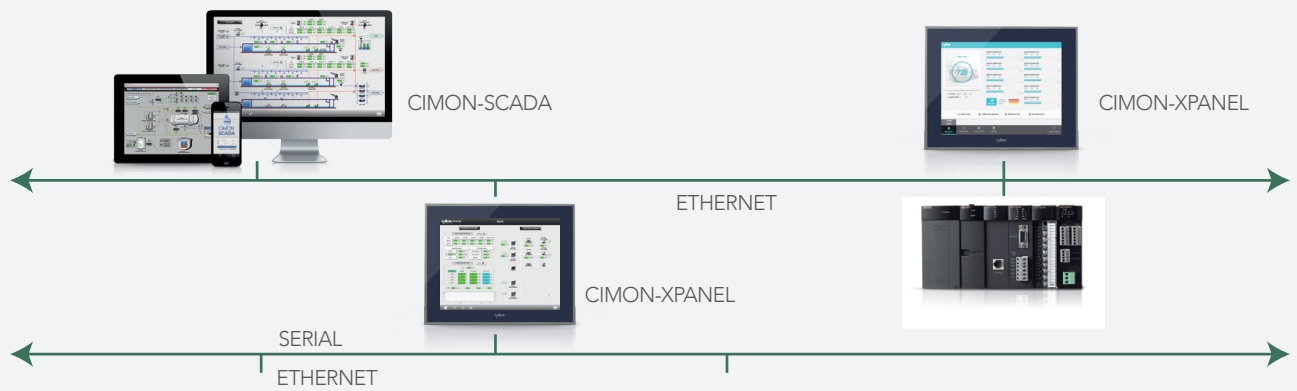

## ETHERNET NETWORK

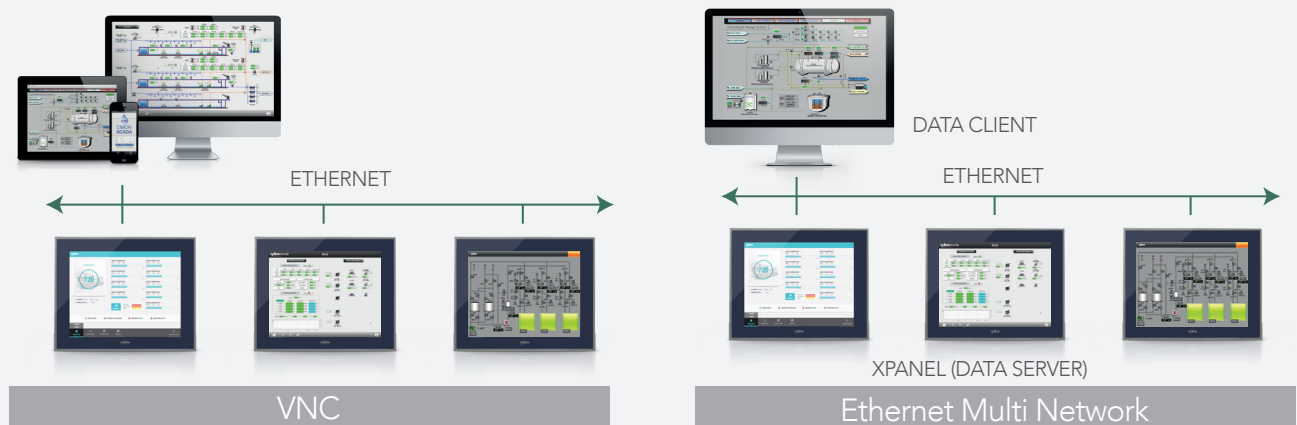
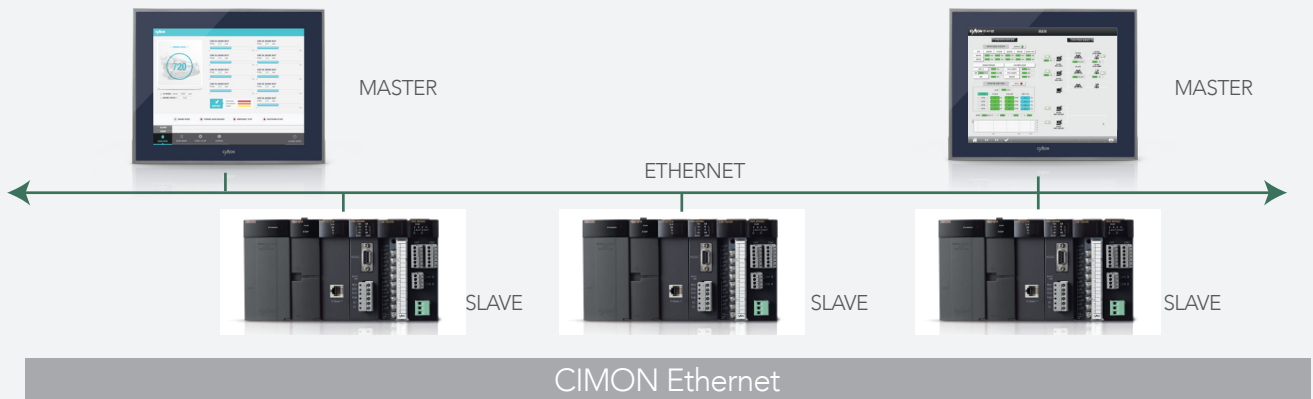

# PRODUCT PERFORMANCE

## SOFTWARE

XpanelDesigner can make your facility smarter and more powerful.

### User-Friendly Development Software

XpanelDesigner

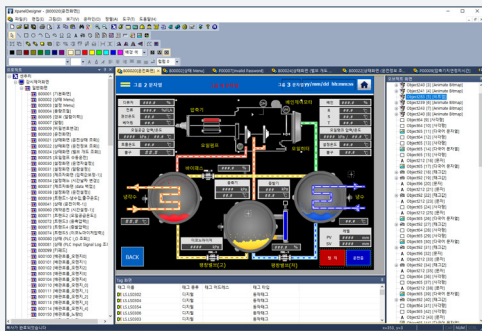

- Drag-and-Drop function  
Just drag and drop images. It's that easy!

### Smart HMI and Software

Design your system with library images.

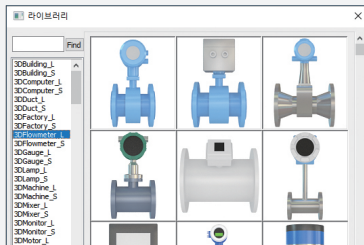

- ▷ XpanelDesigner provides various graphical objects to allow rapid project development.

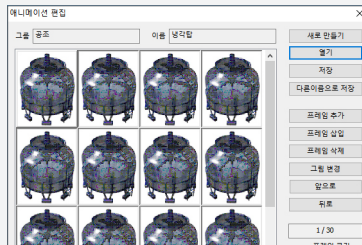

- ▷ Create your own animated objects.

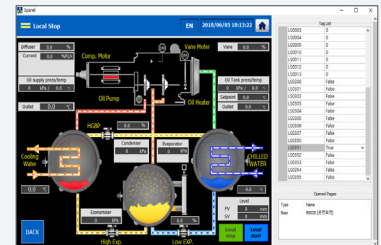

- ▷ Preview the project on a PC with the simulator.

### Convenient and Reliable HMI

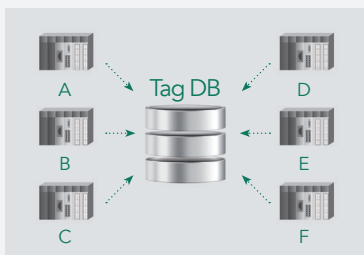

- ▷ All the PLC address data can be identified and modified in the database.



- ▷ Create pages from numerous language choices.



- ▷ Front aluminum die-casted bezel increases the durability of Xpanel.

# CIMON-XPANEL SPECIFICATION

## PRODUCT SPECIFICATION

Xpanel comes in sizes that are suitable for small to large scale facilities. Also, proven reliability and performance ensure that maximum value is provided in every industrial environment.



Item	Specifications
General Voltage	DC 24 V or AC 100-240 V
Operating Temperature	-10–60°C
Non-operating Temperature	-25–70°C
Operating Humidity	10–85% RH (below 29° C, no condensation)
Non-operating Humidity	10–85% RH (below 39° C, no condensation)
Environmental Condition	800–1114 hPa (below 2000 m)
Dust	≥ 0.1 mg/m <sup>3</sup>
Pollution Degree	Pollution degree 2
Air Condition	Avoid corrosive gas and excessive dust
Vibration Resistance	SSD storage type 9.8 m/s <sup>2</sup> , 10–25 Hz in X, Y, Z (80 min)
Noise Immunity (Impulse Noise)	Impulse, EFT/Burst, Surge, ±2 kV, 1 uS
Electrostatic Discharge Immunity	4 kV (IEC61000-4-2 level 3), 8 kV (Air discharge)

# CIMON-XPANEL SPECIFICATIONS

## PRODUCT SPECIFICATIONS

Type	XT04CD-DE	XT07CD-DE	iXT10CD-D	iXT12CD-A	iXT15CD-A
Panel Size	4.3"	7"	10.4"	12.1"	15"
Resolution	480 x 272	800 x 480	800 x 600		1024 x 768
LCD	Color TFT				
Color	65k colors		262k colors		16.7M colors
Luminance	400 cd/m <sup>2</sup>	400 cd/m <sup>2</sup>	700 cd/m <sup>2</sup>	800 cd/m <sup>2</sup>	350 cd/m <sup>2</sup>
LCD Lifetime	20,000 hrs		100,000 hrs		70,000 hrs
Memory	128 MB DDR2 SDRAM		512 MB DDR2 SDRAM		
Storage	128 MB SLC NAND Flash				
Operating System	Windows CE 6.0		Windows Embedded Compact 7		
Programming Tool (HMI)	XpanelDesigner				
Audio	None	1 Port	None		
Interface	Ethernet	10/100BASE-T			
	Serial (COM1)	RS-232C		RS-422/485	
	Serial (COM2)	RS-422/485		RS-232C	
	Serial (COM3)	None		RS-232C	
	USB Host	1 Port			
	Tool Port	1 Port			
	SD Card Slot	None	1 Slot		
Input Power	DC 24 V	DC 24 V	DC 24 V	AC 100-240 V	
Dimension (mm)	128 X 102 X 50	185 X 127 X 50	280 X 220 X 47	330 X 250 X 83	395 X 310 X 89
Panel Cut (mm)	120 X 94	177 X 119	267 X 207	319 X 239	382 X 297
Enclosure	Plastic		Aluminum		
Power Consumption	4 W	6 W	9 W	10 W	15 W
Item Weight	0.45 kg (0.99 lbs)	0.78 kg (1.72 lbs)	2.47 kg (5.45 lbs)	3.2 kg (7.06 lbs)	4.5 kg (9.92 lbs)

# CIMON XPANEL HYBRID

Two devices, HMI and PLC, are combined into one product for your convenience.



### VESA Wall Mount

Get a clean and safe installation for articulating arms using the VESA Mount.



### PLC-S Embedded

Xpanel Hybrid comes fully capable right out of the box with a built-in PLC-S CPU.



### Separated Terminal

Use both XpanelDesigner and CIMON PLC software to easily connect to other devices using the built-in USB mini-B port.

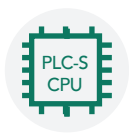

### PLC-S Expansion

Add an option module to quickly and easily expand functionality with up to 2 additional PLC-S modules.



### High Reliability

Shares reliability standards with other CIMON PLC series (internal test standard).



### Speed

- Max 32 PID loop control.
- Equipped with 16 kpps high-speed counter.
- 2-axis servo control embedded.

Sold & Serviced By:

Canadian and International Sales  
 **ELECTROMATE**  
 877-737-8698  
 sales@electromate.com  
 www.electromate.com

U.S. Sales  
 **SERVO2GO.com**  
 877-378-0240  
 sales@servo2go.com  
 www.servo2go.com

# XPANEL HYBRID SPECIFICATIONS

## PRODUCT SPECIFICATIONS

### General Specification

Items	Specifications	Standards																					
Operating Temperature	-10–60°C	-																					
Non-Operating Temperature	-25–70°C	-																					
Operating Humidity	10–95% RH, No condensation	-																					
Non-Operating Humidity	10–95% RH, No condensation	-																					
Vibration Resistance	<table border="1"> <thead> <tr> <th rowspan="2">Frequency (pps)</th> <th colspan="2">Continuous Vibration</th> <th colspan="2">Intermittent Vibration</th> <th rowspan="2">Count</th> </tr> <tr> <th>Acceleration (m/s<sup>2</sup>)</th> <th>Amplitude (mm)</th> <th>Acceleration (m/s<sup>2</sup>)</th> <th>Amplitude (mm)</th> </tr> </thead> <tbody> <tr> <td>5 ≤ f &lt; 9, 9 ≤ f ≤ 150 pps</td> <td>-</td> <td>1.75</td> <td>-</td> <td>3.5</td> <td rowspan="2">10 times for each direction X, Y, Z</td> </tr> <tr> <td>9 ≤ f ≤ 150 pps</td> <td>4.9 (0.5 G)</td> <td>-</td> <td>9.8 (1 G)</td> <td>-</td> </tr> </tbody> </table>	Frequency (pps)	Continuous Vibration		Intermittent Vibration		Count	Acceleration (m/s <sup>2</sup> )	Amplitude (mm)	Acceleration (m/s <sup>2</sup> )	Amplitude (mm)	5 ≤ f < 9, 9 ≤ f ≤ 150 pps	-	1.75	-	3.5	10 times for each direction X, Y, Z	9 ≤ f ≤ 150 pps	4.9 (0.5 G)	-	9.8 (1 G)	-	IEC 61131-2
	Frequency (pps)		Continuous Vibration		Intermittent Vibration			Count															
		Acceleration (m/s <sup>2</sup> )	Amplitude (mm)	Acceleration (m/s <sup>2</sup> )	Amplitude (mm)																		
5 ≤ f < 9, 9 ≤ f ≤ 150 pps	-	1.75	-	3.5	10 times for each direction X, Y, Z																		
9 ≤ f ≤ 150 pps	4.9 (0.5 G)	-	9.8 (1 G)	-																			
Shock Endurance	<ul style="list-style-type: none"> <li>Maximum shock acceleration: 147 m/s<sup>2</sup> (15 G)</li> <li>Duration time: 11 ms</li> <li>Pulse wave: a sine half-wave pulse (3 times for each direction ±X, ±Y, ±Z, total on 3 times)</li> </ul>	IEC 61131-2																					
Noise Immunity	Square Wave Impulse Noise	±2 kV, For 10 consecutive minutes	CIMON Internal Test Standard																				
	Electrostatic Discharge Immunity	Voltage: ±4 kV (Discharge by contact), ±8 kV (Air Discharge)	IEC 61131-2 IEC 61000-4-2																				
	Radiated EMF Noise	80–1,000 MHz, 10 V/m	IEC 61131-2 IEC 61000-4-3																				
	FAST Transient Burst Noise	Power supply	±2 kV	IEC 61131-2 IEC 61000-4-4																			
Digital/Analog input/output (AC)		±2 kV																					
Digital/Analog input/output (DC)		±1 kV																					
Ambient Conditions	Avoid corrosive gas and excessive dust																						
Operating Altitude	≤ 2000 m	IEC61131-2																					
Pollution Level	≤ 2	IEC61131-2																					
Cooling System	Air natural cooling																						

## HMI Part (Xpanel)

Model	HP07CD-DER	HP07CD-DES
LCD Size	7 in	
LCD Type	TFT Color	
Color	65,536 colors	
Resolution	WVGA 800 x 480	
Backlight	LCD	
Luminance	400 cd/m <sup>2</sup>	
Touch Panel	Resistive 4 wire	
Memory	128 MB DDR2	
Storage Space	128 MB SLC NAND Flash	
SD Card	1 SD Slot	
COM1(HMI)	RS-232C/422/485	
COM2(HMI)	RS-232C (internal)	
COM1(PLC)	RS-232C	RS-422/485
COM2(PLC)	RS232C (Internal)	
Ethernet	10/100BASE-T	
USB Host	1 port	
Tool Port	1 USB device	
Audio	1 port	
Voltage	DC 24 V	
Power Consumption	9.6 W	
Operating System	Windows CE 6.0	
Dimension(mm)	185 x 127 x 80.5	
Panel Cut(mm)	177 x 119	
Item Weight	0.85 kg (1.87 lbs)	

## Xpanel Hybrid Product Line-Up

Model	Standard
CM-HP07CD-DER	Xpanel (XT07) + PLC (CPU, RS-232C), DC 24 V, Relay DI 8/DO 8/USB loader, Ethernet, SD card slot
CM-HP07CD-DES	Xpanel (XT07) + PLC (CPU, RS-485), DC 24 V, Relay DI 8/DO 8/USB loader, Ethernet, SD card slot

## Option

Model	Specification
CM-HP-DM	HP07 dummy, for expansion of PLC-S modules
CM-HP-EAA	Analog module for HP07 (AI 2 ch, AO 2 ch) (0–5 V, 1–5 V, 0–10 V, -10–10 V, 0–20 mA, 4–20 mA)
CM-HP-EDR	Digital module for HP07 (DI 7 pts, DO 5 pts [relay])

## PLC-S Part

Items		Descriptions
Power		DC 12–24 V / 10 W (expanded fully in 2 modules)
Program Control		Repetitive operation, Time driven interrupt, Stored program
Method for Controlling Input Output		Indirect method, Direct method by instruction
Program Language		LD (Ladder Diagram), IL (Instruction List), SFC (Sequential Function Chart), FBD (Function Block Diagram)
Data Processing		32-bit
Number of Instruction	Number of Sequence	55
	Number of Application Instruction	389
Execution Processing Speed		200 ns/step for basic instructions
Program Memory		10k steps
Number of I/O Points		384
Operating Modes		RUN, STOP, Remote RUN, Remote STOP
Data Preservation Against Power Failure		Setting data and conservation (latch) in K device
Count of Program Block		128
Blocks of Program (max 127)	Scan	5 types of scan programs including standard scan program, Subroutine, Hot/Cold initialization, Periodic interrupts
	Periodic Interrupts	Up to 15 (min. 10 ms)
	Special Configuration	4 types of special programs including PID program, High-speed counter, Positioning control, Input module filtering
	Comm.	4 types of programs including user protocol program, Modbus RTU master, High Speed PLC Link
	Misc.	SFC Program
Auto Diagnoses		Monitoring delay of processing, Problems of memory, I/O, Battery, Power error
Restarting		Hot restart, Reboot
Expansion		CM-HP-EAA/CM-HP-EDR/CM-HP-DM module + 2 PLC-S modules
Data Memory	X	1024 pts (X0000–X063F)
	Y	1024 pts (Y0000–Y063F)
	M	8192 pts (M0000–M511F)
	L	4096 pts (L0000–L255F)
	K	4096 pts (K0000–K255F)
	F	2048 pts (F0000–F127F)
	T	512 pts (T0000–T0511)
	C	512 pts (C0000–C0511)
	S	100 states x 100 set (00.00–99.99)
	D	10000 words (D0000–D9999)
	Z	1024 words (call stack : Z0000–Z0063, Z1000–Z1063)
	R	16 pts (index)
High-Speed Counter		Maximum count speed 16 kpps, (maximum 4 kpps when using 2 phase 2 ch)



Items	Descriptions
PID	32 ch, Auto-tuning
Real Time Clock	Operated by internal battery (CR2032 backup)
Communication Channel	USB (CICON programming) Option: RS-232C 1 ch or RS-422/485 1 channel
2 Axis	Floating point arithmetic, Modification in RUN status, etc.

## Expansion Modules (PLC-S)

### Digital I/O

Model	Type	Standard
CM3-SP32EDO	DI-32	DI 32 pts, DC 24 V
CM3-SP32EOT	DO-32	DO 32 pts, DC 24 V TR (sink)
CM3-SP32EOC	DO-32	DO 32 pts, DC 24V TR (source)
CM3-SP16EOR	DO-16	DO 16 pts, Relay output
CM3-SP32EDT	DI-16 / DO-16	DI 16 pts, DO 16 pts, TR (sink)

### Analog I/O & Temp. Measuring

Model	Type	Specifications
CM3-SP04EAO	AI-4	AI 4 ch (0–5 V, 1–5 V, 0–10 V, -10–10 V, 0–20 mA, 4–20 mA)
CM3-SP04EAA	AIO-4	AI 2 ch / AO 2 ch (0–5 V, 1–5 V, 0–10 V, -10–10 V, 0–20 mA, 4–20 mA)
CM3-SP04EOAI	AO-4	AO 4 ch current output (4–20 mA)
CM3-SP04EOAV		AO 4 ch voltage output (-10–10 V, 0–10 V)
CM3-SP04ERO	Temperature Measuring	4 pts RTD (PT100, JPT100, PT1000, NI1000)
CM3-SP04ETO		4 pts TC (K, J, E, T, B, R, S, N)

### Communication

Model	Type	Protocols
CM3-SP02ERS	RS-232C 1 ch, RS-422/485 1 ch	CICON, CIMON HMI, Modbus RTU slave & master, Protocol program
CM3-SP02ERR	RS-232C 2 ch	CICON, CIMON HMI, Modbus RTU slave & master, Protocol program
CM3-SP01EET	Ethernet (10/100BASE-TX)	CICON, CIMON HMI, Modbus TCP slave & master, Protocol program, DHCP

### Accessories

Model	Classification	Note
CM0-TB32M	Terminal block	Can be used with following modules: CM3-SP32EDO
CM0-SCB15E	1.5 m cable	

\* For more information about specifications, please refer to the PLC-S catalog.

## Dimensions of CIMON-XPANEL

Unit : mm

### ▶ XT04CD

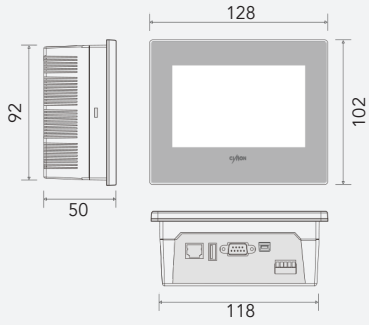

Panel cut

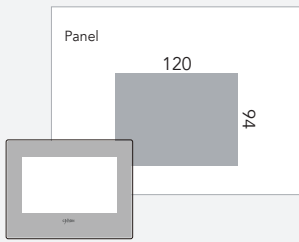

### ▶ XT07CD

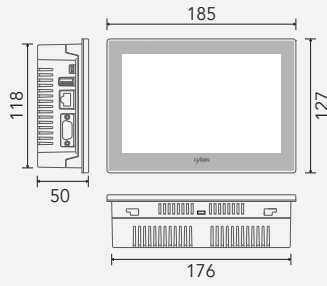

Panel cut

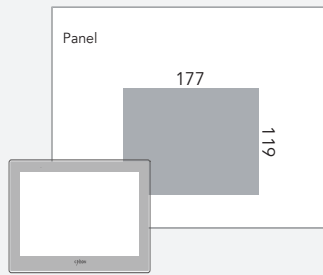

### ▶ HP07CD

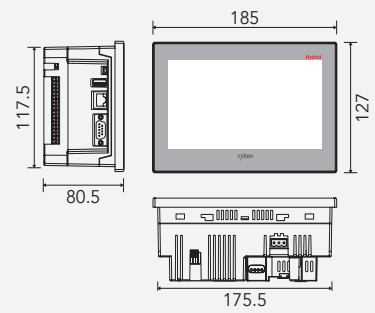

Panel cut

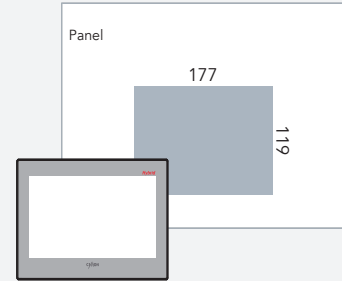

### ▶ iXT10CD

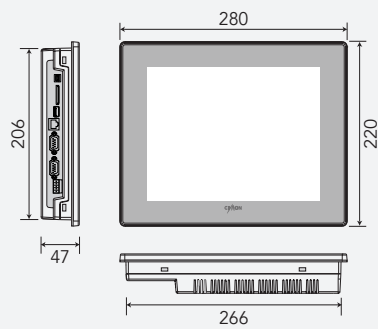

Panel cut

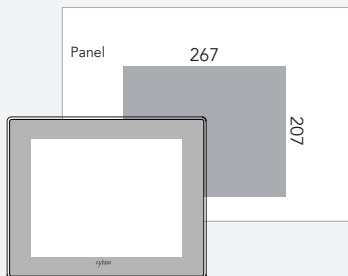

### ▶ iXT12CD

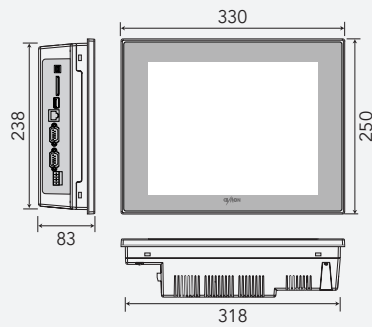

Panel cut

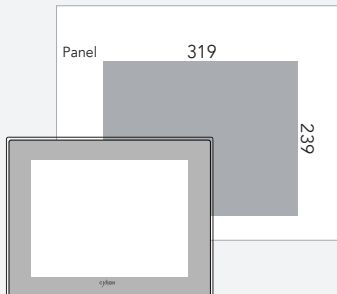

### ▶ iXT15CD

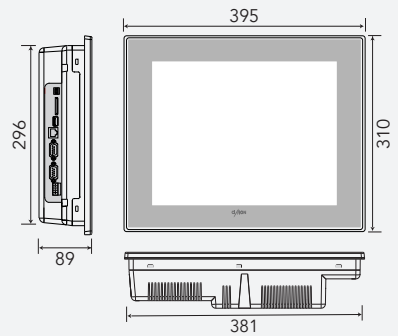

Panel cut

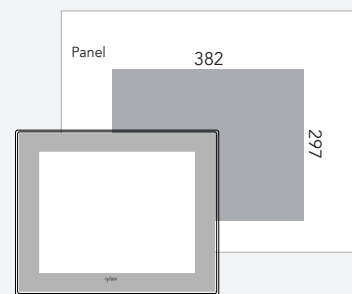

# MEMO

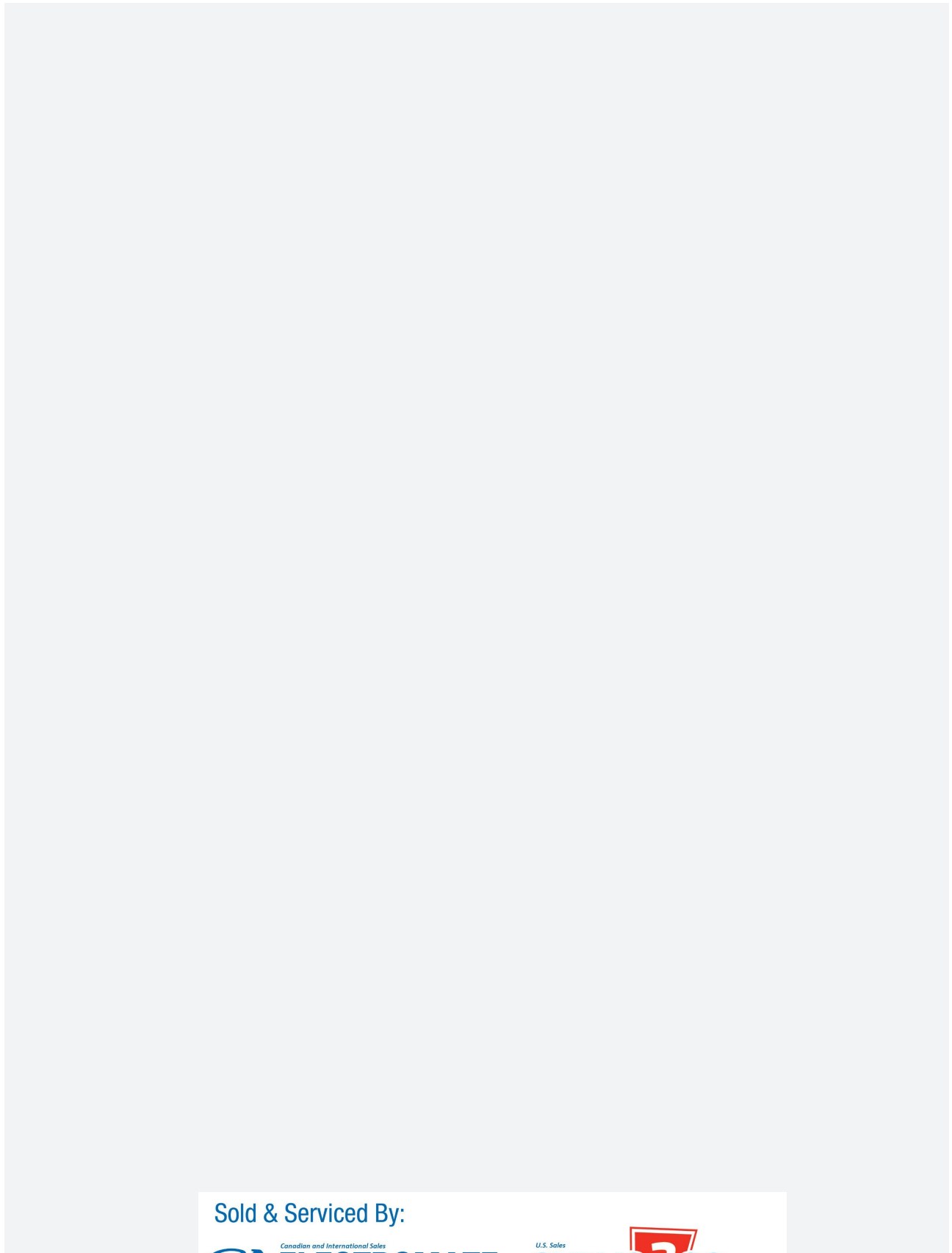

Sold & Serviced By:



Canadian and International Sales

**ELECTROMATE**

877-737-8698  
sales@electromate.com  
www.electromate.com

U.S. Sales

**SERVO2GO.com**

877-378-0240  
sales@servo2go.com  
www.servo2go.com



[www.cimon.com](http://www.cimon.com)

Revision: Ver. 8 Revision Date: DEC 2020 Printed: DEC 2020

Sold & Serviced By:



*Canadian and International Sales*

**ELECTROMATE**

877-737-8698

[sales@electromate.com](mailto:sales@electromate.com)

[www.electromate.com](http://www.electromate.com)

*U.S. Sales*

**SERVO2GO.com**

877-378-0240

[sales@servo2go.com](mailto:sales@servo2go.com)

[www.servo2go.com](http://www.servo2go.com)