

CIMON IPC

INDUSTRIAL PC

- CIMON PANEL PC
- CIMON RACK PC

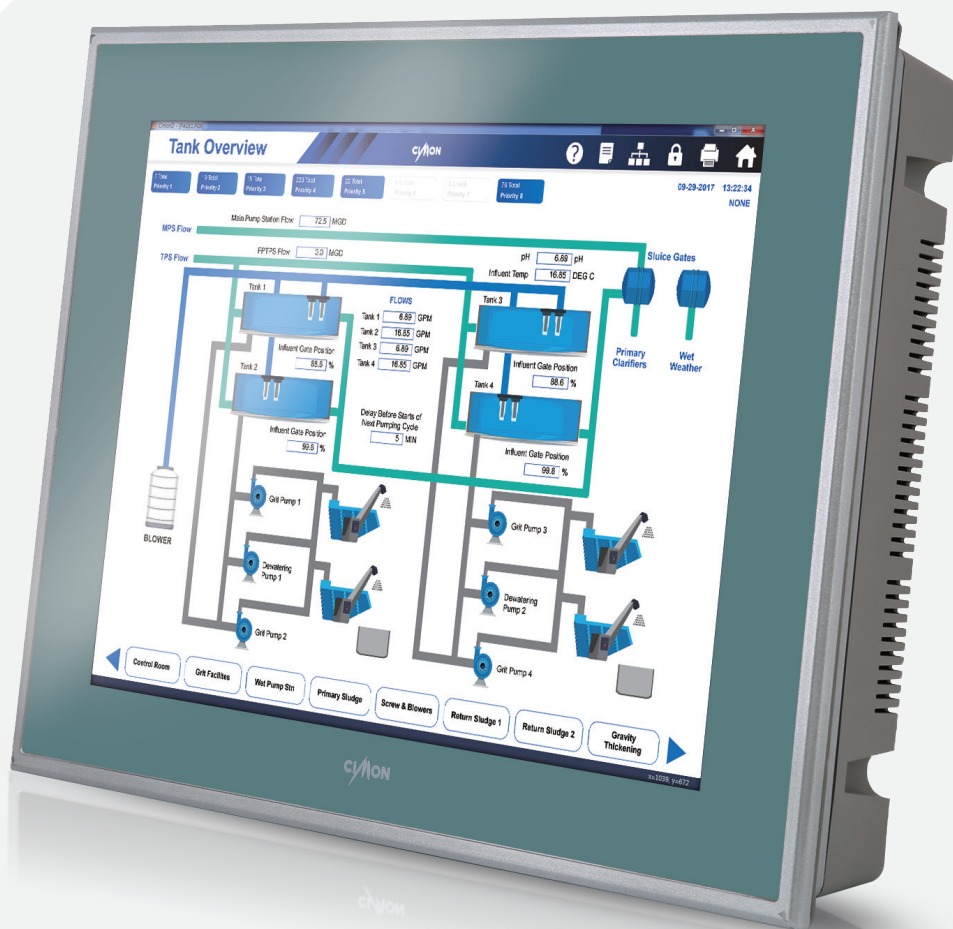

INDUSTRIAL PC



CIMON IPC is an industrial computer device that runs on Windows/Linux OS and an Intel CPU. What makes an industrial PC different from ordinary PCs is that an industrial PC takes into account your automation and controls needs, including device endurance, user experience, and task execution. This goes in tandem with the fact that industrial PCs provide powerful performance in some of the harshest environments, which are not uncommon in and around many factories and facilities. Take advantage of CIMON IPC's strength and speed to improve operational efficiency at your establishment.



NO.	DESCRIPTION	UNIT	QTY	DATE	STATUS
1	ITEM 1	KG	100	2024-10-27	OK
2	ITEM 2	LITER	50	2024-10-27	OK
3	ITEM 3	BOX	20	2024-10-27	OK
4	ITEM 4	UNIT	10	2024-10-27	OK
5	ITEM 5	UNIT	5	2024-10-27	OK
6	ITEM 6	UNIT	3	2024-10-27	OK
7	ITEM 7	UNIT	2	2024-10-27	OK
8	ITEM 8	UNIT	1	2024-10-27	OK
9	ITEM 9	UNIT	1	2024-10-27	OK
10	ITEM 10	UNIT	1	2024-10-27	OK

PRODUCT PERFORMANCE

CIMON PANEL PC

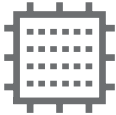

SSD and CPU Lineup

Fast start-up and processing speeds plus greater product functioning with Intel J1900/i3-6100U/i5-6300U processors



Proven Reliability

FCC, CE, UL, cUL, IP65, IECEx certified* and NEMA 4X rated for demonstrated durability and dependability

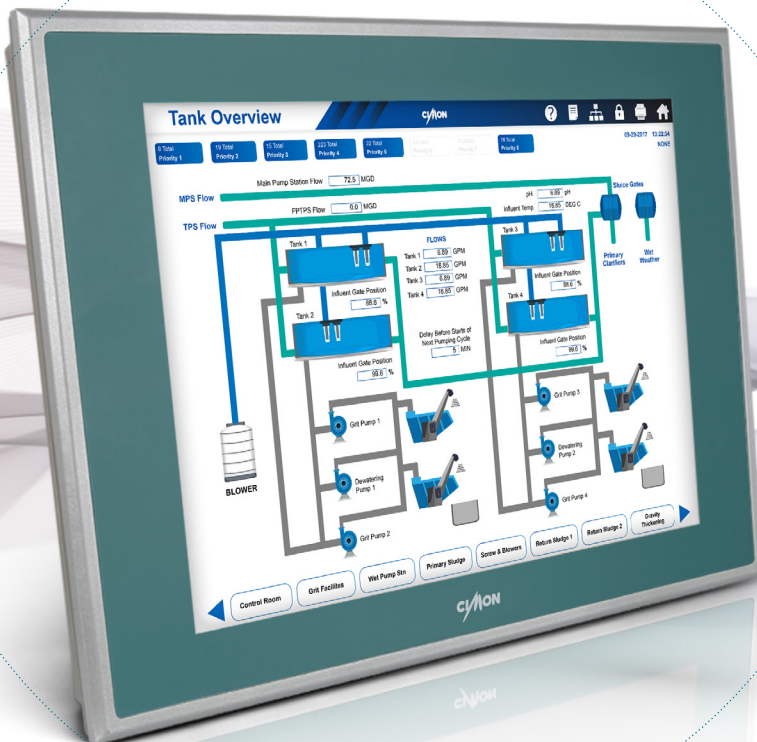

Heat and Energy Management

Extremely low power consumption of 16 W,* impressive thermal dissipation to maintain device equilibrium, and a fanless design to preserve device longevity

Variety of Interfaces

Includes 2 gigabit Ethernet ports, up to 4 serial ports,* and up to 4 USB 3.0 ports*



Sold & Serviced By:

Canadian and International Sales
ELECTROMATE
877-737-8698
sales@electromate.com
www.electromate.com

U.S. Sales
SERVO2GO.com
877-378-0240
sales@servo2go.com
www.servo2go.com



Disk Drive Preservation

UWF and EWF features* enhance device security and provide the means for increased device survivability by implementing restrictions. Prevent the unauthorized use of disk volume, including the installation of undesirable software or changes to system settings, and allow a fresh, clean slate when using CIMON Panel PC



System Integrity

RAID 1 configuration* mirrors your information onto a separate disk so your information is safe and ready for restoration in case of a critical error. A one-click Winclone solution* can back up your data when needed, and hot swap storage* allows you to exchange disk drives while servers are still up and running, reducing both cost and downtime.

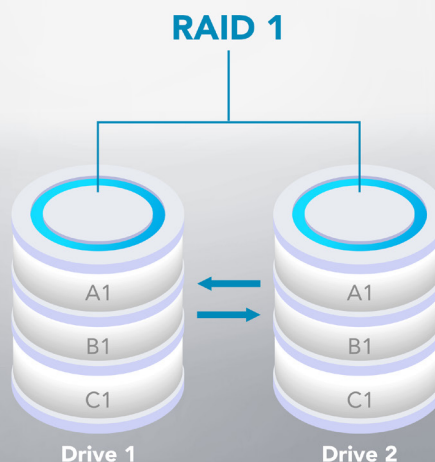

Industrial Strength

CIMON Panel PC can handle severe environments, from humid to dry and from hot to cold. Aluminum die-casted casings* provide intense durability thanks to improved shock and vibration resistance technology along with stellar heat dissipation.



Array of Operating Systems

Stay compliant, secure, and confident with well-known and reputable OS versions such as Windows Embedded Standard 7, Windows 10 IoT Enterprise, Windows 10 Professional, and Linux, all while displaying your projects in virtually any language with the multilingual user interface (MUI) package.**

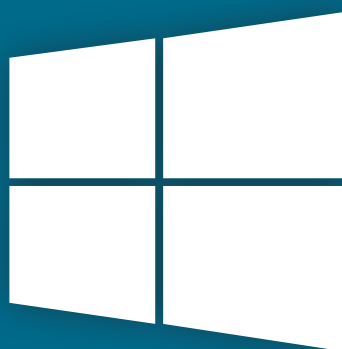

*Applies only to select models

**Applies only to select operating systems

Sold & Serviced By:



Canadian and International Sales

ELECTROMATE

877-737-8698

sales@electromate.com

www.electromate.com

U.S. Sales

SERVO2GO.com

877-378-0240

sales@servo2go.com

www.servo2go.com

PRODUCT PERFORMANCE

CIMON RACK PC

CIMON Rack PC features the 1U- and 4U-sized casings with a fanless design.*

This industrial computer can be used in various sites where reliability, resistance to dust, and low power consumption are most important.



Impressive Performance

Start with 128 GB of SSD storage,** up to 32 GB of RAM, and your choice of an Intel J1900/i5-6500/i7-6700 CPU*



Extensive Connectivity

Take advantage of compatibility and communications with 2 gigabit Ethernet ports, up to 8 USB ports,* and Mini PCIe slots* for maximum effectiveness



Project Stability

EFW,* UWF,* Winclone,* and RAID 1* keep your sensitive information secure from unauthorized users and ready for any needed restoration

Energy Efficient

Work on your industrial projects with as little as 13 W* of power consumption, allowing for a smooth workflow while saving energy and costs over time



*Applies only to select models

**Storage expansion available upon request

Sold & Serviced By:

Canadian and International Sales
 **ELECTROMATE**
 877-737-8698
 sales@electromate.com
 www.electromate.com

U.S. Sales
 **SERVO2GO.com**
 877-378-0240
 sales@servo2go.com
 www.servo2go.com

Data Protection

Secure data is crucial for business operations.. CIMON Rack PC comes with built-in measures to increase reliability. Our RAID 1 protocol* replicates and stores your information on multiple disks, allowing you to keep your projects safe and intact in case one disk suffers a critical error.



Agility and Adaptability

Machine downtime that halts business production can be frustrating and costly. However, with hot swap storage,* you can easily replace hard drives while the servers are live and operational, resulting in zero downtime for your business.



Superb Scalability

Just as project sizes may vary, so too do our rack PCs. For projects that require a more compact device, choose a 1U-sized model. For projects that require additional capability at the expense of space, choose a larger 4U-sized model.



Longevity and Dependability

Our rack PCs are designed with fanless systems* and metal casings to reduce noise pollution and extend the overall lifespan of the device, allowing you to enjoy peak performance for a greater amount of time.



Sold & Serviced By:

*Applies only to select models



Canadian and International Sales

ELECTROMATE

877-737-8698

sales@electromate.com

www.electromate.com

U.S. Sales

SERVO2GO.com

877-378-0240

sales@servo2go.com

www.servo2go.com

PRODUCT CONFIGURATION

SYSTEM LAYOUT

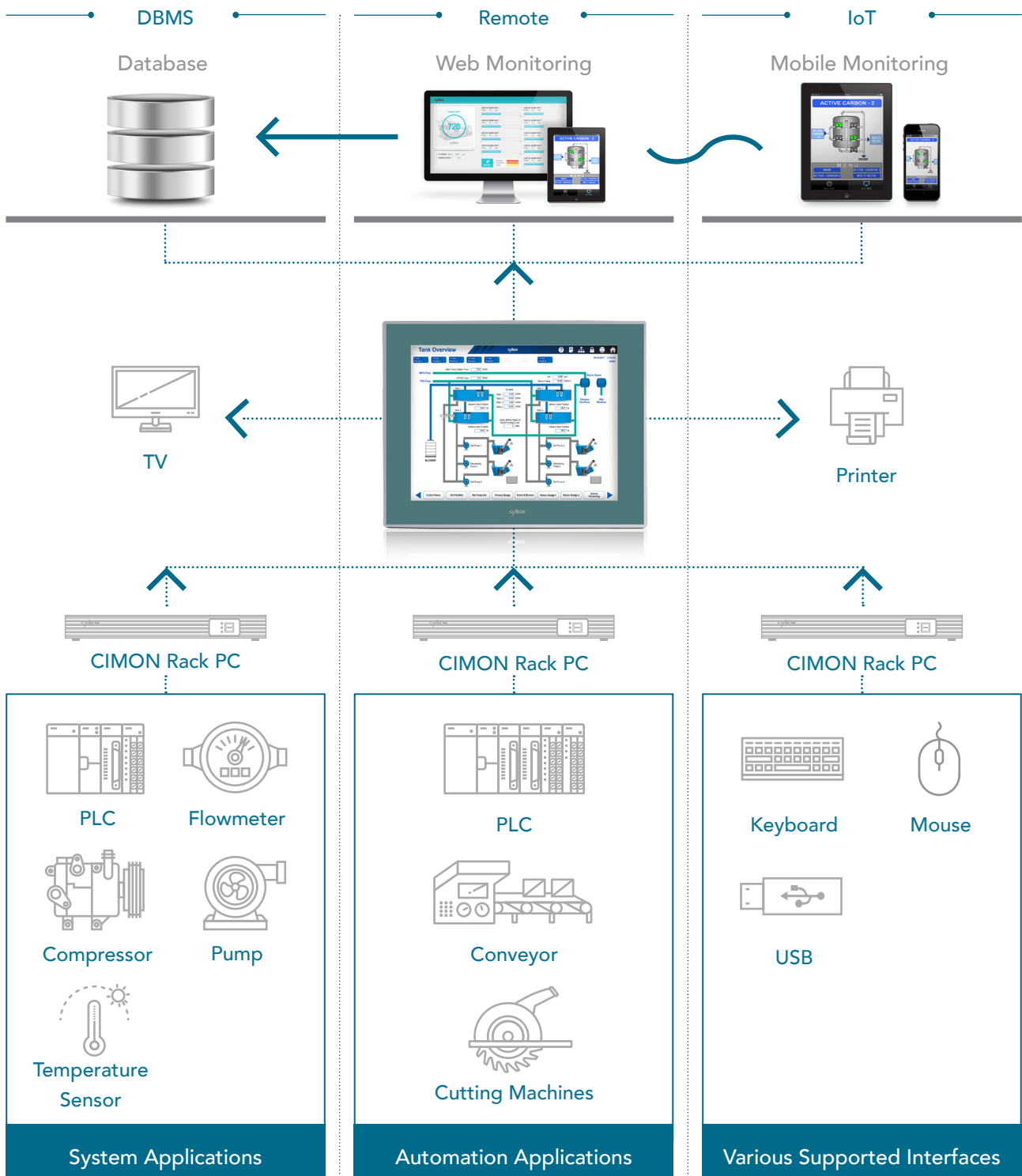

DBMS

Remote

IoT

Database

Web Monitoring

Mobile Monitoring



TV



Printer



CIMON Rack PC



CIMON Rack PC



CIMON Rack PC

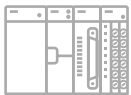

PLC



Flowmeter



Compressor

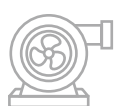

Pump



Temperature Sensor

System Applications

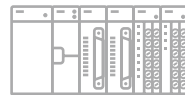

PLC



Conveyor



Cutting Machines

Automation Applications



Keyboard



Mouse



USB

Various Supported Interfaces

CIMON IPC SPECIFICATIONS

PRODUCT DETAILS

The CIMON IPC series provides an extensive range of robust and reliable industrial PCs. All panel PC and rack PC products are rigorously tested and professionally designed to withstand harsh industrial conditions.

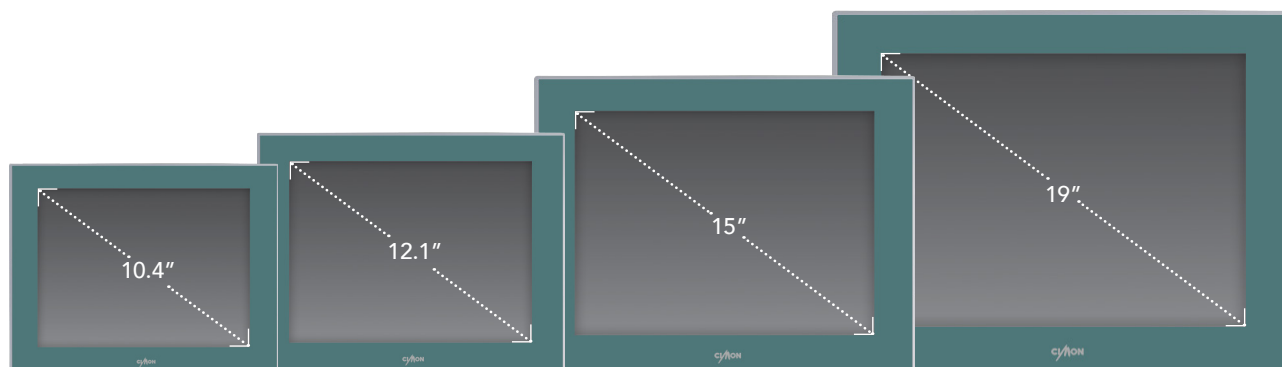

Fanless design and low power consumption	Windows 10 IoT Enterprise OS (default)
Aluminum die-casted case	UWF/EFW program for protection of the OS
Sunlight readable option available	Serial, Ethernet (10/100/1000 BASE-T), VGA/DVI-D, HDMI/DP/DVI-D
Scratch-resistant touchscreen	Capactive touch option available
LED BLU maximizes screen lifecycle	Easy connection with other control devices

Rack and Panel PC

Item	Specification	Item	Specification
INPUT VOLTAGE	DC 24 V or AC 100–240 V (50/60 Hz)	DUST	≤0.1 mg/m ³
OPERATING TEMPERATURE	0 °C–50 °C	POLLUTION	Pollution Degree 2
STORAGE TEMPERATURE	-20 °C–60 °C	AIR CONDITION	Avoid corrosive gas and excessive dust
OPERATING HUMIDITY	Relative humidity 10%–85% at 29 °C (non-condensing)	VIBRATION RESISTANCE	Device with SSD storage: 9.8m/s ² (1 G), 10 Hz–25 Hz in X, Y, Z (80 minutes)
STORAGE HUMIDITY	Relative humidity 10%–85% at 39 °C (non-condensing)	NOISE RESISTANCE	Impulse, EFT/Burst transients, surge, ±2 kV, 1 μs (IEC 61000-4-4)
ENVIRONMENT CONDITION	800 hPa–1114 hPa (below 2000 m)	ELECTROSTATIC DISCHARGE IMMUNITY	±4 kV contact discharge, ±8 kV air discharge (IEC 61000-4-2)

Panel PC

	CM-iNP411-D (DC) CM-iNP411-A (AC)	CM-iNP412-D (DC) CM-iNP412-A (AC)	CM-iNP415-D (DC) CM-iNP415-A (AC)	CM-NP419-D (DC) CM-NP419-A (AC)
CPU	Intel® Celeron® J1900 2.0 GHz			
MEMORY	4 GB (max. 8 GB) DDR3L RAM			
GRAPHIC	Integrated Intel HD Graphic			
DISPLAY	10.4" TFT LCD	12.1" TFT LCD	15" TFT LCD	19" TFT LCD
RESOLUTION	1024 × 768 (XGA)			1280 × 1024 (SXGA)
LCD BRIGHTNESS	600 cd/m ²	700 cd/m ²	450 cd/m ²	550 cd/m ²
BACKLIGHT UNIT	LED			
TOUCH	Analog resistive			
STORAGE	1 × SSD 128 GB			
EX. STORAGE	1 × SATA			
SERIAL	1 × RS-232/422/485, 1 × RS-232	1 × RS-232/422/485, 2 × RS-232, 1 × RS-422/485		
ETHERNET	2 × Gigabit Ethernet			
USB	2 × USB 2.0, 1 × USB 3.0			1 × Front USB 2.0, 2 × Rear USB 2.0, 1 × USB 3.0
AUDIO	1 × Line-out, 1 × Mic-in			
EX. VIDEO	VGA/DVI			
HOT SWAP/RAID 1	N/A			Supported
OS (SELECTABLE)	Windows 10 IoT Enterprise (default)/Windows 10 Pro/Windows 10 Enterprise/ Windows Embedded Standard 7/Linux			
UTILITY PROGRAM	Winclone 6 and UWF (Windows 10)/EWF (Windows 7)			
POWER CONSUMPTION	16 W	21 W	23 W	25 W
INPUT VOLTAGE	AC models (CM-iNPxxx-A): AC 100–240 V, 50/60 Hz; DC models (CM-iNPxxx-D): DC 24 V			
ENCLOSURE	Front case: aluminum, Rear case: plastic			Plastic
WEIGHT	3 kg (6.61 lb)	3.8 kg (8.38 lb)	4.9 kg (10.8 lb)	7.5 kg (16.53 lb)

	CM-iNP3612-D (DC) CM-iNP3612-A (AC)	CM-iNP3615-D (DC) CM-iNP3615-A (AC)	CM-iNP5615-D (DC) CM-iNP5615-A (AC)	CM-NP5619-D (DC) CM-NP5619-A (AC)
CPU	Intel® i3-6100U		Intel® i5-6300U	
MEMORY	8 GB (max. 16 GB) DDR4 SO-DIMM			
GRAPHIC	Integrated Intel HD Graphic			
DISPLAY	12.1" TFT LCD	15" TFT LCD	15" TFT LCD	19" TFT LCD
RESOLUTION	1024 × 768 (XGA)			1280 × 1024 (SXGA)
LCD BRIGHTNESS	700 cd/m ²	450 cd/m ²	450 cd/m ²	550 cd/m ²
BACKLIGHT UNIT	LED			
TOUCH	Analog resistive			
STORAGE	1 × SSD 128 GB			
EX. STORAGE	1 × SATA			
SERIAL	1 × RS-232/422/485, 2 × RS-232	1 × RS-232/422/485, 3 × RS-232		
ETHERNET	2 × Gigabit Ethernet			
USB	4 × USB 3.0			1 × Front USB 2.0, 4 × Rear USB 3.0
AUDIO	1 × Line-out			
EX. VIDEO	1 × HDMI/DP			
HOT SWAP/RAID 1	N/A			Supported
OS (SELECTABLE)	Windows 10 IoT Enterprise (default)/Windows 10 Pro/Windows 10 Enterprise/ Windows Embedded Standard 7/Linux			
UTILITY PROGRAM	Winclone 6 and UWF (Windows 10)/EWF (Windows 7)			
POWER CONSUMPTION	17 W	20 W	25 W	30 W
INPUT VOLTAGE	AC models (CM-iNPxxxx-A): AC 100–240 V, 50/60 Hz; DC models (CM-iNPxxxx-D): DC 24 V			
ENCLOSURE	Aluminum			Plastic
WEIGHT	4.5 kg (9.92 lb)	5.2 kg (11.46 lb)	5.2 kg (11.46 lb)	6.5 kg (14.33 lb)



Rack PC

Specification	CM-NU1RB-A	CM-NU4R56-A	CM-NU4R76-A
CPU	Intel® Celeron® J1900 2.0 GHz (fanless)	Intel® Core™ i5-6500 3.2 GHz	Intel® Core™ i7-6700 3.4 GHz
MEMORY	4 GB (max. 8 GB) DDR3L RAM	8 GB (4 × slot, max. 32 GB) DDR4 DIMM	
GRAPHIC	Integrated Intel HD Graphic		
STORAGE	1 × SSD 128 GB	1 × SSD 256 GB	
EX. STORAGE	1 × mSATA	5 × SATA	
SERIAL	1 × RS-232/422/485, 1 × RS-232	1 × RS-232/422/485, 1 × RS-232 (max. 4 × RS-232)	
ETHERNET	2 × Gigabit Ethernet	2 × Gigabit Ethernet	
USB	2 × Front USB 2.0, 2 × Rear USB 2.0, 1 × USB 3.0,	2 × Front USB 2.0, 6 × Rear USB 3.0	
AUDIO	1 × Line-in/Mic-in	1 × Line-in/Line-out/Mic-in	
EX. VIDEO	1 × VGA/DVI-D	1 × HDMI/DP/DVI-D	
PCI-E	1 × Mini PCIe	1 × PCI-E (x16), 1 × PCI-E (x8), 1 × PCI-E (x4), 1 × PCI-E (x1), 3 × PCI	
HOT SWAP/RAID 1	N/A	Supported	
OS (SELECTABLE)	Windows 10 IoT Enterprise (default)/Windows 10 Pro/Windows 10 Enterprise/ Windows Embedded Standard 7/Linux		
UTILITY PROGRAM	Winclone 6 and UWF (Windows 10)/EWF (Windows 7)		
POWER CONSUMPTION	13 W	33 W	38 W
INPUT VOLTAGE	AC 100–240 V, 50/60 Hz		
WEIGHT	3.8 kg (8.38 lb)	16.1 kg (35.49 lb)	

Panel PC Diagrams

CM-iNP411

10.4-inch model

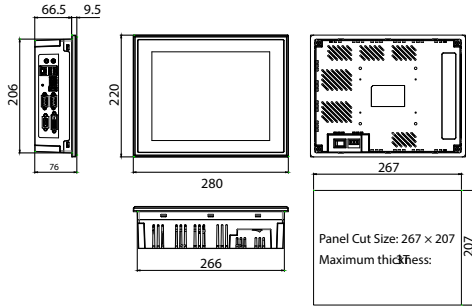

CM-iNP412

12.1-inch model

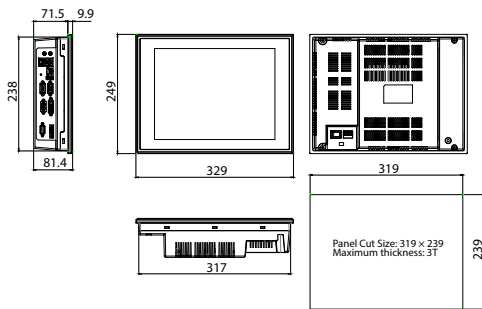

CM-iNP3612

12.1-inch model

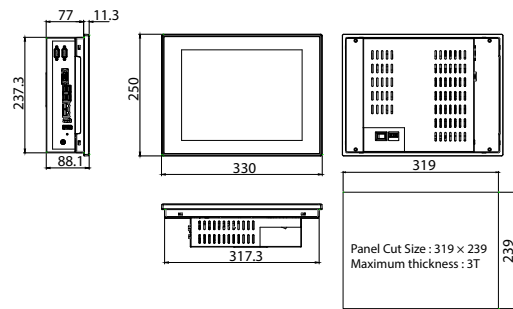

CM-iNP415

15-inch model

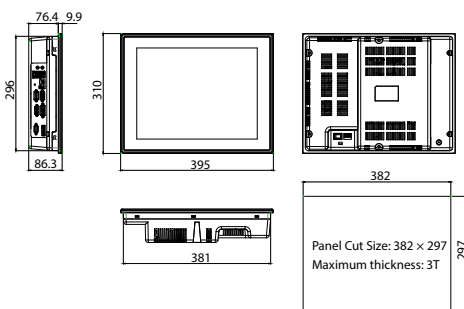

CM-iNP3615, CM-iNP5615

15-inch models

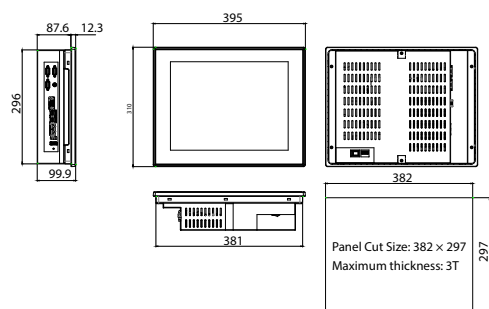

CM-NP419

19-inch model

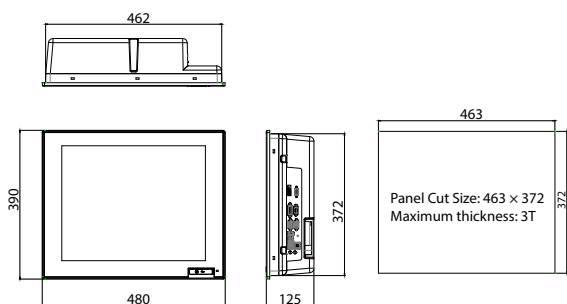

CM-NP5619

19-inch model

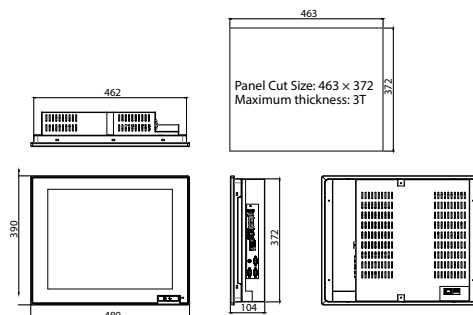

Panel PC I/O Plates

CM-iNP411 I/O Plate

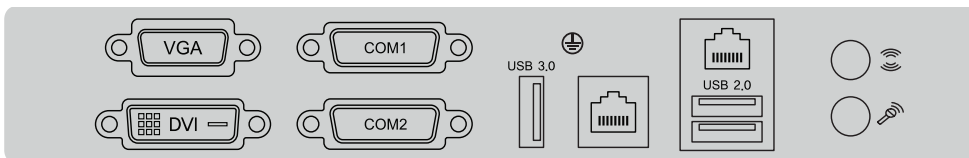

CM-iNP412, CM-iNP415, CM-NP419 I/O Plate

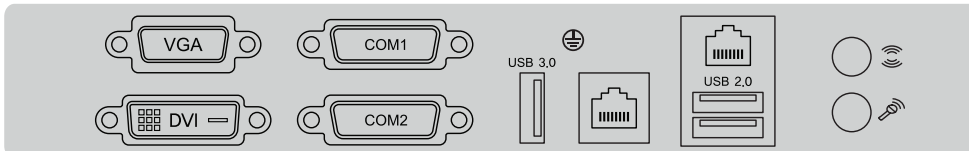

CM-iNP3612 I/O Plate

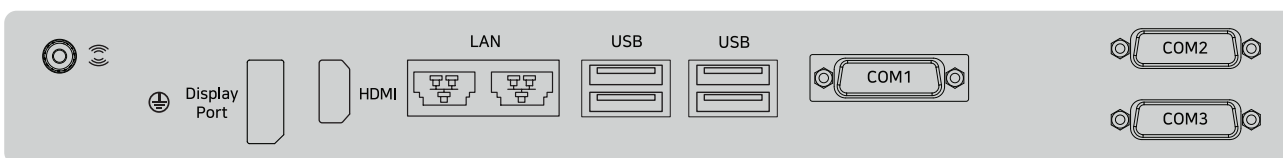

CM-iNP3615, CM-iNP5615, CM-NP5619 I/O Plate

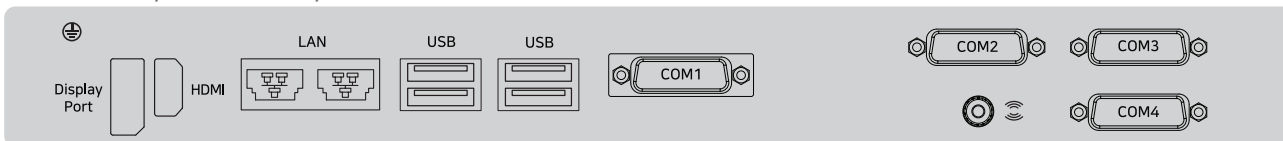

Rack PC I/O Plates

CM-NU1R, CM-NU2R I/O Plate

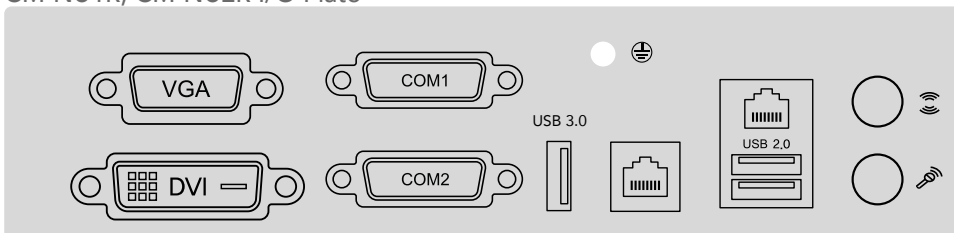

CM-NU4R I/O Plate

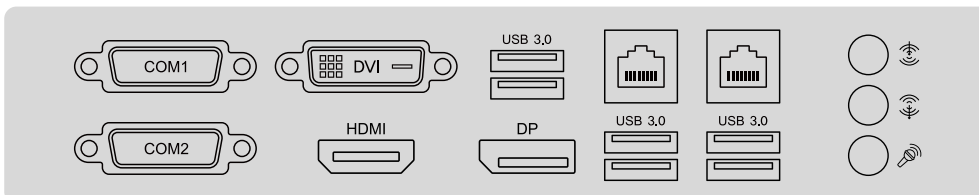

Sold & Serviced By:

Canadian and International Sales
 **ELECTROMATE**
 877-737-8698
 sales@electromate.com
 www.electromate.com

U.S. Sales

 877-378-0240
 sales@servo2go.com
 www.servo2go.com

CIMON PANEL PC LINEUP

Model	Description
CM-iNP411-A	Intel J1900, 10.4" (1024 × 768), 128 GB SSD, 4 GB DDR3L RAM, 2 × serial, 2 × Ethernet, 3 × USB, AC 100–240 V (50/60 Hz)
CM-iNP411-D	Intel J1900, 10.4" (1024 × 768), 128 GB SSD, 4 GB DDR3L RAM, 2 × serial, 2 × Ethernet, 3 × USB, DC 24 V
CM-iNP412-A	Intel J1900, 12.1" (1024 × 768), 128 GB SSD, 4 GB DDR3L RAM, 4 × serial, 2 × Ethernet, 3 × USB, AC 100–240 V (50/60 Hz)
CM-iNP412-D	Intel J1900, 12.1" (1024 × 768), 128 GB SSD, 4 GB DDR3L RAM, 4 × serial, 2 × Ethernet, 3 × USB, DC 24 V
CM-iNP415-A	Intel J1900, 15" (1024 × 768), 128 GB SSD, 4 GB DDR3L RAM, 4 × serial, 2 × Ethernet, 3 × USB, AC 100–240 V (50/60 Hz)
CM-iNP415-D	Intel J1900, 15" (1024 × 768), 128 GB SSD, 4 GB DDR3L RAM, 4 × serial, 2 × Ethernet, 3 × USB, DC 24 V
CM-NP419-A	Intel J1900, 19" (1280 × 1024), 128 GB SSD, 4 GB DDR3L RAM, 4 × serial, 2 × Ethernet, 4 × USB, AC 100–240 V (50/60 Hz)
CM-NP419-D	Intel J1900, 19" (1280 × 1024), 128 GB SSD, 4 GB DDR3L RAM, 4 × serial, 2 × Ethernet, 4 × USB, DC 24 V
CM-iNP3612-A	Intel Core i3-6100U, 12.1" (1024 × 768), 128 GB SSD, 8 GB DDR4 RAM, 3 × serial, 2 × Ethernet, 4 × USB, AC 100–240 V (50/60 Hz)
CM-iNP3612-D	Intel Core i3-6100U, 12.1" (1024 × 768), 128 GB SSD, 8 GB DDR4 RAM, 3 × serial, 2 × Ethernet, 4 × USB, DC 24 V
CM-iNP3615-A	Intel Core i3-6100U, 15" (1024 × 768), 128 GB SSD, 8 GB DDR4 RAM, 4 × serial, 2 × Ethernet, 4 × USB, AC 100–240 V (50/60 Hz)
CM-iNP3615-D	Intel Core i3-6100U, 15" (1024 × 768), 128 GB SSD, 8 GB DDR4 RAM, 4 × serial, 2 × Ethernet, 4 × USB, DC 24 V
CM-iNP5615-A	Intel Core i5-6300U, 15" (1024 × 768), 128 GB SSD, 8 GB DDR4 RAM, 4 × serial, 2 × Ethernet, 4 × USB, AC 100–240 V (50/60 Hz)
CM-iNP5615-D	Intel Core i5-6300U, 15" (1024 × 768), 128 GB SSD, 8 GB DDR4 RAM, 4 × serial, 2 × Ethernet, 4 × USB, DC 24 V
CM-NP5619-A	Intel Core i5-6300U, 19" (1280x1024), 128 GB SSD, 8 GB DDR4 RAM, 4 × serial, 2 × Ethernet, 5 × USB, AC 100–240 V (50/60 Hz), hot swap/RAID 1 supported
CM-NP5619-D	Intel Core i5-6300U, 19" (1280x1024), 128 GB SSD, 8 GB DDR4 RAM, 4 × serial, 2 × Ethernet, 5 × USB, DC 24 V, hot swap/RAID 1 supported

CIMON RACK PC LINEUP

Model	Description
CM-NU1RB-A	1U rack type, Intel J1900, 128 GB SSD, 4 GB DDR3L RAM, 1 × Mini PCIe, 2 × serial, 2 × Ethernet, 5 × USB, AC 100–240 V (50/60 Hz)
CM-NU4R56-A	4U rack type, Intel i5-6500, 256 GB SSD, 8 GB DDR4 RAM, 1 × PCIe (x16), 1 × PCIe (x8), 1 × PCIe (x4), 1 × PCIe (x1), 3 × PCI, 2 × serial, 2 × Ethernet, 8 × USB, AC 100–240 V (50/60 Hz), hot swap/RAID 1 supported
CM-NU4R76-A	4U rack type, Intel i7-6700, 256 GB SSD, 8 GB DDR4 RAM, 1 × PCIe (x16), 1 × PCIe (x8), 1 × PCIe (x4), 1 × PCIe (x1), 3 × PCI, 2 × serial, 2 × Ethernet, 8 × USB, AC 100–240 V (50/60 Hz), hot swap/RAID 1 supported

Sold & Serviced By:



Canadian and International Sales

ELECTROMATE

877-737-8698

sales@electromate.com

www.electromate.com

U.S. Sales

SERVO2GO.com

877-378-0240

sales@servo2go.com

www.servo2go.com



www.cimon.com

Revision Date: DEC 2020 Printed: OCT 2020
