

BWC

Motion Without Limits®

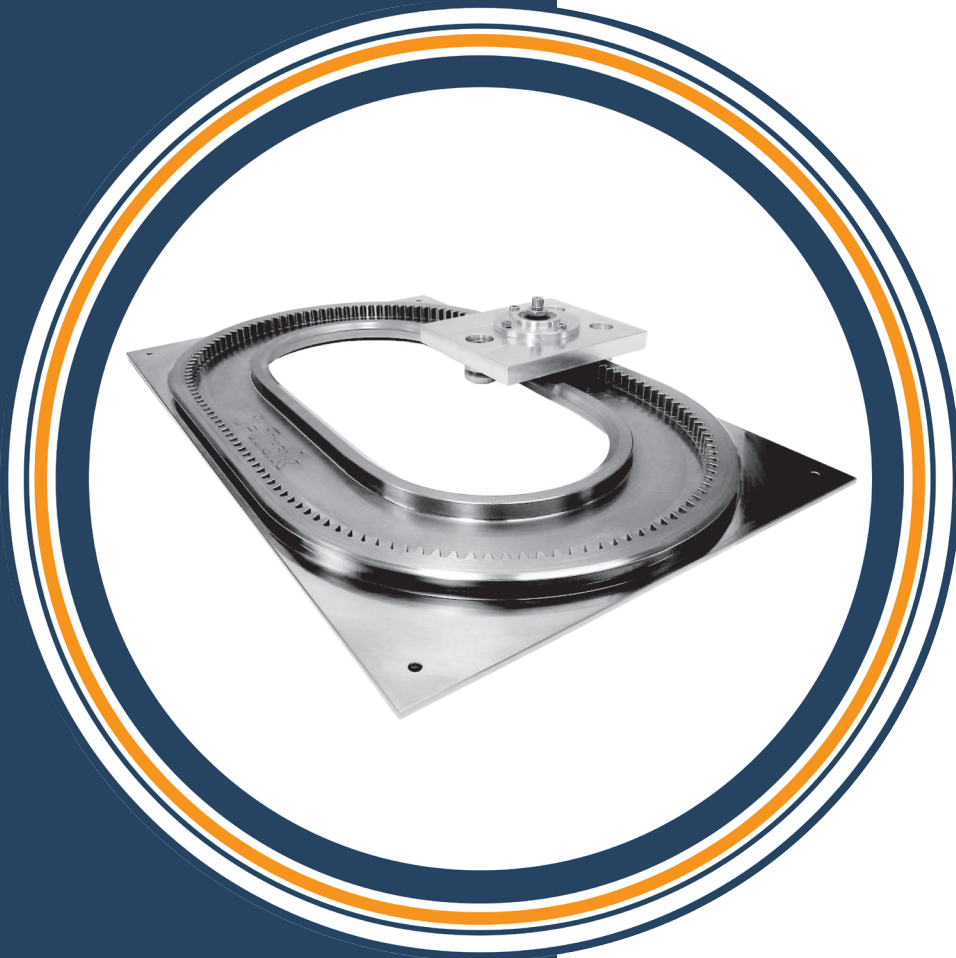

PRT2 1-TRAK

PRT2 1-Trak is an innovative guided motion system that further enhances the acclaimed HepcoMotion® **PRT2** range of ring and track solutions. **1-Trak**, a single piece track system, is completely seamless and free running with no possibility of misalignment during installation or in service, resulting in smoother, quieter motion.

Sold & Serviced By:



Toll Free Phone (877) SERV098

Toll Free Fax (877) SERV099

www.electromate.com

sales@electromate.com

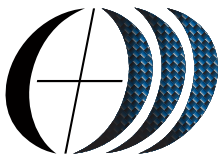

BISHOPWISECARVER GROUP
A FAMILY OF SOLUTIONS

Located in the historic California steel town of Pittsburg, today's bustling 85,000 square-foot facility is a far cry from the humble Oakland machine shop where the company's founder got his start in the 1950s.

Bishop-Wisecarver Group is a woman-owned family of WBENC certified companies who works with manufacturers to engineer, produce, and build custom complex assemblies, linear motion solutions and optimal embedded intelligence systems. Through the integration of our mechanical, electronic, software, control and systems design engineering expertise (mechatronics), 60+ years of experience, and 20,000+ unique clients, we continue to provide a single point of service that results in custom designs, increased efficiencies, and accelerated time to market.

BWC

Bishop-Wisecarver Corporation helps manufacturers and automation solution providers engineer linear and rotary motion solutions. With 60+ years of engineering expertise and manufacturing best practices working with over 20,000 customers, we understand our customers' design and application requirements which enables us to develop unique solutions that typically ship within 2 to 3 weeks. Customers achieve 50% faster time to market, up to 50-75% lower maintenance and installed costs, product differentiation, and longer product life.

WRW

WRW Engineering helps companies integrate mechanical, electrical and software engineering to deliver custom mechatronic solutions. By understanding the interplay between these three disciplines, we design and develop optimal embedded intelligence systems such as automated flexible testing stations, smart products, and autonomous machines. Through this holistic approach, our customers realize higher production efficiencies, faster time to market, and increased revenues.

BDM

Black Diamond Manufacturing is a specialty contract manufacturer of complex electro-mechanical sub-assemblies providing a single source solution from design to full production resulting in lower overall costs. BDM is different from other manufacturers because they have the ability to scale from prototype work to full production, and the ability to manage the customer's supply chain and hold consignment inventory. With 60+ years of in-house manufacturing experiences and capabilities BDM provides solutions for custom sub-assemblies.

Sold & Serviced By:



Toll Free Phone (877) SERV098

Toll Free Fax (877) SERV099

www.electromate.com

sales@electromate.com

APPLICATION DATA SHEET

Company Name: _____

Contact Name: _____

Address: _____

City: _____ State: _____ Zip Code: _____

Phone: _____ Fax: _____

E-Mail: _____

I would like to receive the monthly e-newsletter (please check): Y N

System Orientation: _____ horizontal vertical

Load: _____ lbs N

Stroke Length: _____ in m

Velocity: _____ in/s m/s

Accel/Decel: _____ in/s² m/s²

Linear Accuracy: _____ in/ft mm/m

Repeatability: _____ in m

Duty Cycle: _____ in/day m/day

Environment: _____

Temperature: _____ °F °C

Additional Forces: _____ lbs N

Application Description: _____

Design Challenge/Issues to Solve: _____

Current Design Strengths to be Reinforced/Maximized: _____

Market/Competitive Advantage Opportunities to be Gained: _____

Expected Volume: _____

Sold & Serviced By:



Headline:
Toll Free Phone (877) SERV098
Toll Free Fax (877) SERV099
www.electromate.com
sales@electromate.com

Table of CONTENTS

PRODUCT INFORMATION

- Introduction.....1
- One Piece Tracks With Integral Base Plate.....2
- Three Bearing Carriage Geometry.....3
- Track Systems with Complete Size Flexibility.....4
- Track Systems with Rack and Pinion Drive.....5
- Track Systems Used in Parallel.....6
- How to Specify a PRT2 1-Trak System.....7
- How to Specify a PRT2 1-Trak System.....8



PRT2 1-Trak

PRT2 1-Trak is a new innovation in guided motion systems which further enhances the acclaimed **PRT2** range of ring and track system products. While conventional track technology limits track paths to simple combinations of straight and curved track segments, **1-Trak** allows any conceivable 2D shape to be realized.

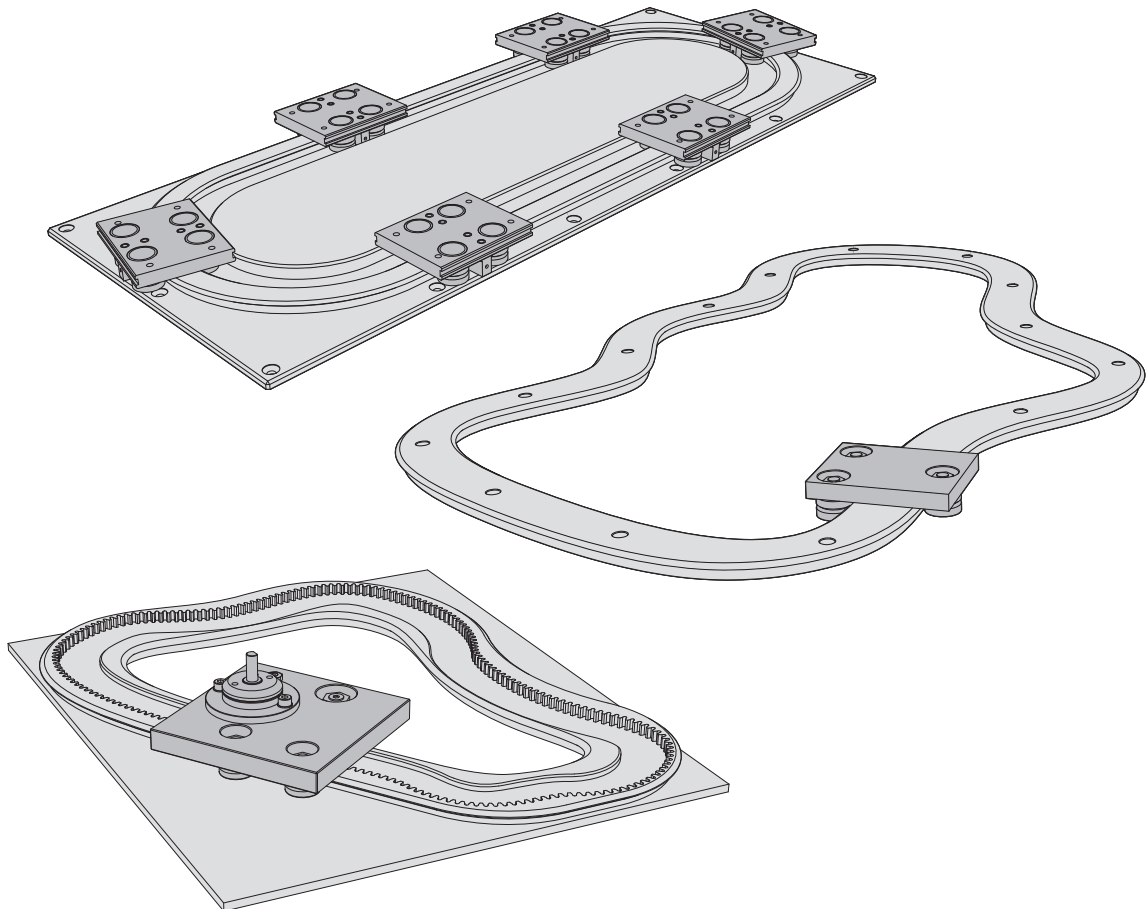

Design Benefits

- Tracks are made in one piece, without joints, and supplied with or without structural base platform
- Tracks with a vee profiled section of any size to suit bearings from Ø13 to 150mm
- Tracks with a rectangular profile and roller carriages, for use in tandem with vee profiled systems to compensate for parallelism tolerances
- Track systems with no play between carriage wheels and the track, anywhere around the circuit
- The option of corrosion resistant tracks, carriages, and bearings

Sold & Serviced By:



Toll Free Phone (877) SERV098

Toll Free Fax (877) SERV099

www.electromate.com

sales@electromate.com

One Piece Tracks With Integral Base Plate

PRT2 1-Trak systems are precision machined in one piece from very high grade steel and are surface hardened for wear resistance. A unique manufacturing approach ensures high accuracy and close tolerances on straightness, flatness, and shape.

This construction eliminates assembly due to the absence of joints, with no possibility of misalignment during installation or in service.

1-Trak is made from a single piece of steel so that the track is one with the base plate. This gives a very strong and accurate foundation which can be the key structural element of a machine. It can be made to a customer's design with holes, slots, and other features, and can be supplied mounted to a Bishop-Wisecarver Corporation® MCS frame, as shown below.

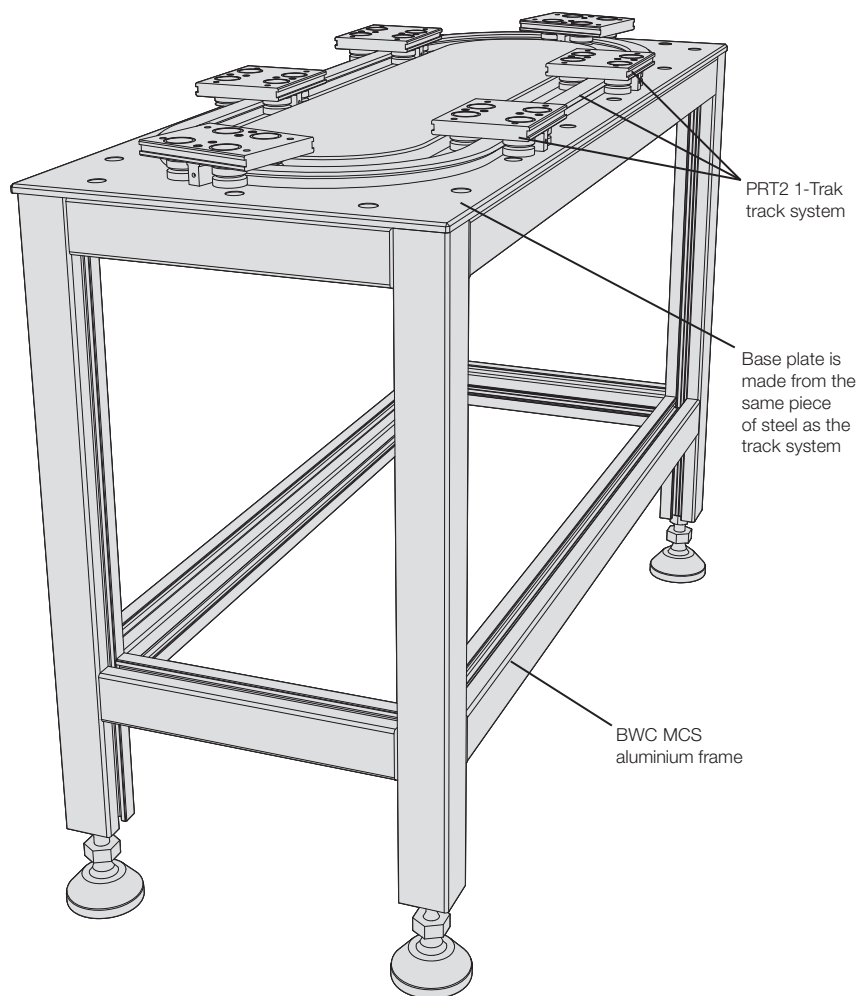

1-Trak construction provides the flexibility to choose curves of any radius, and tracks of any width. Overall system size is limited to within a 5.5m x 1m rectangle or a 1.9m square. Larger track systems can be made up of individual elements.

Sold & Serviced By:



Toll Free Phone (877) SERV098

Toll Free Fax (877) SERV099

www.electromate.com

sales@electromate.com

Three Bearing Carriage Geometry

A key innovation of the **PRT2 1-Trak** design is the three bearing carriage. This offers great flexibility, but at the expense of reduced load capacity compared to a four bearing carriage. The reduction depends on the load configuration, but 25% is typical.

In a conventional **PRT2** track system, the width of straight and curved sections in one track is always the same. When fixed center (FCC type) carriages are used, a small amount of play is experienced at the straight-to-curve transitions, though not elsewhere.

In a **1-Trak** three bearing system, the track width constantly changes depending on the bend radius, to eliminate play. In the track system below, the widths of the track at positions A, B, C, and D are all different, and the carriage travels with all three wheels in uniform contact all of the way around the circuit.

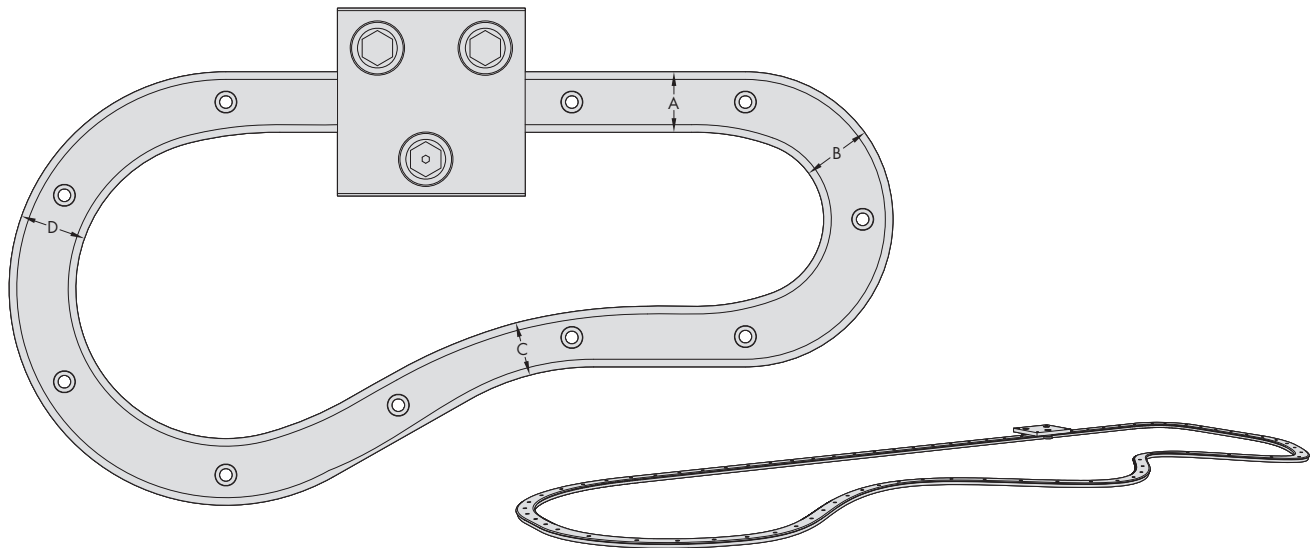

The concept is very simple, but its design and manufacture require innovative and sophisticated methods which are newly developed by Bishop-Wisecarver Corporation® and patent pending.

The use of three bearing carriage geometry provides many advantages:

- Carriages have zero play at all positions on the track
- A track system can follow almost any two dimensional path, including straight sections, curves of differing radii, reverse bends, and free-form curves
- Track systems can have much tighter bends than is possible with other designs, saving space and cost
- For tracks with both left and right hand bends in lower load situations, three bearing carriages are a simple low cost alternative to bogie carriages
- Tracks can be made in a wide section to give higher moment load capability

Sold & Serviced By:



Toll Free Phone (877) SERV098

Toll Free Fax (877) SERV099

www.electromate.com

sales@electromate.com

Track Systems With Complete Size Flexibility

Standard **PRT2** track system components are produced in volume and are the popular choice for most rectangular and oval circuits, where the straight and curved slides can use standard radii and section widths. The **1-Trak** approach, however, provides complete flexibility to chosen dimensions to meet exactly the requirements of the application. Generally, **1-Trak** systems are more expensive than similar standard **PRT2** tracks, but smaller systems made in volume may cost less.

With the **1-Trak** system, it is possible to have very wide slide sections with bearings which are widely spaced both across and along the carriage. This will provide a very rigid platform and increase moment load capacity. Such carriage design can negotiate curves with a much smaller bend radius than is possible using conventional designs. Reduced bend radii allow machines to be made smaller, which saves space, cost and can improve speed of operation.

Carriages with all three bearings of the same size have an asymmetric load capacity. In such cases, the single bearing of the three bearing format, which is usually on the inside of the circuit, will be the life-determining factor. By specifying a larger size single bearing, it is possible to achieve a more equal load capacity across the carriage and more load capacity overall.

The example system shown below has widely spaced bearings, a tight bend radius, uses a larger bearing on the inside of the track, and also has an integral base plate. It therefore uses many of the positive features of the **PRT2 1-Trak** approach.

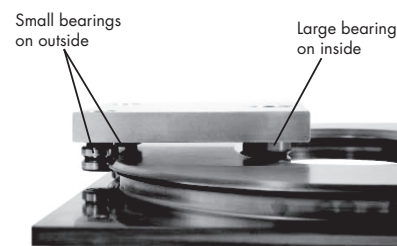
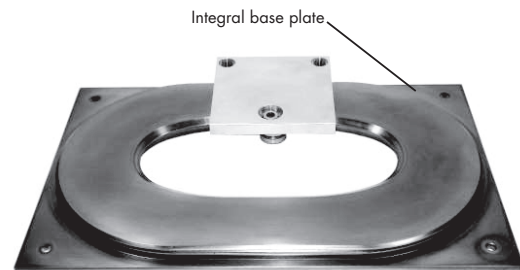

A further useful version of **PRT2 1-Trak** is shown below. In this design, the carriage fits inside a channel-section track which has inward-facing vees that engage the bearings. The advantage of this configuration is that the contact points between bearings and slide vees are spaced very far apart, giving higher moment load capacity and stiffness.

PRT2 1-Trak systems can be made in a huge range of sizes, using bearings from Ø13 through 18; 25, 34, 54, 64, 95, 120; 128 to 150mm. These bearings are taken from the **PRT2** and HDS2 ranges.

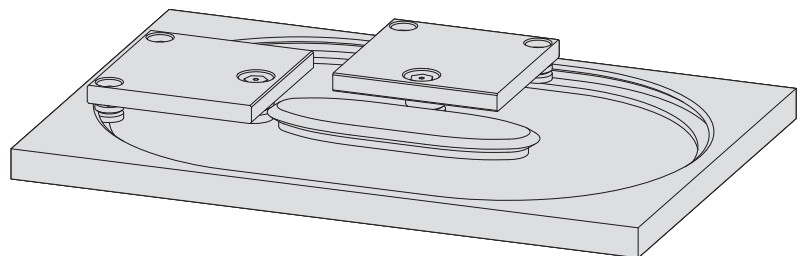

Sold & Serviced By:



Toll Free Phone (877) SERV098

Toll Free Fax (877) SERV099

www.electromate.com

sales@electromate.com

Track Systems With Rack and Pinion Drive

PRT2 1-Trak is also available with a rack and pinion driven carriage.

Uniquely, the **1-Trak** design allows correct and constant mesh between pinion and rack all around the circuit. Unlike other systems, the pitch line of the rack follows a complex path in unison with that of the pinion. Therefore, there is no requirement to have the pinion sprung against the rack to compensate for varying engagement. This hugely simplifies the carriage design, and increases load capacity.

The gear teeth on the track are precision machined and surface hardened to produce outstanding strength and durability. When used with a hardened pinion and properly lubricated, high driving forces, minimal backlash, and long life will be achieved. MOD1.5 gear teeth up to 6mm wide are possible for smaller systems.

For larger gears, MOD2 teeth up to 8mm, MOD3 teeth up to 12mm, MOD5 teeth up to 20mm, MOD8 teeth up to 33mm, and MOD10 teeth up to 40mm wide are recommended.

Bishop-Wisecarver Corporation® can supply the pinions alone, carriages complete with pinion and drive flange, or with the pinions mounted onto a gearbox or geared motor. Guidance on gear and pinion specification, and information on load capacity and life expectancy are available from an Applications Engineer.

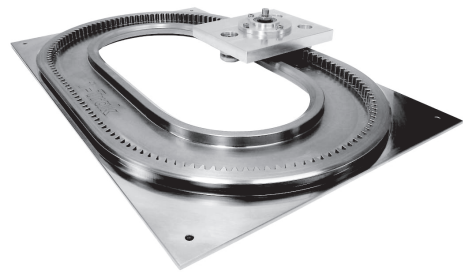

Gear pitch line follows a complex curve to eliminate play.

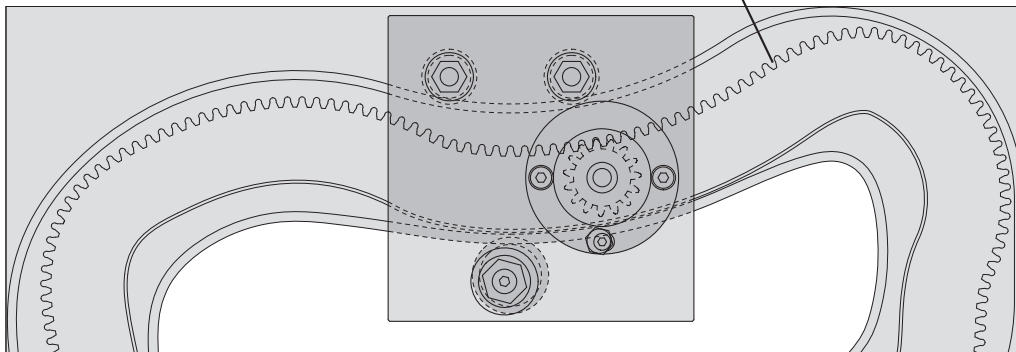

Sold & Serviced By:



Toll Free Phone (877) SERV098

Toll Free Fax (877) SERV099

www.electromate.com

sales@electromate.com

Track Systems Used in Parallel

When vee profiled track systems are mounted in parallel onto a rigid support, any installation parallelism errors can result in the preloading of the system. This may cause binding, excessive loading of bearings, and increased friction.

To address this issue, **PRT2 1-Trak** systems can be made with a rectangular profile using carriages with Bishop-Wisecarver Corporation® GV3 track rollers. This design provides precise, play-free guidance for movement around the track, but allows freedom for the carriages to move in the direction of the roller axes (see example below).

This type of track system is shown in parallel with a vee profiled track, in the arrangement below. The rectangular section track system ensures that no preloading stresses are created. This will improve the running quality, friction, life, and ease-of-installation of such systems.

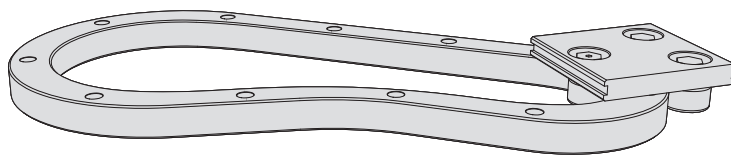

The methods of manufacture, materials, and size capability are the same for rectangular track systems as they are for vee profiled ones. They should be specified as a set, with the rectangular and vee profiled tracks being made to match. In these sets, the diameters of the rollers and vee bearings will typically be the same.

In this type of system, it can be beneficial to have a gear drive on both track systems, with the driving pinions connected together either using a common drive shaft, or with separate servo drives and linked controls. This approach can eliminate the distortion which can occur if drive comes from one side only.

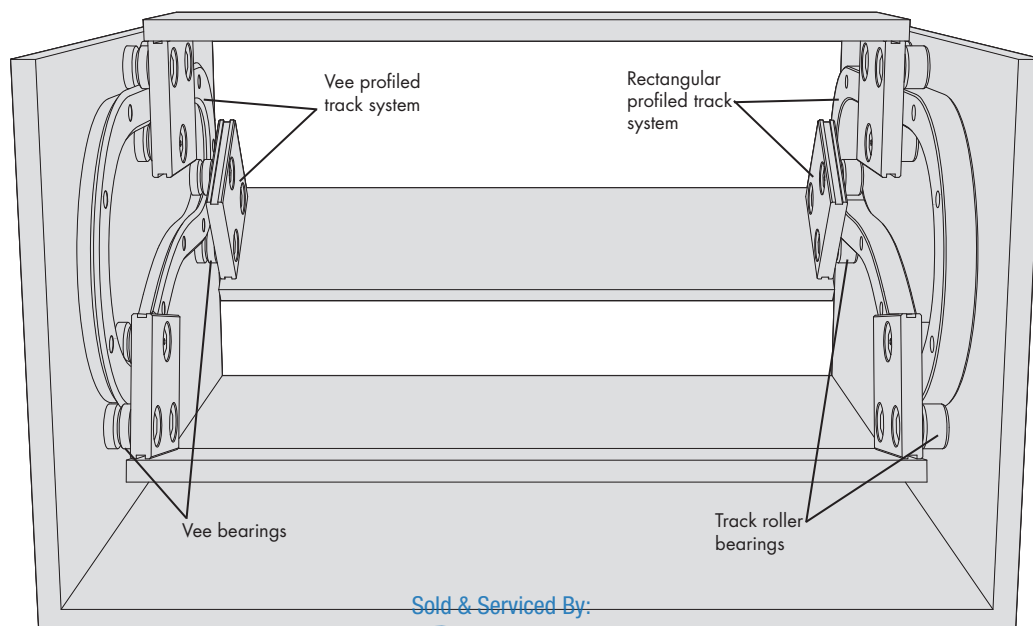

Sold & Serviced By:



Toll Free Phone (877) SERV098

Toll Free Fax (877) SERV099

www.electromate.com

sales@electromate.com

Specify a PRT2 1-Trak System

The following is a guide on how to specify a **PRT2 1-Trak** system when working with an Applications Engineer.

- **Specify the carriage:** For bearing sizes, part numbers, and capacities see the table on page 8. For other information see the **PRT2** catalog or speak with an Applications Engineer directly.
- **Pair of concentric (non adjustable) bearings:** Specify the part number and whether the bearings face inside or outside the circuit.
- **Single eccentric (adjustable) bearing:** Consider whether this should be the same size as the pair of concentric bearings, for asymmetrical load bearing, or a larger size to achieve symmetrical load bearing capability.
- **Specify the part number**
- **Bearing positions:** Specify dimensions X, Y (see drawing).
- **Carriage dimensions:** Specify dimensions L, W, T, H (see drawing).
- **Specify the number of carriages on the circuit**
- **Specify the track:** The carriage information specified above will automatically define the track section.
- **Specify the track shape:** The shape is defined by the path at the center of the pair of bearings as shown in the drawing above. This is best conveyed using a sketch showing the relevant dimensions (e.g., straight length S, and radius R). The pair of bearings can follow (subject to limits imposed by the bearing diameter) any 2D path including ellipses, spirals, parabolas, and B-splines. For track designs which include such shapes, a CAD file of the required path should be provided. It is also possible to produce a track system where another point on the carriage follows the defined path. In these cases, the position of that point should be advised along with details of the path required.
- **Specify integral base and customization requirements:** Please provide a sketch showing details and dimensions of all holes, slots, cut outs, and special carriage shape requirements. Also, please provide details of the integral base if required, including overall dimensions within the size limitations stated on page 2. To minimize cost, customers are encouraged to specify systems where the overall thickness is at or below one of the following sizes: 9, 12.5, 18, 25, and 36mm. Other sizes are possible up to 100mm thick.

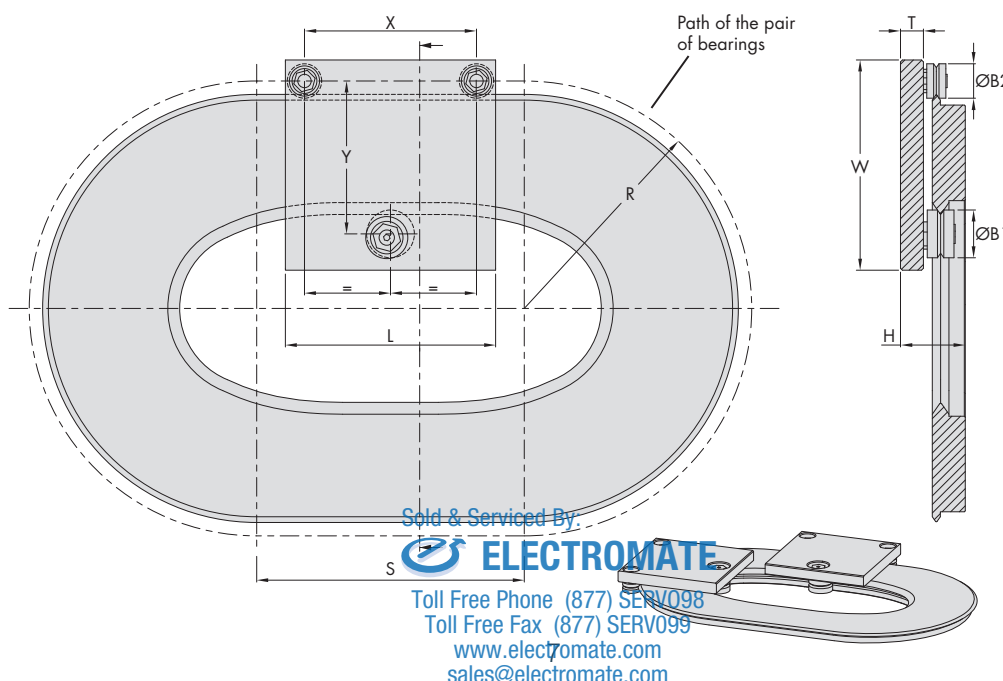

Specify a PRT2 1-Trak System

- Lubrication Options:** An oil film on the running surfaces of the vees is essential to the **1-Trak** system in order to reduce wear and prolong life. This can be achieved by the following methods and should be discussed first with an Applications Engineer.
- Lubricators:** In many cases, **PRT2** Lubricators can be fitted to the carriage (see **PRT2** catalogue page 37). However, this is only possible in systems without tight bends, due to limited stroke of the wipers.
- Bleed Lubrication:** This system channels lubricant directly to the vees of the track and can be incorporated into most **1-Trak** systems.
- Gear Driven Option:** The gears on a **1-Trak** system have enhanced load capacity due to surface hardness. This increases life and delivers superior performance. Bishop-Wisecarver Corporation® will provide calculations of load capacity and life for specific applications. To define the gear, it is only necessary to specify the pinion size required, its position on the carriage, the face width of the gear (see page 5), and whether the gear is facing inwards or outwards. Note that the pinion may be positioned away from the center of the carriage. A range of hardened pinions can be found in the HDS2 catalogue (see page 35). Bishop-Wisecarver Corporation® has a range of geared motors, gearboxes, and drive flanges available to cater to most drive requirements. Please see the GV3 and HDS2 catalogs.

Materials and Finishes

Standard **PRT2 1-Trak** systems are made from high grade steel and have a precision machined finish. A corrosion resistant finish is available for the tracks. The vee bearings and track rollers are all available in standard and stainless steel variants. Carriage plates can be manufactured in any convenient engineering material, but the default choice is high strength aluminium with a clear anodized finish. An enhanced corrosion resistant treatment is available if required.

Load and Life

The load capacity and life of **1-Trak** systems with rectangular profiled tracks are determined by the track rollers which run on them. The performance of these rollers is detailed in the GV3 catalog (see page 60).

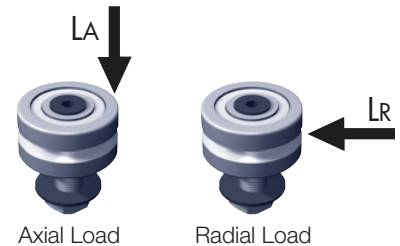

For further information and assistance, please contact Bishop-Wisecarver Corporation®. The working load capacity system life is calculated following the approach detailed on pages 2 and 3 of the **PRT2** datasheet (please visit

).

BEARING PART NUMBER	LOAD CAPACITIES FOR DOUBLE ROW BEARINGS (N)			LOAD CAPACITIES FOR TWIN STANDARD BEARINGS (N)		
	LUBRICATED			LUBRICATED		
	LA (MAX) N	LR (MAX) N	BASIC LIFE (KM)	LA (MAX) N	LR (MAX) N	BASIC LIFE (KM)
...J13...	-	-	-	60	120	50
...J18...	190	600	100	125	200	100
...J25...	400	1,500	70	320	600	50
...J34...	900	3,000	250	800	1,400	100
...J54...	2,500	5,000	500	1,800	3,200	250
...J64...	2,500	8,000	500	-	-	-
...J95...	7,000	20,000	400	-	-	-
...J120...	10,000	30,000	400	-	-	-
...J128...	10,000	30,000	400	-	-	-
...J150...	17,000	50,000	400	-	-	-

Sold & Serviced By:

 Toll Free Phone (877) SERV098 -
 Toll Free Fax (877) SERV099
 www.electromate.com
 sales@electromate.com

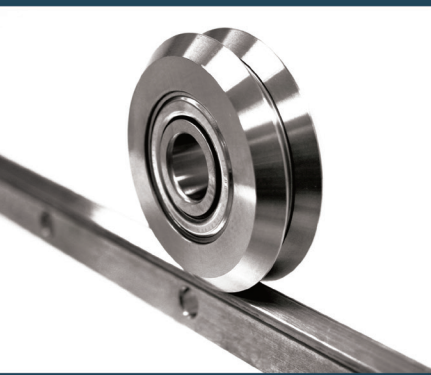

Bishop-Wisecarver Corporation is a WBENC certified woman-owned manufacturer of the original **DualVee®** guide wheel and industry leader in linear and curvilinear motion solutions. Exclusive North and Central American partner and distributor for **HepcoMotion®** products since 1984.

- DualVee®** Guide Wheels
- LoPro®** Linear Motion System
- MadeWell®** Crown Rollers
- MadeWell®** Radial Wheels
- MinVee®** Linear Slide System
- UtiliTrak®** Linear Motion Guide
- UTCSK** Camera Slider Kit
- QuickTrak®** Modular Linear Guide Kit

- HepcoMotion®**
- ALR Aluminum Rings
 - DAPDU2 Double Acting Profile Driven Unit
 - DLS Driven Linear System
 - DTS2 Driven Track System
 - GV3 Linear Guidance and Transmission System
 - HDCB Heavy Duty Compact Beam
 - HDCS Heavy Duty Compact Screw
 - HDLS Heavy Duty Driven Linear System
 - HDRT Heavy Duty Ring Slides and Track System
 - HDS2 Heavy Duty Slide System
 - MHD Heavy Duty Track Roller Guidance System
 - MCS Machine Construction System
 - PDU2 Profile Driven Unit
 - PDU2M Belt Driven Unit
 - PRT2 Precision Ring and Track System
 - PSD80 Screw Driven Linear Actuator
 - PSD120 Profile Screw Driven Unit
 - SBD Sealed Belt Drive
 - Simple-Select®
 - SL2 Stainless Steel Based Slide System

3D CAD DRAWINGS

FOLLOW BISHOP-WISECARVER NEWS & UPDATES

PRODUCT ORDERS

WHAT MAKES US DIFFERENT

Our engineering and manufacturing facility provides expert development support and quick turnaround time. We tackle all engineering challenges with a novel approach — we have the patents to prove it and are majority sourced USA. We offer custom engineering services and technical expertise in motion, sensor and actuator integration, real-time software development, and electromechanical modeling and design.

INDUSTRIES SERVED

- Aerospace & Defense
- Aircraft & Automotive
- Architecture
- Consumer Products
- Conveying Equipment
- Electronics
- Entertainment
- Fabrication
- General Automation
- Industrial Equipment
- Instrumentation
- Lab Automation
- Liquid Handling
- Machine Tool
- Material Handling & Packaging
- Medical Device Manufacturing
- Powertransmission & Railway
- Printing Machinery
- Printed Circuit Assembly
- Research & Development
- Relay & Industrial Controls
- Radio & TV Broadcasting
- Robotics, Semi-Conductor
- Food & Beverage
- Surgical Equipment
- Transportation
- Welding & Soldering
- Wood Processing

Sold & Served By:



Toll Free Phone (877) SERV098

Toll Free Fax (877) SERV099

www.electromate.com

sales@electromate.com