

SL2

Stainless Steel
Based Slide System

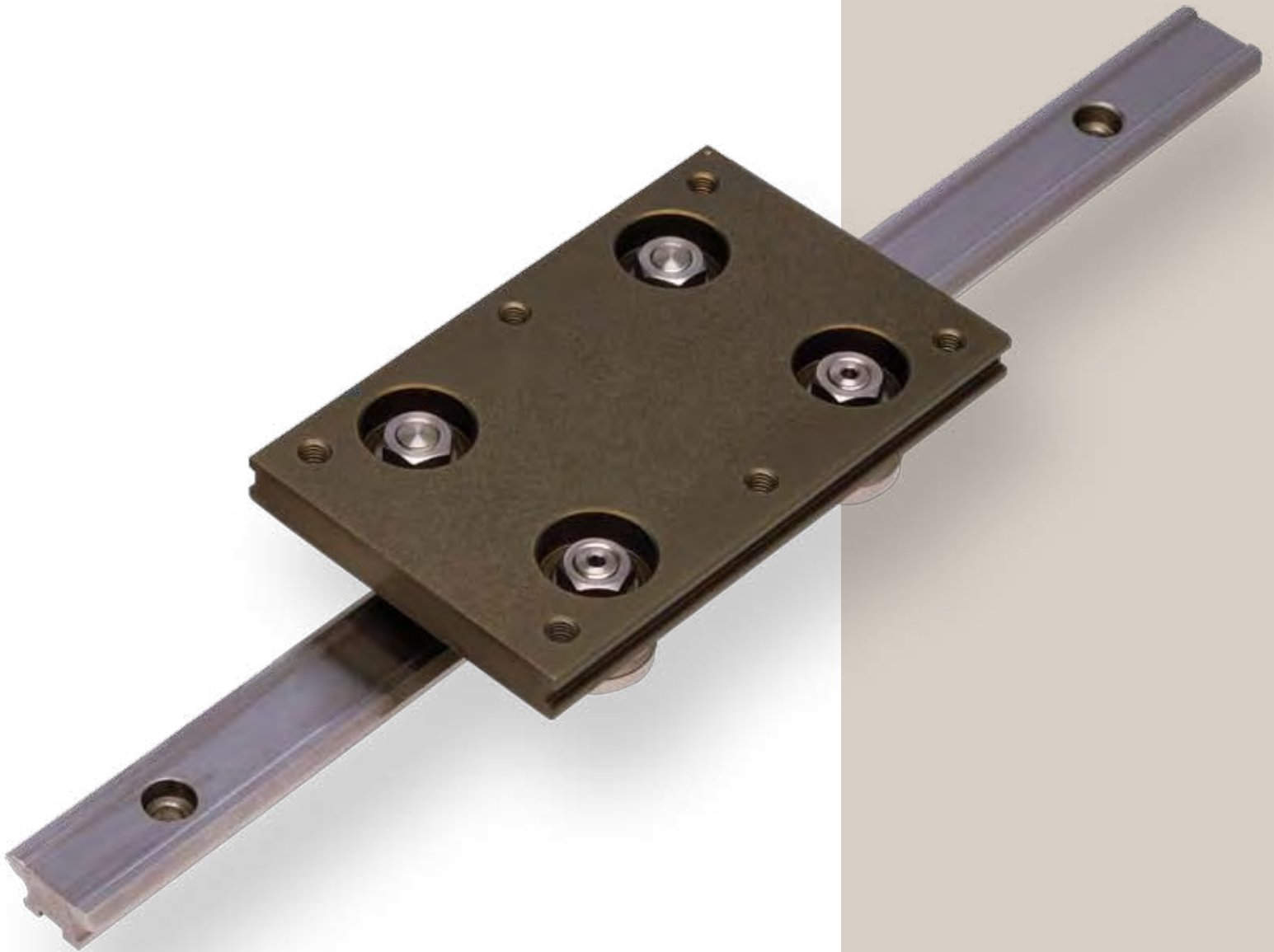

Sold & Serviced By:

 **ELECTROMATE**

Toll Free Phone (877) SERV098

Toll Free Fax (877) SERV099

www.electromate.com

sales@electromate.com

BISHOPWISECARVER®

SL2-Stainless Steel Based Slide System

The HepcoMotion® SL2 system from Bishop-Wisecarver offers the user basic interchangeability with GV3 components¹ consisting of stainless steel bearing assemblies, flat slides and spacer slides.

A complementary range of light-weight aluminum carriage plates and flange clamps is also available, with special surface treatment providing corrosion resistance better than most stainless steels. This process is approved by the U.S. Department of Agriculture for use in food processing machinery.

A variety of applications, including food processing and scientific equipment, have benefited from using SL2: a result of the combination of smooth, precise, low friction movement, and long service life with added corrosion resistance. The SL2 Stainless Steel Based Slide System ensures added durability in the most demanding of operating conditions.



SL2 Benefits

- Hardened and ground slides for durability, corrosion resistance, and smooth running
- Long lengths available up to 4m in most sections minimizes assembly time
- Extensive range of spacer or flat slides provides many design options
- Proven 'V' concept for low friction and good rigidity
- Cap seals prevent ingress of dirt and offer positive lubrication, long life, and improved safety
- Lubricators offer positive lubrication with improved life and low friction
- Suitable for many clean room applications
- Three lengths of carriage plates are available for each slide section, gives many design options
- Double row bearing assembly option for high radial loads and long life, ideal for dirty applications
- Twin bearing assembly option provides low friction and is tolerant of misalignment
- Low friction characteristics allow system to operate 'dry' with no lubrication
- Available as assembled unit or in component form for maximum flexibility
- Extensive use of plastic plugs eliminates dirt traps
- Maintenance-free – can perform in arduous conditions

Notes

1. Also compatible with Generation II.

Sold & Serviced By:



Toll Free Phone (877) SERV098

Toll Free Fax (877) SERV099

www.electromate.com

sales@electromate.com

About Bishop-Wisecarver Corporation®

Bishop-Wisecarver, a family owned manufacturing company incorporated in 1950, is the recognized market leader for guided motion technologies. In 1967, Bud Wisecarver invented and patented DualVee Motion Technology® (DMT) to provide a solution for harsh environment applications where existing technologies were ineffective. DualVee® also proved excellent for long length, smooth motion and low noise requirements. Three main components define DMT – the DualVee guide wheel, its mating vee profile track with patented mounting shoulder, and support bushings.

Available for linear, rotary, or curved track applications, Bishop-Wisecarver’s wide range of linear motion components and systems provide time proven, economical solutions to every industry. These include medical, pharmaceutical, packaging, food processing, machine tools, instrumentation, and semiconductor manufacturing. Guided motion solutions from Bishop-Wisecarver are limited only by your imagination.

System Composition 2 – 3

Application Examples

- Stainless Steel Bearing Assemblies 4
- Aluminum Carriage Plates 5

Data & Dimensions

- Assembled Systems 6 – 9
- Stainless Steel Spacer and Flat Slides 10 – 11
- Stainless Steel Bearing Assemblies 12 – 13
- Aluminum Carriage Plates 14 – 15
- Cap Seals and Lubricators 16
- Flange Clamps 17

Technical Data

- Life/Load Calculations 18
- Life/Load Calculation Examples 19
- Deflection of Self-Supporting Slides 20
- Technical Specifications 21

Installation

- System Assembly and Adjustment 22 – 23

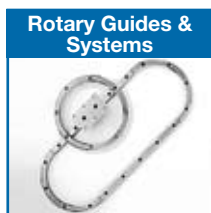

Application and Design Assistance

925.439.8272

3D Modeling and CAD Drawings

Sold & Serviced By: **ELECTROMATE** /3dcad.php

Toll Free Phone (877) SERV098
Toll Free Fax (877) SERV099

System Composition

SL2 offers excellent performance through a quality manufacturing process and careful selection of materials, and has been designed to provide the ideal combination of corrosion resistance and long service life even in the most arduous application.

The SL2 range of slides is very extensive, comprising seven flat slide sections and four spacer slide sections. This very wide range ensures that the most suitable slide can always be specified for any application. All except the smallest are available in 4 meter lengths, ground on all main surfaces with hardened 'V' running faces.

SL2 carriages are available in three standard lengths as fully assembled units, factory adjusted to the slide of your choice. The system makes extensive use of plastic sealing plugs to close off counterbores, thus avoiding the possibility of dirt traps. SL2 is therefore ideally suited for food processing and clean room applications.

Blind Hole Fixing Bearing Assembly Concentric ■ & Eccentric ❑

- ❑ For use where access to opposite side of the mounting plate is restricted
- ❑ Easy fixing from one side only
- ❑ Twin type or double row bearing assemblies available (see opposite)
- ❑ Low ratio adjustment for controlled setting
- Defines the datum position for the system

Stainless Steel Slide Spacer Type ■ & Flat Type ❑

- ❑ Hardened 'V' faces for long life
- ❑ Center section unhardened for drilling or machining
- ❑ Length cut to your requirements, up to 4m in one piece
- Mounts directly to machine. No special construction or additional components required
- Keyway and datum faces for easy alignment
- Available without holes for use with flange clamps or for customizing
- Plastic caps for fixing screws to seal off counterbores
- ❑ Useful where weight saving and minimum inertia are important
- ❑ Extra slide width options

Through Hole Fixing Bearing Assembly Concentric ■ & Eccentric ❑

- ❑ For use in mounting plates of limited thickness where there is unrestricted access to the opposite side
- ❑ Two stud lengths available to suit most mounting plate thicknesses
- ❑ Twin or double row types available (see opposite)
- Defines the datum position for the system
- ❑ Easily adjusted via hexagon flange or socket in stud

Flange Clamps

- Enables slide to become a self-supporting beam
- Two mounting possibilities - face fixing or base fixing
- Available in long or short type, to support a slide at one end or both ends

Sold & Serviced By:

 **ELECTROMATE**

Toll Free Phone (877) SERV098

Toll Free Fax (877) SERV099

www.electromate.com

sales@electromate.com

High strength aluminum, with corrosion resistant coating approved by U.S. Dept. of Agriculture

Carriages can be supplied fitted with:

- Bearing Assemblies only** - for dry or minimum friction applications
- Cap Seals** - to shroud the bearing assemblies - for excellent lubrication and sealing quality
- Lubricators** - for the application of lubricant with lower friction

All components are available individually for customers who wish to construct their own carriage plates, or where the carriage may be part of the machine structure. All bearing assemblies are of stainless steel construction, in either twin bearing or double row format, and are supplied lubricated for life. They are hardened and precision ground to special tolerances and raceway conformity to suit slide system applications.

Stainless Steel Twin or Double Row Bearing Option Across Range*

- Twin type bearing assemblies provide slight compliance offering accurate, play-free motion and tolerance of misalignment. Frictional resistance can be varied, useful where very low friction is required. Economical, and easy to adjust.
- Double row bearing assemblies have higher radial load capacity. They are more suited to harsh environments and high speed conditions where extra long life is required. One piece construction avoids dirt traps.

*All except smallest size

Lubricator (Optional)

- Use with short carriage plate/miniature system or as an option to cap seals on longer carriage plates
- Provides lower friction running with long system life
- Applies very small quantities of oil, for long system life
- Supplied charged with mineral oil as standard, or dry on request (for other oil types)

Cap Seal (Optional)

- Lubricates contact surfaces from a grease reservoir, giving extended re-lubrication interval and long system life
- Totally encloses the bearing assembly
- Increases load capacity
- Extends system life
- Excludes debris
- Improves operational safety
- Can be used on medium and long carriage lengths (on all but miniature systems)

Carriage Plate

- High strength, lightweight aluminum alloy with corrosion resistant coating approved by the U.S. Dept. of Agriculture
- Large mounting area with flush surface
- Three standard lengths in each size
- Pre-drilled & tapped component mounting holes
- Counterbores sealed with plastic plugs to eliminate dirt traps
- Recess both sides to facilitate location of switch cams and other components

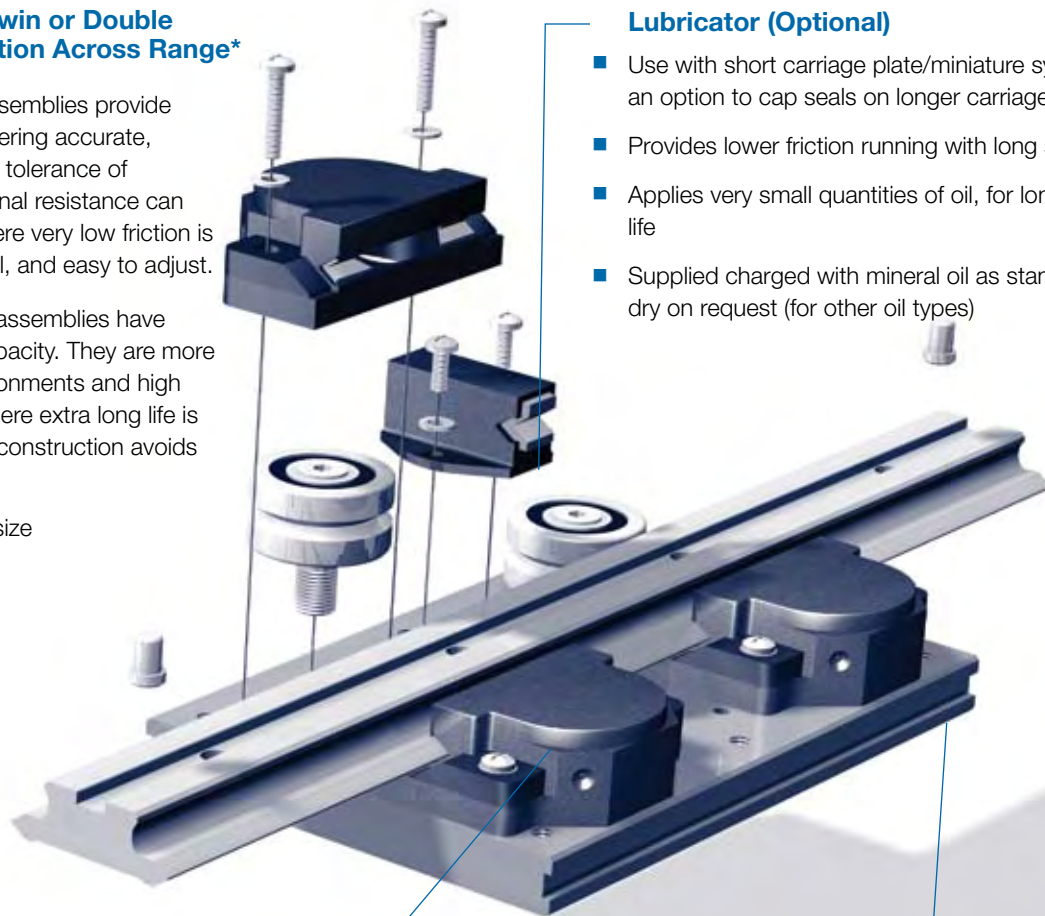

Sold & Serviced By:



Toll Free Phone (877) SERV098
Toll Free Fax (877) SERV099

© Bishop-Wisecarver Corporation, 2008. All rights reserved.
sales@electromate.com

Stainless steel carriage plates available on request (to customer's drawings)

Application Examples

Industrial Applications

SL2 system is used for vertical and horizontal guidance on a bottle filling machine in the cosmetics industry.

Spacer slides are shown fixed to the machine structure on the horizontal axis. Short undrilled spacer slides are used on the vertical axis supported one end only by long type flange clamps. Carriage plates are shown used throughout. Alternatively, bearing assemblies and cap seals can be mounted direct to the moving components of the machine. Care should be taken to ensure parallelism of opposing slides during installation. Twin type bearing assemblies can be used throughout in cases where there may be slight misalignment of opposing slides.

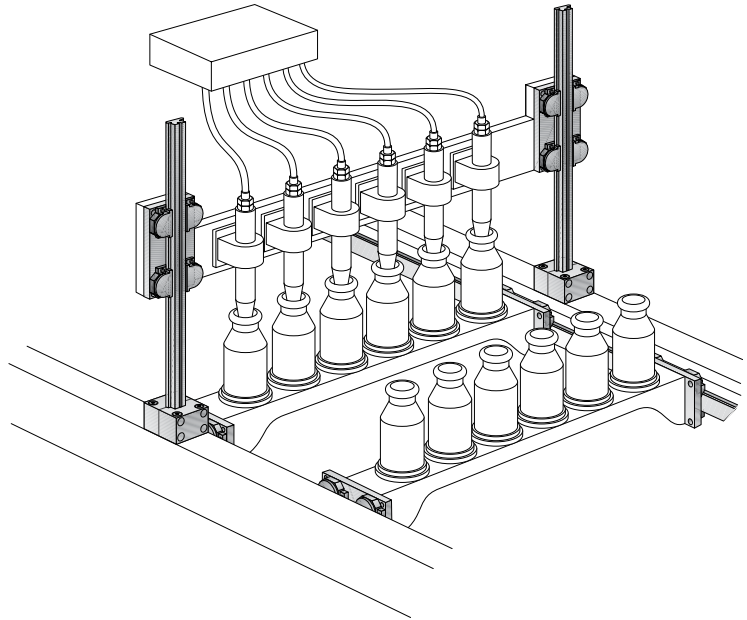

SL2 system is used as the vertical guidance in a food industry application to move a diverting conveyor alternately. High speed and high duty operation driven by a crank arm.

The SL2 flat slide has been chosen as the moving element in order to reduce mass. Blind hole type bearing assemblies have been used due to the thickness of the mounting plate being too great to accommodate the stud and nut of the through fixing type.

The system is lubricated by means of lubricators, since cap seals cannot be used with the blind hole eccentric type bearing assemblies. Lubricated systems allow much greater life for any given load (see Load/Life section).

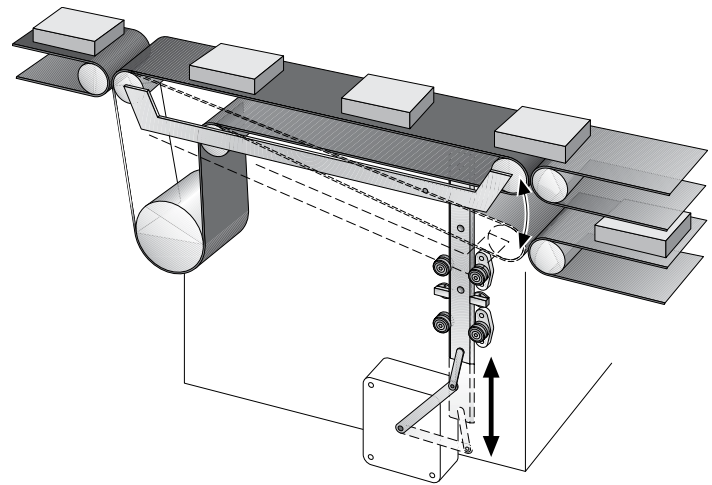

Scientific/Test Applications

SL2 system is used for telescopic horizontal guidance in a nuclear industry drum handling application. Vertical movement is provided by a scissor lift.

The environment experiences a low level of radiation. Therefore the bearing assemblies are supplied with special grease lubrication internally. Because the system is required to be all stainless steel, the standard coated aluminum carriage plates have been replaced by specials, manufactured to the customer's drawings. External lubrication of the slides is not possible in this application. However, the low friction characteristics of SL2 systems means that 'dry' running is not a problem.

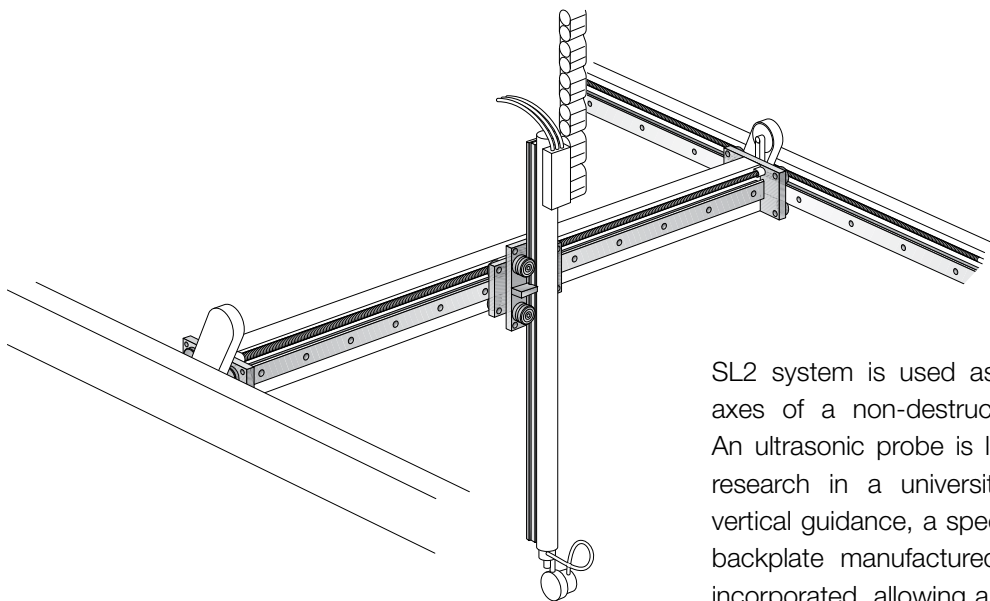
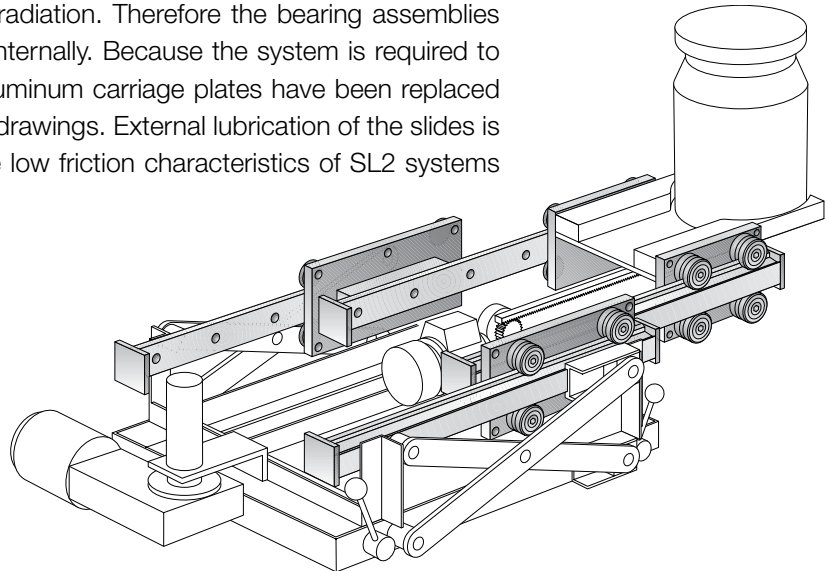

SL2 system is used as the means of guidance for all axes of a non-destructive ultrasonic testing machine. An ultrasonic probe is lowered into a spray tank during research in a university engineering department. For vertical guidance, a special curved section stainless steel backplate manufactured to the customer's drawing is incorporated, allowing an SL2 flat slide to be mounted to the circular section probe. The SL2 system is ideally suited to this humid environment.

The use of twin type bearing assemblies offers extra compliance to compensate for slight deviations of the opposing slides on the horizontal axis. Lubricators give increased system life while retaining low friction. The zero play which is characteristic of the SL2 system ensures rigidity at the probe end, despite the large overhang in this application.

Sold & Serviced By:



Toll Free Phone (877) SERV098

Toll Free Fax (877) SERV099

www.electromate.com
sales@electromate.com

© Bishop-Wisecarver Corporation 2008. All rights reserved.

Data & Dimensions

Assembled Systems

SL2 can be ordered as individual components or as a factory assembled system. Ready-assembled carriages are available with just the bearing assemblies fitted, or with the addition of either cap seals or lubricators (see Stock SL2 Carriage table, page 9). The following three pages show important reference dimensions between assembled components, as well as the maximum overall sizes of the assemblies. Other dimensions will be found on the pages relating to the specific components (10 - 17).

Assembled Systems Incorporating Carriage Plates, Through Hole Fixing Bearing Assemblies and Cap Seals

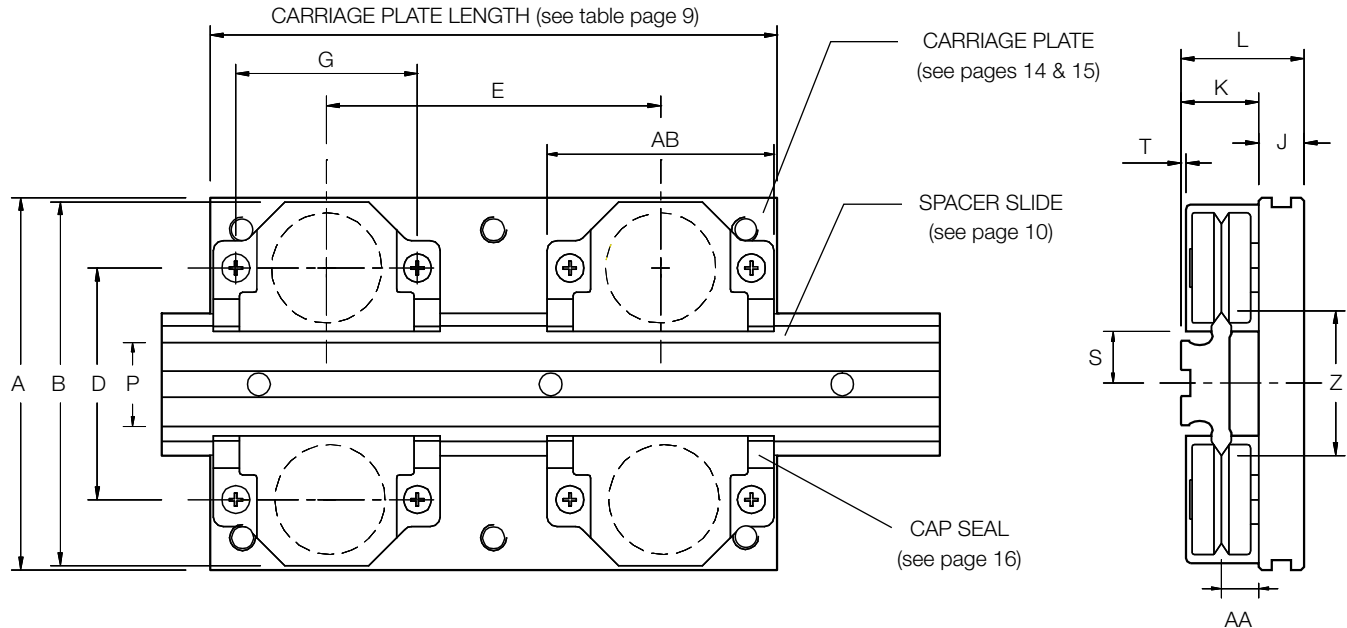

Slide Section (see note 1)	Z Size ~	Bearing Assembly (see note 1)	A	B	C	D (see note 2)	E (see note 3)			F	G	H	I	J
							Min	Min LB	Min CS					
SS MS 12	12	SS S/LJ 13	40	-	36	22.2	14	32	-	34.9	-	12	23	7.4
SS NMS 12	12	SS S/LJ 13	40	-	36	22	14	32	-	34.7	-	12	23	7.4
SS S 25	25	SS S/LJ 25	80	76.4	73	46.3	26	52	56	71.3	45	18	45	11.5
SS NS 25	25	SS S/LJ 25	80	76.8	73	46.1	26	52	56	71.1	45	18	45	11.5
SS S 35	35	SS S/LJ 25	95	86.8	83	56.2	26	52	56	81.2	45	18	55	12.5
SS S 50	50	SS S/LJ 25	112	101.8	98	71.3	26	52	56	96.3	45	18	70	14.0
SS M 44	44	SS S/LJ 34	116	113.1	107	72.1	35	70	71	106.1	56	25	69	14.5
SS NM 44	44	SS S/LJ 34	116	113.1	107	71.9	35	70	71	105.9	56	25	69	14.5
SS M 60	60	SS S/LJ 34	135	129.1	123	88	35	70	71	122	56	25	85	17.0
SS M 76	76	SS S/LJ 34	150	145.1	139	104	35	70	71	138	56	25	101	18.0
SS L 76	76	SS S/LJ 54	185	179.7	171	118.8	55	106	99	172.8	80	38	114	20.0
SS NL 76	76	SS S/LJ 54	185	179.7	171	118.6	55	106	99	172.6	80	38	114	20.0

CONTINUED ON NEXT PAGE

Notes

- Bearing assemblies stated above are the standard size for use with each slide profile. Bearing assemblies and slides can, however, be 'mixed and matched' according to practicality of design. In these cases the following should be noted:
 - Cap seals may only be used with slides which are of the same thickness or thicker than the standard slides quoted in the table.
 - Lubricators may only be used with slides of the same thickness or thinner than the standard slides in the table above.
 - Non-standard combinations will have different assembled dimensions - these can be calculated by referring to the individual components' dimension tables, taking care to use 'theoretical apex' AA dimensions to calculate bearing assembly drilling centers.

Notes are continued on page 7

The dimensions shown in the tables relate to the standard combination of bearing assembly and slide. However, since a common 70° angle is maintained, components may be 'mixed and matched' in most circumstances (see note 1).

**Assembled Systems Incorporating Carriage Plates,
Through Hole Fixing Bearing Assemblies and Lubricators**

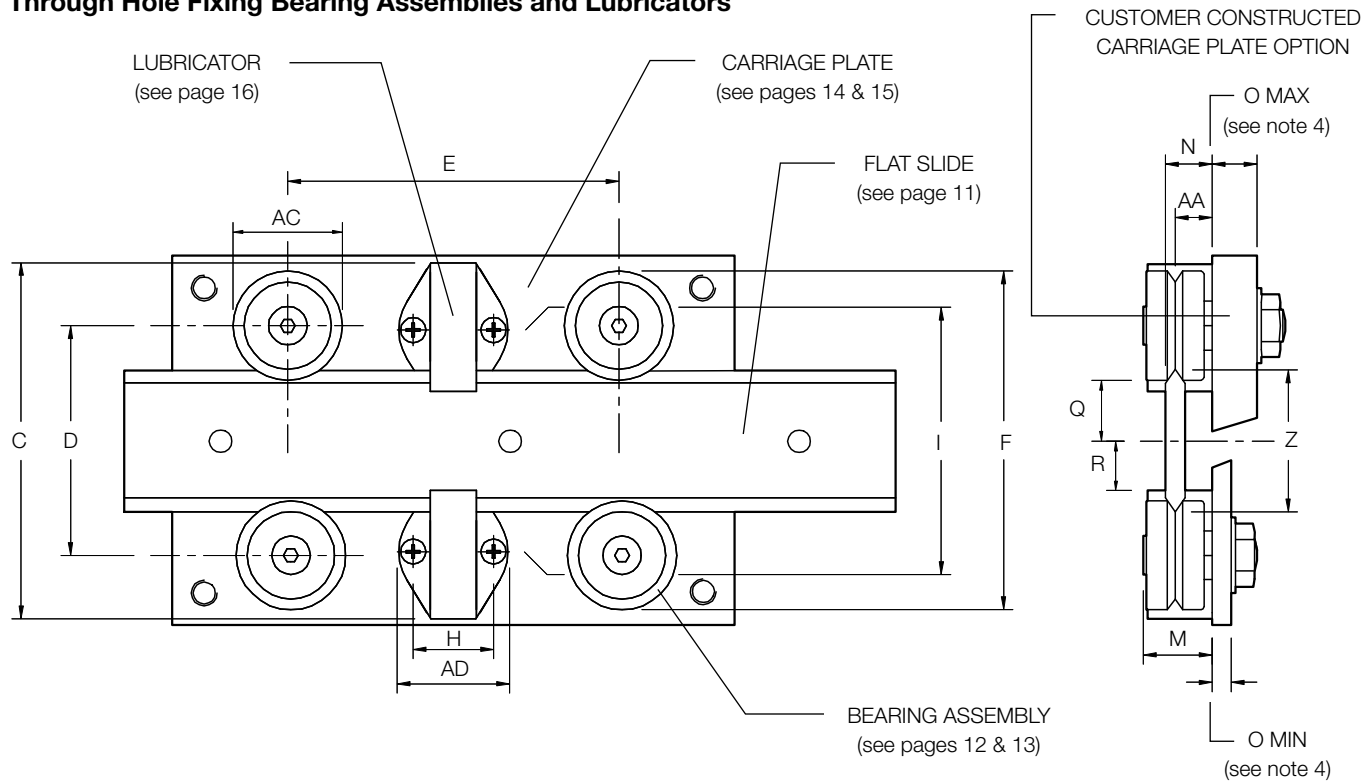

	K ± 0.05	L + 0.13 - 0.05	M	N ± 0.08	O Min (see note 4)	O Max (see note 4)	P	Q	R	S	T	AA ± 0.025	AB	AC	AD	Z Size ~	Slide Section (see note 1)		
CONTINUED FROM PREVIOUS PAGE	-	-	10.1	6.95	2.5	6	-	4.8	5	-	-	5.46	-	12.7	17	12	SS	MS	12
	11.67	19.06	10.1	-	2.5	6	8.5	4.7	5	-	-	5.46	-	12.7	17	12	SS	NMS	12
	-	-	16.6	11.35	2.5	13	-	10.7	8.5	8.4	-	9	55	25	25	25	SS	S	25
	19	30.5	16.6	-	2.5	13	15	10.6	8.5	8.4	1	9	55	25	25	25	SS	NS	25
	-	-	16.6	11.35	2.5	13	-	15.6	13.5	13.4	-	9	55	25	25	35	SS	S	35
	-	-	16.6	11.35	5.5	13	-	23.2	21	20.9	-	9	55	25	25	50	SS	S	50
	-	-	21.3	14.57	5.5	14	-	19	15.5	16.5	-	11.5	70	34	34	44	SS	M	44
	24	38.5	21.3	-	5.5	14	26	19	15.5	16.5	1.5	11.5	70	34	34	44	SS	NM	44
	-	-	21.3	14.57	5.5	14	-	27	23.5	24.5	-	11.5	70	34	34	60	SS	M	60
	-	-	21.3	14.57	5.5	14	-	35	31.5	32.5	-	11.5	70	34	34	76	SS	M	76
	-	-	34.7	23.56	6	20	-	32.4	28.5	29.8	-	19	98	54	50	76	SS	L	76
	38.5	58.5	34.7	-	6	20	50	32.3	28.5	29.8	2	19	98	54	50	76	SS	NL	76

Notes (continued)

- Customers constructing their own carriage plate should drill the bearing assembly hole centers according to 'D' dimension, to a recommended tolerance of ±0.2mm. Holes should be drilled and reamed to size and tolerance per 'R' dimension, page 15.
- Although dimension 'E' is expressed as minimum values, it is recommended wherever possible to have E > D for rigidity purposes. Dimension 'E', Min CS and Min LB refer to the minimum bearing assembly spacing when customers are using Cap Seals (CS) or Lubricators (LB) with their own carriage plates. The equivalent dimension for carriages can be obtained from carriage plate pages 14 & 15.
- Two lengths of stud are available for each size of bearing assembly, choose according to your carriage plate thickness requirement.

Notes are continued on page 8



Toll Free Phone (877) SERV098
Toll Free Fax (877) SERV099

Data & Dimensions

Assembled Systems

Blind hole fixing bearing assemblies are for use where access to the back of the mounting plate is not possible or where the thickness of the mounting plate prevents use of the through hole fixing bearing assemblies. These circumstances are not relevant to the use of carriage plates. Therefore systems using blind hole fixing bearing assemblies are not available factory assembled.

Assembled Systems Incorporating Blind Hole Fixing Bearing Assemblies and Lubricators

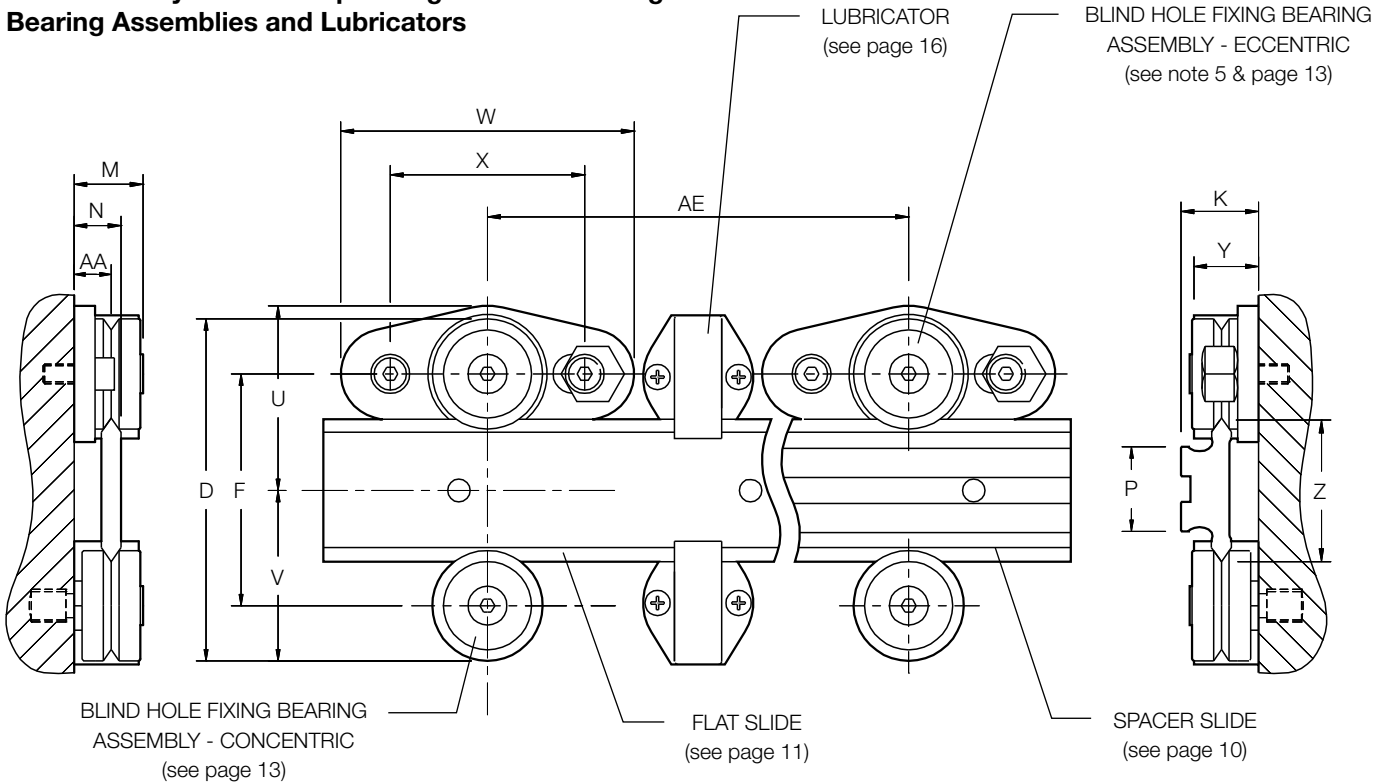

Slide Section (see note 1)	Z Size ~	Bearing Assembly (see note 1)	AA ±0.025	D (see note 2)	AE (see note 6)		F	K ±0.05	M	N ±0.08	P	U	V	W	X	Y
					Min	Min LB										
SS MS 12	12	SS BHJ 13	5.46	22.2	48.5	66.5	34.9	-	10.1	6.95	-	21.1	17.5	47.5	30.0	10.0
SS NMS 12	12	SS BHJ 13	5.46	22	48.5	66.5	34.7	11.67	10.1	-	8.5	21.0	17.4	47.5	30.0	10.0
SS S 25	25	SS BHJ 25	9	46.3	73.0	99.0	71.3	-	16.6	11.35	-	39.2	35.7	72.0	50.0	16.5
SS NS 25	25	SS BHJ 25	9	46.1	73.0	99.0	71.1	19.0	16.6	-	15	39.1	35.6	72.0	50.0	16.5
SS S 35	35	SS BHJ 25	9	56.2	73.0	99.0	81.2	-	16.6	11.35	-	44.1	40.6	72.0	50.0	16.5
SS S 50	50	SS BHJ 25	9	71.3	73.0	99.0	96.3	-	16.6	11.35	-	51.6	48.2	72.0	50.0	16.5
SS M 44	44	SS BHJ 34	11.5	72.1	92.0	128.0	106.1	-	21.3	14.57	-	57.0	53.1	90.5	60.0	20.0
SS NM 44	44	SS BHJ 34	11.5	71.9	92.0	128.0	105.9	24.0	21.3	-	26	57.0	53.0	90.5	60.0	20.0
SS M 60	60	SS BHJ 34	11.5	88	92.0	128.0	122	-	21.3	14.57	-	65.0	61.0	90.5	60.0	20.0
SS M 76	76	SS BHJ 34	11.5	104	92.0	128.0	138	-	21.3	14.57	-	73.0	69.0	90.5	60.0	20.0
SS L 76	76	SS BHJ 54	19	118.8	134.0	185.0	172.8	-	34.7	23.56	-	90.4	86.4	133.0	89.5	33.5
SS NL 76	76	SS BHJ 54	19	118.6	134.0	185.0	172.6	38.5	34.7	-	50	90.3	86.3	133.0	89.5	33.5

CONTINUED FROM PREVIOUS PAGE

Notes (continued)

- Cap seals cannot be used with eccentric blind hole fixing bearing assemblies, as they will not fit over the adjustment mechanism.
- Dimension 'AE', Min LB is the minimum blind hole fixing bearing assembly spacing when using bearing lubricators.

Ordering Assembled Systems

The table below shows the combinations of components available to make up a factory assembled carriage. Pages 10 to 17 detailing individual components will aid the selection of assembled systems, and will explain the relative merits of various component choices, e.g. cap seals versus lubricators, twin versus double row bearing assemblies.

Once the component combination for an assembled system has been decided upon, the table below can be consulted for availability and a part number specified according to the table and the ordering details shown.

Stock SL2 Carriages in Assembled and Adjusted Condition

Part Number	Carriage Length	Available With Cap Seals	Available With Lubricators	Twin Bearing (Standard)	DR Double Row Bearing Option
AU SS MS 12	50	–	✓	✓	–
	75	–	✓	✓	–
	100	–	✓	✓	–
AU SS S 25	80	–	✓	✓	✓
	130	✓	✓	✓	✓
	180	✓	✓	✓	✓
AU SS S 35	100	–	✓	✓	✓
	150	✓	✓	✓	✓
	200	✓	✓	✓	✓
AU SS S 50	110	–	✓	✓	✓
	160	✓	✓	✓	✓
	220	✓	✓	✓	✓
AU SS M 44	125	–	✓	✓	✓
	175	✓	✓	✓	✓
	225	✓	✓	✓	✓
AU SS M 60	150	–	✓	✓	✓
	200	✓	✓	✓	✓
	280	✓	✓	✓	✓
AU SS M 76	170	–	✓	✓	✓
	240	✓	✓	✓	✓
	340	✓	✓	✓	✓
AU SS L 76	200	–	✓	✓	✓
	300	✓	✓	✓	✓
	400	✓	✓	✓	✓

Ordering Details

AUSSM44 225 (CS) (LB) (DR) + SSNM44 626

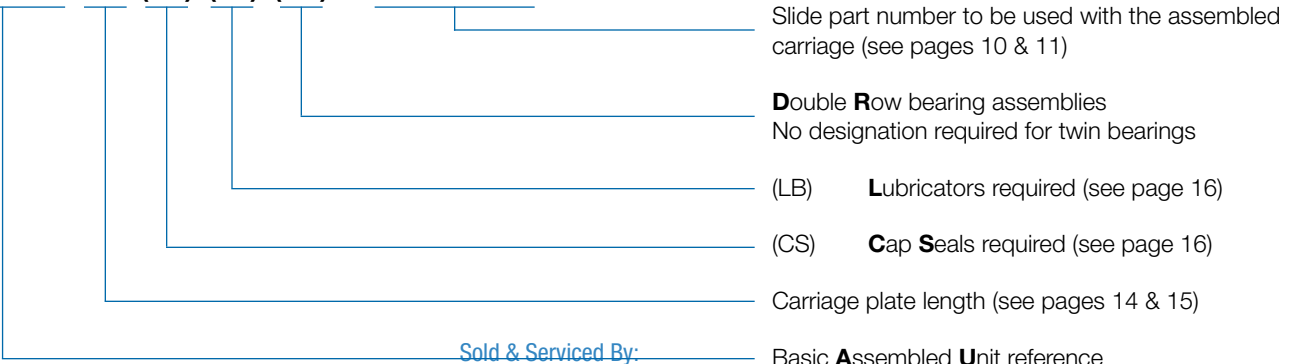

Toll Free Phone (877) SERV098
Toll Free Fax (877) SERV099

Data & Dimensions

Stainless Steel Spacer and Flat Slides

SL2 stainless steel slides are zone hardened on the 'V' edges and precision ground on all main surfaces to a high degree of parallelism. Slide fixing holes are accurately positioned, allowing customers to pre-drill their mounting holes. All slides are left 'soft' in the center portion for subsequent machining if required. However, since SL2 slides are specially finished to promote resistance to corrosion, customers should be aware that machining may reduce localized corrosion resistance. To maximize corrosion resistance following machining, polishing is recommended. Two varieties of slide are available, spacer type and flat type.

Spacer Slide

A one piece construction that bolts directly to the mounting surface of the machine, providing adequate running clearance for bearing assemblies, cap seals and lubricators. A central keyway is provided for simple location by means

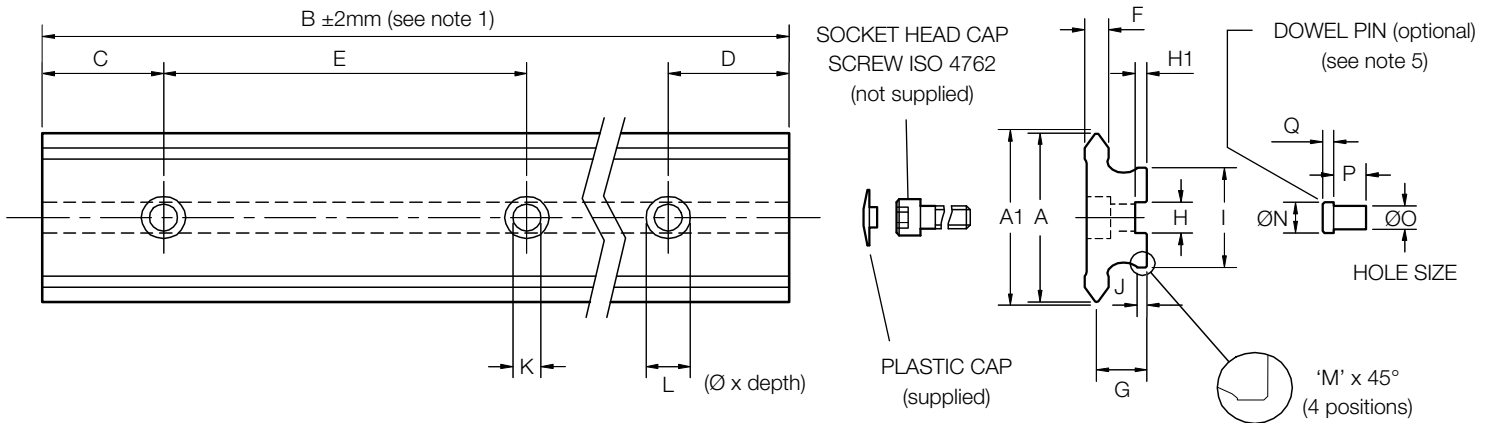

Part Number		Use with Bearing Ø (see note 3)	A ~	A1 Theoretical Apex	B Max (see note 1)	C	D	E ±0.1 Non Acc.	F	G	H +0.05 -0.00	H1	I ±0.025	J
Spacer Slide	Flat Slide													
SS NMS 12		13	12	12.37	1976	20.5	20.5	45	3	6.2	4	1.8	8.5	1.7
	SS MS 12	13	12	12.55	1016	13	13	30	3	-	-	-	-	-
SS NS 25		25	25	25.74	4020	43	43	90	4.5	10	6	2.5	15	2.5
	SS S 25	25	25	25.81	4020	43	43	90	4.7	-	-	-	-	-
	SS S 35	25	35	35.81	4020	43	43	90	4.7	-	-	-	-	-
	SS S 50	25	50	50.83	4020	43	43	90	4.7	-	-	-	-	-
SS NM 44		34	44	44.74	4020	43	43	90	6	12.5	8	3	26	2.5
	SS M 44	34	44	44.81	4020	43	43	90	6.1	-	-	-	-	-
	SS M 60	34	60	60.81	4020	43	43	90	6.1	-	-	-	-	-
	SS M 76	34	76	76.81	4020	43	43	90	6.1	-	-	-	-	-
SS NL 76		54	76	76.74	4020	88	88	180	9	19.5	15	5	50	5
	SS L 76	54	76	76.81	4020	43	43	90	9.1	-	-	-	-	-

CONTINUED ON NEXT PAGE

Notes

- Any length of slide within B Max dimension can be supplied, but for optimum price and delivery time, slide lengths should be specified which maintain the C and D dimensions in the table above. In all cases unless otherwise specified by the customer, C and D dimensions will be supplied equal. Customers are requested to ensure that the proximity of the fixing holes to the ends of the slide will accommodate the fixing screws and to note that slide lengths which bisect the fixing holes will require dimensions C and D to be specified unequal.
- Where longer slides are required, standard lengths can be matched suitable for butting, on request. In these cases the mating ends will be ground square and additional holes may be inserted to give support near the joints. A light stoning of the 'V's will be necessary after installation to ensure smooth travel across the joints.
- In the table, the standard size of bearing diameter to use with each slide is quoted. However, other combinations are possible - please see page 6 note 1 for further details.
- Fixing screws for flat slides must have head length sufficient to clear the carriage. Low head socket cap screws DIN 7984 provide sufficient clearance and are available from Bishop-Wisecarver (see table).
- Slides in their free unmounted state are not necessarily straight. If straightness is important, the slide may be set straight by bolting down against a register or by utilizing the central keyway. If dowel pins are used, these should be positioned one each end midway between the slide end and first hole. Also, midway between all fixing hole centers, or as deemed necessary for the application.

of dowel pins or customer's own key. In cases where cap seals or lubricators are not being used, the precision datum edges on the spacer portion of the slide may be utilized for location against a machined register. The rigidity of the spacer slide enables it to be used as a self-supporting element or construction member of the machine, when used in conjunction with flange clamps (see pages 17 and 22). Plastic caps are provided with all spacer slides to close off debris traps at the hole positions. These caps engage in the sockets of the fixing screws.

Flat Slide

Designed for customers who prefer to bolt the slide to a spacer which is part of their own machine construction. Where the slide is required to be the moving component an aluminum spacer plate can be constructed in order to reduce inertia.

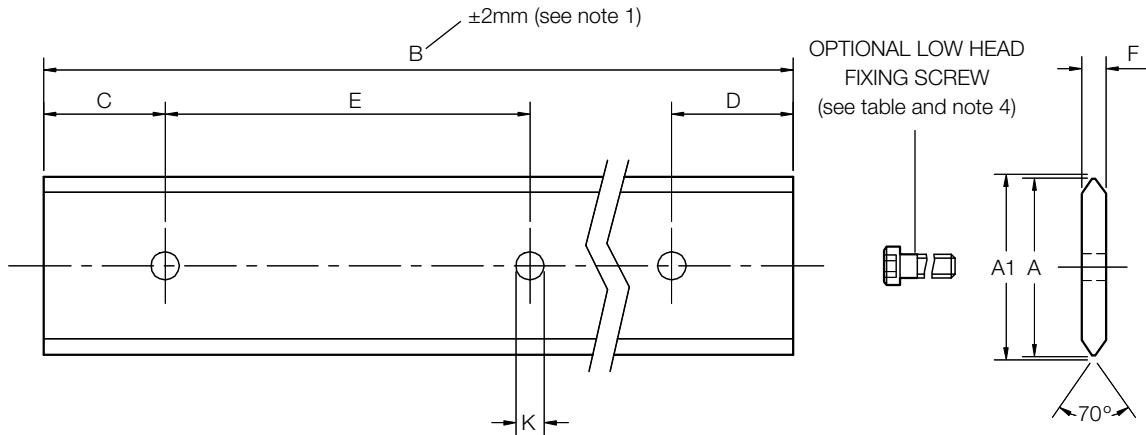

K	L	M	Dowel Pin Option (see note 5)					Flat Slide Fixing Screw (see note 4)			Mass-g /100mm	Part Number		
			Part No.	N m6	O K6	P	Q	Part No.	Thread	Length		Spacer Slide	Flat Slide	
3.5	6 x 3	-	SS SDP 4	4 +0.012 +0.004	4 +0.002 -0.006	6.75	-	-	-	-	44	SS NMS 12		
3.5	-	-	-	-	-	-	-	-	SS FS 3-8	M3	8	23		SS MS 12
5.5	10 x 5	1.0	SS SDP 6	6 +0.012 +0.004	4 +0.002 -0.006	6	2.25	-	-	-	140	SS NS 25		
7	-	-	-	-	-	-	-	-	SS FS 6-16	M6	16	82		SS S 25
7	-	-	-	-	-	-	-	-	SS FS 6-16	M6	16	130		SS S 35
7	-	-	-	-	-	-	-	-	SS FS 6-16	M6	16	170		SS S 50
7	11 x 6	1.0	SS SDP 8	8 +0.015 +0.006	6 +0.002 -0.006	8	2.75	-	-	-	330	SS NM 44		
7	-	-	-	-	-	-	-	-	SS FS 6-20	M6	20	190		SS M 44
9	-	-	-	-	-	-	-	-	SS FS 8-20	M8	20	265		SS M 60
9	-	-	-	-	-	-	-	-	SS FS 8-20	M8	20	340		SS M 76
14	20 x 12	1.0	SS SDP 15	15 +0.018 +0.007	10 +0.002 -0.007	15	4.75	-	-	-	1000	SS NL 76		
11.5	-	-	-	-	-	-	-	-	SS FS 10-25	M10	25	500		SS L 76

Ordering Details

SS NM 44 626 (P)

Part number ('N' denotes the spacer slide option)
 Required length (mm) multiple of hole spacing (E) plus dimensions C and D

Slide required without holes (spacer slide only)

Example:

- 1 x SS NS 25 536
- 6 x SS SDP 6

Sold & Serviced By:

 Stainless steel spacer slide x 536mm long
 6mm Ø head, stainless steel dowel pins
 Toll Free Phone (877) SERV098
 Toll Free Fax (877) SERV099
 Bishop-Wisecarver Corporation 2008. All rights reserved.
sales@electromate.com

Data & Dimensions

Stainless Steel Bearing Assemblies

A number of bearing assembly options are available in order to cater for most design requirements. The through hole fixing type is available in two stud lengths covering most thicknesses of carriage or mounting plate, the short stud version being compatible with the SL2 carriage plates.

The blind hole fixing type allows mounting into a solid machine base where through mounting holes are not possible, or where the thickness of the mounting plate is too great. The blind hole fixing type is also useful where adjustment from the front is preferred, or where access to the opposite side of the mounting hole is restricted.

The blind hole fixing eccentric type bearing assemblies will not accommodate cap seals. However lubricators may be

Through Fixing Type (SS SJ/SS LJ)

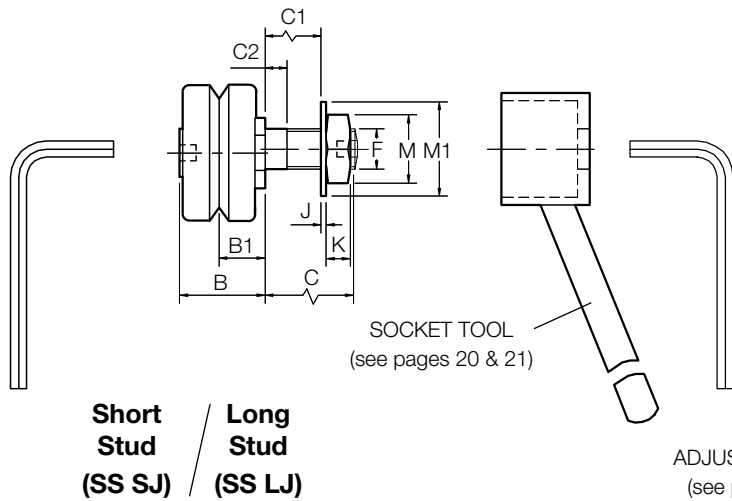

Eccentric (E)

L (see note 3)

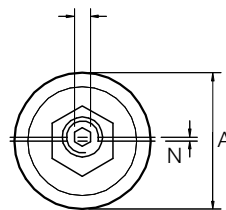

Concentric (C)

O (see note 1)

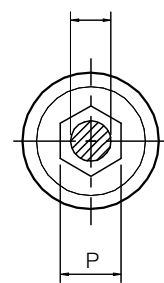

Part Number	For Use With Slide Reference (see note 6)	A	B	B1 ±0.025	SS SJ	SS LJ	SS SJ	SS LJ
					C	C	C1	C1
SS SJ/SS LJ 13 C/E / SS BHJ 13 C/E	MS/NMS	12.7	10.1	5.46	5.8	9.5	3	6
SS SJ/SS LJ 25 C/E / SS BHJ 25 C/E	S/NS	25	16.6	9	9.8	19	4	13
SS SJ/SS LJ 34 C/E / SS BHJ 34 C/E	M/NM	34	21.3	11.5	13.8	22	6	14
SS SJ/SS LJ 54 C/E / SS BHJ 54 C/E	L/NL	54	34.7	19	17.8	30	8	20

Q	R	S	S1	T	T1	T2	U ±0.2	U1	V	W	X	Y
1.5	1.5	6.25	8	8	3.75	6.75	30	47.5	8	20	M3 x 0.5	5.5
3	2	7	8.5	12	5	10	50	72	14	32	M5 x 0.8	8.5
4	2.5	9.5	8.5	17.5	6.5	12.5	60	90.5	17	42	M6 x 1	10
8	3.5	14.5	14	23.5	10.5	18.5	89.5	133	25	62	M8 x 1.25	13

Notes

- It is recommended that holes to suit bearing assembly mounting studs should be reamed to tolerance as per dimension 'R' on page 15.
- Thread form is metric fine. See dimension 'F' in table above.
- All through fixing type eccentric bearing assembly studs are supplied with sockets for adjustment as shown, with the exception of size 13.
- Nuts and washers are supplied with all through fixing type bearing assemblies.
- 'R' dimension is both the eccentric offset of the adjusting nut and the total adjustment available at the bearing center line for 360° rotation of the adjusting nut.
- Each size of bearing assembly has been designed for use with a specific thickness of slide. This is designated within the slide part number by references as shown in the table above. However, any bearing assembly may be used in conjunction with any slide according to practicality of design (see note 1 page 6).
- Double row bearing assemblies are not available for size 13 bearing assemblies.

specified as a means of applying lubrication to the system. Both varieties of bearing assembly are available with two types of bearing configuration. The twin bearing type comprises two individual deep groove ball bearings on a single stud. This construction offers some compliance, which allows smoother running and is more tolerant of misalignment or uneven mounting surface. The double row type (see note 7) is a one piece construction bearing with two ball tracks. This removes potential dirt traps and offers higher load capacity (particularly radially), plus longer life.

Both types of bearing have been designed specially for slide system applications and the performance confirmed by rigorous testing. Their external dimensions are identical.

Blind Hole Fixing Type (SS BHJ)

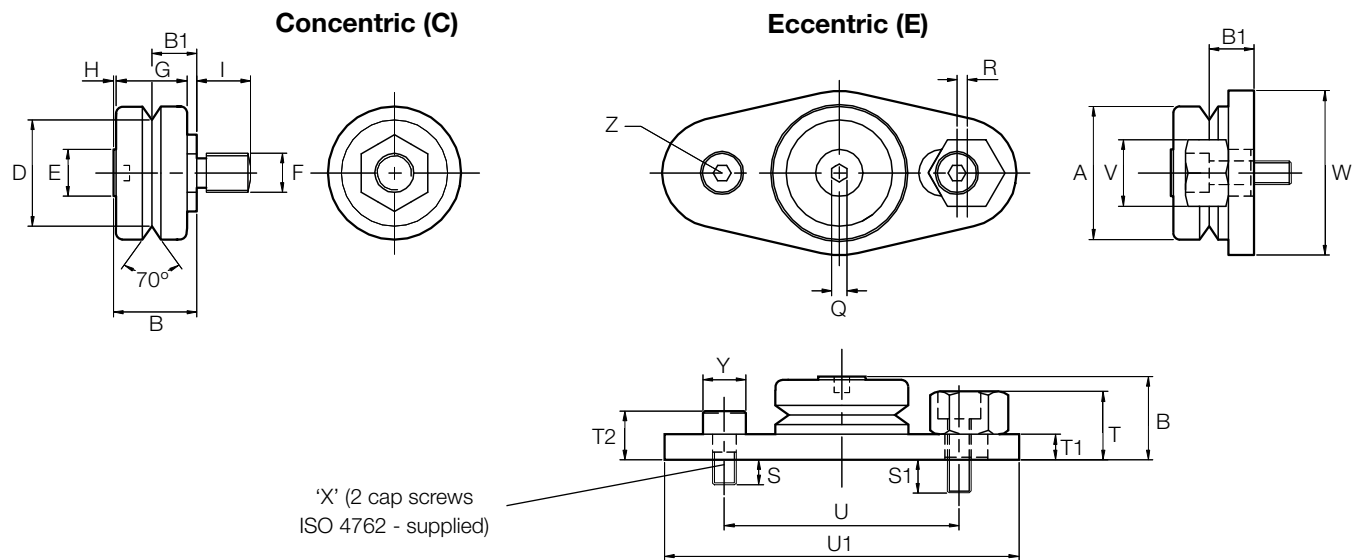

C2	D ±0.025	E	F	G	H	I	J	K	L	M	M1	N	O +0.00 -0.03	P
2.5	9.51	5	M4 x 0.5	8	0.5	6	0.8	2	-	7	9	0.5	4	7
2.5	20.27	10	M8 x 1	14	0.5	10	1	5	3	13	17	0.75	8	13
5.5	27.13	12	M10 x 1.25	18	0.7	14	1.25	6	4	17	21	1.0	10	15.2
6	41.76	25	M14 x 1.5	28	1.6	18	1.6	8	6	22	28	1.5	14	27

Z	Mass ~g				Part Number
	SS SJ C/E	SS LJ C/E	SS BHJ C	SS BHJ E	
8	8	8	7	27	SS SJ/LJ 13 C/E / SS BHJ 13 C/E
10	48	51	43	105	SS SJ/LJ 25 C/E / SS BHJ 25 C/E
14	115	120	105	235	SS SJ/LJ 34 C/E / SS BHJ 34 C/E
20	415	425	390	800	SS SJ/LJ 54 C/E / SS BHJ 54 C/E

Ordering Details

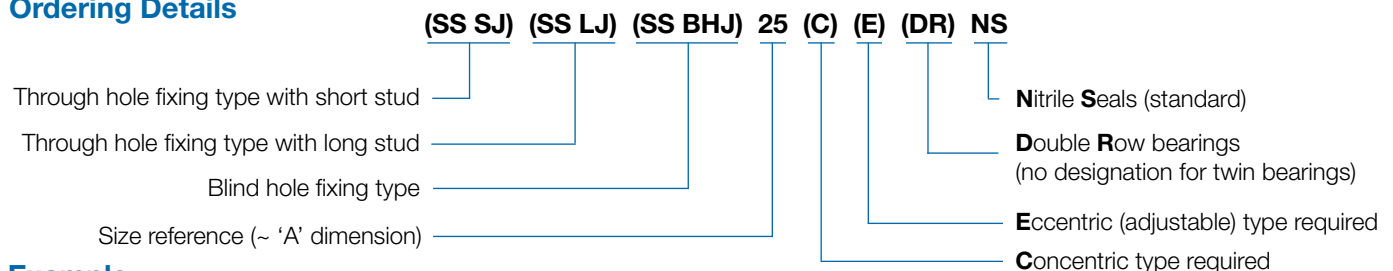

Example:

- 2 x SS SJ 34 C NS Stainless steel short stud size 34 concentric bearing assemblies with twin bearings and standard nitrile seals
- 2 x SS SJ 34 E NS Stainless steel short stud size 34 eccentric bearing assemblies with twin bearings and standard nitrile seals

Sold & Served By:

 Toll Free Phone (877) SERV098
 Toll Free Fax (877) SERV099
 © Bishop-Wisecarver Corporation, 2008. All rights reserved.
 sales@electromate.com

Data & Dimensions

Aluminum Carriage Plates

Lightweight aluminum carriage plates are finished with a proprietary U.S. Dept. of Agriculture approved corrosion resistant coating. For convenience and reliability it is recommended that customers specify complete factory assembled systems (see page 9). Individual carriage plates are available for customers who prefer to carry out their own assembly.

Carriage Plates Type 'A' (will accommodate cap seals or lubricators)

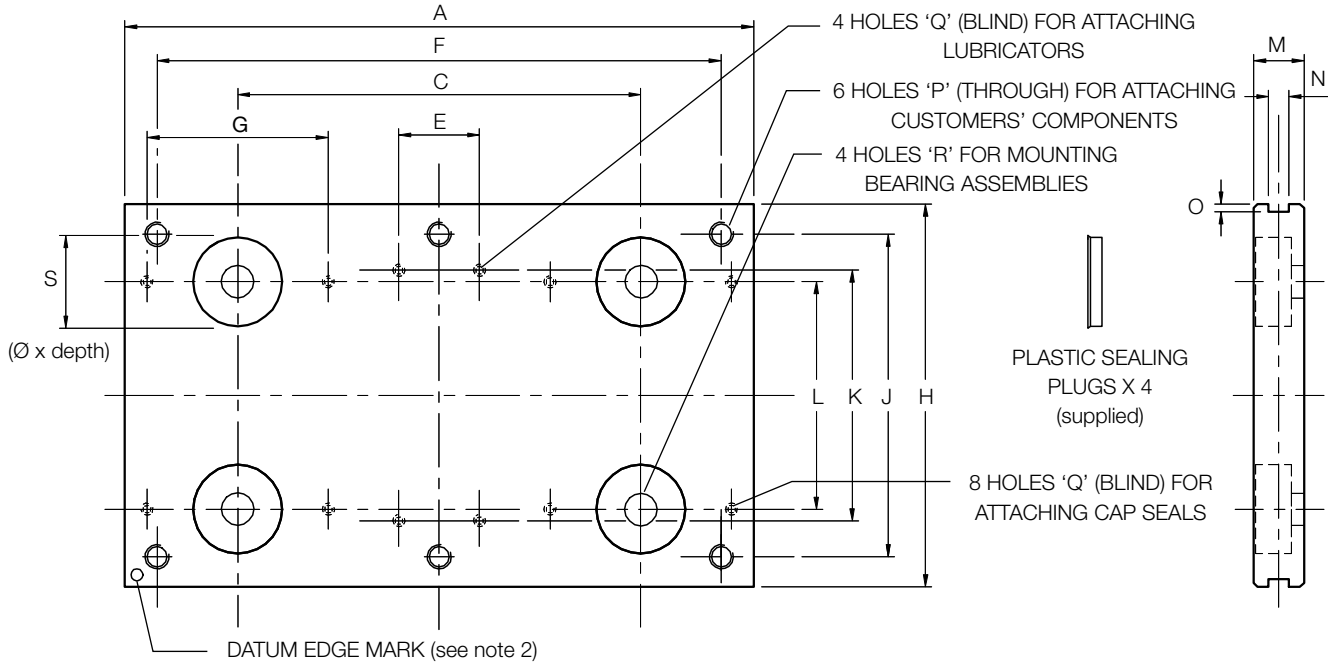

Part Number	For Use With		Type 'A'	Type 'B'	C	D	E	F	G	H
	Slide	Bearing								
SS CP MS12	MS/NMS 12	13		50	35	18	12	-	-	40
				75	60	25		-	-	
				100	85	50		-	-	
SS CP S25	S/NS 25	25		80	51	25	18	-	-	80
				130	72	-		110	45	
SS CP S35	S 35	25		180	120	-	18	160	45	95
				150	90	-		130	45	
				200	140	-		180	45	
SS CP S50	S 50	25		110	80	50	18	-	-	112
				160	100	-		140	45	
SS CP M44	M/NM 44	34		220	160	-	25	200	45	116
				125	88	50		-	-	
				175	103	-		155	56	
SS CP M60	M 60	34		225	153	-	25	205	56	135
				150	110	60		-	-	
				200	125	-		180	56	
SS CP M76	M 76	34		280	205	-	25	260	56	150
				170	130	80		-	-	
				240	165	-		220	56	
SS CP L76	L/NL 76	54		340	265	-	38	320	56	185
				200	140	90		-	-	
				300	198	-		270	80	
			400	298	-		370	80		

CONTINUED ON NEXT PAGE

Notes

- The recesses along the edges of the carriage plate provide a means to locate switch cams or other components.
- The datum edge mark identifies the reference edge used in manufacture. Customers may therefore use this edge as a location to achieve best accuracy in relation to hole positions. It is normal to mount the concentric bearing assemblies on this side.
- Customers constructing their own carriage plate should refer to pages 6 & 7 (Assembled Systems), and drill bearing assembly hole centers according to 'D' dimension and note 2 (bearing assembly centers as per 'D' dimension above are slightly different for reasons of interchangeability with other products from Bishop-Wisecarver).

There is a range of three useful lengths in each size, available in two different types according to whether or not the carriage plate length will accommodate cap seals and lubricators (Type 'A') or lubricators only (Type 'B'). Special carriage plates can be manufactured to customers' drawings, in various materials including most grades of stainless steel.

Carriage Plates Type 'B' (will accommodate lubricators only)

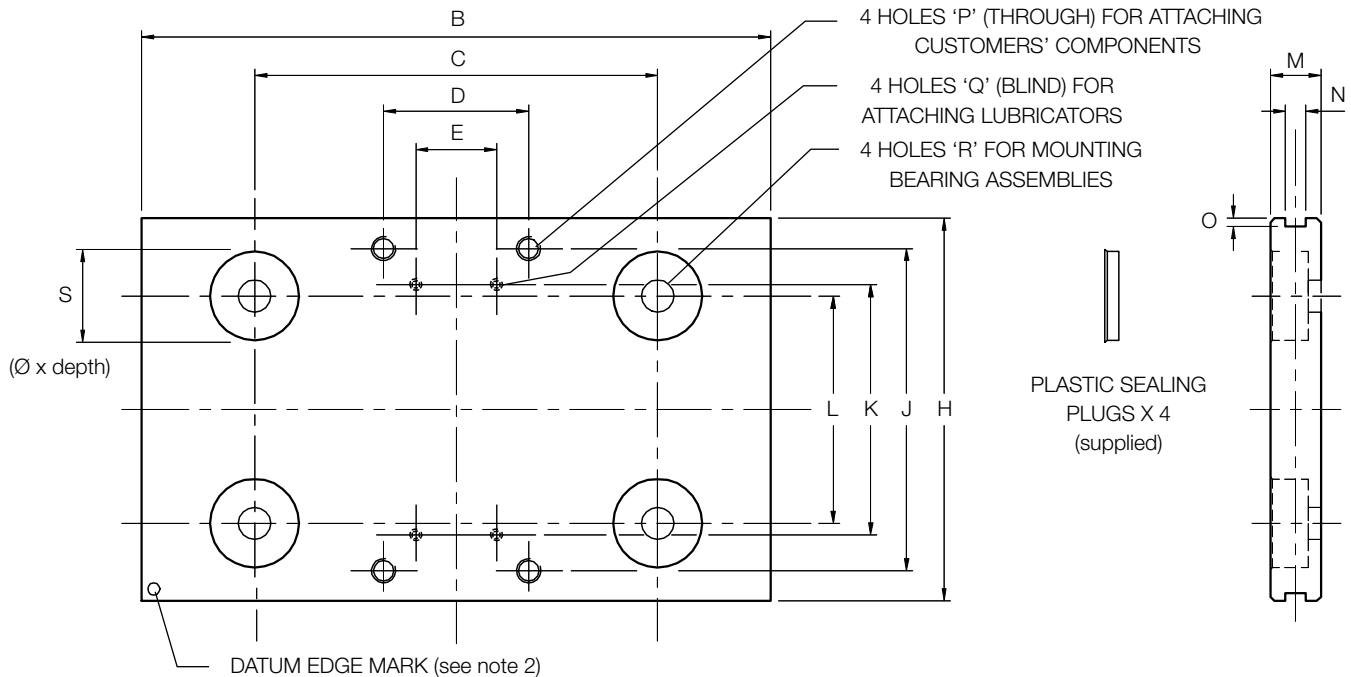

J	K	L (see note 3)	M + 0.08 - 0.00	N O		P	Q	R Ø	S	Mass ~kg	Part Number
				(see note 1)							
30	23	22	7.34	3	1.5	M4 x 0.7	M2.5 x 0.45 x 4	4 +0.008 +0.018	12.5 x 4.8	0.03 0.05 0.06 0.16	SS CP MS12
64	45	46.4	11.5	5	2	M6 x 1.0	M3 x 0.5 x 5	8 +0.010 +0.022	22 x 8.4	0.28 0.4 0.28	
80	55	56.43	12.5	5	2	M6 x 1.0	M3 x 0.5 x 5	8 +0.010 +0.022	22 x 9.4	0.44 0.59	SS CP S35
95	70	71.43	14	5	2	M6 x 1.0	M3 x 0.5 x 5	8 +0.010 +0.022	22 x 10.9	0.41 0.61 0.87	
96	69	72.29	14.5	6	2	M8 x 1.25	M4 x 0.7 x 8	10 +0.010 +0.022	25 x 8.7	0.5 0.71 0.93	SS CP M44
115	85	88.29	17.0	6	2	M8 x 1.25	M4 x 0.7 x 8	10 +0.010 +0.022	25 x 11	0.85 1.13 1.64	
130	101	104.29	18.0	6	2	M8 x 1.25	M4 x 0.7 x 8	10 +0.010 +0.022	25 x 12.5	1.15 1.64 2.37	SS CP M76
160	114	119.06	20.0	8	4	M10 x 1.5	M5 x 0.8 x 7	14 +0.015 +0.027	32 x 13.5	1.81 2.77 3.74	

Ordering Details

SS CP M44 225 (A) (B)

Part number _____ Type 'B' (accommodates lubricators)
 (M44 denotes corresponding slide reference)

Required length (mm) _____ Type 'A' (accommodates lubricators or cap seals)

Example: 1 x SS CP S25 80 B Carriage plate type B to suit an S/NS25 slide (will accommodate lubricators only)

Sold & Serviced By:

Toll Free Phone (877) SERV098
 Toll Free Fax (877) SERV099
 © Bishop-Wisecarver Corporation 2008. All rights reserved.
sales@electromate.com

Data & Dimensions

Cap Seals and Lubricators

Cap Seals

Flexible plastic cap seals fit over the individual bearing assemblies, providing effective sealing and protection, plus wiping of debris from the slide profile. Lubrication of the 'V' surface is provided by means of oil-impregnated felt wipers.

The internal cavity is filled with grease via the lubrication points, further improving lubrication and recharging the felt wipers as the grease partially liquefies under operation. Most systems require no further lubrication during the lifetime of the machine (see note 3). Furnishing of these seals increases load, life and linear speed capability as well as improving operator safety.

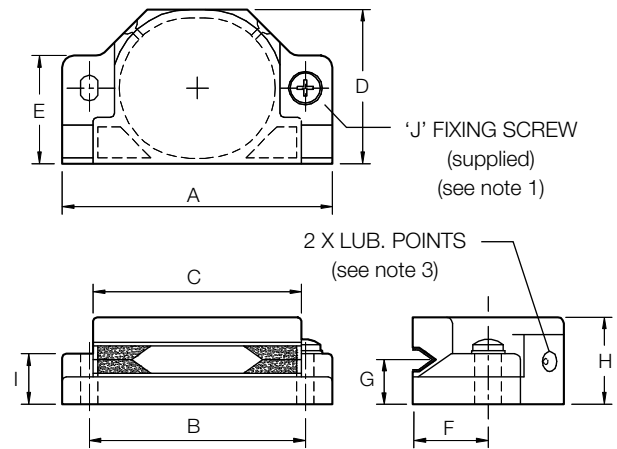

Part Number	Use With Bearing Ø/Slide Ref.	A	B	C	D	E	F	G	H	I	J	Mass ~g
SS CS 25	25 / S/NS	55	45	43	30	22	14.8	9	18	8.5	M3 x 0.5 x 12	13
SS CS 34	34 / M/NM	70	56	54	40	28	19.6	11.5	22.5	13	M4 x 0.7 x 20	28
SS CS 54	54 / L/NL	98	80	78	60	40	29.7	19	36.5	20	M5 x 0.8 x 25	78

Notes

- 2 x stainless steel cross recessed cheese head screws DIN84A and washers DIN125A are supplied with each cap seal.
- Cap seals are designed for use with particular bearing assemblies (see table). They are normally used in conjunction with the slide section as specified in the table. However, these may also be used with any slide of greater thickness (see pages 10 & 11, dimension 'F').
- Replenish lubricant as necessary using a No.2 consistency lithium soap based grease. Male grease connector Part No. CSCHF4034 or complete gun available from Bishop-Wisecarver if required. Lubrication interval depends on length of stroke, duty and environmental factors.

Ordering Example: State quantity and part number: 4 x SSCS34

Lubricators

Plastic lubricators normally fit one each side of the slide between pairs of bearing assemblies. However, any number may be fitted, in any position according to requirements. Lubricators provide positive lubrication to the working surface of the slide by means of spring-loaded oil-impregnated felt wipers which act as a reservoir.

System load capacity and life expectancy are significantly increased while retaining the low friction characteristics of dry running. Lubricators may be used with any SL2 carriage plate, and are the only choice for miniature systems (SSNMS/MS12 slides with SSSJ13 bearing assemblies). They are also required, for lubrication purposes, if the BHJ blind hole fixing eccentric bearing assemblies are used.

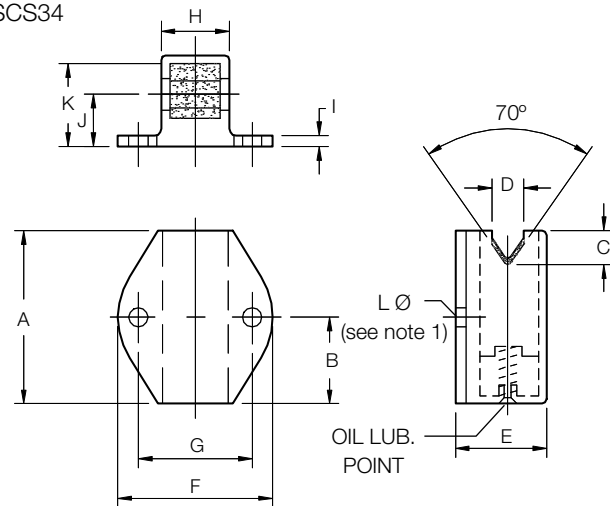

Part Number	Use With Slide (note 2)	A	B	C	D	E	F	G	H	I	J	K	L Ø	Fixing Screw	Mass ~g
SS LB 13F	SS MS/NMS	13	6.5	2.2	3.1	10	17	12	5.2	2	5.46	9	2.7	M2.5 x 0.45 x 5	2
SS LB 25F	SS S/NS	28	14	5.5	5.5	16.5	25	18	9.9	2	9	15.25	3.2	M3 x 0.5 x 6	6
SS LB 44F	SS M/NM	38	19	8	7	20	34	25	15	2.4	11.5	18.25	4.2	M4 x 0.7 x 10	16
SS LB 76F	SS L/NL	57	28.5	11.5	10	33.5	50	38	22.7	4.5	19	31.5	5.2	M5 x 0.8 x 10	44

Notes

- 2 x stainless steel cross recessed cheese head screws DIN84A are supplied with each lubricator.
- Lubricators are designed for use with particular bearing assemblies (see table). They are normally used in conjunction with the slide section as specified in the table. However, they may also be used with any slide of lesser thickness (see pages 10 & 11, dimension 'F').
- Replenishment of oil should be carried out via the lubrication point using 68 viscosity EP mineral oil. Lubrication interval depends on length of stroke, duty and environmental factors but is typically 700 Km of linear travel.

Ordering Example: State quantity and part number: 4 x SSLB25F

Sold & Serviced By:

 Toll Free Phone (877) SERV098

 Toll Free Fax (877) SERV099

www.electromate.com

sales@electromate.com

Aluminum Flange Clamps

Flange clamps enable the slide system to act as a self-supporting constructional element of the machine. Manufactured from aluminum alloy, the clamps are then treated with a corrosion resistant coating certified by the U.S. Department of Agriculture. They are available for use with SS NS25, SS NM44, and SS NL76 section spacer slides only. **Short Flange Clamps** (type **SFC**) enable the slide to be supported between two opposing faces. The **Long Flange Clamp** (type **LFC**) enables short lengths of slide to be supported from one end only. The machined base mounting facility may be utilized by customers wishing to space the slide system away from the mounting surface. For application illustration see page 4. For slide deflection calculations, when used as a machine construction member, see page 20.

Assembly

During assembly, care should be taken to ensure that the flange clamps are positioned proud of the ends of the slide (see note 1). Flange fixing screws should be located and slightly tightened, before clamping screws 'M' are fully tightened. Progressive tightening of each screw 'M' is recommended. Flange fixing screws may then be fully tightened.

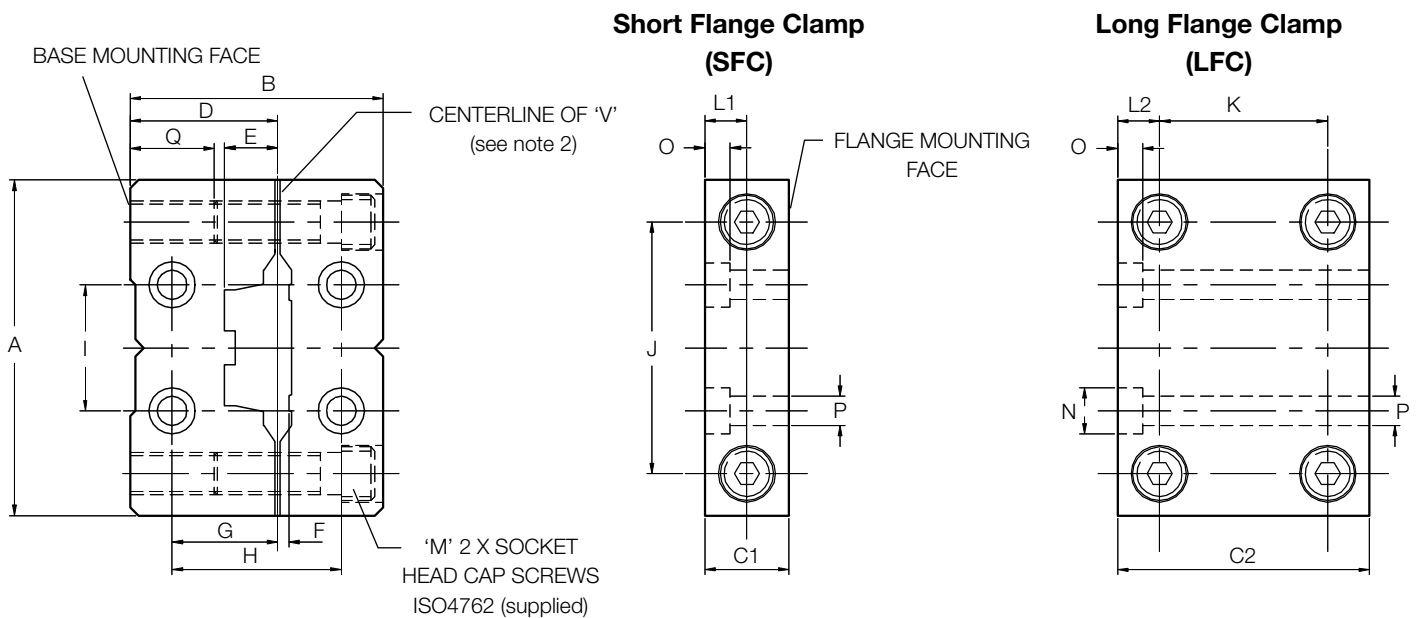

Part Number	For Use With Slide	A	B	C1	C2	D ±0.1	E	F	G	H ±0.2	I ±0.2	J	K	L1	L2	M	N	O	P	Q	Mass ~g	
																					SFC	LFC
SS SFC/LFC 25	SS NS 25	60	55	15	55	30	10	1.8	20	35	20	45	35	7.5	10	M6 x 30	9.5	5	6	17	120	405
SS SFC/LFC 44	SS NM 44	80	60	20	60	35	12.5	2.5	25	40	30	60	40	10	10	M8 x 30	11	6	7	20	220	630
SS SFC/LFC 76	SS NL 76	120	75	25	75	45	19.5	4	30	50	55	95	50	12.5	12.5	M10 x 40	14	8	9	23	495	1425

Ordering Details

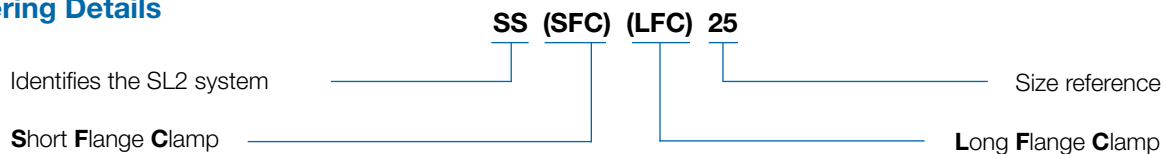

Example: 2 x SS SFC 44 **Short Flange Clamps** for use with slide SSNM44
 (Slide generally ordered with no holes 'P' option when using flange clamps - see page 11)

Notes

- For mounting slides between opposing faces, slides should be ordered 2mm shorter than the required span.
- The drawings show dimensions from the centerline of slide 'V' when in the clamped condition. The keyway register ensures slide is located centrally.

Technical Data

Life/Load Calculations

Maximum moment and direct load capacities for the SL2 system are given in the table below. Capacities are given for 'dry' and 'lubricated' conditions - this refers to the 'V' contact, since all bearing assemblies are greased for life internally. Values are based on shock-free duty.

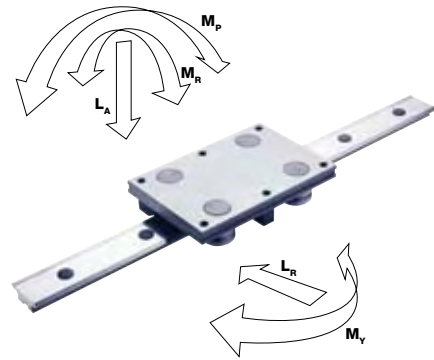

Carriage Type	Dry System, Twin & DR Type Bearing					Lubricated System, Twin Type Bearing					Lubricated System, DR Type Bearing				
	L _{A(max)} N	L _{R(max)} N	M _{R(max)} Nm	M _{Y(max)} Nm	M _{P(max)} Nm	L _{A(max)} N	L _{R(max)} N	M _{R(max)} Nm	M _{Y(max)} Nm	M _{P(max)} Nm	L _{A(max)} N	L _{R(max)} N	M _{R(max)} Nm	M _{Y(max)} Nm	M _{P(max)} Nm
SSCPMS12	80	80	0.4	40 x Y	40 x Y	240	240	1.3	120 x Y	120 x Y	Not Applicable				
SSCPS25	320	320	3.6	160 x Y	160 x Y	960	960	11	480 x Y	480 x Y	1600	3000	17	1500 x Y	800 x Y
SSCPS35	320	320	5	160 x Y	160 x Y	960	960	15	480 x Y	480 x Y	1600	3000	25	1500 x Y	800 x Y
SSCPS50	320	320	7.3	160 x Y	160 x Y	960	960	22	480 x Y	480 x Y	1600	3000	37	1500 x Y	800 x Y
SSCPM44	640	640	13	320 x Y	320 x Y	3000	3000	60	1500 x Y	1500 x Y	3600	6000	72	3000 x Y	1800 x Y
SSCPM60	640	640	18	320 x Y	320 x Y	3000	3000	84	1500 x Y	1500 x Y	3600	6000	100	3000 x Y	1800 x Y
SSCPM76	640	640	23	320 x Y	320 x Y	3000	3000	108	1500 x Y	1500 x Y	3600	6000	129	3000 x Y	1800 x Y
SSCPL76	1440	1440	50	720 x Y	720 x Y	6000	6000	210	3000 x Y	3000 x Y	8000	10000	280	5000 x Y	4000 x Y

Calculating System Life

To calculate system life, the load factor L_F should be calculated using the equation below. Where M_P and M_Y moment loads are concerned, the M_{P(max)} and M_{Y(max)} for the relevant carriage plate will need to be determined. This is established by multiplying the figure shown in the table by the spacing of the bearing assemblies, Y, in meters.

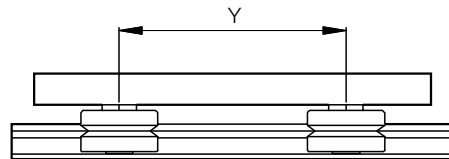

$$L_F = \frac{L_A}{L_{A(max)}} + \frac{L_R}{L_{R(max)}} + \frac{M_R}{M_{R(max)}} + \frac{M_Y}{M_{Y(max)}} + \frac{M_P}{M_{P(max)}}$$

L_F should not exceed 1 for any combination of loads.

Once L_F is calculated, the life in km can be calculated using one of the two equations below, with Basic Life being taken from the table for the bearing assembly and lubrication condition applicable.

Bearing Assemblies	Basic Life Lubricated	Basic Life Dry
SS SJ/LJ/BHJ 13	40	40
SS SJ/LJ/BHJ 25	40	70
SS SJ/LJ/BHJ 25 DR	70	70
SS SJ/LJ/BHJ 34	100	100
SS SJ/LJ/BHJ 34 DR	150	100
SS SJ/LJ/BHJ 54	200	150
SS SJ/LJ/BHJ 54 DR	400	150

Dry System

$$\text{Life (km)} = \frac{\text{Basic Life}}{(L_F)^2}$$

Lubricated System

$$\text{Life (km)} = \frac{\text{Basic Life}}{(L_F)^3}$$

Sold & Serviced By:



Toll Free Phone (877) SERV098

Toll Free Fax (877) SERV099

www.electromate.com

sales@electromate.com

Life/Load Calculation Examples

Example 1

An SSCPS25 130 carriage plate is fitted with SSSJ25 twin type bearing assemblies and SSCS25 cap seals, mounted on an SSNS25 spacer slide. The carriage carries a load of 30N offset from the centerline by 50mm as shown.

$$L_A = 30N$$

$$M_R = L_A \times 0.05 = 30 \times 0.05 = 1.5Nm$$

$$L_R = M_Y = M_P = 0$$

$$L_F = \frac{30}{960} + \frac{0}{960} + \frac{1.5}{11} + \frac{0}{(480 \times Y)} + \frac{0}{(480 \times Y)} = 0.168$$

Basic life for a lubricated system using SSSJ25 twin type bearing assemblies is 40km.

$$\text{Life (km)} = \frac{40}{0.168^3} = \mathbf{8436km}$$

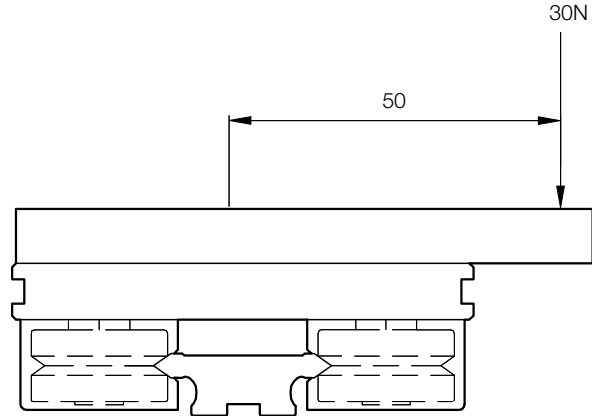

Example 2

An SSCPM44 175 carriage plate is fitted with SSSJ34DR double row bearing assemblies and SSCS34 cap seals, mounted on an SSNM44 spacer slide. The carriage carries a load of 200N offset from the centerline by 150mm as shown.

$$L_A = 200N$$

$$M_P = L_A \times 0.15 = 200 \times 0.15 = 30Nm$$

$$L_R = M_R = M_Y = 0$$

Using carriage plate SSCPM44 175, Y = 0.103m

$$M_{P(max)} = 1800 \times 0.103 = 185.4Nm$$

$$L_F = \frac{200}{3600} + \frac{0}{6000} + \frac{0}{72} + \frac{0}{(3000 \times Y)} + \frac{30}{185.4} = 0.217$$

Basic life for a lubricated system using SSSJ34DR double row bearing assemblies is 150km.

$$\text{Life (km)} = \frac{150}{0.217^3} = \mathbf{14680km}$$

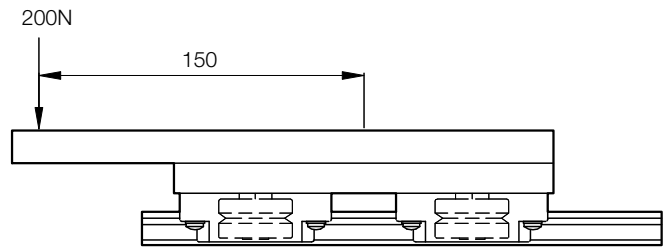

Example 3

An SSCPL76 300 carriage plate is fitted with SSSJ54 twin type bearing assemblies mounted on an SSNL76 spacer slide. The 'V' contact surface is dry. The system is raised and lowered using a ballscrew as shown. The mass being lifted is 30kg.

For system equilibrium, upward force F_1 must equal downward force F_2 ($30kg \times 9.81$) = 294.3N

F_1 gives clockwise moment, F_2 gives counter-clockwise moment.

$$M_P = (294.3 \times 0.12) - (294.3 \times 0.06) = 17.66Nm$$

$$L_A = L_R = M_R = M_Y = 0$$

Using carriage plate SSCPL76 300, Y = 0.198

$$M_{P(max)} = 720 \times 0.198 = 142.5Nm$$

$$L_F = \frac{0}{1440} + \frac{0}{1440} + \frac{0}{50} + \frac{0}{(720 \times Y)} + \frac{17.6}{142.5} = 0.124$$

Basic life for a dry system using SSSJ54 twin type bearing assemblies is 150km.

$$\text{Life (km)} = \frac{150}{0.124^2} = \mathbf{9755km}$$

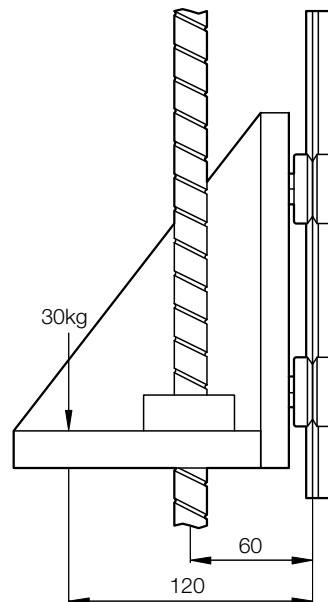

Sold & Serviced By:



Toll Free Phone (877) SERV098
Toll Free Fax (877) SERV099

Technical Data

Deflection of Self-Supporting Slides

When SL2 system slides are used as self-supporting beams (in conjunction with flange clamps - see page 17) in the construction of machines, the slides will deflect under load. Care should be taken when designing an installation to take account of this deflection, choosing a slide section which will give both adequate life and satisfactory stiffness for the duty.

The deflection of a slide beam across a span (as shown opposite), will be a maximum at the center of the span when the load passes over this point. This maximum deflection is given by the following equation:

$$(1) \quad d = \frac{FL^3}{48EI}$$

The deflection of a slide beam acting as a cantilever and using a long flange clamp (as shown opposite), will be a maximum at the free end when the load is at the outermost extremity of its stroke. This maximum deflection is given by the following equation:

$$(2) \quad d = \frac{FL^2(3L - k)}{6EI} + FLkRc$$

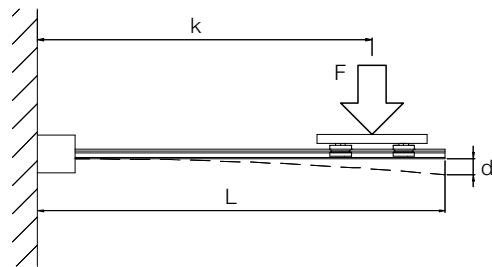
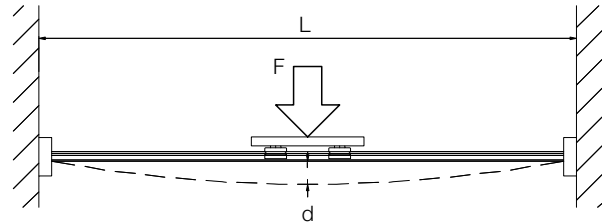

Slide Section	EI horizontal*	EI vertical*	Rc
SSNS25	4.2×10^8	1.2×10^9	1.3×10^{-7}
SSNM44	1.3×10^9	9.0×10^9	4.0×10^{-8}
SSNL76	1.1×10^{10}	7.0×10^{10}	1.4×10^{-8}

* The orientation refers to the plane of the slide which is resisting the bending forces applied. See figure opposite.

In the equations (1) and (2) above, L, k and d are the dimensions shown in the relevant diagrams (in mm) and F is the load applied in Newtons. The term Rc is a constant relating to the stiffness of the flange clamp, and EI is the product of the material's Young's modulus and the section moment of inertia, which is a constant relating to the stiffness of the slide section in the orientation of the application*. These constants are given for the various systems in the table below.

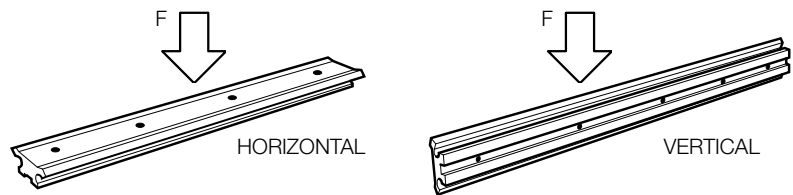

Example 1

SS NM 44 slide used across a span with the load acting on the horizontal plane. Uses two SS SFC 44 flange clamps. F = 700N, L = 600mm. From equation (1), deflection is:

$$\frac{700 \times 600^3}{48 \times 1.3 \times 10^9} = 2.4\text{mm}$$

Example 2

SS NL 76 slide used in a cantilever application with the load acting on the horizontal plane. Uses one SS LFC 76 flange clamp. F = 1500N, L = 350mm, k = 250mm. From equation (2), deflection is:

$$\frac{1500 \times 350^2 \times (3 \times 350 - 250)}{6 \times 1.1 \times 10^{10}} + 1500 \times 350 \times 250 \times 1.4 \times 10^{-8} = 4.1\text{mm}$$

Notes

- The deflections calculated are for static loadings. In some situations dynamic loading may increase the amount of bend.
- Slide beam installations will be stiffer with the slide orientated so that the widest section resists bending. Care should be taken in such applications to ensure that offset loads do not cause excessive bending in the weaker perpendicular plane.

Technical Specifications

Slideways

Material and Finish:	Special martensitic stainless steel conforming generally to AISI 420 series, ground on all main surfaces to N5.
Hardness of 'V' Surface:	Generally 52 HRC
Straightness:	Generally 0.2mm/m unmounted (see note below)
Parallelism:	'V' and datum faces 0.013mm/m non-accumulative
Hole Pitch Tolerance:	± 0.1mm non-accumulative

Bearing Assemblies

Bearing Raceways and Balls:	Stainless steel AISI 440C
Hardness:	58-62 HRC
Seals:	Nitrile rubber
Cage:	Plastic
Studs:	Stainless steel AISI 303
BHJ 'E' Baseplate:	Stainless steel AISI 316
Temperature Range:	-20°C to +120°C
Grease:	Lithium soap grease NLGI 2

Carriage Plate

Material:	High strength aluminum alloy
Finish:	U.S. Department of Agriculture approved surface treatment

Cap Seal

Material:	Body: Thermoplastic elastomer Inserts: Impact resistant plastic Wipers: Felt
Temperature Range:	-20°C to +60°C

Lubricator

Material:	Impact resistant plastic with felt wiper
Temperature Range:	-20°C to +60°C

Flange Clamp

Material:	High strength aluminum alloy
Finish:	U.S. Department of Agriculture approved surface treatment

Fixing Screws, Nuts and Washers

Material:	Stainless steel grades AISI 304 or 316
-----------	--

Counterbore Plugs

Material:	Plastic
-----------	---------

Frictional Resistance

Coefficient of friction (without cap seals or lubricators) = 0.02	
Cap seals and lubricators add friction as follows:	
4 Cap Seals per Carriage:	SSCS25 = 7N, SSCS34 = 15N, SSCS54 = 28N
2 Lubricators per Carriage:	SSLB13 = 1N, SSLB25 = 2.5N SSLB34 = 3N, SSLB54 = 4N

External Lubrication

Cap seals should be lubricated with EP grease NLGI consistency No. 2.
Lubricators should be oiled using EP oil. Food compatible lubricants can also be used.

Maximum Linear Speeds

Lubricated = 5 meters per second, depending upon duty and environmental conditions.

Notes

- The straightness figure quoted above for slides is for the unmounted condition. Slides can be set straight during the assembly process.

Installation

System Assembly and Adjustment

Through Fixing Type Bearing Assemblies

Having loosely assembled the components (minus load), the concentric bearing assemblies should be fully tightened and the eccentric bearing assemblies tightened just sufficiently to permit adjustment. The adjusting wrench should then be engaged with the hexagon flanges of the eccentric bearing assemblies, and gradually turned until the slide is captivated between each pair of opposing bearing assemblies such that there is no apparent play, but with minimal pre-load. Each pair of bearing assemblies should then be checked for correct pre-load by rotating one of them between forefinger and thumb with the slide stationary so that the bearing skirts against the slide. A degree of resistance should be felt, but the bearing should be able to be rotated without difficulty.

When all eccentric bearing assemblies have been adjusted and tested in this manner, the fixing nuts should be fully tightened to the recommended torque settings in the table on page 23, then checked again for correct pre-load as before.

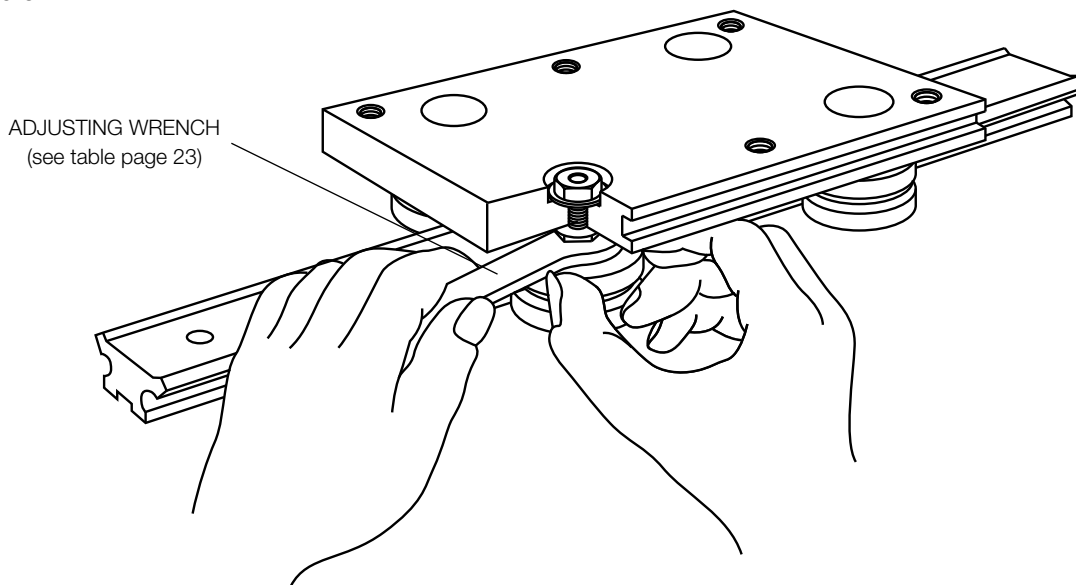

Alternative Method of Adjustment

The eccentric bearing assemblies may also be adjusted using standard Allen key and socket tool. This method also permits re-adjustment without first having to remove the cap seals, however extreme care should be taken not to induce excessive pre-load which can only be judged in this case from the resulting friction of the system. Due to the reduced control associated with this method, it is only recommended when the adjusting wrench method is not possible.

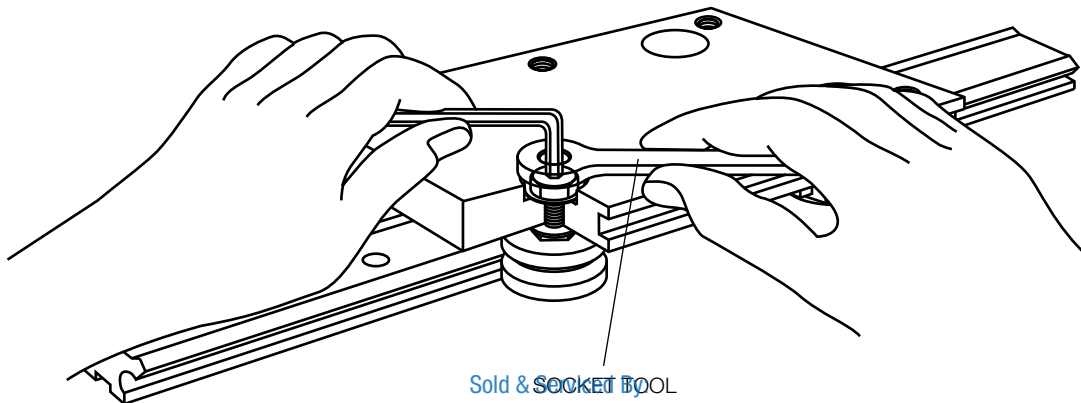

Sold & Socket TOOL
See table page 23
ELECTROMATE

Toll Free Phone (877) SERV098
Toll Free Fax (877) SERV099
www.electromate.com
sales@electromate.com

Blind Hole Fixing Type Bearing Assemblies

The concentric blind hole fixing bearing assemblies are simply screwed into tapped holes in the mounting surface and tightened down using the adjusting wrench.

Each eccentric bearing assembly should be located by means of the two fixing screws provided and tightened just sufficiently to still enable adjustment via the eccentric hexagon bushing. The same basic procedures as outlined for the through fixing type bearing assemblies should be used to ensure that the correct level of pre-load is applied to the bearings, before finally tightening down the fixing screws.

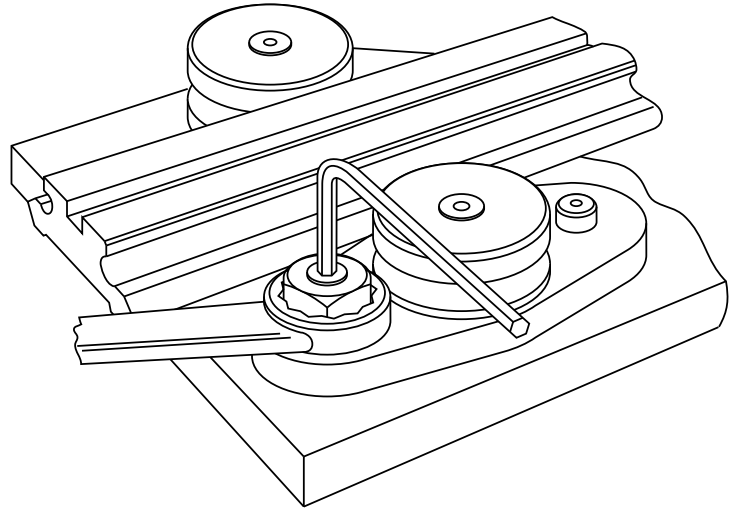

Cap Seal Assembly and Adjustment

Fitting of the cap seals should be carried out after the bearing assembly adjustment has been completed. To fit the cap seals over the bearings, the carriage plate should be removed from the slide, then the cap seals loosely assembled to the carriage plate by means of the screws provided.

The carriage may then be returned to the slide and each cap seal adjusted in, to just make contact with the slide 'V' surface until smearing of the lubricant is observed while operating.

Greater sealing effect, at the expense of increased friction, may be achieved by adjusting each cap seal body in further until its 'V' profile makes contact with the 'V' profile of the slide.

The fixing screws should be fully tightened and each cap seal charged with a No. 2 lithium soap based grease.

Male grease connector, Part No. CSCHF 4034 or complete gun is available from Bishop-Wisecarver if required.

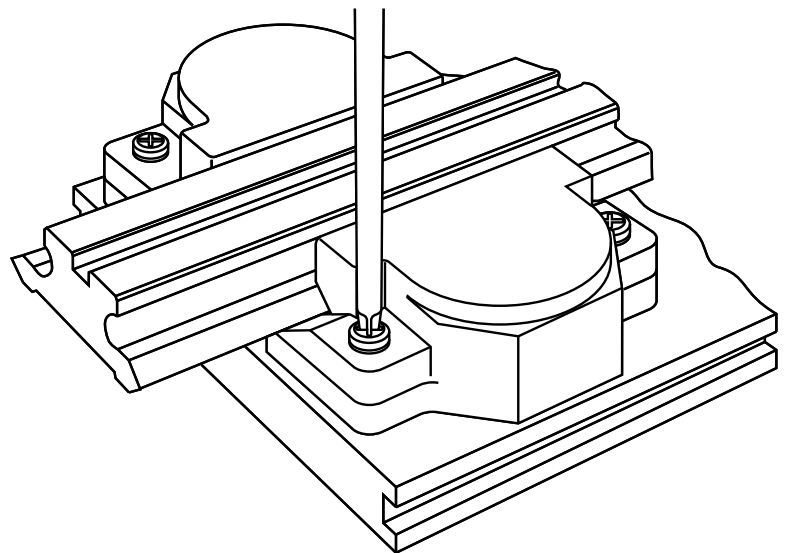

Bearing Assembly Adjusting Tools and Tightening Torques

When ordering individual components for the first time, bearing assembly adjusting tools should also be ordered - these are only available from Bishop-Wisecarver.

Bearing Assembly Type	SS SJ/LJ 13	SS SJ/LJ 25	SS SJ/LJ 34	SS SJ/LJ 54
Adjusting Wrench	AT12	AT25	AT34	AT54
Socket Tool	-	RT8	RT10	RT14
Fixing Nut Torque	2Nm	13Nm	33Nm	90Nm



Toll Free Phone (877) SERV098
Toll Free Fax (877) SERV099

Application Data Sheet

Company: _____

Contact: _____

Address: _____

City: _____ State: _____ Zip Code: _____

Phone: _____ Fax: _____ e-mail: _____

System Orientation: _____

horizontal

vertical

Load: _____

lbs

N

Mass Size (l x w x h): _____

in

m

Stroke Length: _____

in

m

Velocity: _____

in/s

m/s

Accel/Decel: _____

in/s²

m/s²

Linear Accuracy: _____

in/ft

mm/m

Repeatability: _____

in

mm

Duty Cycle: _____

in/day

m/day

Environment: _____

factory

food grade

clean room

other

Temperature: _____

°F

°C

Additional Forces: _____

lbs

N

Product/Machine Description: _____

Additional Requirements: _____

Expected Volume: _____ Date Needed: _____

BISHOPWISECARVER®

System Sketch

Sold & Serviced By:



Toll Free Phone (877) SERV098

Toll Free Fax (877) SERV099

© Bishop-Wisecarver Corporation 2008. All rights reserved.

sales@electromate.com

Bishop-Wisecarver Corporation: Manufacturer of the original DualVee® guide wheel and industry leader in guided motion technology, and exclusive North and Central American partner and distributor for HepcoMotion products since 1984.

BISHOPWISECARVER®

3D CAD DRAWINGS

Bishop-Wisecarver

DualVee® Guide Wheels
LoPro® Linear Motion System
MadeWell® Crown Rollers
MinVee® Linear Slide System
UtiliTrak® Linear Motion Guide

GOT A TOUGH APPLICATION CHALLENGE?

PRODUCT ORDERS



HepcoMotion®

DAPDU2 Double Acting Profile Driven Unit
DLS Driven Linear System
DTS Driven Track System
GV3 Linear Guidance and Transmission System
HDCB Heavy Duty Compact Beam
HDCS Heavy Duty Compact Screw
HDLS Heavy Duty Driven Linear System
HDRT Heavy Duty Ring Slides and Track System
HDS Heavy Duty Slide System
MHD Heavy Duty Track Roller Guidance System
MCS Machine Construction System
PDU2 Profile Driven Unit
PRT Precision Ring and Track System
PSD120 Profile Screw Driven Unit
SBD Sealed Belt Drive
Simple-Select®
SL2 Stainless Steel Based Slide System

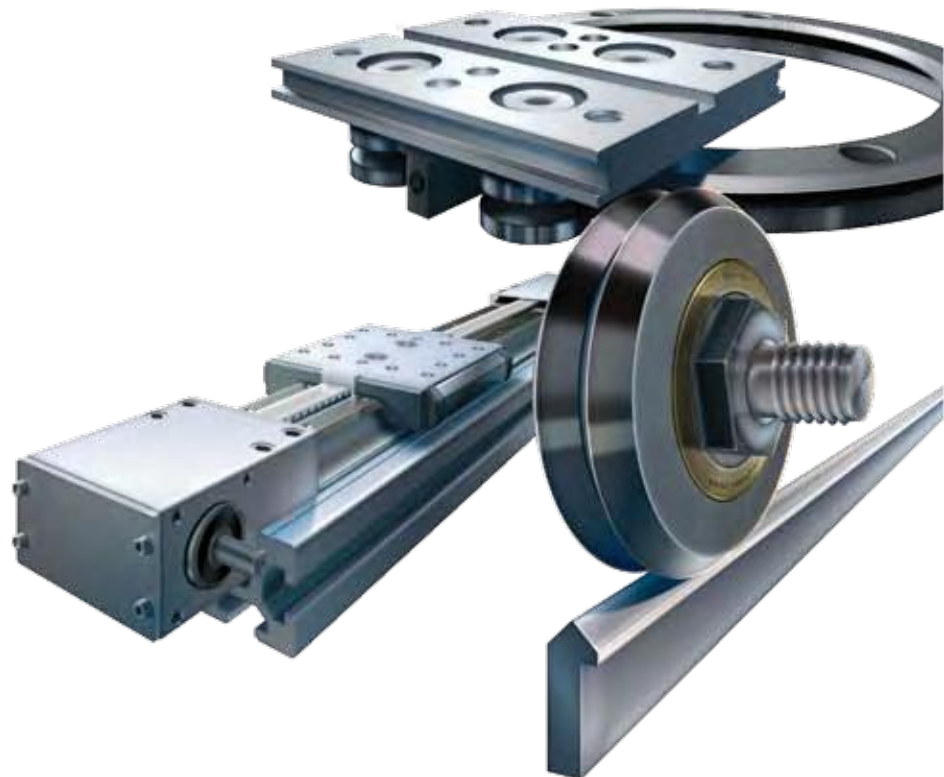

Sold & Serviced By:



Toll Free Phone (877) SERV098
Toll Free Fax (877) SERV099
www.electromate.com
sales@electromate.com