

HepcoMotion®

PSD80

screw driven linear actuator



HEPCO®

Sold & Serviced By:

 **ELECTROMATE**

Toll Free Phone (877) SERV098

Toll Free Fax (877) SERV099

www.electromate.com

sales@electromate.com

Introduction

The **HepcoMotion® PSD80** is a new screw driven linear unit, which is a companion to the popular and cost-effective PDU2 range of belt driven units, and to the larger PSD120 unit.

It shares the PDU2's use of Hepco Herculane® wheels running inside a profile and is actuated by a stainless steel leadscrew with a bearing quality polymer nut. Ballscrew versions are available on request. The closed unit is fully covered with a stainless steel sealing band.

Screw leads of 4, 15, 25 & 70mm are available, meaning that carriage speeds from zero up to ~1m/s are possible without the need for additional gearing  10.





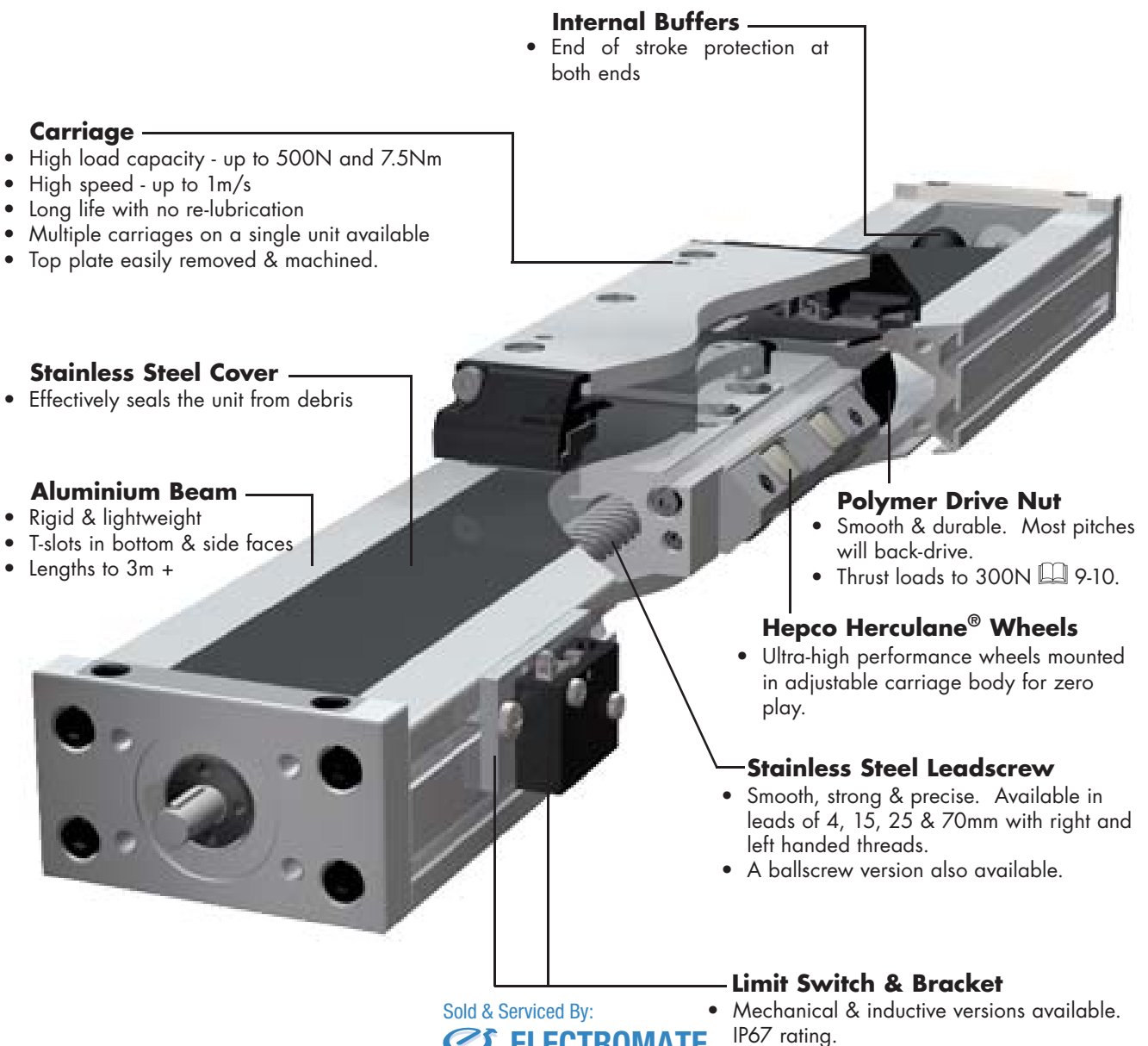

PSD80 carriages have a substantial 500N load capacity, and are also capable of thrust loads of 300N  9 - 10.

The PSD80 beam profile is compatible with the Hepco MCS aluminium frame construction system, and can be assembled into multi-axis systems with Hepco PDU2 and PDU2M units  3 - 4.

PSD80 Closed Unit



PSD80 linear modules include many useful variants to provide a comprehensive and flexible range.

- The closed unit is rugged, tolerant of debris, and has many mounting options  5.
- The open version is compact, light, has low friction, and is lower in cost than the closed unit  6.
- A "slave axis" without the driving screw is available for both closed and open units  5 - 6.
- Units may be specified with any number of carriages  5 - 7.
- A "double acting" version of the unit is available in which two or more carriages move symmetrically about the middle of the beam  7.
- A corrosion resistant version is available with all ferrous parts made from stainless steel.
- Axes with ballscrews (instead of leadscrews) are available on request.
- Dedicated carriage designs are available to facilitate multi- axis connections  3, 4, 8.

PSD80 Double Acting Unit

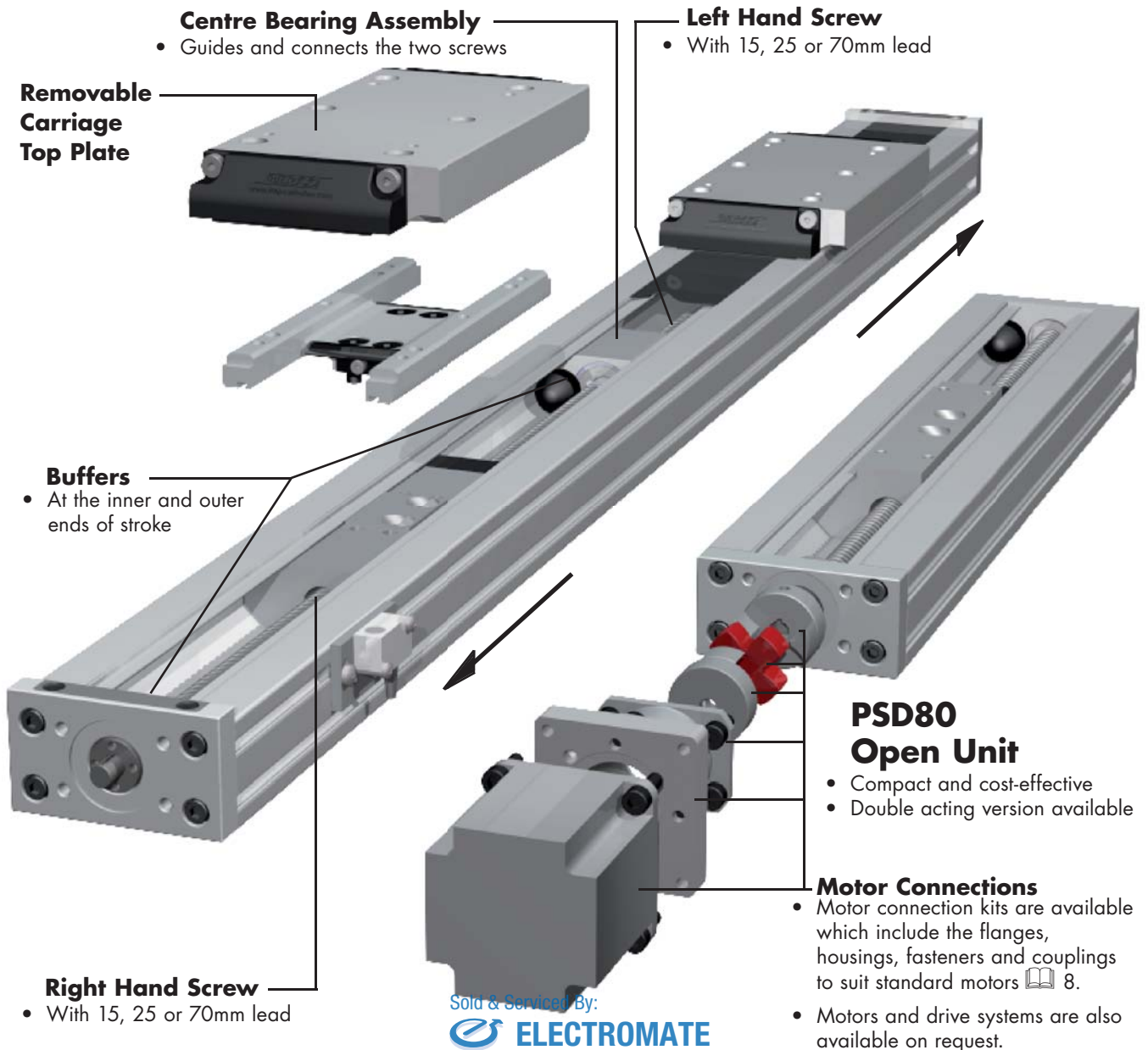

Sold & Serviced By:

 **ELECTROMATE**

Toll Free Phone (877) SERV098

Toll Free Fax (877) SERV099

www.electromate.com

sales@electromate.com

System Configurations and Applications

X-Y-Z Multi-Axis System

The Hepco PDU2 family of products can connect together to make multi-axis systems in a large range of configurations.

The example shown has a PDU2 X-axis, a PDU2M Y-axis and PSD80 Z-axis. It is typical of lightweight pick and place units. Each axis has differing requirements for load capacity, stiffness and gearing, and each of the units is perfectly suited for this duty.

Hepco will supply complete mechanical systems as shown including all axes, connectors and brackets, cable chains and trays, motor connections, drive shafts and frame elements.

On application, motors, drives, cables, electrical connectors and a turnkey service can be supplied.

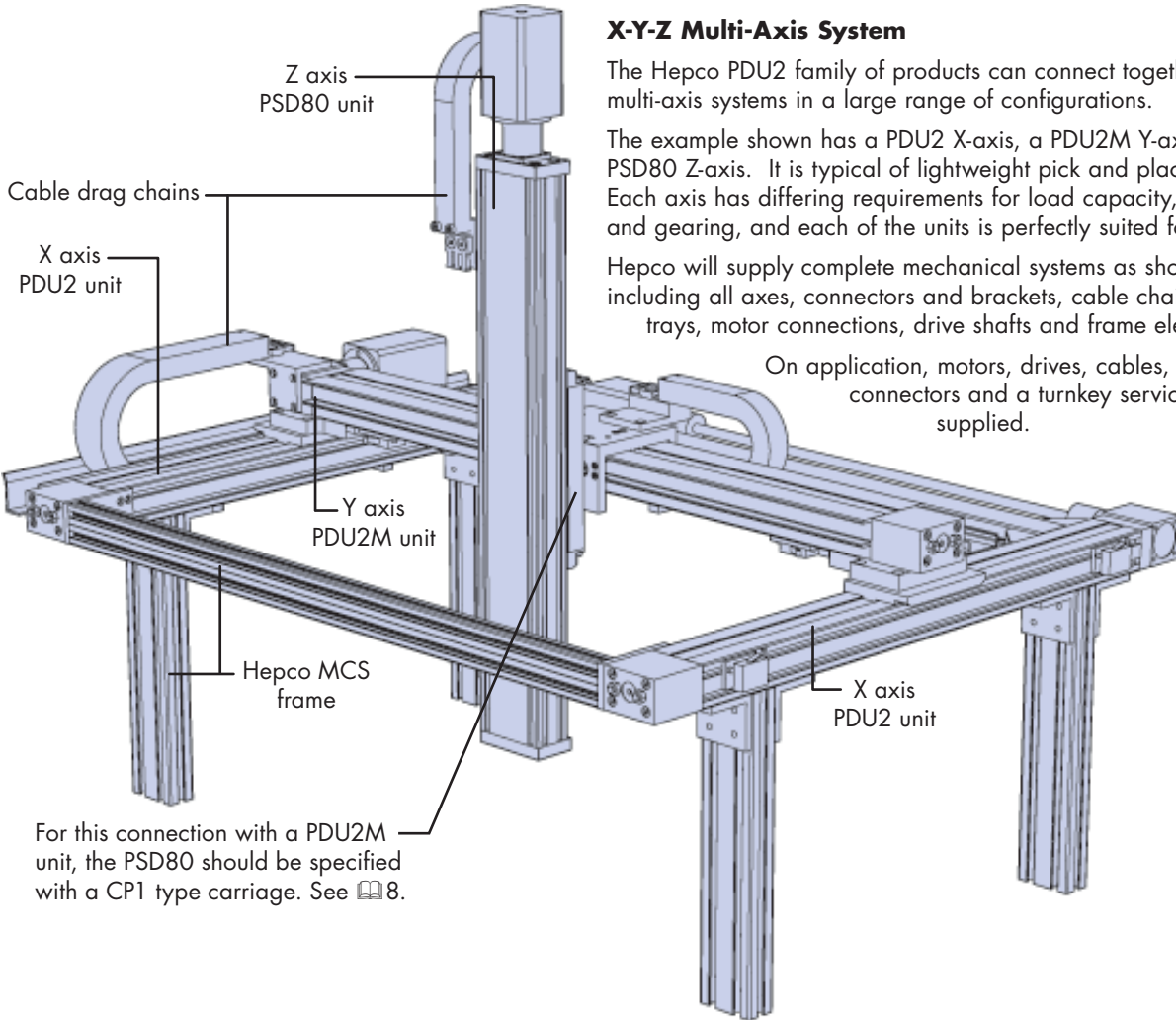

For this connection with a PDU2M unit, the PSD80 should be specified with a CP1 type carriage. See 8.

Centre Opening Hatch

A double acting PSD80 unit with two additional slave PSD80 units (two carriages move left and two right) is partnered with a parallel PSD80 slave unit with 4 carriages.

Two heavy hatch doors are each supported with a carriage at each corner.

A single motor without gearbox is sufficient to drive this centre-opening hatch arrangement, which is part of an automated processing line.

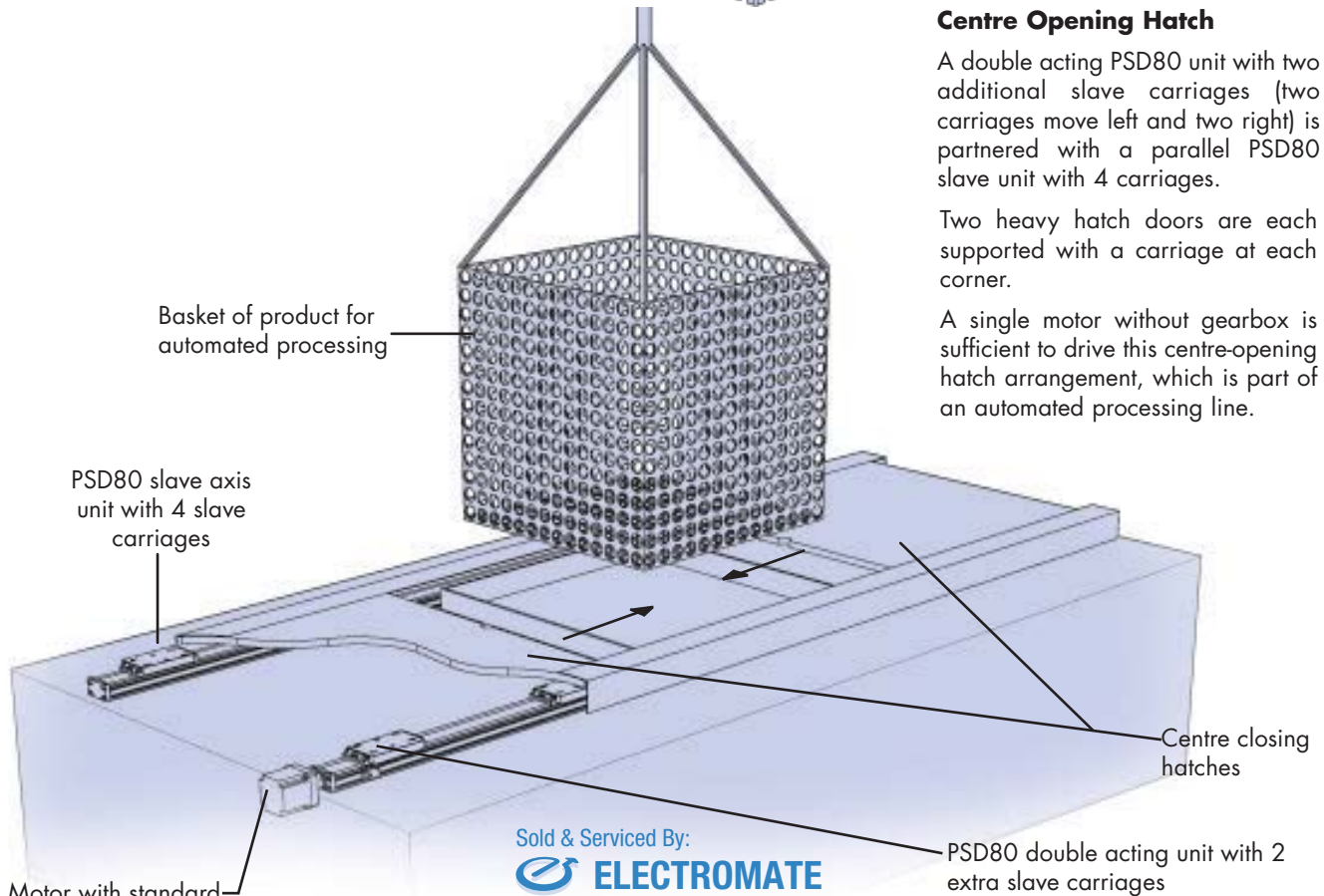

Sold & Serviced By:

ELECTROMATE

Toll Free Phone (877) SERV098

Toll Free Fax (877) SERV099

www.electromate.com

sales@electromate.com

System Configurations and Applications

X-Y Driven Table

Hepco PSD80 units can connect together in a number of useful X-Y configurations.

The example shown has a PSD80 open X-axis with extra slave carriage, and parallel to this is a PSD80 slave unit again with two carriages. These open units are mounted upside-down such that any debris from the environment will not accumulate in the channel and thus degrade performance. On top of these axes is a simple drilled connecting plate and on top of that is a similar arrangement of PSD80 open units for the Y-axes.

The use of open PSD80 units keeps costs down and reduces system height.

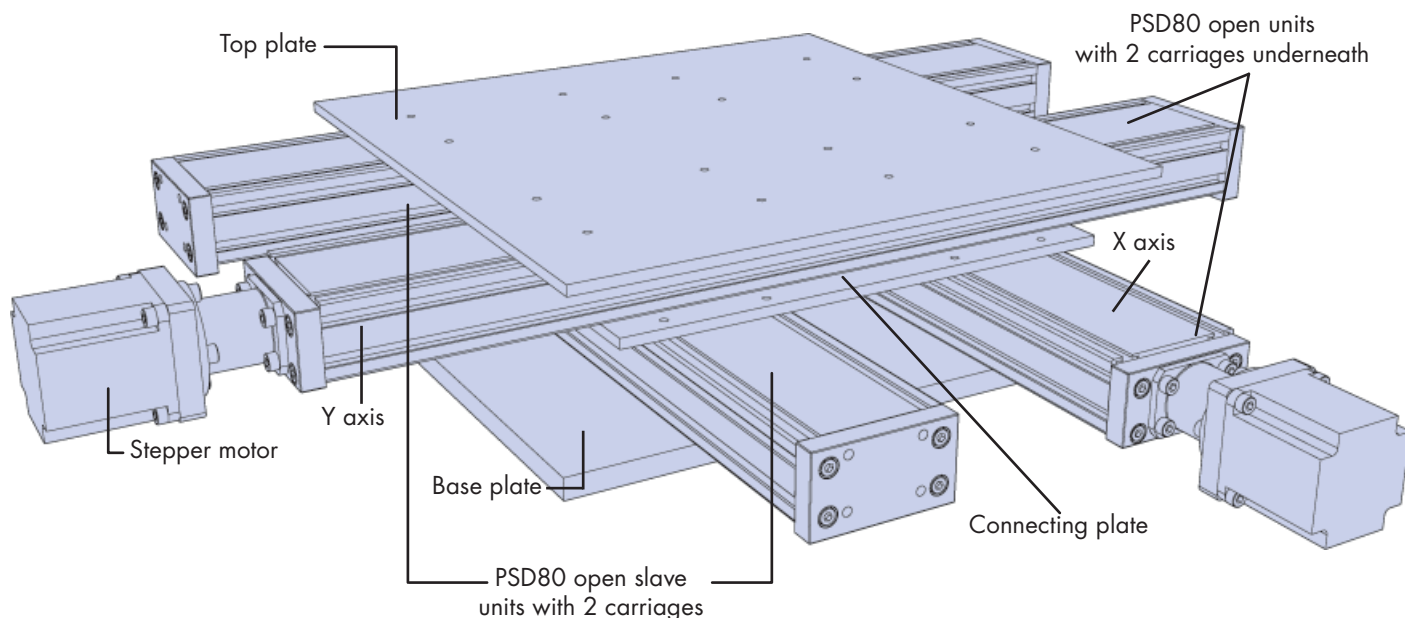

The above construction is suitable for a broad range of sizes, and a similar approach can also be used with closed PSD80 units. Hepco will specify and supply complete mechanical systems including all the plates above, plus motors and drives, on request.

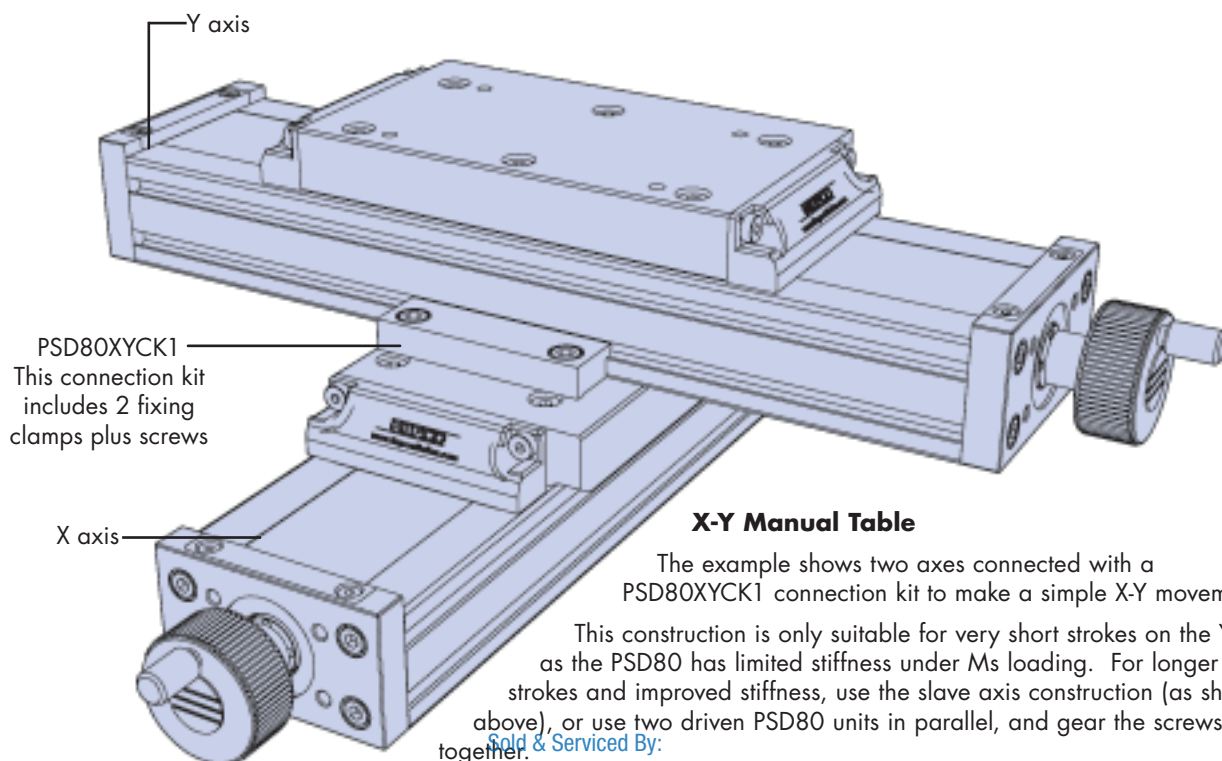

X-Y Manual Table

The example shows two axes connected with a PSD80XYCK1 connection kit to make a simple X-Y movement.

This construction is only suitable for very short strokes on the Y-axis as the PSD80 has limited stiffness under Ms loading. For longer strokes and improved stiffness, use the slave axis construction (as shown above), or use two driven PSD80 units in parallel, and gear the screws together.

Contact Hepco for a full specification and design service and for application advice.

ELECTROMATE
 Sold & Serviced By:
 Toll Free Phone (877) SERV098
 Toll Free Fax (877) SERV099
www.electromate.com
sales@electromate.com

Data & Dimensions - Closed Units

PSD80 Closed Slave Unit



Screw Driven PSD80 Closed Unit

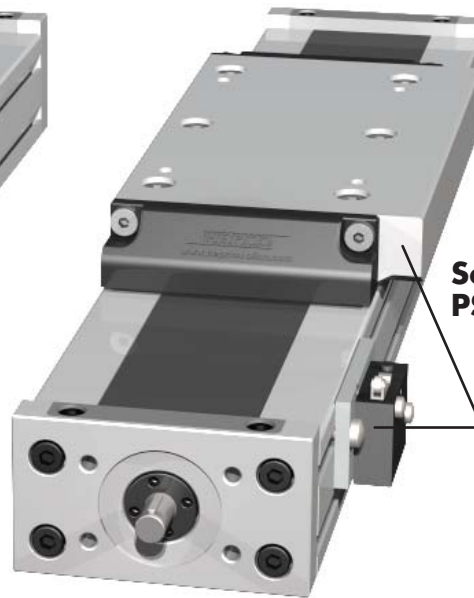

The position of the switches and the switch cam on the carriage are easily reversed left to right.

The main dimensions of the PSD80 closed unit are shown in the drawing below. Further details can be obtained from the 2D and 3D CAD files, available from

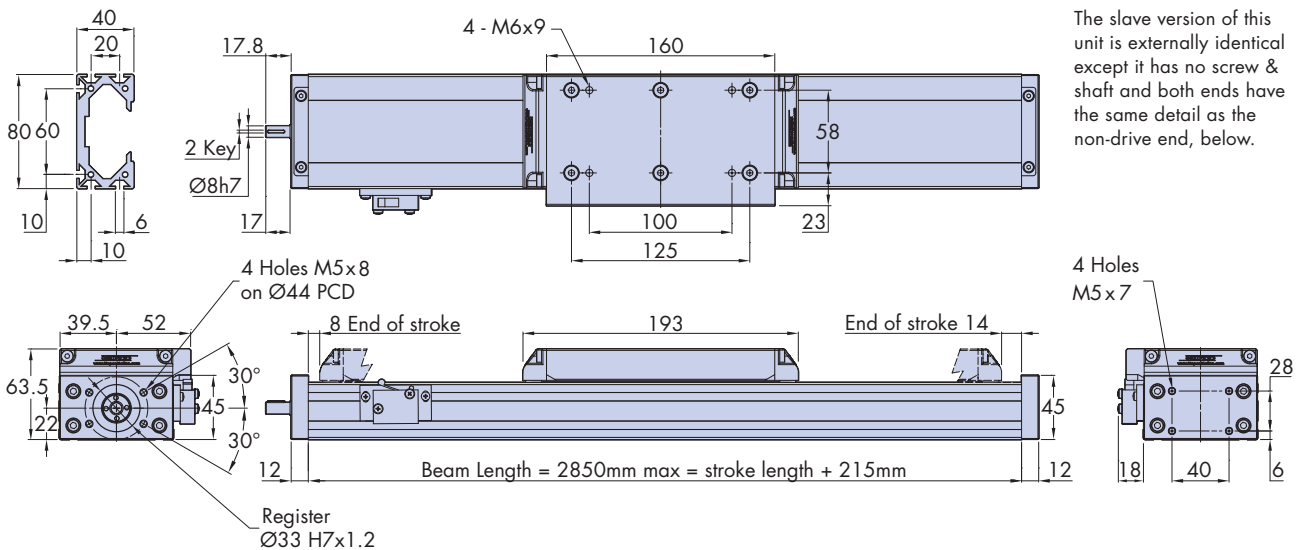

PSD80 closed units are covered by a stainless steel band with contacting seals on the ends and sides of the carriage. This arrangement provides good protection for the unit's moving parts against ingress of debris.

The above drawing shows a unit with a single carriage, but it is also possible to specify units (closed, open and double-acting) with one or more additional carriages. The usual arrangement for such systems is for just one carriage to have a drive nut, but it is also possible (on request) to offer units in which multiple carriages are driven by the same screw. For closed units with more than one carriage, the carriage centres should be separated by at least 270mm to allow the cover to function correctly. Contact Hepco's Technical Department for full details.

The length of screw driven PSD80 units is limited by the available screw length. Units with beams up to 2850mm long can be made, but in many cases the performance of the screw (due to whipping & buckling) will limit the practicable length to between 1 and 1.5m. These aspects of performance are calculated 10. If units have additional carriages, then it is possible to increase the unit length before encountering dynamic problems. Contact Hepco for details.

Slave units may be ordered with beam lengths up to 6m in one piece. Slave units are normally supplied with a fitted nut so that the stroke length and buffer positions match driven units of the same length. This nut can be deleted if not required 8.

Both driven and slave units have internal buffers. It is usual practice with driven systems to stop motion some distance before the buffers are contacted.

Sold & Serviced By:



Toll Free Phone (877) SERV098

Toll Free Fax (877) SERV099

www.electromate.com

sales@electromate.com

Data & Dimensions - Open Units

PSD80 Open Slave Unit



Screw Driven PSD80 Open Unit



The main dimensions of the PSD80 open unit are shown in the drawing below. Further details can be obtained from the 2D and 3D CAD files, available from

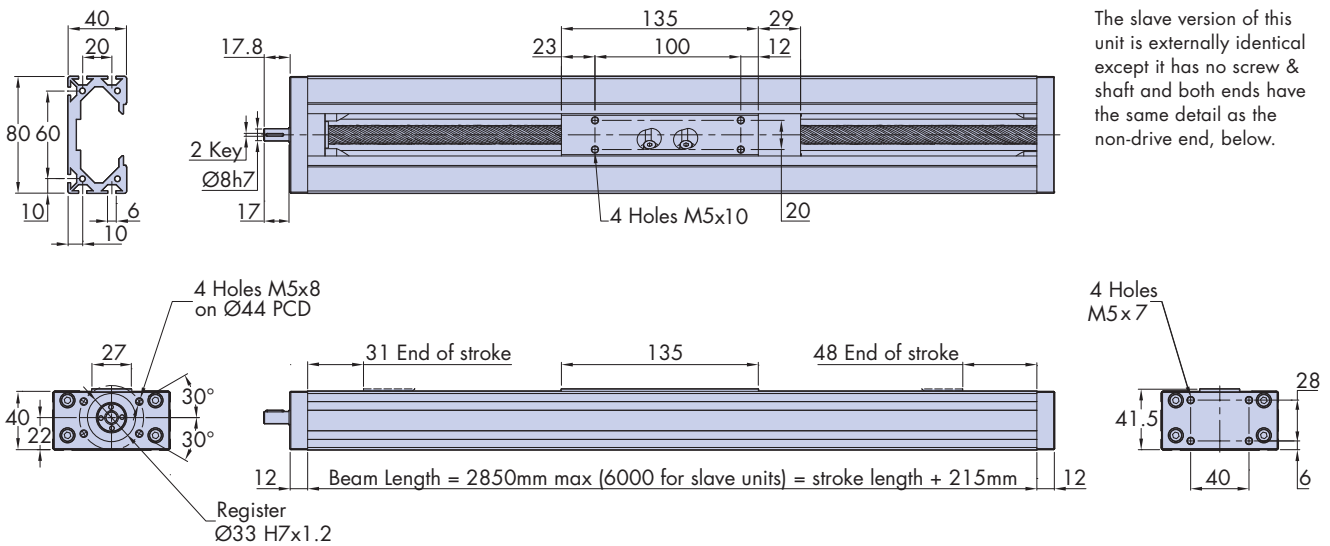

PSD80 open units are very compact, being two thirds the height of the covered type. They benefit from lower friction due to the elimination of the seal contact, and are substantially lower in cost and weight due to the reduction in the number of parts.

Herculane wheels can be sensitive to particles of debris which could fall into and accumulate in the beam channel, and so it is recommended that PSD80 open units are used in clean environments, or are configured to avoid any debris getting in (for example by arranging the units upside down  4).

PSD80 units may be specified with a broad range of thread leads: 4, 15, 25 & 70mm with the 15, 25 & 70 also being available with a left hand thread. The screws are made from stainless steel, and run with ultra-smooth, durable polymer nuts. This broad range of threads allows for a very wide range of speeds up to 1m/s. See  10 for full details of screw performance.

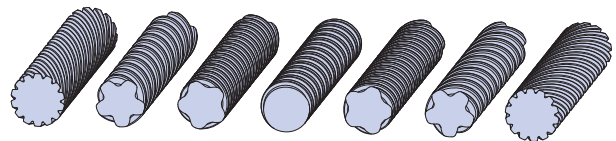

Wide range of screw pitches

All types of PSD80 unit may be ordered with the corrosion resistant option. For these versions, in addition to all external aluminium components being anodised, all the steel parts are made from stainless steel. This includes bearings and fasteners as well as the main screw.

Sold & Serviced By:



Toll Free Phone (877) SERV098

Toll Free Fax (877) SERV099

www.electromate.com

sales@electromate.com

Data & Dimensions - Double Acting Units

PSD80 Double Acting Closed Unit

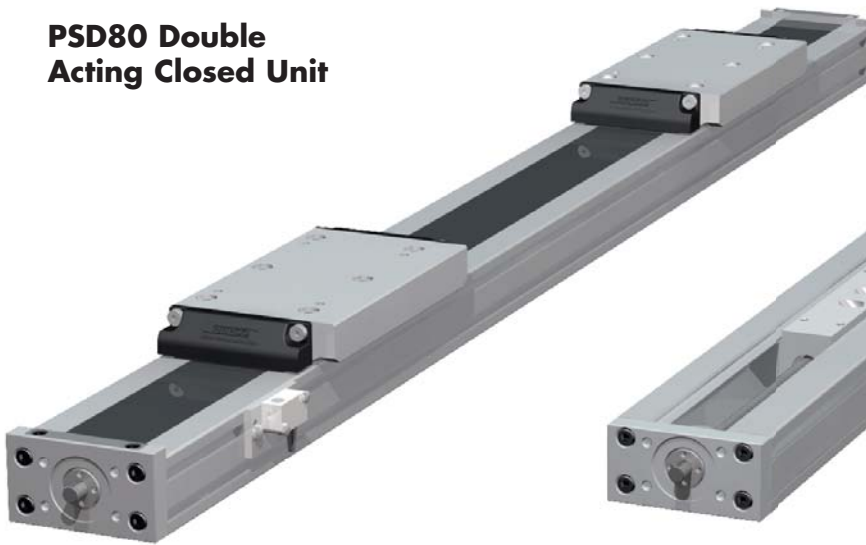

PSD80 Double Acting Open Unit

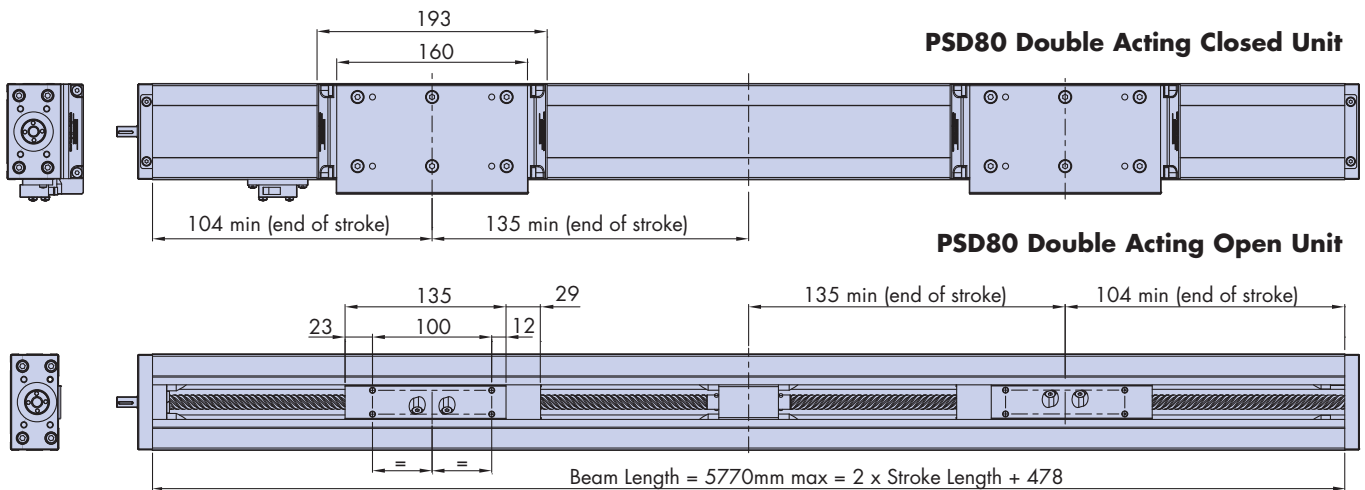

All other dimensions of double acting PSD80 units are the same as the units shown 5 & 6.

PSD80 double acting units have two (or more) carriages whose movements are symmetrical about the middle of the beam, this motion being achieved by using linked left and right hand threaded screws. The units may be ordered with 15, 25 and 70mm screw leads.

They share the same major parts, and have the same benefits as other PSD80 units, and are available in both closed and open formats, as well as in a corrosion resistant version.

The units shown above just have two carriages, but it is common to have additional slave carriages, particularly if the items to be moved are large (see application example 3).

PSD80 double acting units are suitable in numerous applications including mechanical handling, automation and as an actuator for sliding doors (see application example 3). All the screws and nuts have low friction and those with a large helix angle (particularly pitches 25 and 70mm) are easily back driven. This means that in the event of an electrical failure, the carriages can be moved by hand (subject to the type of drive).

Units can be made with beams up to 5770mm long, but in many cases the performance of the screw (due to whipping & buckling) will limit the practicable length to between 2 and 3m. These aspects of performance are calculated 10. For units which have additional carriages, it is possible to extend the length of the beams while still avoiding dynamic problems with the screws. Please contact Hepco for full details.

PSD80 units have a beam profile with 6mm wide T-slots which are compatible with profiles, T-nuts, covers and brackets from the HepcoMotion MCS aluminium frame construction system. The same T-slot size and spacing is also used on companion products PDU2 and PDU2M.

Sold & Serviced By:



Toll Free Phone (877) SERV098

Toll Free Fax (877) SERV099

www.electromate.com

sales@electromate.com

How To Order

This ordering information is given to assist communication, but we recommend that you discuss the application with Hepco first so that we can help to specify the best unit for your needs.

Main Unit

PSD80 L1246 T C D 25 (CP1) (C)

Product range = **PSD80**

L1246 = beam length in mm (max 2850 for standard, 5770 for double acting and 6000 for slave units).

T = beam with T-slots (this is the only option at present).

Unit configuration: **C** = Closed; **P** = Open.

Drive type: **D** = Driven; **DA** = Double acting; **S** = Slave; **SW** = Slave without nut.

25 = Screw lead in mm. Choose from 4, 15, 25 & 70 and also L15, L25 & L70 (left hand threads). If a ballscrew is required, please contact Hepco

CP1 = Special carriage for Y-Z connection to PDU2M - see  3. Leave blank for the standard version.

C = Corrosion resistant version. Leave blank for the standard version.

Additional Carriages

PSD80 AC (C) (N)

AC = Additional closed carriage; **AP** = Additional open carriage

C = Corrosion resistant version. Leave blank for the standard version.

N = Additional carriage requires a nut. Leave blank for no nut required.

To specify additional slave carriage(s) on a PSD80 unit, simply put the quantity and the relevant part number on the order after the part number for the main PSD80 unit, and state where the carriages should be fitted (i.e. at the driven or non-driven end. If the N option is specified, then the carriage spacing centre distances must also be stated).

Ancillary Components

Limit switch assembly (includes switch, bracket & fixings) = PDU2-V3SWA-M (mechanical), PDU2-V3SWA-I (inductive).

T-nuts: M3 = 1-242-1022; M4 = 1-242-1023.

T-slot cover (supplied fitted in each of the T-slots) = 1-242-1037.

Motor Connection Kits

These include the flange tube, motor flange, coupling components and all fasteners required to connect the customer's motor to a PSD80 unit.

The following standard kits are available from stock:

PSD80MCK-NEMA23 Suits 23 frame stepper motors

PSD80MCK-NEMA34 Suits 34 frame stepper motors

PSD80MCK-IEC56 Suits 56 frame induction motors

PSD80MCK-IEC63 Suits 63 frame induction motors

PSD80MCK-IEC71 Suits 71 frame induction motors

When ordering these motor kits please state the motor shaft diameter, length and key details, as these may vary between manufacturers.

Hepco will make flanges to fit any motor type, on request.

Hepco will supply units with fitted motors and drives on request.

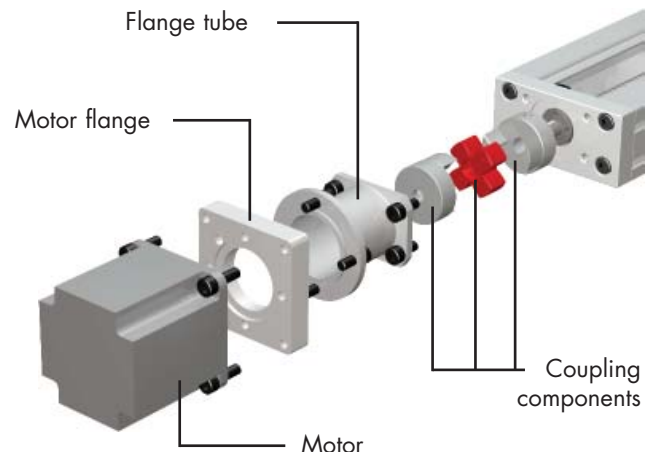

Sold by:  **ELECTROMATE**

Toll Free Phone (877) SERV098

Toll Free Fax (877) SERV099

www.electromate.com

sales@electromate.com

Calculations & Performance

Carriage Service Interval Calculation

After very long service, slight play in the carriage may develop due to wheel wear. This can be corrected by re-adjusting the carriage, which will return the unit to its original condition. Adjustment is quick and simple and may be repeated several times.

The table shows the maximum carriage loading, and the calculation below determines the service interval.

Note that the life of the nut should also be considered as this may be the determining factor (see  10).

Hepco will provide more data and calculations for your application, on request.

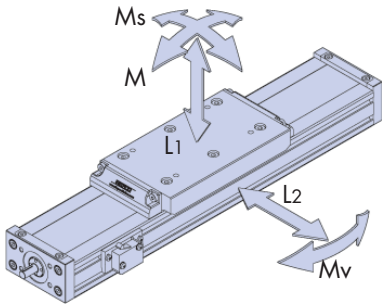

Carriage Load Capacity				
L1	L2	Ms	Mv	M
500N	500N	7.5Nm	14Nm	14Nm

To determine service interval, first calculate the load factor LF using the equation below.

$$LF = \frac{L1}{L1_{(max)}} + \frac{L2}{L2_{(max)}} + \frac{Ms}{Ms_{(max)}} + \frac{Mv}{Mv_{(max)}} + \frac{M}{M_{(max)}} \leq 1$$

$$\text{Service Interval (km)} = \frac{5000}{(0.25 + 0.75 \times LF)} \quad \text{Note: life will be several times this service interval}$$

PSD Unit Weights (kg)							
Standard Units (1 carriage)		Slave Units (1 carriage)		Double Acting Units (2 carriages)		Carriage Weights	
Closed	Open	Closed	Open	Closed	Open	Closed	Open
3.5 x L + 1.5	3.4 x L + 0.82	2.9 x L + 1.3	2.8 x L + 0.63	3.5 x L + 2.8	3.4 x L + 1.5	1.1	0.5

The weight of a unit is calculated using the formulae in the table above, where L is the beam length in m. For units with extra carriages, add the weight per carriage shown in the table above. This data will also allow the calculation of the mass of the moving parts.

Drive Data & Calculations

The linear force which can be generated by a PSD80 unit is determined by the torque applied (T in Nm), the force coefficient (Cf) and composite drag (Dc) of the PSD80 unit.

PSD80 Force Coefficient Cf				
Screw Lead /mm	4	15	25	70
Force Coefficient Cf	660	260	180	53

PSD80 Composite Drag Dc	
Open Units	5+5xLF
Closed Units	10+5xLF

$$\text{Linear Force (N)} = Cf \times T - Dc$$

The above equation gives the linear force developed by a typical system in typical conditions, but there will be some variation. It is recommended to select motors which have significantly more than the minimum torque, to ensure performance and reliability.

Applications in which the applied load is in the opposite direction (i.e. when the load is trying to back-drive the unit) will demand less torque. Please contact Hepco for calculation assistance in these cases.

Beam Deflection Calculations & Data

The deflection of a PSD80 under load follows conventional beam calculations.

For example, the deflection of a PSD80 unit L (mm) long, simply supported at the ends and subject to a central load F (N) is:

$$\text{Deflection (mm)} = \frac{F \times L^3}{48 \times E \times I}$$

Where E is the young's modulus of aluminium alloy (= $7 \times 10^4 \text{ N/mm}^2$) and I is the second moment of area of the PSD80 beam section (= $2.0 \times 10^5 \text{ mm}^4$ for L1 loading direction and $7.8 \times 10^5 \text{ mm}^4$ for L2 loading direction).

Example: in the case of a simply supported PSD80 beam of 1000mm between supports, and subject to a central L1 loading of 150N, the deflection at the centre of the span will be 0.22mm.



Toll Free Phone (877) SERV098
Toll Free Fax (877) SERV099
www.electromate.com
sales@electromate.com

Calculations & Performance

Thrust Load Performance

The amount of thrust which a PSD80 unit can produce depends upon the screw lead, the speed, and the life required.

As the screw turns faster, the nut's ability to transmit load reduces: For very light loads and occasional rapid movements, shaft speeds of up to 1000rpm are possible, but for sustained loads and higher thrusts it is best to operate at below 600 rpm.

Conversely, it is possible to generate substantial thrust loads on an occasional basis and when the speeds are low.

The table below gives an indication of typical loadings, but please contact Hepco for advice on suitability for your duty.

Contact Hepco for details of the performance of units with the optional ballscrew drive.

	Static Thrust Load Capacity	Thrust Load Capacity for occasional, slow speed use	Thrust Load Capacity for typical applications
4mm lead	>500N	300N	100N
15mm lead	>500N	280N	90N
25mm lead	>500N	300N	100N
70mm lead	>500N	210N	70N

Rotary - Linear Speed Equivalence

Motor Speed rpm	100				200				400				600			
Screw Lead mm	4	15	25	70	4	15	25	70	4	15	25	70	4	15	25	70
Linear Speed m/s	0.007	0.025	0.042	0.117	0.013	0.050	0.083	0.233	0.027	0.1	0.167	0.467	0.04	0.15	0.25	0.7

Screw Critical Speed

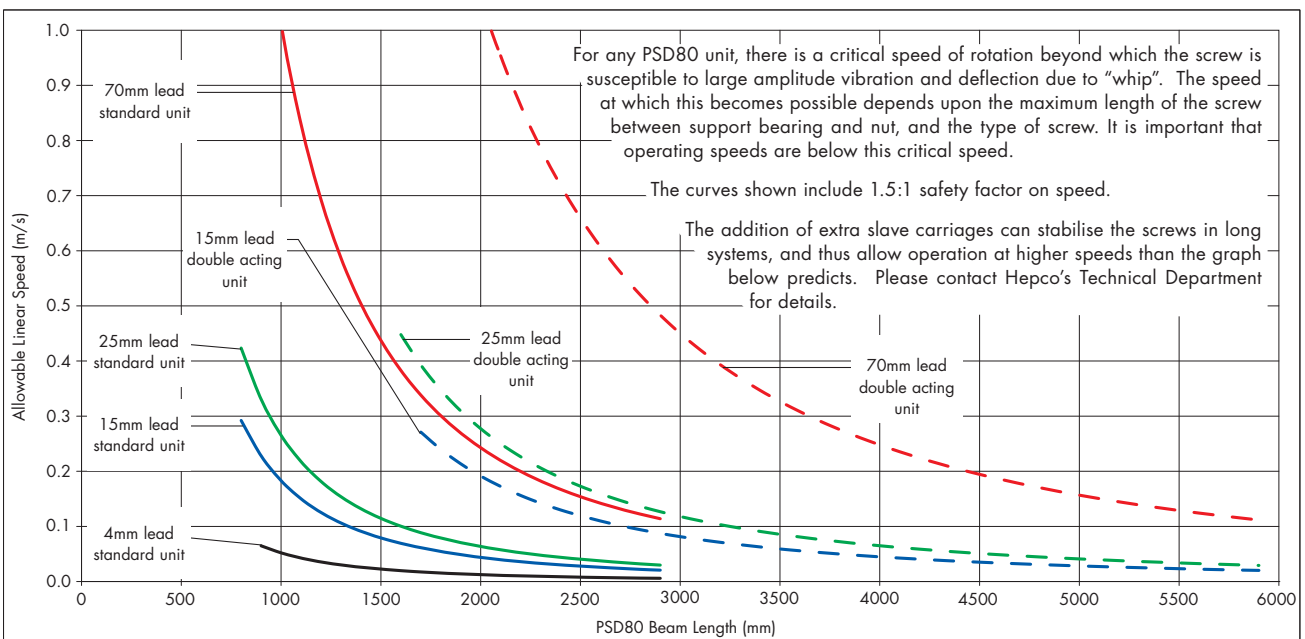

Screw Buckling Load

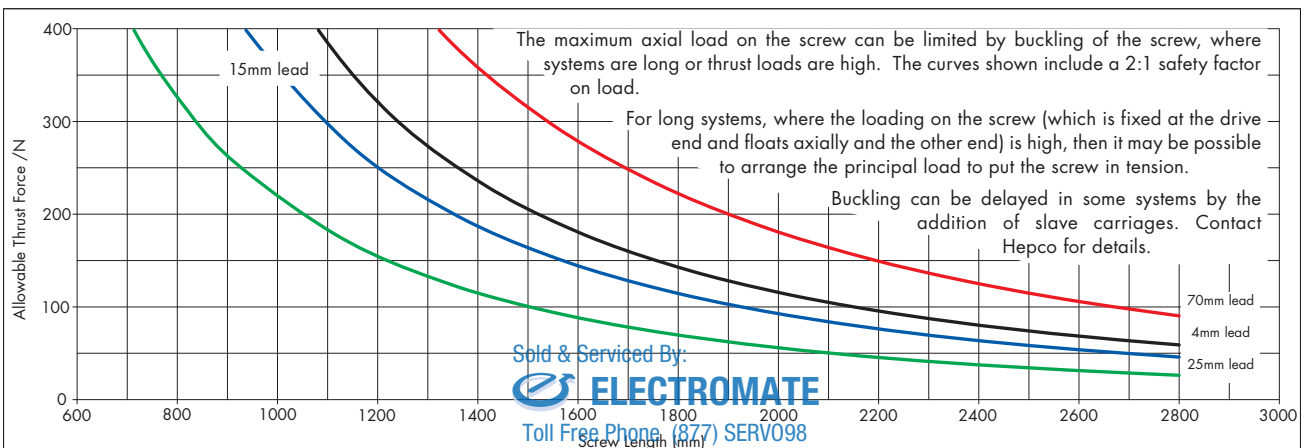

Sold & Serviced By:
ELECTROMATE
 Toll Free Phone (877) SERV098
 Toll Free Fax (877) SERV099
www.electromate.com
sales@electromate.com

HepcoMotion® Product Range



GV3
Linear Guidance and
Transmission System



HDS2
Heavy Duty
Slide System

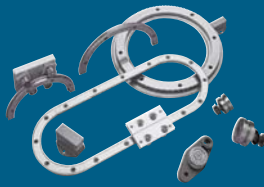

PRT
Ring Slides and
Track System



HDRT
Heavy Duty Ring Slides
and Track System



SL2
Stainless Steel Based
Slide System



LBG
Linear Ball Guides

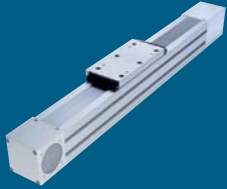

SBD
Sealed Belt
Drive

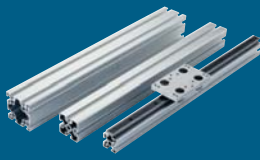

MCS
Aluminium Frame
and Machine
Construction System

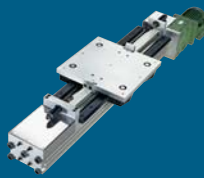

HDLS
Heavy Duty Driven
Linear System



DLS
Linear Transmission and
Positioning System

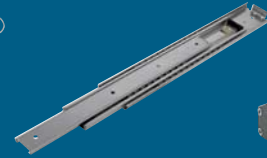

HTS
Telescopic Ball
Bearing Slides



HPS
Powerslide-2 Guided
Rodless Cylinder



MHD
Heavy Duty Track Roller
Guidance System

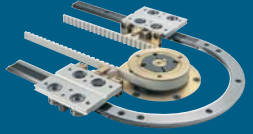

DTS
Driven Track System



BSP
Ballscrew Premier

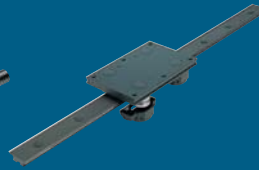

Simple Select®
Vee Slide Linear
Guidance Systems

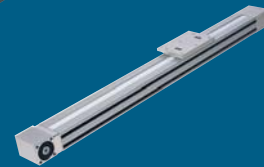

PDU2
Profile Driven Unit

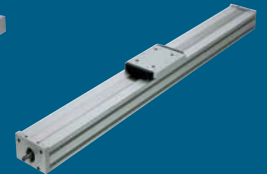

PSD120
Profile Screw Driven Unit

Bishop-Wisecarver Product Range

HepcoMotion® – Exclusive European partners and distributors for Bishop-Wisecarver since 1984.

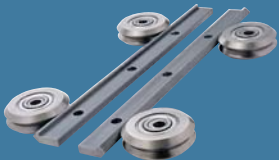

DUAL VEE®
Single Edge Slide System

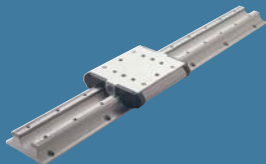

LoPro®
Aluminium Based
Slide System

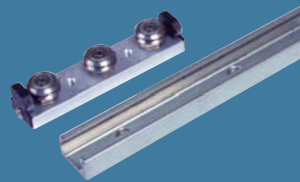

UtiliTrak®
Lightweight U Channel
Guideway

For further information on HepcoMotion® products –
please request our leaflet 'FPL'

HEPCO®

Sold & Serviced By:

ELECTROMATE

Toll Free Phone (877) SERV098

Toll Free Fax (877) SERV099

www.electromate.com

sales@electromate.com



INVESTOR IN PEOPLE

