

Rotary Motion Drives Chairside Dentistry System

Unique polar motion system reduces cost, improves performance.

Most of us don't like to think about dental crowns. Odds are, however, that you will need one at some point in your life. Fortunately, this type of dental restoration is getting faster and easier for the patient, thanks to an emerging class of digital dentistry systems.

Think of these systems as rapid manufacturing cells that operate within the dentist's office. The cells typically consist of an imaging system that takes a digital impression of the damaged tooth and a "chairside" milling machine that makes a ceramic crown. Customized, dentist-friendly CAD/CAM software allows the two pieces of hardware to work together—translating the imaging data into machine tool code.

One of the main benefits of these systems is the time saved by eliminating the need for a dental lab to manufacture the crown. With a traditional restoration, many days can elapse between the physical impression to crown insertion. The digital crown procedure can take place within a single day, often in only a couple hours.



For all the promise of same-day crowns, the capital cost of digital dentistry systems has limited their adoption somewhat—but not for long. A new digital dentistry solution from IOS Technologies Inc. drastically reduces system cost without sacrificing performance.

A division of Glidewell Dental Laboratories, IOS has developed its chairside digital dentistry solution around three subsystems:

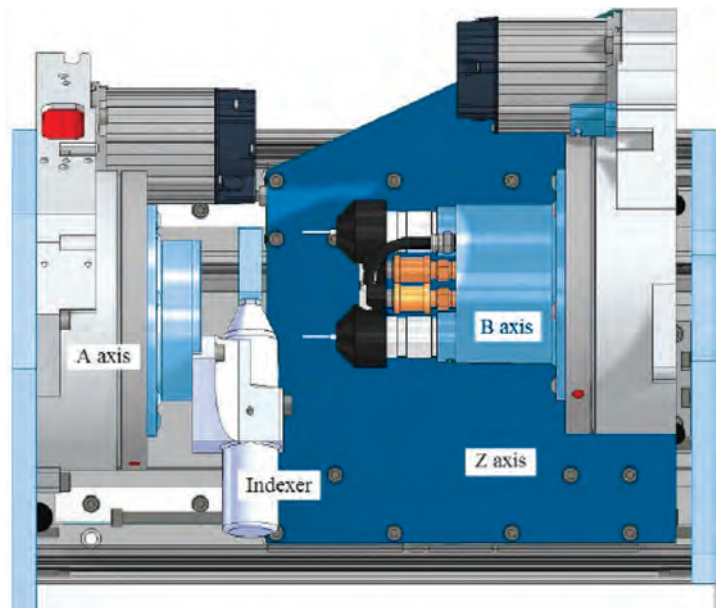

CASE STUDY



While developed specifically for IOS dental milling machine, the polar motion system based on ServoBelt Rotary has implications for other types of precision micro-machining centers since it addresses fundamental problems of chatter, dynamic stiffness and positioning accuracy. We see it as a good fit for small-scale subtractive prototyping applications.

- FastScan® intraoral scanner, a compact 3D imaging device that can produce high-resolution digital impressions that are several times more accurate than a traditional impression.
- FastDesign™ CAD software guides the dentist through the scanning process and proposes the ideal custom restoration, then generates CAM instructions.
- TS150™ in-office milling system.

All three of these subsystems feature technical breakthroughs that improve the cost-to-performance ratio of chairside dentistry. However, any engineer interested in motion control or machine tool design should take a close look at the TS150 mill in particular.

Rather than the Cartesian motion system you might expect on a milling machine, the TS150 is based on a rotary motion and uses polar positioning coordinates. This non-intuitive approach to motion allows the system to achieve the precision and accuracy of digital dentistry systems costing 40% more. The polar motion system also offers design lessons that can be applied to non-dental applications such as CNC micro-machining and subtractive prototyping (see sidebar).

A counter-intuitive motion system. For the vast majority of 3-axis milling machines, regardless of their application, a Cartesian motion system is a given. Linear X and Y axes position a cutting tool, which translates to the workpiece on a Z axis.

IOS's chairside mill takes a very different approach. Its motion system employs a pair of Bell-Everman ServoBelt Rotary stages, installed vertically and facing one another. One stage, the A axis, positions the workpiece, a ceramic blank that is machined into the finished crown. The other stage, the B axis, positions an air spindle with the cutting tool. The B-axis stage with the cutting tool also translates axially toward the A-axis stage on a short-travel Bell-Everman ServoNut linear drive, which forms the Z axis. The motion system finally features a small indexing work holder that can rotate the blank 180 degrees about its vertical axis during the machine process, so that it can be machined on two sides.

By carefully controlling the rotation of the two stages relative to one another as well as their axial position, the cutting tool can be delivered to any point on the workpiece surface. That may sound simple enough, but the positioning algorithms required the use of a polar coordinate system.

Polar coordinates, while familiar to most motion engineers, did create some control challenges. Because the IOS scanner and software packages the 3D imaging data as an STL file, the system references points on the crown surface in Cartesian space. So the controller has to make a real-time transformation into polar coordinates to generate a suitable tool path for the rotary stages. After looking at many off-the-shelf motion controllers, we found that only the Delta Tau Turbo PMAC offered the necessary support for polar kinematics as well as the processing power to handle the coordinate system transformations in real time.

Even then, the controls development took months, in part because the mill ultimately has to work with a simplified HMI that's optimized for programming by dentists rather than machine tool operators versed in G-Code. By intent, the user has no visibility in the workings of the machine tool code. That complicated the software development on IOS's end and made the control interface work on Bell-Everman's end that much more difficult.

CASE STUDY

Why go rotary? If Cartesian motion was the obvious choice for the dental mill, it was not the best. Early in the process, the engineering teams at IOS and Bell-Everman rejected traditional linear motion and went down the rotary path. While certainly not the easiest way to go from an engineering standpoint, the use of rotary stages resulted in design benefits too powerful to ignore:

- **Eliminate bearing rumble.** The belt-driven ServoBelt rotary stages eliminate the bearing rumble that can affect linear motion devices based on recirculating balls or other rolling elements. This problem can be an issue in any application requiring smooth motion, but with the dental mill, rumble was a deal breaker since it can read through to the surface finish of the crown.
- **Improve stiffness.** The rotary stages each contain beefy, 6-inch-diameter duplex angular contact bearings that are far stiffer than the linear bearings that would have been used in a Cartesian system with the same envelope. By using rotary bearing with high dynamic stiffness, the milling machine resists chatter even at very fast feed rates and spindle speeds as fast as 150,000 rpm.
- **Easy to seal.** Machining ceramic crowns requires liberal amounts of cutting fluid, so the entire work area was sealed. And, having just two rotary stages at opposing ends of the work area proved easier to seal than an equivalent 3-axis linear motion system. Just two simple seals, one for the A axis and one for the B axis, sealed off the entire motion system.

Great Cost-to-Performance Ratio. And perhaps the most important reason to go rotary has to do with cost. At first glance, rotary stages don't always have a lower price tag than linear systems. But to get an equivalent quality of motion in this application—in terms of speed, smoothness and accuracy—you would have to pay for top-shelf linear motion products. What's more, the ease of sealing the rotary stages also drove down overall cost substantially.

Add in IOS engineering's much broader cost reduction efforts, which went beyond the motion system to include every subsystem of the machine, and the new chairside digital dentistry system sets a new benchmark for price and performance.

The TS150 sells for about 40% less than comparable machines, yet the mill sacrifices nothing in terms of performance or throughput. It can finish a crown in about 15 minutes.

What's more, when used in conjunction with IOS FastScan and FastDesign software, the mill can hold tolerances within 30 μm . Typical tolerances in the industry are 50 μm , but the additional accuracy delivered by the chairside dental mill improves the fit of the crown.

Prior to the launch of the complete chairside system, the TS150 was thoroughly evaluated within Glidewell's own dental laboratories, which are the largest and most technically advanced in the world. The system produced thousands of crowns to date with hundreds of satisfied dentists. And it continues to mill crowns each and every day.

ServoBelt Rotary

