

V Series Servo Motor

QUICKLINK: vseries

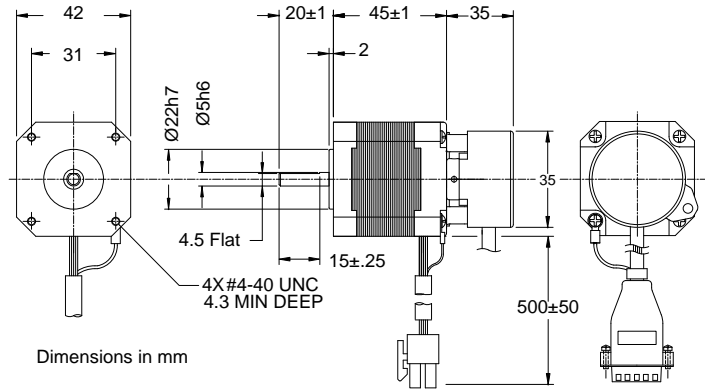
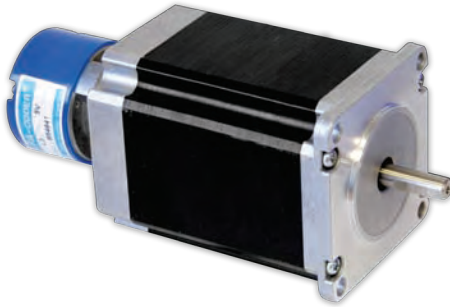

Dimensions in mm

- 1) ratings are at 40°C with aluminum mounting plate 305mm x 305mm x 12mm
- 2) Motors offered as standard with 2048 line incremental encoder - call for other options
- 3) see page 104 for explanation of E.D.C.M.
- 4) Full CAD drawings are available on our website.

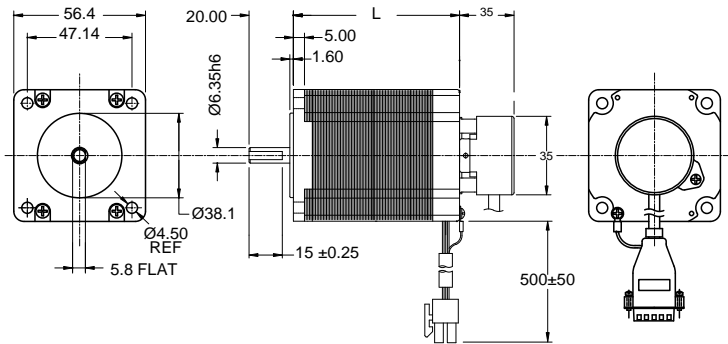

		NEMA 17		NEMA 23	
MODEL		V0050-214-A-000	V0100-214-B-000	V0200-214-B-000	V0250-214-B-000
LENGHT "L"	MM	45	52	78	104
RATED OUTPUT (PR)	W	50	100	200	200
POWER SUPPLY	V	48	48	48	48
RATED TORQUE (TR)	N.M	0.095	0.19	0.38	0.57
	LB.IN	0.84	1.68	3.36	5.0
PEAK TORQUE (TP)	N.M	0.29	0.57	1.15	1.72
	LB.IN	2.56	5.0	10.17	15.22
RATED SPEED	R/MIN	5000	5000	5000	3350
MAXIMUM SPEED	R/MIN	7320	7320	5900	4000
RATED ARMATURE CURRENT	A RMS	5.3	6.3	5.7	5.8
PEAK ARMATURE CURRENT	A RMS	15.2	17.7	16.5	17
TORQUE CONSTANT OF E.D.C.M	N.M/A ^{+/-10%}	0.019	0.03	0.07	0.1
	LB.IN/A	0.168	0.27	0.619	0.88
VOLTAGE CONSTANT OF E.D.C.M	V/(KR/MIN) ^{+/-10%}	2.00	3.5	7.4	10.7
ARMATURE RESISTANCE OF E.D.C.M	OHM ^{+/-10%}	0.45	0.45	0.6	0.89
ARMATURE INDUCTANCE OF E.D.C.M	MH ^{+/-30%}	0.8	1.6	3.0	4.2
ROTOR MOMENT OF INERTIA	KGM ² X10 ⁻⁴	0.039	0.103	0.192	0.27
	GM.CM ²	39	103	192	270
	OZ-IN-SEC ²	0.55x10 ⁻³	1.5x10 ⁻³	2.71x10 ⁻³	3.82x10 ⁻³
MAXIMUM RADIAL SHAFT LOAD	N	39.2		58.8	
	LBF	8.8		13.2	
MAXIMUM SHAFT THRUST LOAD	N	19.6		29.4	
	LBF	0.6		0.8	
MASS	KG LB	0.65 1.43	0.9 2.00	1.35 2.97	1.7 3.74

Holding Brake Specifications

MOTOR POWER MOTOR FRAME SIZE		30W NEMA 17 40 MM	50W NEMA 17 40 MM	100W NEMA 17 40 MM	100W NEMA 23 60 MM	200W NEMA 23 60 MM	400W NEMA 23 60 MM	200W NEMA 34 80 MM	400W NEMA 34 80 MM	600W NEMA 34 80 MM	750W NEMA 34 80 MM
RATED VOLTAGE	V	24									
STATIC FRICTION TORQUE	Nm	0.32			1.27			2.55			
	lb-in	2.83			11.24			22.5			
INPUT POWER	W	5		9	9		9.5		9.5		
INPUT CURRENT	A	0.2		0.375	0.375		0.39		0.39		
ARMATURE RELEASE TIME	ms Max	20		20	20		50		50		
ARMATURE PULL IN TME	ms Max	40		40	50		80		80		

Motor Phase Excitation Sequence

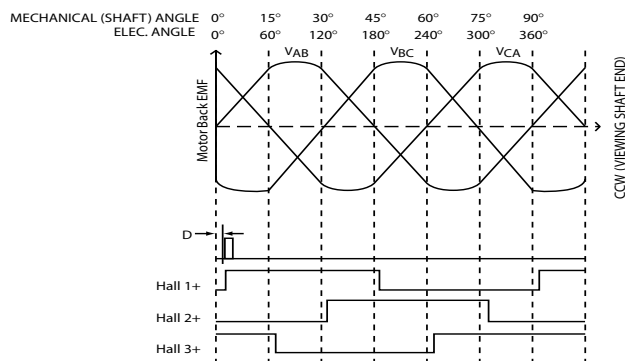

SHAFT LOCK

Motor shaft can be locked at 0° by applying the rated current + to terminal B and - to terminal A.

Encoder resolution 2,000 lines/rev.

Encoder Connections

ENCODER CONNECTION

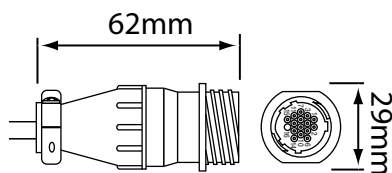

	CONNECTOR	MATING CONNECTOR
HOUSING	AMP# 206036-3	AMP# 206037-1
PINS	AMP# 1-66103-2 (15 pcs)	AMP# 1-66105-3 (15 pcs)
CABLE CLAMP	AMP# 206070-1	AMP# 206070-1

PIN NUMBER	FUNCTION	COLOR
1	A+	Blue
2	A-	Blue/black
3	B+	Green
4	B-	Green/black
5	Index Z+	Yellow
6	Index Z-	Yellow/black
7	Hall 1+	Brown
8	Hall 1-	Brown/black
9	Hall 2+	Grey
10	Hall 2-	Grey/black
11	Hall 3+	White
12	Hall 3-	White/black
13	+5V	Red
14	0V	Black
15	DRAIN	W/shrinktubing
16	N/C	N/c

Motor Connections

MOTOR WITHOUT BRAKE CONNECTION

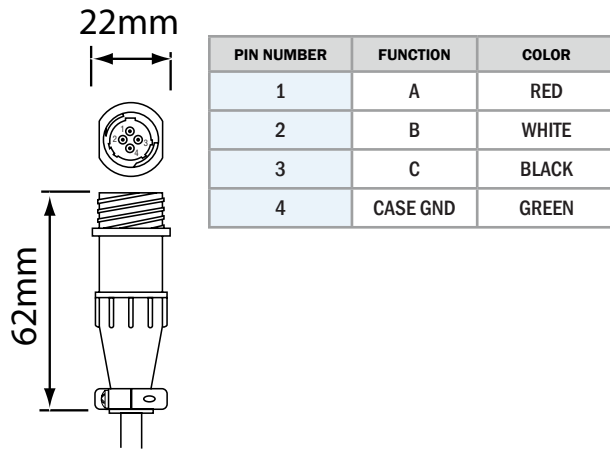

	CONNECTOR	MATING CONNECTOR
HOUSING	AMP# 206153-1	AMP# 206060-1
PINS	AMP# 1-66099-4 (4 pcs)	AMP# 1-66101-4 (4 pcs)
CABLE CLAMP	AMP# 206062-3	AMP# 206062-3

MOTOR WITH BRAKE CONNECTION

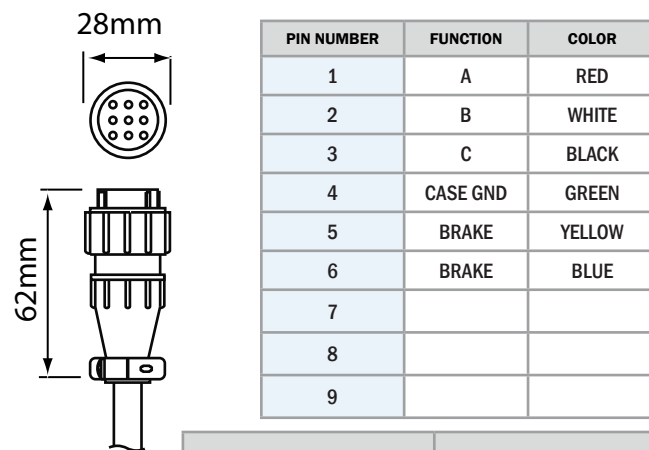

	CONNECTOR	MATING CONNECTOR
HOUSING	AMP# 206705-2	AMP# 206708-1
PINS	AMP# 1-66099-4 (4 pcs) AMP# 1-66103-2 (2 pcs)	AMP# 66101-4 (4 pcs) AMP# 66105-3 (2 pcs)
CABLE CLAMP	AMP# 206966-1	AMP# 206963-1

E.D.C.M. Explanation

E.D.C.M.

Some values in this catalog are quoted in E.D.C.M (Equivalent DC Motor). The diagram below shows how these values are derived with respect to line to line values.

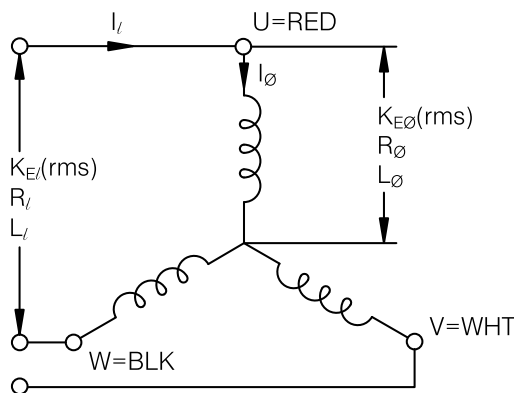

	E.D.C.M.	LINE	PHASE
CURRENT:	$I(rms)$	$= I_l(rms)$	$= I_ø(rms)$
VOLTAGE CONSTANT:	$K_E(rms)$	$= \sqrt{3} \times K_{E_l}(rms)$	$= 3 \times K_{Eø}(rms)$
ARMATURE RESISTANCE:	R_a	$= 1.5 \times R_l$	$= 3 \times R_ø$
ARMATURE INDUCTANCE:	L_a	$= 1.5 \times L_l$	$= 3 \times L_ø$