

REVISIONS				
REV	ECO	DESCRIPTION	DATE	APPROVED
A	8414	INITIAL RELEASE	2/6/20	J.KORDIK

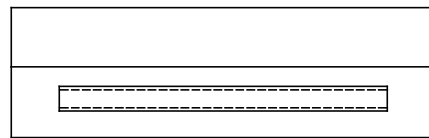

SIDE VIEW

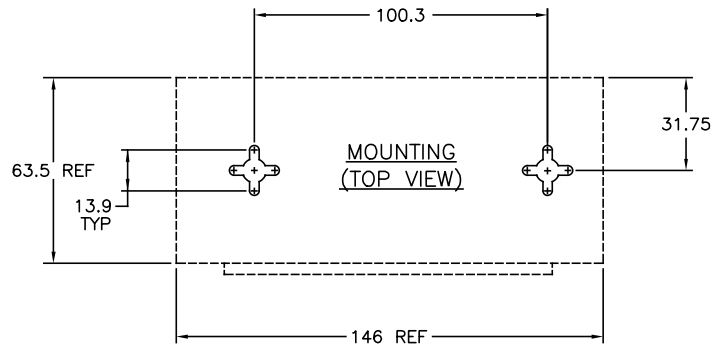
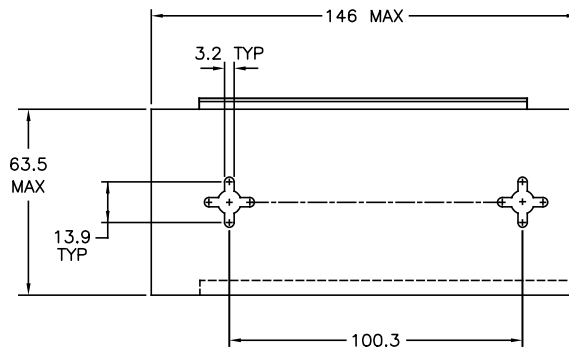

BOTTOM VIEW

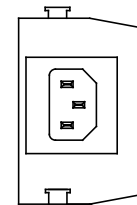

POWER CONNECTOR VIEW

TECHNICAL DETAILS	
PASS THROUGH DATA RATES	10/100/1000 Mbps
POE PORTS	1
STANDARDS	IEEE 802.3at/af
OUTPUT VOLTAGE	52 VDC MAX
AC INPUT VOLTAGE	100 ~ 240 VAC
AC INPUT CURRENT	0.8A @ 100-240 VAC
AC FREQUENCY	50 TO 60 Hz
PORT POWER	30 WATTS MAX
WEIGHT	0.35 lbs/ 0.16 kg
INDICATORS	SYSTEM: AC POWER (GREEN)
CONNECTORS	RJ-45
PIN ASSIGNMENT	1/2(+), 3/6(-) OR 4/5(+), 7/8(-)
REGULATORY	RoHS COMPLIANT, CE/FCC
SAFETY APPROVALS	EN 60950:2006

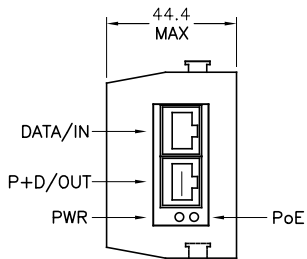

DATA CONNECTOR VIEW

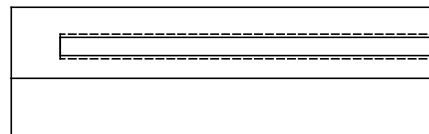

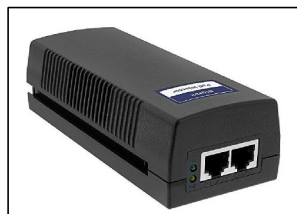

SIDE VIEW



NOTES: UNLESS OTHERWISE SPECIFIED

1. RECOMMENDED MOUNTING SCREW IS #6 PAN HEAD.
2. DIMENSIONS ARE REFERENCE ONLY, MEASURE BEFORE INSTALLATION.

TOLERANCES	THIRD ANGLE PROJECTION	APPLIED MOTION PRODUCTS, INC.												
DECIMALS: MM X.XXX = ±0.127 X.XX = ±0.25 X.X = ±2.5 ANGLES: MACH. = ±.5° CHAM. = ±5°		 APPLIED MOTION PRODUCTS, INC. POE-I100G INJECTOR MOUNTING DETAILS												
COMPUTER DATA BASE DRAWING	<table border="1"> <tr> <td>APPROVALS</td> <td>DATE</td> </tr> <tr> <td>DRAWN R. JONEZ</td> <td>2/4/20</td> </tr> <tr> <td>CHECKED</td> <td>-</td> </tr> <tr> <td>APPROVED</td> <td>-</td> </tr> </table>			APPROVALS	DATE	DRAWN R. JONEZ	2/4/20	CHECKED	-	APPROVED	-	<table border="1"> <tr> <td>DWG NO.</td> <td>REV</td> </tr> <tr> <td>1000-382</td> <td>A</td> </tr> </table>	DWG NO.	REV
APPROVALS	DATE													
DRAWN R. JONEZ	2/4/20													
CHECKED	-													
APPROVED	-													
DWG NO.	REV													
1000-382	A													
	SCALE: NONE	SHEET 1 OF 1												