

FD060-60C-CM

FlexPro® Series

Product Status: Active

SPECIFICATIONS

| | |
|-----------------------|--------------------|
| Current Continuous | 60 A |
| DC Supply Voltage | 10 – 55 VDC |
| Network Communication | CANopen |



The **FD060-60C-CM** is a servo drive and development board assembly for a FE060-60C-CM FlexPro® series servo drive with IMPACT™ architecture. Connections to the controller, motor, power, and feedback are simplified through the standard connectors featured on the board. The **FD060-60C-CM** is ideal for prototyping and can be used in production and industrial environments as well.

The **FD060-60C-CM** offers full tuning control of all servo loops and is designed to drive brushed and brushless servo motors, stepper motors, and AC induction motors. The drive assembly accepts a variety of external command signals, or can use the built-in Motion Engine, an internal motion controller used with Sequencing and Indexing commands. Programmable digital and analog I/O are included to enhance interfacing with external controllers and devices.

The **FD060-60C-CM** utilizes CANopen network communication and is configured via USB. All drive and motor parameters are stored in non-volatile memory.

IMPACT™ (Integrated Motion Platform And Control Technology) combines exceptional processing capability and high-current components to create powerful, compact, feature-loaded servo solutions. IMPACT™ is used in all FlexPro® drives and is available in custom products as well.

FEATURES

- Follows the CAN in Automation (CiA) 301 Communications Profile and 402 Device Profile
- Four Quadrant Regenerative Operation
- Programmable Gain Settings
- PIDF Velocity Loop
- On-the-Fly Mode Switching
- On-the-Fly Gain Set Switching
- Dedicated Safe Torque Off (STO) Inputs
- Bridge Status, Fault and Network Status LEDs
- I/O Status LEDs
- Standard Connections for Easy Setup

| | | | | | |
|---------------------------|---|-------------------------|--|---------------------------|--|
| Feedback Supported | <ul style="list-style-type: none"> • Absolute Encoder <ul style="list-style-type: none"> ◦ BiSS C-Mode ◦ EnDat 2.2 • Incremental Encoder • Hall Sensors • Aux Incremental Encoder • Tachometer (±10V) | Motors Supported | <ul style="list-style-type: none"> • Three Phase • Single Phase • Stepper • AC Induction | Modes of Operation | <ul style="list-style-type: none"> • Profile Modes • Cyclic Synchronous Modes • Current • Velocity • Position • Interpolated Position Mode (PVT) |
| Command Sources | <ul style="list-style-type: none"> • Over the Network • ±10V Analog • Sequencing • Indexing • Jogging • Step & Direction • Encoder Following | Inputs / Outputs | <ul style="list-style-type: none"> • 4 Programmable Digital Inputs • 3 Programmable Digital Outputs • 1 Programmable Analog Input | Agency Approvals | <ul style="list-style-type: none"> • RoHS • UL (Pending) • CE (Pending) • TUV Rheinland (STO) (Pending) |

BLOCK DIAGRAM

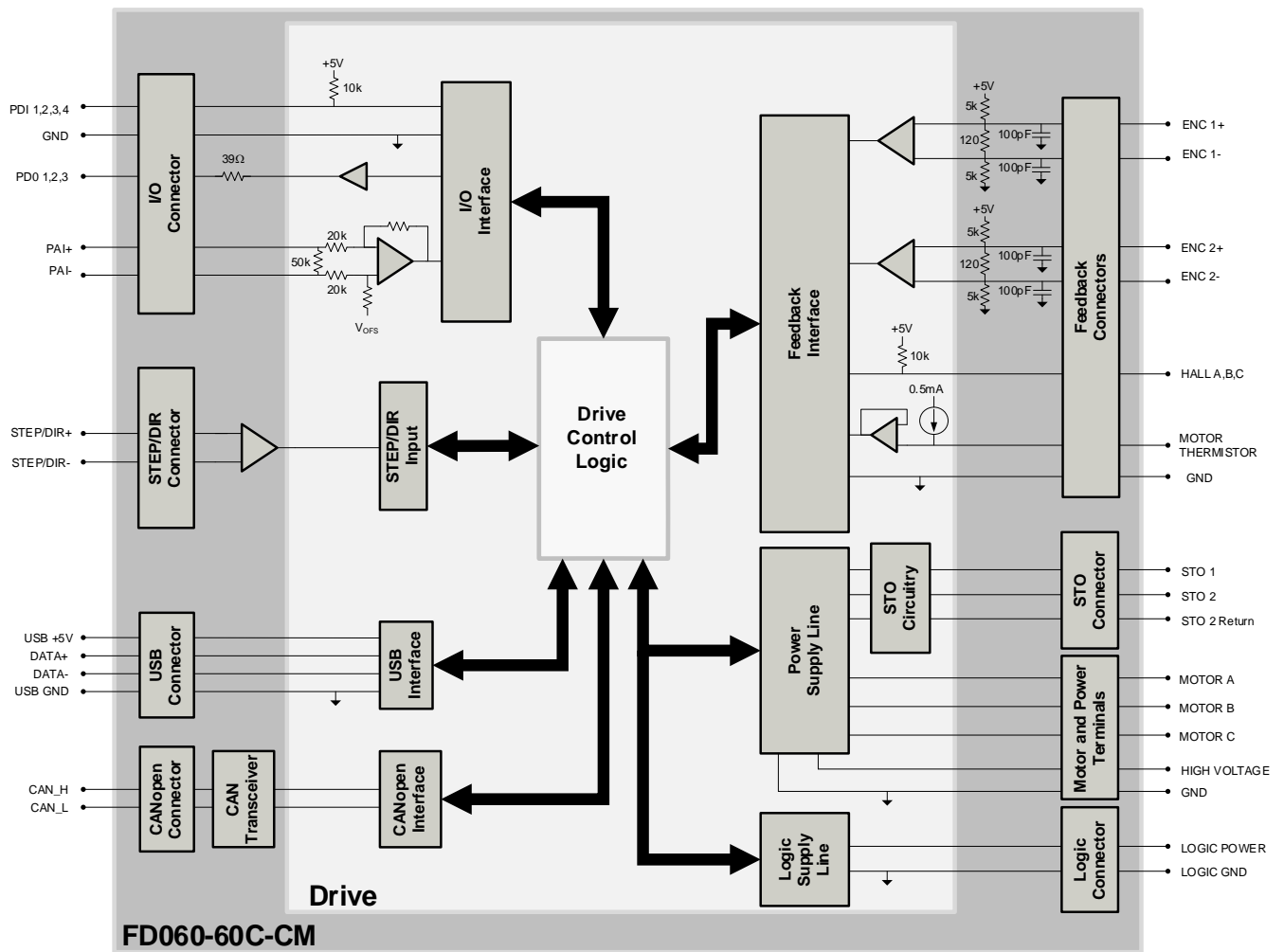

INFORMATION ON APPROVALS AND COMPLIANCES



The RoHS Directive restricts the use of certain substances including lead, mercury, cadmium, hexavalent chromium and halogenated flame retardants PBB and PBDE in electronic equipment.

SPECIFICATIONS

| Description | Electrical Specifications | |
|---|---------------------------|--|
| | Units | Value |
| Nominal DC Supply Input Range | VDC | 12 – 48 |
| DC Supply Input Range | VDC | 10 – 55 |
| DC Supply Undervoltage | VDC | 8 |
| DC Supply Overvoltage | VDC | 58 |
| Logic Supply Input Range (required) | VDC | 10 – 55 |
| Safe Torque Off Voltage (Default) | VDC | 5 |
| Bus Capacitance | µF | 500 |
| Maximum Continuous Current Output ¹ | A (Arms) | 60 (60) |
| Efficiency at Rated Power | % | 99 |
| Maximum Continuous Output Power | W | 3267 |
| Maximum Power Dissipation at Rated Power | W | 33 |
| Minimum Load Inductance (line-to-line) ² | µH | 150 (@ 48VDC supply); 75 (@24VDC supply); 40 (@12VDC supply) |
| Switching Frequency | kHz | 20 |
| Maximum Output PWM Duty Cycle | % | 83 |

| Description | Control Specifications | |
|-------------------------------------|------------------------|---|
| | Units | Value |
| Communication Interfaces | - | CANopen (USB for configuration) |
| Command Sources | - | ±10 V Analog, Over the Network, Sequencing, Indexing, Jogging, Step & Direction, Encoder Following |
| Feedback Supported | - | Absolute Encoder (BiSS C-Mode, EnDat 2.2), Incremental Encoder, Hall Sensors, Auxiliary Incremental Encoder, Tachometer (±10V) |
| Commutation Methods | - | Sinusoidal, Trapezoidal |
| Modes of Operation | - | Profile Modes, Cyclic Synchronous Modes, Current, Velocity, Position, Interpolated Position Mode (PVT) |
| Motors Supported ³ | - | Three Phase (Brushless Servo), Single Phase (Brushed Servo, Voice Coil, Inductive Load), Stepper (2- or 3-Phase Closed Loop), AC Induction (Closed Loop Vector) |
| Hardware Protection | - | 40+ Configurable Functions, Over Current, Over Temperature (Drive & Motor), Over Voltage, Short Circuit (Phase-Phase & Phase-Ground), Under Voltage |
| Programmable Digital Inputs/Outputs | - | 4/3 |
| Programmable Analog Inputs/Outputs | - | 1/0 |
| Primary I/O Logic Level | - | 5 VDC, not isolated |
| Current Loop Sample Time | µs | 50 |
| Velocity Loop Sample Time | µs | 100 |
| Position Loop Sample Time | µs | 100 |
| Maximum Encoder Frequency | MHz | 20 (5 pre-quadrature) |

| Description | Mechanical Specifications | |
|--|---------------------------|--|
| | Units | Value |
| Size (H x W x D) | mm (in) | 114.3 x 91.4 x 26.0 (4.50 x 3.60 x 1.03) |
| Weight | g (oz) | 178.5 (6.3) |
| Ambient Operating Temperature Range ⁴ | °C (°F) | 0 – 65 (32 – 149) |
| Storage Temperature Range | °C (°F) | -40 – 85 (-40 – 185) |
| Relative Humidity | - | 0-95%, non-condensing |
| P2 LOGIC POWER CONNECTOR | - | 2-port Screw Terminal |
| P3 USB COMMUNICATION CONNECTOR | - | 5-pin, Mini USB B Type port |
| P5 CANopen COMMUNICATION CONNECTORS | - | 8-pin, dual row, 2.00 mm spaced plug terminal |
| P6 STO CONNECTOR | - | 8-pin 2.00 mm spaced, enclosed, friction lock header |
| P7 IO CONNECTOR | - | 12-pin 2.00 mm spaced dual-row plug terminal |
| P8 STEP/DIR CONNECTOR | - | 8-pin 2.00 mm spaced dual-row plug terminal |
| P9 FEEDBACK 2 CONNECTOR | - | 15-pin vertical D-Sub |
| P10 FEEDBACK 1 CONNECTOR | - | 15-pin vertical D-Sub |
| P11/12/13 MOTOR POWER TERMINALS | - | 3x Hex Screw Lug |
| P14/15 DC POWER TERMINALS | - | 2x Hex Screw Lug |

Notes

1. Continuous I_{Arms} value attainable when RMS Charge-Based Limiting is used.
2. Lower inductance is acceptable for bus voltages well below maximum. Use external inductance to meet requirements.
3. Maximum motor speed for stepper motors is 600 RPM. Consult the hardware installation manual for 2-phase stepper wiring configuration.
4. Additional cooling and/or heatsink may be required to achieve rated performance.

PIN FUNCTIONS

P2 – Logic Power Connector

| Pin | Name | Description / Notes | I/O |
|-----|-----------|--|-----|
| 1 | LOGIC PWR | Logic Supply Input (10 – 55VDC) (required) | I |
| 2 | LOGIC GND | Ground | GND |

| | | |
|----------------------------------|-----------------------|--|
| Connector Information | 2-port Screw Terminal | |
| Mating Connector Details | N/A | |
| Mating Connector Included | N/A | |

P3 – USB Communication Connector

| Pin | Name | Description / Notes | I/O |
|-----|----------|---------------------|-----|
| 1 | VBUS | Supply Voltage | O |
| 2 | DATA- | Data - | I/O |
| 3 | DATA+ | Data + | I/O |
| 4 | RESERVED | Reserved. | - |
| 5 | GND | Ground | GND |

| | | |
|----------------------------------|--|--|
| Connector Information | 5-pin, Mini USB B Type port | |
| Mating Connector Details | TYCO: 1496476-3 (2-meter STD-A to MINI-B ASSY) | |
| Mating Connector Included | No | |

P5 – CANopen Communication Connector

| Pin | Name | Description / Notes | I/O |
|-----|----------|--------------------------------|-----|
| 1 | RESERVED | Reserved. | - |
| 2 | RESERVED | Reserved. | - |
| 3 | RESERVED | Reserved. | - |
| 4 | RESERVED | Reserved. | - |
| 5 | GND | Ground | GND |
| 6 | GND | Ground | GND |
| 7 | CAN_H | CAN_H bus line (dominant high) | I/O |
| 8 | CAN_L | CAN_L bus line (dominant low) | I/O |

| | | |
|----------------------------------|--|--|
| Connector Information | 8-pin, dual row, 2.00 mm spaced plug terminal | |
| Mating Connector Details | Molex: P/N 51353-0800 (housing); 56134-9100 (contacts) | |
| Mating Connector Included | Yes | |

| P6 – STO Connector | | | |
|--------------------|-------------|---------------------------|--------|
| Pin | Name | Description / Notes | I/O |
| 1 | RESERVED | Reserved. | - |
| 2 | RESERVED | Reserved. | - |
| 3 | STO RETURN | Safe Torque Off Return | STORET |
| 4 | STO-1 INPUT | Safe Torque Off – Input 1 | I |
| 5 | STO RETURN | Safe Torque Off Return | STORET |
| 6 | STO-2 INPUT | Safe Torque Off – Input 2 | I |
| 7 | RESERVED | Reserved. | - |
| 8 | RESERVED | Reserved. | - |

| | | |
|----------------------------------|--|--|
| Connector Information | 8-port, 2.00 mm spaced, enclosed, friction lock header | |
| Mating Connector Details | Molex: P/N 51110-0860 (housing); 50394-8051 (pins) | |
| Mating Connector Included | Yes | |

| P7 – IO Connector | | | |
|-------------------|----------|--|-----|
| Pin | Name | Description / Notes | I/O |
| 1 | PDI-1 | General Purpose Programmable Digital Input | I |
| 2 | PDI-2 | General Purpose Programmable Digital Input | I |
| 3 | PDI-3 | General Purpose Programmable Digital Input | I |
| 4 | PDI-4 | General Purpose Programmable Digital Input | I |
| 5 | PDO-1 | General Purpose Programmable Digital Output (TTL/8mA) | O |
| 6 | PDO-2 | General Purpose Programmable Digital Output (TTL/8mA) | O |
| 7 | PDO-3 | General Purpose Programmable Digital Output (TTL/8mA) | O |
| 8 | +5V_USER | +5V Supply Output. Short-circuit protected. (300ma total load capacity shared between P7-8, P8-7, P9-13, and P10-13) | O |
| 9 | GND | Ground. | GND |
| 10 | GND | Ground. | GND |
| 11 | PAI-1+ | General Purpose Differential Programmable Analog Input or Reference Signal Input. ±10VDC Range (12-bit Resolution) | I |
| 12 | PAI-1- | | I |

| | | |
|----------------------------------|--|--|
| Connector Information | 12-pin, dual row, 2.00 mm spaced plug terminal | |
| Mating Connector Details | Molex: P/N 51353-1200 (housing); 56134-9100 (contacts) | |
| Mating Connector Included | Yes | |

| P8 – STEP/DIR Connector | | | |
|-------------------------|----------|--|-----|
| Pin | Name | Description / Notes | I/O |
| 1 | STEP + | Differential Step Input. | I |
| 2 | STEP - | | I |
| 3 | DIR + | Differential Direction Input. | I |
| 4 | DIR - | | I |
| 5 | RESERVED | Reserved. | - |
| 6 | RESERVED | | - |
| 7 | +5V_USER | +5V Supply Output. Short-circuit protected. (300ma total load capacity shared between P7-8, P8-7, P9-13, and P10-13) | O |
| 8 | GND | Ground. | GND |

| | | |
|----------------------------------|--|--|
| Connector Information | 8-pin, dual row, 2.00 mm spaced plug terminal | |
| Mating Connector Details | Molex: P/N 51353-0800 (housing); 56134-9100 (contacts) | |
| Mating Connector Included | Yes | |

P9 – Feedback 2 Connector



| Pin | Incremental Encoder | Description / Notes | I/O |
|-----|---------------------|--|-----|
| 1 | HALL A | Single-ended Commutation Sensor Inputs. Signals shared with Feedback 1 connector. Use only Hall connections on either Feedback 1 or Feedback 2. | I |
| 2 | HALL B | | I |
| 3 | HALL C | | I |
| 4 | ENC 2 A+ | Differential Incremental Encoder A. | I |
| 5 | ENC 2 A- | | I |
| 6 | ENC 2 B+ | | I |
| 7 | ENC 2 B- | Differential Incremental Encoder B. | I |
| 8 | ENC 2 INDEX+ | | I |
| 9 | ENC 2 INDEX- | | I |
| 10 | RESERVED | Reserved. | - |
| 11 | RESERVED | Reserved. | - |
| 12 | GND | Ground. | GND |
| 13 | +5V_USER | +5V Supply Output. Short-circuit protected. (300ma total load capacity shared between P7-8, P8-7, P9-13, and P10-13) | O |
| 14 | THERMISTOR | Motor Thermal Protection. Select which Thermistor pin is active using DIP Switch SW6 (see Board Configuration section below). Only one Thermistor pin between Feedback 1 and Feedback 2 Connector can be active. | I |
| 15 | RESERVED | Reserved. | - |



| | | |
|----------------------------------|--|--|
| Connector Information | 15-pin, high-density, female D-sub | |
| Mating Connector Details | TYCO: Plug P/N 748364-1; Housing P/N 5748677-2; Terminals P/N 1658670-2 (loose) or 1658670-1 (strip) | |
| Mating Connector Included | No | |

P10 – Feedback 1 Connector

| Pin | Absolute Encoder | Incremental Encoder | Description / Notes | I/O |
|-----|------------------|---------------------|--|--|
| 1 | HALL A | HALL A | Single-ended Commutation Sensor Inputs. Signals shared with Feedback 2 connector. Use only Hall connections on either Feedback 1 or Feedback 2. | I |
| 2 | HALL B | HALL B | | I |
| 3 | HALL C | HALL C | | I |
| 4 | ENC 1 DATA+ | ENC 1 A+ | Differential Data Line for Absolute Encoders (BiSS: SLO+/-) or Differential Incremental Encoder A. | I |
| 5 | ENC 1 DATA- | ENC 1 A- | | I |
| 6 | ENC 1 CLOCK+ | ENC 1 B+ | | Differential Clock Line for Absolute Encoders (BiSS: MA+/-) or Differential Incremental Encoder B. |
| 7 | ENC 1 CLOCK- | ENC 1 B- | I | |
| 8 | ENC 1 REF MARK+ | ENC 1 I+ | Differential Reference Mark for Absolute Encoders (Leave open for BiSS and EnDat 2.2) or Differential Incremental Encoder Index. | |
| 9 | ENC 1 REF MARK- | ENC 1 I- | | I |
| 10 | RESERVED | RESERVED | | Reserved. |
| 11 | RESERVED | RESERVED | Reserved. | - |
| 12 | GND | GND | Ground. | GND |
| 13 | +5V_USER | +5V_USER | +5V Supply Output. Short-circuit protected. (300ma total load capacity shared between P7-8, P8-7, P9-13, and P10-13) | O |
| 14 | THERMISTOR | THERMISTOR | Motor Thermal Protection. Select which Thermistor pin is active using DIP Switch SW6 (see Board Configuration section below). Only one Thermistor pin between Feedback 1 and Feedback 2 Connector can be active. | I |
| 15 | RESERVED | RESERVED | Reserved. | - |

| | | |
|----------------------------------|--|--|
| Connector Information | 15-pin, high-density, female D-sub | |
| Mating Connector Details | TYCO: Plug P/N 748364-1; Housing P/N 5748677-2; Terminals P/N 1658670-2 (loose) or 1658670-1 (strip) | |
| Mating Connector Included | No | |

| P11/12/13 - Motor Power Terminals | | | |
|-----------------------------------|---------|------------------------|--|
| Pin | Name | Description / Notes | I/O |
| 1 | MOTOR A | Motor Phase A. | ○ |
| 2 | MOTOR B | Motor Phase B. | ○ |
| 3 | MOTOR C | Motor Phase C. | ○ |
| Connector Information | | Bushings with M4 Screw | <div style="display: flex; justify-content: space-around; align-items: center;"> <div style="text-align: center;"> <p>MOTOR C</p>  </div> <div style="text-align: center;"> <p>MOTOR B</p>  </div> <div style="text-align: center;"> <p>MOTOR A</p>  </div> </div> |
| Mating Connector Details | | N/A | |
| Mating Connector Included | | N/A | |

| P14/15 - DC Power Terminals | | | |
|----------------------------------|-----------|------------------------------|---|
| Pin | Name | Description / Notes | I/O |
| 1 | HV | DC Supply Input (10-55 VDC). | I |
| 2 | POWER GND | Ground. | GND |
| Connector Information | | Bushings with M4 Screw | <div style="display: flex; justify-content: space-around; align-items: center;"> <div style="text-align: center;"> <p>HV</p>  </div> <div style="text-align: center;"> <p>POWER GND</p>  </div> </div> |
| Mating Connector Details | | N/A | |
| Mating Connector Included | | N/A | |

BOARD CONFIGURATION
Status LED Functions

| LED | Description |
|-----------|---|
| STAT | Indicates drive power bridge status. GREEN when DC bus power is applied and the drive is enabled. RED when the drive is in a fault state. |
| LOGIC PWR | Indicates that +5V logic power is available to the drive. GREEN when +5V logic power is available. |
| EMA | Indicates whether the Emulated Encoder Output functionality is active. GREEN for Emulated Encoder Output active. OFF for Step & Direction Input or PWM & Direction Input. |
| SEL | Indicates whether CANopen communication is selected. GREEN for CANopen. |

Input/Output LED Functions

| LED | Description |
|-----------|---|
| DI1 – DI4 | Indicates digital input status. GREEN when the corresponding digital input is active. |
| DO1 – DO3 | Indicates digital output status. BLUE when the corresponding digital output is active |

CANopen Node ID Switches

| Switch Diagram | Description | | | | | | | | | | | | | | | | | | | | | | | | |
|---------------------|---|-----------------------|-----|---------|---|---|-----------------------|---|---|-----|---|---|-----|-----|-----|-----|---|---|----|---|---|----|---|---|----|
| <p>SW3 SW4</p> | <p>Hexadecimal switch settings correspond to the CANopen Node ID. Allowable CANopen Node ID range using the rotary switches is 1 - 63. Node IDs above 63 can be set via ACE setup software or network commands and stored to NVM (up to a Node ID of 127). Setting the rotary switches to zero will use the address stored in NVM.</p> <table border="1"> <thead> <tr> <th>SW3</th> <th>SW4</th> <th>Node ID</th> </tr> </thead> <tbody> <tr> <td>0</td> <td>0</td> <td>Address stored in NVM</td> </tr> <tr> <td>0</td> <td>1</td> <td>001</td> </tr> <tr> <td>0</td> <td>2</td> <td>002</td> </tr> <tr> <td>...</td> <td>...</td> <td>...</td> </tr> <tr> <td>3</td> <td>D</td> <td>61</td> </tr> <tr> <td>3</td> <td>E</td> <td>62</td> </tr> <tr> <td>3</td> <td>F</td> <td>63</td> </tr> </tbody> </table> | SW3 | SW4 | Node ID | 0 | 0 | Address stored in NVM | 0 | 1 | 001 | 0 | 2 | 002 | ... | ... | ... | 3 | D | 61 | 3 | E | 62 | 3 | F | 63 |
| SW3 | SW4 | Node ID | | | | | | | | | | | | | | | | | | | | | | | |
| 0 | 0 | Address stored in NVM | | | | | | | | | | | | | | | | | | | | | | | |
| 0 | 1 | 001 | | | | | | | | | | | | | | | | | | | | | | | |
| 0 | 2 | 002 | | | | | | | | | | | | | | | | | | | | | | | |
| ... | ... | ... | | | | | | | | | | | | | | | | | | | | | | | |
| 3 | D | 61 | | | | | | | | | | | | | | | | | | | | | | | |
| 3 | E | 62 | | | | | | | | | | | | | | | | | | | | | | | |
| 3 | F | 63 | | | | | | | | | | | | | | | | | | | | | | | |

DIP Switches

| Switch | Description | ON | OFF |
|--------|---|--|---|
| SW6 | Motor Thermistor Selection. Note that both switches on SW6 must be set to the same position for proper operation. | Uses the motor thermistor reading from P9 – Feedback 2 Connector | Uses the motor thermistor reading from P10 – Feedback 1 Connector |
| SW9 | CAN Termination. The last device in a CAN network requires termination. Note that both switches on SW9 must be set to the same position for proper operation. | Terminated | Not terminated |
| SW10 | CAN Communication Selection. Note that all 4 switches of SW10 and SW11 must be set to the same position for proper operation. | RS232/485 | CAN |
| SW11 | | | |

Safe Torque Off (STO) Inputs

The Safe Torque Off (STO) inputs are dedicated +5VDC sinking single-ended inputs. For applications not using STO functionality, disabling of the STO feature is required for proper drive operation. STO may be disabled by installing the included mating connector for the STO connector and following the STO Disable wiring instructions as given in the hardware installation manual. Consult the hardware installation manual for more information. Alternatively, a dedicated STO Disable Key connector is available for purchase for applications where STO is not in use. Contact the factory for ordering information.

MOUNTING DIMENSIONS

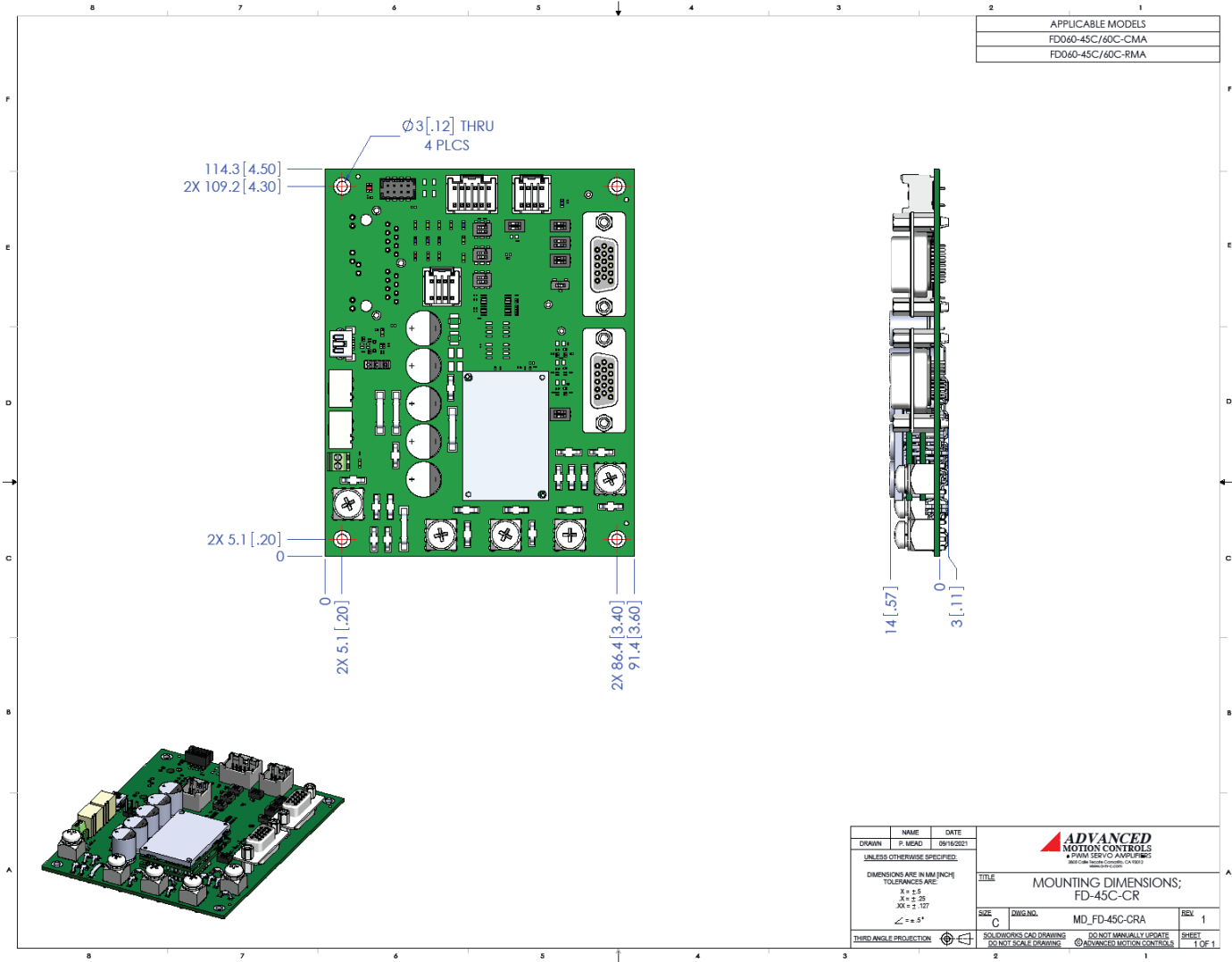

PART NUMBERING AND CUSTOMIZATION INFORMATION

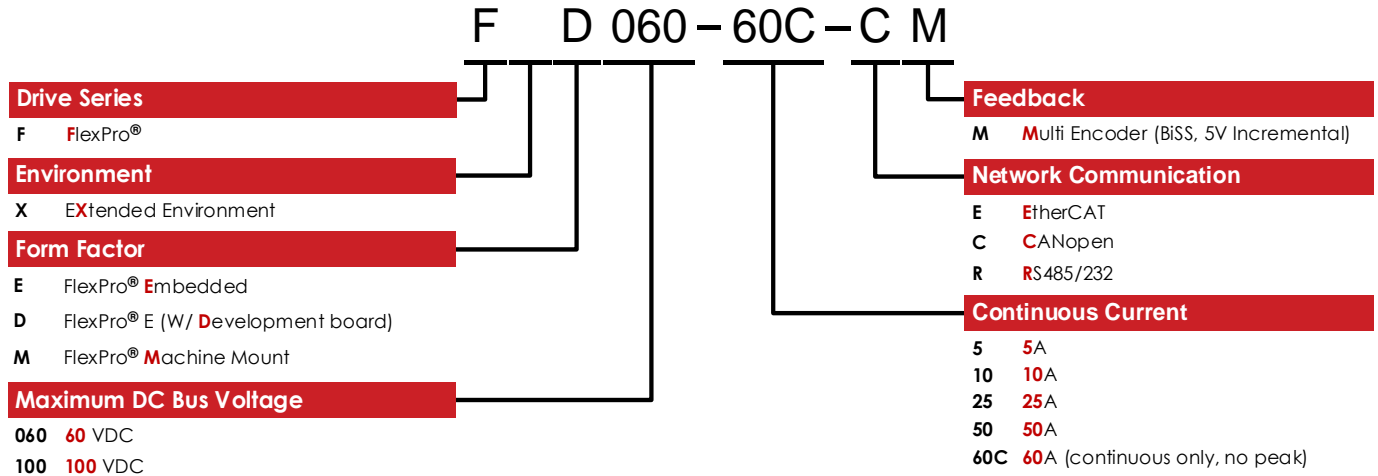

ADVANCED Motion Controls also has the capability to promptly develop and deliver specified products for OEMs with volume requests. Our Applications and Engineering Departments will work closely with your design team through all stages of development in order to provide the best servo drive solution for your system. Equipped with on-site manufacturing for quick-turn customs capabilities, ADVANCED Motion Controls utilizes our years of engineering and manufacturing expertise to decrease your costs and time-to-market while increasing system quality and reliability.

Examples of Customized Products

- | | |
|--|--|
| <ul style="list-style-type: none"> ▲ Optimized Footprint ▲ Private Label Software ▲ OEM Specified Connectors ▲ No Outer Case ▲ Increased Current Resolution ▲ Increased Temperature Range ▲ Custom Control Interface ▲ Integrated System I/O | <ul style="list-style-type: none"> ▲ Tailored Project File ▲ Silkscreen Branding ▲ Optimized Base Plate ▲ Increased Current Limits ▲ Increased Voltage Range ▲ Conformal Coating ▲ Multi-Axis Configurations ▲ Reduced Profile Size and Weight |
|--|--|

Feel free to contact us for further information and details!

Available Accessories

ADVANCED Motion Controls offers a variety of accessories designed to facilitate drive integration into a servo system. Visit www.a-m-c.com to see which accessories will assist with your application design and implementation.

All specifications in this document are subject to change without written notice. Actual product may differ from pictures provided in this document.