

Description

The PS50A non-isolated unregulated power supplies are designed to complement **ADVANCED Motion Controls'** high voltage servo drives. These power supplies contain a rectifier bridge and filter capacitors to generate the DC bus internally from the AC input power. These DC power supplies are an excellent solution for multi-axis applications since **ADVANCED** Motion Controls' servo drives compensate for power supply output variations and AC ripple components.

- ▲ Surface-Mount Technology
- ▲ Accepts Three Phase or Single Phase AC Supply
- ▲ Built-In Shunt Regulator with Bicolor LED Indicator
- ▲ External Shunt Resistor Provisions
- ▲ Compact Design

Power Ratings

Model Number	AC Input Supply	DC Output Voltage	Output Current	Output Power
PS50A	240 VAC	340 VDC	50 A	17 kW
PS50A-LV	120 VAC	170 VDC	50 A	8.5 kW



PS50A Series Power Supply

Operation

The DC bus voltage is 1.4 times AC voltage (RMS), e.g. 340 VDC from 240 VAC for the PS30A and 170 VDC from 120 VAC for the PS30A-LV. During braking much of the stored mechanical energy is fed back into the power supply and charges the bus capacitor to a higher voltage. If this voltage reaches the drive's over-voltage shutdown point, output current and braking will cease. To ensure smooth braking of large inertial loads, a built-in shunt regulator is provided.

The shunt regulator will switch on the internal power resistor when the bus voltage reaches the shunt switch-on voltage. This allows the bus capacitor to discharge and thus lower the bus voltage. During regeneration, the regeneration LED will blink (solid green is non-regeneration mode). An external shunt resistor can be added parallel to the internal resistor (between shunt terminals 1 and 2). Removing the jumper between shunt terminals 2 and 3 will disable the internal shunt resistor.

Agency Approvals



US and Canadian safety compliance with UL 508c, the industrial standard for power conversion electronics. UL registered under file number E140173. Note that machine components compliant with UL are considered UL registered as opposed to UL listed, as would be the case for commercial products.



Compliant with European CE for both the Class A EMC Directive 2004/108/EC on Electromagnetic Compatibility (specifically EN 61000-6-4:2001, EN 61000-6-2:2001, EN 61000-3-2:2000, and EN 61000-3-3:1995/A1:2001) and LVD requirements of directive 2006/95/EC (specifically EN 60204-1), a low voltage directive to protect users from electrical shock.



RoHS (Reduction of Hazardous Substances) is intended to prevent hazardous substances such as lead from being manufactured in electrical and electronic equipment.

SPECIFICATIONS

Power Specifications				
Description	Units	PS30A		PS30A-LV
AC Supply Voltage Input	VAC	240		120
AC Supply Input Frequency	Hz	50-60		
AC Supply Input Phases	-	1 or 3		
Continuous DC Current Output	A	50 (for three phase AC input) / 25 (for single phase AC input)		
Peak DC Current Output ¹	A	100 (for three phase AC input) / 50 (for single phase AC input)		
Internal Shunt Resistor	Ω	20		
Internal Shunt Resistor Power Rating	W	180		
Shunt Regulator Switch-On Voltage	VDC	390	190	
Bus Capacitance (@450V)	μF	2640	8000	
Shunt Fuse (motor delay rated @500 VAC)	A	5		
AC Line Fuses (slow blow rated @250 VAC)	A	30		

Mechanical Specifications				
Description	Units	PS30A		PS30A-LV
AC Connector C1	-	Screw Terminals		
DC Out and External Shunt Connector: C2	-	Screw Terminals		
Size (H x W x D)	mm (in)	234.92 x 195.71 x 79.68 (9.25 x 7.71 x 3.14)		
Weight	kg (lbs)	2.61 (5.74)		
Shunt Fuse (Diameter / Length)	mm (in)	10.32 / 38.10 (0.41 / 1.50)		
AC Line Fuses Size (Diameter / Length)	mm (in)	10.32 / 38.10 (0.41 / 1.50)		

Notes

- Maximum peak current is ~2 seconds.

BLOCK DIAGRAM

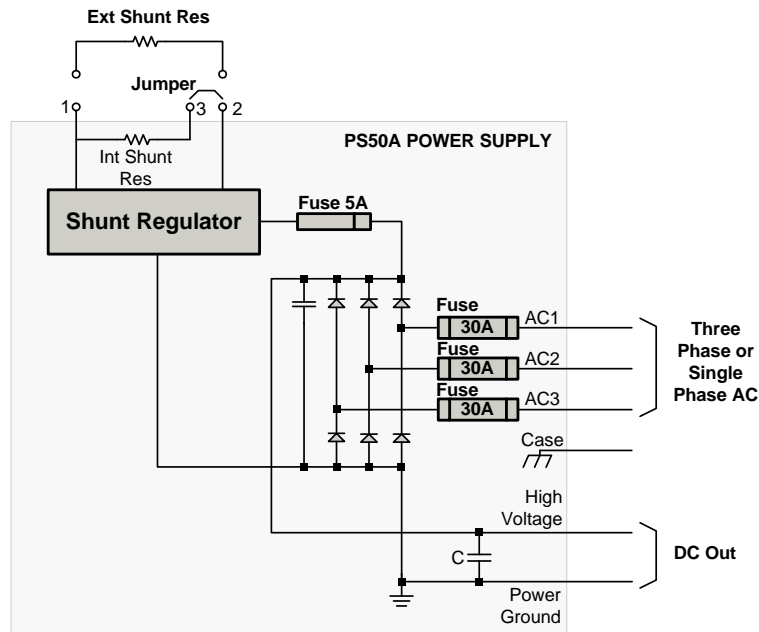

MOUNTING DIMENSIONS

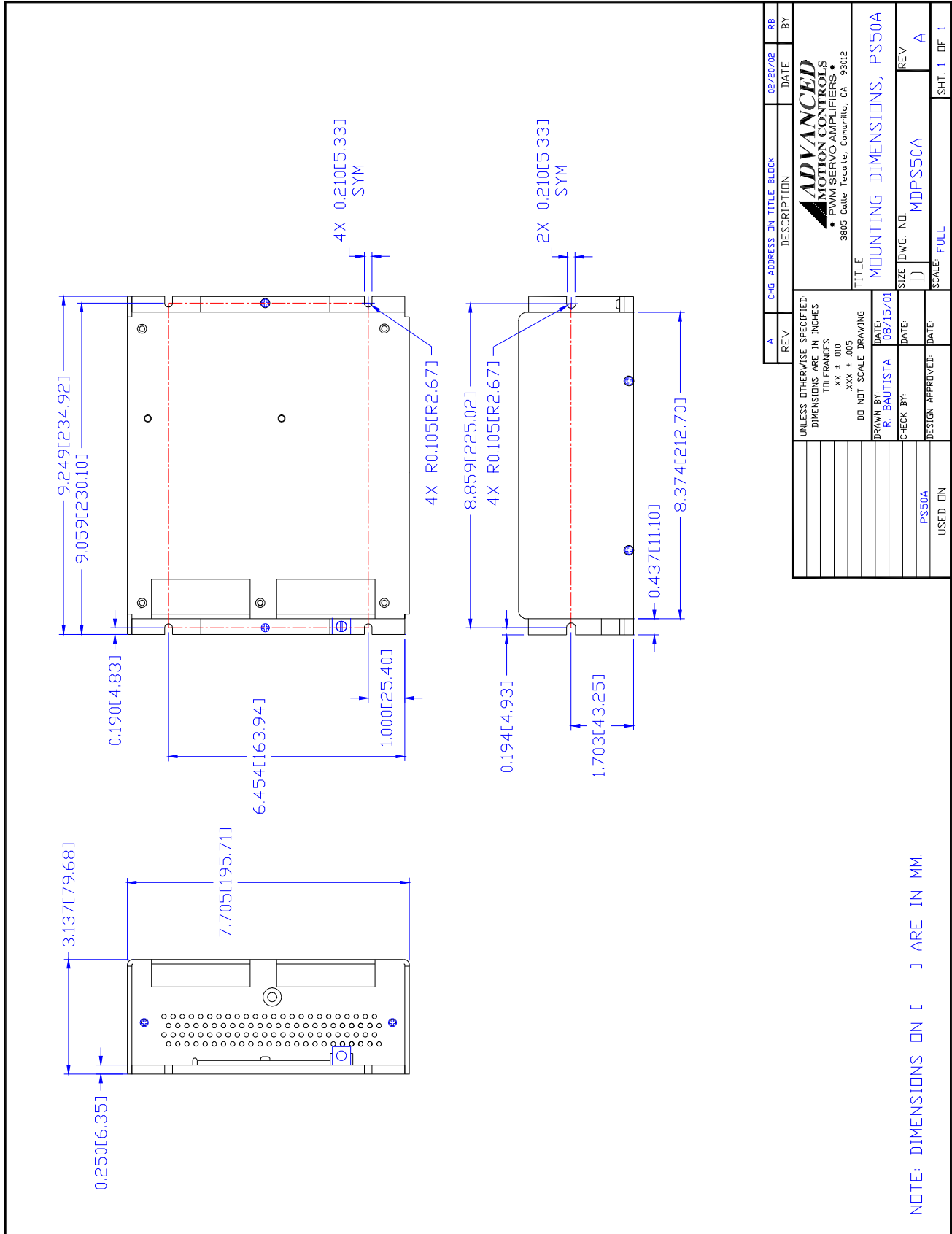

REV	CHG. ADDRESS	DN	TITLE	BLOCK	DESCRIPTION	DATE	BY
A						02/20/02	RB
<p>UNLESS OTHERWISE SPECIFIED: DIMENSIONS ARE IN INCHES TOLERANCES XX ± .010 XX ± .005 DO NOT SCALE DRAWING</p>							
<p>ADVANCED MOTION CONTROLS • PWM SERVO AMPLIFIERS • 3805 Calle Tecate, Conarillo, CA 93012</p>							
<p>TITLE: MOUNTING DIMENSIONS, PS50A</p>							
<p>SIZE [DWG. NO.]</p>							
<p>REVISION</p>							
<p>DESIGN APPROVED: DATE:</p>							
<p>CHECK BY: DATE:</p>							
<p>DRAWN BY: R. BAUTISTA DATE: 08/15/01</p>							
<p>SCALE: FULL</p>							
<p>SHT. 1 OF 1</p>							

CUSTOMIZATION INFORMATION

ADVANCED Motion Controls' products are available in many configurations. All models listed in the selection tables of the website are readily available, standard product offerings.

ADVANCED Motion Controls also has the capability to promptly develop and deliver specified products for OEMs with volume requests. Our Applications and Engineering Departments will work closely with your design team through all stages of development in order to provide the best servo drive solution for your system. Equipped with on-site manufacturing for quick-turn customs capabilities, *ADVANCED* Motion Controls utilizes our years of engineering and manufacturing expertise to decrease your costs and time-to-market while increasing system quality and reliability. Feel free to contact Applications Engineering for further information and details.

Examples of Customized Products

- | | |
|--------------------------------|-----------------------------------|
| ▲ Optimized Footprint | ▲ Tailored Project File |
| ▲ Private Label Software | ▲ Silkscreen Branding |
| ▲ OEM Specified Connectors | ▲ Optimized Base Plate |
| ▲ No Outer Case | ▲ Increased Current Limits |
| ▲ Increased Current Resolution | ▲ Increased Voltage Range |
| ▲ Increased Temperature Range | ▲ Conformal Coating |
| ▲ Custom Control Interface | ▲ Multi-Axis Configurations |
| ▲ Integrated System I/O | ▲ Reduced Profile Size and Weight |

Available Accessories

ADVANCED Motion Controls offers a variety of accessories designed to facilitate drive integration into a servo system. Visit www.a-m-c.com to see which accessories will assist with your application design and implementation.

