

Description

The AZBE60A8 PWM servo drive is designed to drive brushless and brushed DC motors at a high switching frequency. To increase system reliability and to reduce cabling costs, the drive is designed for direct integration into your PCB. The AZBE60A8 is fully protected against over-voltage, under-voltage, over-current, over-heating, invalid commutation, and short-circuits. A single digital output indicates operating status. The drive interfaces with digital controllers that have analog $\pm 10V$ output. The AZBE60A8 can utilize either quadrature encoder inputs or Tachometer feedback for velocity control. This servo drive requires only a single unregulated isolated DC power supply, and is fully RoHS (Reduction of Hazardous Substances) compliant.

See Part Numbering Information on last page of datasheet for additional ordering options.

Power Range

| | |
|--------------------|-------------|
| Peak Current | 60 A |
| Continuous Current | 30 A |
| Supply Voltage | 10 - 80 VDC |

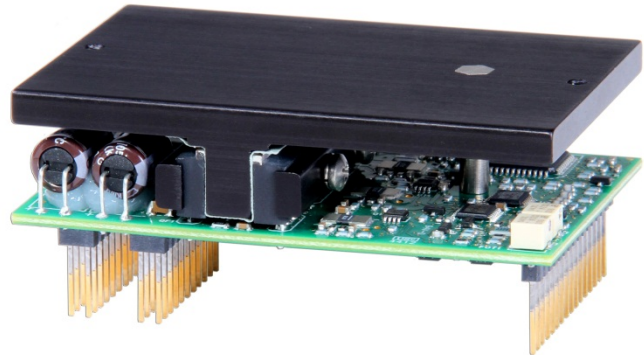

Features

- ▲ Four Quadrant Regenerative Operation
- ▲ Direct Board-to-Board Integration
- ▲ Lightweight
- ▲ High Switching Frequency
- ▲ High Performance Thermal Dissipation
- ▲ Differential Input Command
- ▲ Digital Fault Output Monitor
- ▲ 12VDC Operation
- ▲ Encoder Velocity Mode
- ▲ Current Monitor Output
- ▲ Compact Size
- ▲ High Power Density

HARDWARE PROTECTION

- Under-Voltage
- Over-Voltage
- Over-Current
- Over-Temperature
- Short-circuit (phase-phase)
- Short-circuit (phase-ground)

INPUTS/OUTPUTS

- Digital Fault Output
- Digital Inhibit Input
- Analog Current Monitor
- Analog Command Input
- Analog Current Reference

COMMUTATION

- Trapezoidal

FEEDBACK SUPPORTED

- Encoder
- Hall Sensors
- Tachometer (± 60 VDC)

MODES OF OPERATION

- Current
- Duty Cycle (Open Loop)
- Encoder Velocity
- Tachometer Velocity

MOTORS SUPPORTED

- Three Phase (Brushless)
- Single Phase (Brushed, Voice Coil, Inductive Load)

COMMAND SOURCE

- ± 10 V Analog



COMPLIANCES & AGENCY APPROVALS

- UL
- cUL
- CE Class A (LVD)
- CE Class A (EMC)
- RoHS

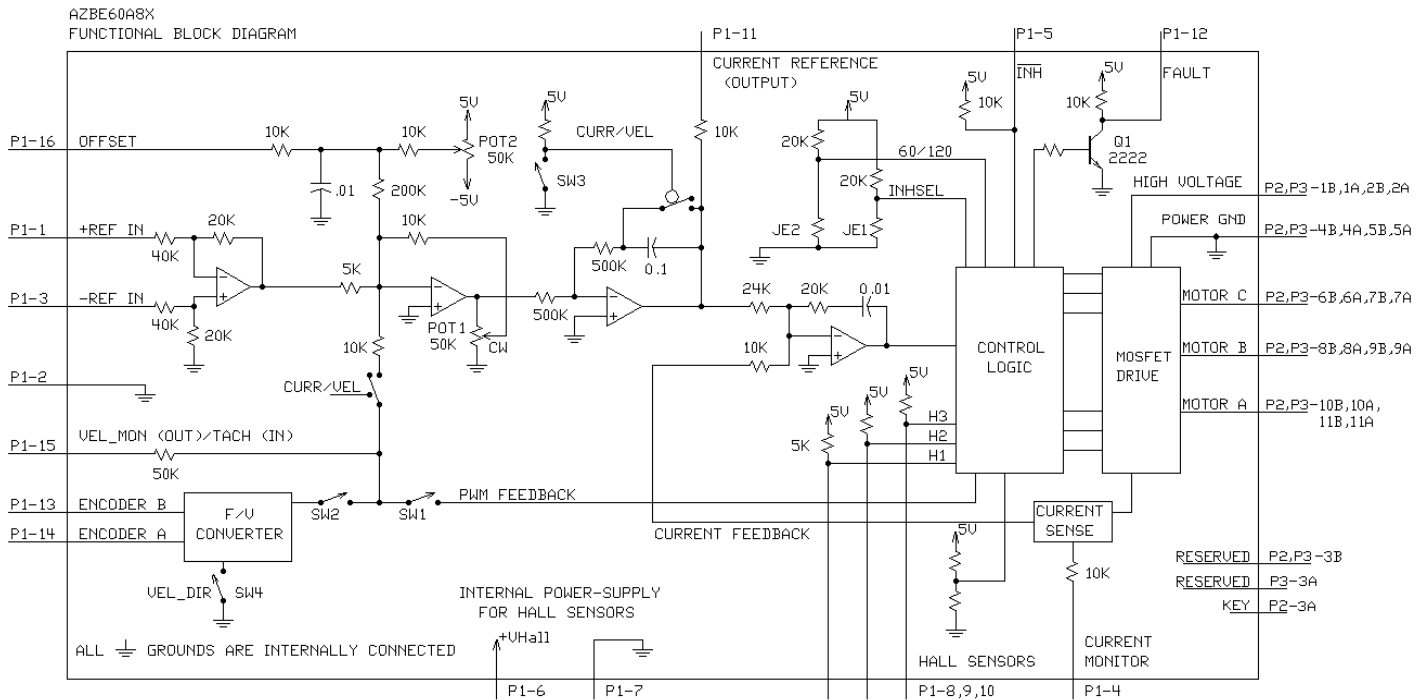
BLOCK DIAGRAM



Information on Approvals and Compliances

| | |
|---|---|
|  | <p>US and Canadian safety compliance with UL 508c, the industrial standard for power conversion electronics. UL registered under file number E140173. Note that machine components compliant with UL are considered UL registered as opposed to UL listed as would be the case for commercial products.</p> |
|  | <p>Compliant with European CE for both the Class A EMC Directive 2004/108/EC on Electromagnetic Compatibility (specifically EN 61000-6-4:2007 and EN 61000-6-2:2005) and LVD requirements of directive 2006/95/EC (specifically EN 60204-1:2006), a low voltage directive to protect users from electrical shock.</p> |
|  | <p>RoHS (Reduction of Hazardous Substances) is intended to prevent hazardous substances such as lead from being manufactured in electrical and electronic equipment.</p> |

SPECIFICATIONS

| Power Specifications | | |
|---|---------|---|
| Description | Units | Value |
| DC Supply Voltage Range | VDC | 10 - 80 |
| DC Bus Over Voltage Limit | VDC | 88 |
| DC Bus Under Voltage Limit | VDC | 9 |
| Maximum Peak Output Current ¹ | A | 60 |
| Maximum Continuous Output Current | A | 30 |
| Maximum Continuous Output Power | W | 2280 |
| Maximum Power Dissipation at Continuous Current | W | 120 |
| Minimum Load Inductance (Line-To-Line) ² | µH | 100 |
| Low Voltage Supply Outputs | - | +6 VDC (30 mA) |
| Switching Frequency | kHz | 33 |
| Control Specifications | | |
| Description | Units | Value |
| Command Sources | - | ±10 V Analog |
| Feedback Supported | - | Halls, Incremental Encoder, Tachometer (± 60 VDC) |
| Commutation Methods | - | Trapezoidal |
| Modes of Operation | - | Current, Encoder Velocity, Duty Cycle, Tachometer Velocity |
| Motors Supported | - | Three Phase (Brushless), Single Phase (Brushed, Voice Coil, Inductive Load) |
| Hardware Protection | - | Invalid Commutation Feedback, Over Current, Over Temperature, Over Voltage, Under Voltage, Short Circuit (Phase-Phase & Phase-Ground) |
| Mechanical Specifications | | |
| Description | Units | Value |
| Agency Approvals | - | CE Class A (EMC), CE Class A (LVD), cUL, RoHS, UL |
| Size (H x W x D) | mm (in) | 76.2 x 50.8 x 22.9 (3 x 2 x 0.9) |
| Weight | g (oz) | 120 (4.23) |
| Heatsink (Base) Temperature Range ³ | °C (°F) | 0 - 75 (32 - 167) |
| Storage Temperature Range | °C (°F) | -40 - 85 (-40 - 185) |
| Form Factor | - | PCB Mounted |
| P1 Connector | - | 16-pin, 2.54 mm spaced header |
| P2 Connector | - | 22-pin, 2.54 mm spaced, dual-row header |
| P3 Connector | - | 22-pin, 2.54 mm spaced, dual-row header |

Notes

1. Maximum duration of peak current is ~2 seconds. Peak RMS value must not exceed continuous current rating of the drive.
2. Lower inductance is acceptable for bus voltages well below maximum. Use external inductance to meet requirements.
3. Additional cooling and/or heatsink may be required to achieve rated performance.

PIN FUNCTIONS

| P1 - Signal Connector | | | |
|-----------------------|---------------------------|--|-----|
| Pin | Name | Description / Notes | I/O |
| 1 | +REF IN | Differential Reference Input (± 10 V Operating Range, ± 15 V Maximum Input) | I |
| 2 | SIGNAL GND | Signal Ground | GND |
| 3 | -REF IN | Differential Reference Input (± 10 V Operating Range, ± 15 V Maximum Input) | I |
| 4 | CURRENT MONITOR | Current Monitor. Analog output signal proportional to the actual current output. Scaling is 20 A/V. Measure relative to signal ground. | O |
| 5 | INHIBIT IN | TTL level (+5 V) inhibit/enable input. Leave open to enable drive. Pull to ground to inhibit drive. Inhibit turns off all power devices. | I |
| 6 | +V HALL OUT | Low Power Supply For Hall Sensors (+6 V @ 30 mA). Referenced to signal ground. Short circuit protected. | O |
| 7 | SIGNAL GND | Signal Ground | GND |
| 8 | HALL 1 | Single-ended Hall/Commutation Sensor Inputs (+5 V logic level) | I |
| 9 | HALL 2* | | I |
| 10 | HALL 3 | | I |
| 11 | CURRENT REFERENCE | Measures the command signal to the internal current-loop. This pin has a maximum output of ± 7.2 V when the drive outputs maximum peak current. Measure relative to signal ground. | O |
| 12 | FAULT OUT | TTL level (+5 V) output becomes high when power devices are disabled due to at least one of the following conditions: inhibit, invalid Hall state, output short circuit, over voltage, over temperature, power-up reset. | O |
| 13 | ENCODER-B IN | Single-ended encoder channel B input. +5 V logic level. | I |
| 14 | ENCODER-A IN | Single-ended encoder channel A input. +5 V logic level. | I |
| 15 | VEL MONITOR OUT / TACH IN | Velocity Monitor. Analog output proportional to motor speed. In Encoder Velocity mode, output is proportional to the encoder line frequency. Encoder Velocity scaling is 22 kHz/V. For Tachometer Velocity mode, feedback voltage range is ± 60 VDC max. | O/I |
| 16 | OFFSET | Connection to external resistance for command offset adjustments. Apply a \pm VDC (10V Max) signal through an external potentiometer into this pin to offset the input gain. | I |

| P2 and P3 - Power Connector | | | | |
|-----------------------------|------|---|--|-----|
| Pin | Name | Description / Notes | I/O | |
| 1b | 1a | DC Power Input. 3A Continuous Current Rating Per Pin. Requires at least 470 μ F / 100 V external electrolytic capacitor connected as close as possible to pins between High Voltage and Power Ground. | I | |
| 2b | 2a | | I | |
| 3b | NC | Not Connected (Reserved) | - | |
| | 3a | Key: No Connection (pin removed) for P2. Not Connected (Reserved) for P3. | - | |
| 4b | 4a | | Power Ground (Common With Signal Ground). 3A Continuous Current Rating Per Pin | GND |
| 5b | 5a | GND | | |
| 6b | 6a | O | | |
| 7b | 7a | O | | |
| 8b | 8a | O | | |
| 9b | 9a | O | | |
| 10b | 10a | O | | |
| 11b | 11a | O | | |
| | | Motor Phase Outputs. Current output distributed equally across both P2 and P3 connectors – 8 pins per motor phase. At ambient temperatures above 50°C, 3A continuous current carrying capacity per pin. At 25°C ambient, 6A continuous current carrying capacity per pin. | | O |
| | | | | O |

*For use with Single Phase (Brushed) motors, ground Hall 2 and only connect motor leads to Motor A and Motor B.

HARDWARE SETTINGS

Switch Functions

| Switch | Description | Setting | |
|--------|--|-----------------|-------------|
| | | On | Off |
| 1 | Duty Cycle mode selector. Activates internal PWM feedback. | Duty Cycle mode | Other modes |
| 2 | Activate velocity feedback or monitor. For Encoder Velocity mode, activates feedback. For Current mode, activates velocity monitor. | Active | Inactive |
| 3 | Current mode selector. | Current mode | Other modes |
| 4 | Velocity feedback polarity. Changes the polarity of the internal feedback signal and the velocity monitor output signal. Inversion of the feedback polarity may be required to prevent a motor run-away condition. | Standard | Inverted |

Mode Selection Table

| | SW1 | SW2 | SW3 |
|---------------------|-----|--------|-----|
| CURRENT | OFF | ON/OFF | ON |
| DUTY CYCLE | ON | OFF | OFF |
| ENCODER VELOCITY* | OFF | ON | OFF |
| TACHOMETER VELOCITY | OFF | OFF | OFF |

*NOTE: See details of switch 4 for further Encoder Velocity configuration information.

Jumper Settings

Jumpers are SMT, 0 ohm resistors located on the underside of the drive PCB. By default, the drive is configured with the jumpers installed. Typical drive operation will not require the jumpers to be removed. Please contact the factory before jumper removal.

| Jumper | Description SMT Jumper (0Ω Resistor) | Configuration | |
|--------|---|---------------|-------------|
| | | Not Installed | Installed |
| JE1 | Inhibit logic. Sets the logic level of inhibit pins. Labeled JE1 on the PCB of the drive. | Low Enable | Low Inhibit |
| JE2 | Hall sensor phasing. Selects 120 or 60 degree commutation phasing. Labeled JE2 on the PCB of the drive. | 60 degree | 120 degree |

Potentiometer Functions

Potentiometers are located between the PCB and the drive baseplate, and are accessible from the side. Potentiometers are approximately linear and have 12 active turns with 1 inactive turn on each end.

| Potentiometer | Description | Turning CW |
|---------------|--|--------------------------------------|
| 1 | Loop gain adjustment for duty cycle / velocity modes. Turn this pot fully CCW in current mode. Located closest to the corner of the PCB. | Increases gain |
| 2 | Offset. Used to adjust any imbalance in the input signal or in the amplifier. Located furthest from the corner of the PCB. | Adjusts offset in negative direction |

MECHANICAL INFORMATION

P1 - Signal Connector

| | | |
|-----------------------|---------------------|-------------------------------|
| Connector Information | | 16-pin, 2.54 mm spaced header |
| Mating Connector | Details | Samtec: BCS-116-L-S-PE |
| | Included with Drive | No |

P2 - Power Connector

| | | |
|-----------------------|---------------------|---|
| Connector Information | | 22-pin, 2.54 mm spaced, dual-row header |
| Mating Connector | Details | Samtec: SSM-111-L-DV |
| | Included with Drive | No |

P3 - Power Connector

| | | |
|-----------------------|---------------------|---|
| Connector Information | | 22-pin, 2.54 mm spaced, dual-row header |
| Mating Connector | Details | Samtec: SSM-111-L-DV |
| | Included with Drive | No |

MOUNTING DIMENSIONS

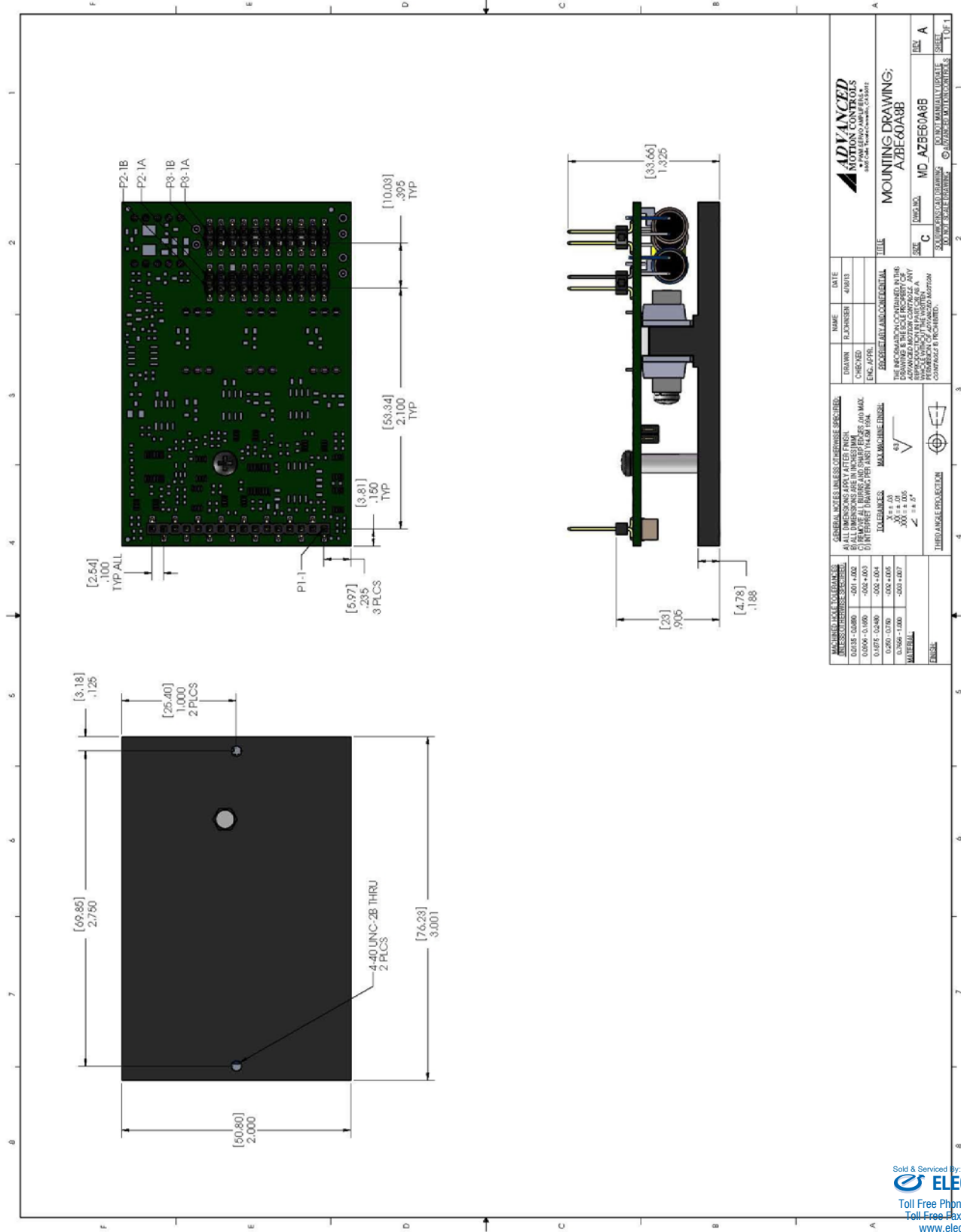

PART NUMBERING INFORMATION

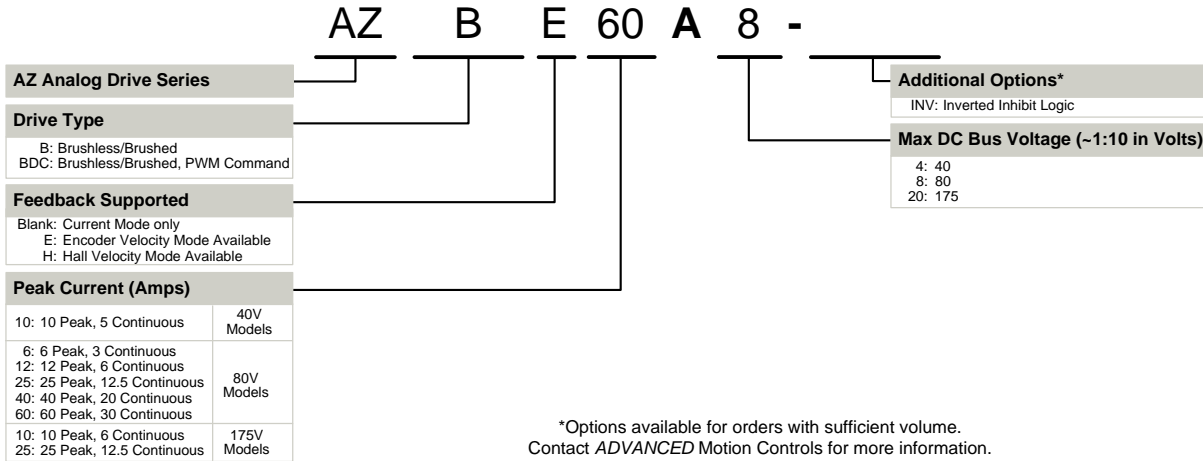

ADVANCED Motion Controls AZ series of servo drives are available in many configurations. Note that not all possible part number combinations are offered as standard drives. All models listed in the selection tables of the website are readily available, standard product offerings.

ADVANCED Motion Controls also has the capability to promptly develop and deliver specified products for OEMs with volume requests. Our Applications and Engineering Departments will work closely with your design team through all stages of development in order to provide the best servo drive solution for your system. Equipped with on-site manufacturing for quick-turn customs capabilities, ADVANCED Motion Controls utilizes our years of engineering and manufacturing expertise to decrease your costs and time-to-market while increasing system quality and reliability.

Examples of Modifications and Customized Products

- | | |
|---|--|
| <ul style="list-style-type: none"> ▲ Integration of Drive into Motor Housing ▲ Mount OEM PCB onto Drive Without Cables ▲ Multi-axis Configuration for Compact System ▲ Custom PCB and Baseplate for Optimized Footprint ▲ RTV/Epoxy Components for High Vibration ▲ OEM Specified Connectors for Instant Compatibility ▲ OEM Specified Silkscreen for Custom Appearance ▲ Increased Thermal Limits for High Temp. Operation | <ul style="list-style-type: none"> ▲ Integrate OEM Circuitry onto Drive PCB ▲ Custom Control Loop Tuned to Motor Characteristics ▲ Custom I/O Interface for System Compatibility ▲ Preset Switches and Pots to Reduce User Setup ▲ Optimized Switching Frequency ▲ Ramped Velocity Command for Smooth Acceleration ▲ Remove Unused Features to Reduce OEM Cost ▲ Application Specific Current and Voltage Limits |
|---|--|

Feel free to contact Applications Engineering for further information and details.

Available Accessories

ADVANCED Motion Controls offers a variety of accessories designed to facilitate drive integration into a servo system. Visit www.a-m-c.com to see which accessories will assist with your application design and implementation.

