

Description

The PFC2400W375 is a regulated DC power supply designed to feed 400V series servo drives with a low noise 375 VDC bus. Universal single-phase AC input 86-264 VAC / 50-60 Hz with power factor correction and low harmonic distortion along with soft starting circuitry guarantees global high performance reliable operation. These AC/DC converters are superior to conventional power supplies as they meet the specific needs of high dynamic and precision motor drives.

Power Range

Input Voltage	100 - 240 VAC
Output Voltage	375 VDC

**Features**

- ▲ AC Line Harmonic Independent Power Factor Correction
- ▲ AC Line Voltage and Frequency Monitoring and Protection
- ▲ Medical Grade I/O Isolation and Chassis Leakage Current Rating
- ▲ Line Voltage Surge and Lightning Protection
- ▲ Automatic and Forced Shunt Resistor Switch
- ▲ Double Line Fused for Split Single-Phase Services
- ▲ High Efficiency and Power Factor even at Low Line and Loads
- ▲ Soft Start Pre-charging Circuitry to Limit the Inrush Current
- ▲ Filtered Auxiliary AC Outlet for Ancillary System Loads
- ▲ Fault Status Logic Output for Power Sequencing
- ▲ Over Voltage, Over Current, Over Temperature Protections

Sold & Serviced By:



Canadian and International Sales

ELECTROMATE

877-737-8698

sales@electromate.com

www.electromate.com

U.S. Sales

SERVO2GO.com

877-378-0240

sales@servo2go.com

www.servo2go.com

BLOCK DIAGRAM

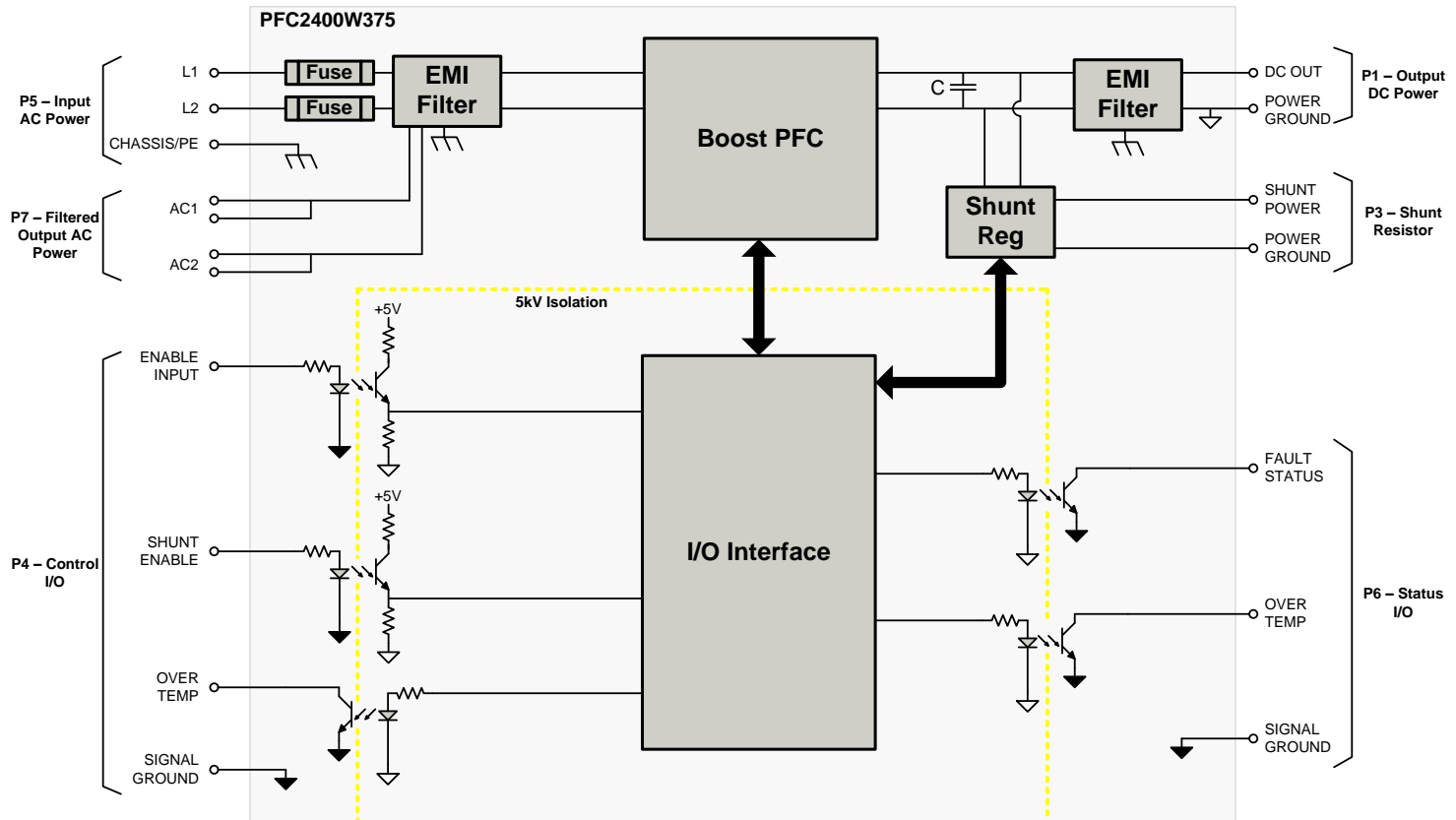

Sold & Serviced By:



Canadian and International Sales

ELECTROMATE

877-737-8698

sales@electromate.com

www.electromate.com

U.S. Sales



877-378-0240

sales@servo2go.com

www.servo2go.com

SPECIFICATIONS



Warning! Hazardous voltage (400V). Contact may cause electrical shock and injury. Devices on this system store electrical energy. Remove power and wait for 5 minutes, and verify all devices are discharged before servicing.

Power Specifications	
Description	Value
Nominal AC Input Range	100 – 240 VAC
Minimum AC Input	86 VAC
Maximum AC Input	264 VAC
Input Surge	290 VAC / 1s
Input Frequency	50/60 Hz (±5%)
Total Harmonic Distortion	10% Max (>250W)
Inrush and Input Current Limit	I _{max} < 12 Arms
Power Factor	.96 @ 250 Watts, up to .99 @ >250 Watts
Output Voltage	375 VDC steady state (±3)
Assembly Overvoltage	415 VDC typical
Continuous DC Output Current	3.2ADC @ 120VAC Input; 6.4ADC @ 240VAC Input
Peak DC Output Current ¹	6.4ADC @ 120VAC Input; 12.8ADC @ 240VAC Input
Input Power Rating	1.2kW @ 120VAC Input; 2.4kW @ 240VAC Input
Input Fuses	2 x 12.5 A 250 VAC Cartridge Fuse 5x20 mm, time-delay fuse
Shunt Resistor Fuse	1 x .315 ADC Cartridge Fuse
RMS Power to Shunt Resistor	Capable of 120W through direct connection to the DC bus through a switch, activated either automatically at 390 VDC or by the shunt input control signal.
Ground/Chassis Leakage Current	<180µA @ 240VAC/60Hz
Efficiency	1.2kW @ 120V/60Hz: 93.3%; 1.2kW @ 240VAC/50Hz: 97%



Control Specifications	
Description	Value
Digital Input Logic Levels	5V (±10%)
Max Voltage Level for Open Drain Digital Outputs	28V

Mechanical Specifications	
Description	Value
Agency Approvals	CE, RoHS II, UL
Baseplate Temperature Operating Range	0 – 95 °C (32 – 203 °F)
Size (H x W x D)	248.4 x 203.2 x 79.0 mm (9.78 x 8.00 x 3.11 in)

Notes

1. For peak times >1s, the output DC voltage tolerance may be increased.

Information on Approvals and Compliances

	US and Canadian safety compliance with UL/IEC 61800-5-1. UL registered under file number E140173. Note that machine components compliant with UL are considered UL registered as opposed to UL listed as would be the case for commercial products.
	IEC 61800-5-3/CISPR 11 Class A for Conducted and Radiated Emissions
	The RoHS II Directive 2011/65/EU restricts the use of certain substances including lead, mercury, cadmium, hexavalent chromium and halogenated flame retardants PBB and PBDE in electronic equipment.

PIN FUNCTIONS

P1 – Output DC Power Connector		
Pin	Name	Description / Notes
1	DC OUT	375 VDC Bus output from the PFC
2	POWER GROUND	Power Ground

P3 – Shunt Resistor Connector		
Pin	Name	Description / Notes
1	SHUNT POWER	DC Bus output to external shunt resistor. Turn-on voltage is 390 VDC.
2	POWER GROUND	Power Ground

P4 – Control I/O Connector		
Pin	Name	Description / Notes
1	ENABLE/DISABLE INPUT	Digital Input, active high – does not activate a fault
2	SHUNT ENABLE/DISABLE	Digital Input, active high
3	OVER TEMPERATURE FAULT	Digital Output (Open Collector), active low
4	SIGNAL GROUND	Signal Ground

P5 – Input AC Power Connector		
Pin	Name	Description / Notes
1	L1	100-240 Single Phase VAC Input
2	CHASSIS/PE	Chassis Ground / PE
3	L2	100-240 Single Phase VAC Input

P6 – Status I/O Connector		
Pin	Name	Description / Notes
1	FAULT STATUS OUTPUT	Digital Output (Open Collector), active low, goes high when PFC disabled, pre-charging, or faulted. See Pin Details below.
2	OVER TEMPERATURE FAULT	Digital Output (Open Collector), active low
3	SIGNAL GROUND	Signal Ground

P7 – Filtered Output AC Power Connector*		
Pin	Name	Description / Notes
1	AC1	AC Output L1, between the two on-board line filters
2	AC1	
3	AC2	AC Output L2, between the two on-board line filters
4	AC2	

*This connector provides filtered power to the rest of the AC loads in the system. The combined continuous load current for this connector and the PFC shall not exceed 80% of the input fuse rating of the PFC.

Pin Details
FAULT STATUS OUTPUT (P6-1)

Load (enabling servo drive) can be applied only when Fault Status signal goes low (open collector). In case of a fault, this signal goes high (impedance) requiring the load to be disconnected (servo drive inhibited). PFC will usually be ready for loading within approximately 5s after power-up, depending on line status and the drive's total capacitance attached to its output.

HARDWARE INFORMATION
Status LED Functions

LEDs are bi-color RED/GREEN.

LED	Description	
1	GREEN: PFC Running	RED: PFC Standby
2	GREEN: PFC Analog Supply Normal	RED: PFC Digital Supply Normal
3	GREEN: PFC Bus Stabilized, Servo Drive Enabled	RED: PFC Over Temperature Fault

MECHANICAL INFORMATION

P1 – Output DC Power Connector

Connector Information		Molex: P/N 76829-0002; Wire-to-Board Connector, 5.7mm, 2 contacts, Header, Mega-Fit
Mating Connector	Details	Molex: P/N 171692-0102 (Mega-Fit Receptacle Housing, Dual Row) and P/N 1720630311 (crimp pins)
	Included with Drive	Yes

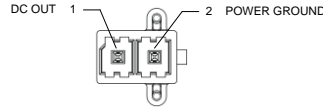

P3 – Shunt Resistor Connector

Connector Information		Molex: P/N 39-28-8020; Mini-Fit Jr.™ Vertical Header, 4.20mm pitch, Dual Row
Mating Connector	Details	Molex: P/N 39-01-2025 (Mini-Fit Jr.™ Receptacle Housing, Dual Row) and P/N 45750-1111 (crimp pins)
	Included with Drive	No

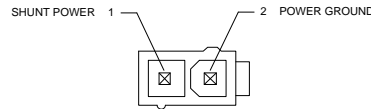

P4 – Control I/O Connector

Connector Information		Molex: P/N 43650-0428; Micro-Fit 3.0™ Vertical Header, 3.00mm pitch, Single Row
Mating Connector	Details	Molex: P/N 43645-0400 (Micro-Fit 3.0™ Receptacle Housing, Single Row) and P/N 43030-0002 (crimp pins)
	Included with Drive	No

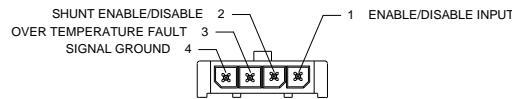

P5 – Input AC Power Connector

Connector Information		Molex: P/N 10-84-5030; MLX™ Power Connector Vertical Header, 6.35mm pitch
Mating Connector	Details	Molex: P/N 50-84-1030 (MLX™ Power Crimp Housing) and P/N 02-08-2003 (crimp pins)
	Included with Drive	No

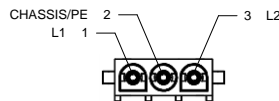

P6 – Status I/O Connector

Connector Information		Molex: P/N 43650-0328; Micro-Fit 3.0™ Vertical Header, 3.00mm pitch, Single Row
Mating Connector	Details	Molex: P/N 43645-0300 (Micro-Fit 3.0™ Receptacle Housing, Single Row) and P/N 43030-0002 (crimp pins)
	Included with Drive	No

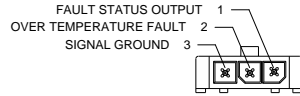

P7 – Filtered Output AC Power Connector

Connector Information		Molex: P/N 10-84-5040; MLX™ Power Connector Vertical Header, 6.35mm pitch
Mating Connector	Details	Molex: P/N 50-84-1040 (MLX™ Power Crimp Housing) and P/N 02-08-2003 (crimp pins)
	Included with Drive	No

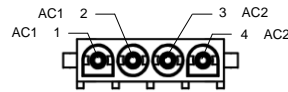

Sold & Serviced By:

Canadian and International Sales

ELECTROMATE
 877-737-8698
 sales@electromate.com
 www.electromate.com

U.S. Sales

SERVO2GO.com
 877-378-0240
 sales@servo2go.com
 www.servo2go.com

MOUNTING DIMENSIONS

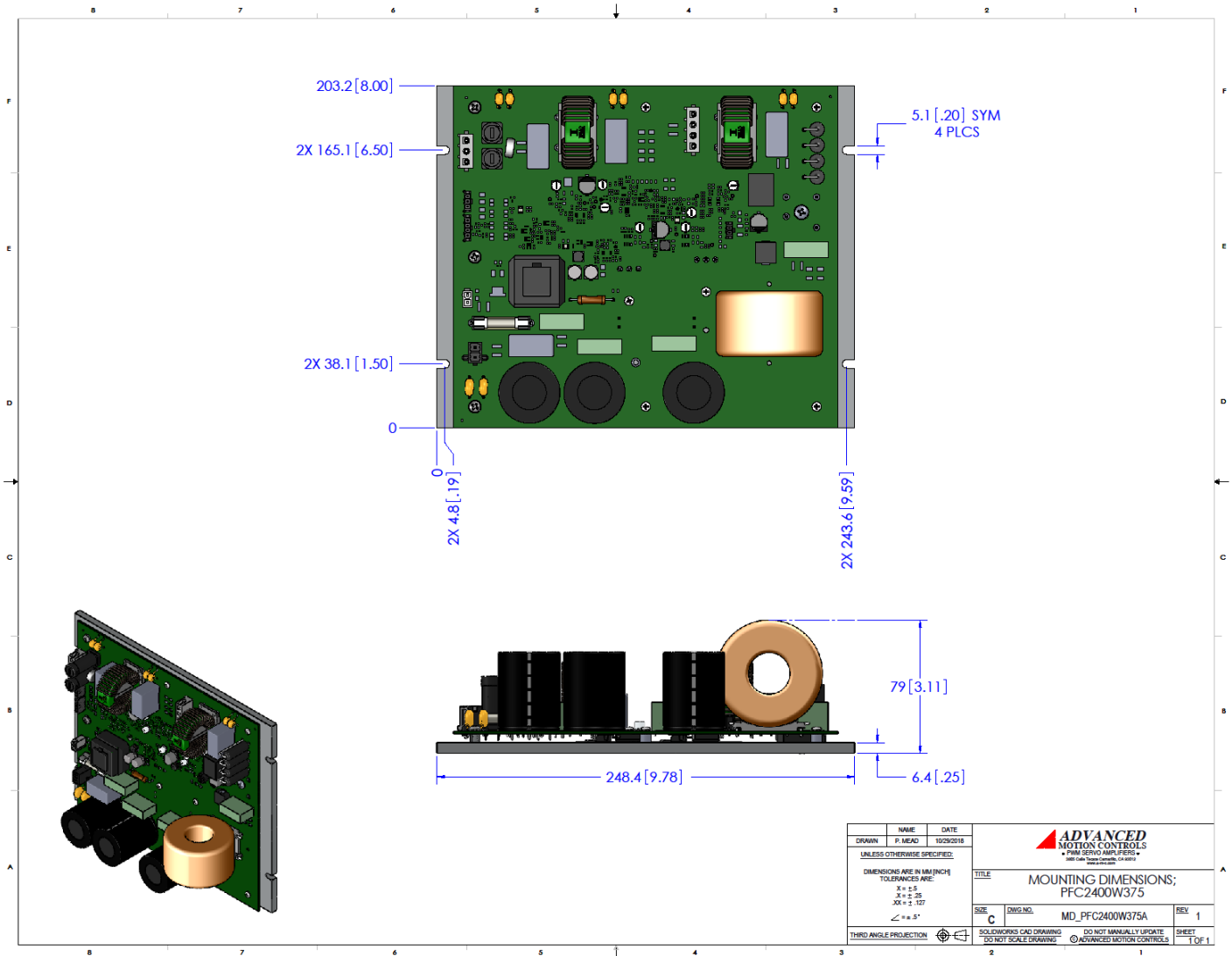

NAME	DATE	 ADVANCED MOTION CONTROLS P.W.M. SERVO AMPLIFIERS 2400 WATT 10000 RPM	
DRAWN	P. MEAD		
UNLESS OTHERWISE SPECIFIED:			TITLE
DIMENSIONS ARE IN MM (INCH)			MOUNTING DIMENSIONS; PFC2400W375
TOLERANCES ARE:			SIZE
.3X ± .05			C
.6X ± .10			DWG. NO.
.X ± .127			MD_PFC2400W375A
∠ ± .5°			REV
THIRD ANGLE PROJECTION			1
SOLIDWORKS CAD DRAWING			SHEET
DO NOT MANUALLY UPDATE			1 OF 1
DO NOT SCALE DRAWING			
© ADVANCED MOTION CONTROLS			

Sold & Serviced By:



Canadian and International Sales

ELECTROMATE

877-737-8698
sales@electromate.com
www.electromate.com

U.S. Sales



877-378-0240
sales@servo2go.com
www.servo2go.com