

ELECTRIC ACTUATORS

engineered for long life with

ENDURANCE TECHNOLOGYSM



LINEAR SOLUTIONS MADE EASY

Sold & Serviced By:

ELECTROMATE

Toll Free Phone (877) SERV098

Toll Free Fax (877) SERV099

www.electromate.com





sales@electromate.com

SELECT THE ACTUATOR

RODLESS STYLE SCREW ACTUATORS

	MXE-S <i>Solid bearing design to accommodate moderate load carrying and guidance applications</i>	MAX. LOAD	MAX. THRUST	MAX. SPEED	MAX. STROKE
PAGE 6		1,040 lb 4,626 N	4,300 lbf 19,127 N	60 in/sec 1,524 mm/sec	178 in 4,521 mm
	MXE-P <i>Recirculating ball linear bearings support moderate to heavy load and moment applications</i>	MAX. LOAD	MAX. THRUST	MAX. SPEED	MAX. STROKE
PAGE 8		2,583 lb 11,490 N	4,300 lbf 19,127 N	60 in/sec 1,524 mm/sec	178 in 4,521 mm
	B3S <i>Internal recirculating ball bearing design to fully support moderate to heavy loads and moments</i>	MAX. LOAD	MAX. THRUST	MAX. SPEED	MAX. STROKE
PAGE 10 (M3S, B3SD, M3SD)		8,032 lb 35,728 N	2,700 lbf 12,010 N	60 in/sec 1,524 mm/sec	179 in 4,547 mm
	TKS <i>Table style actuator with the highest accuracy, flatness and straightness specifications</i>	MAX. LOAD	MAX. THRUST	MAX. SPEED	MAX. STROKE
PAGE 12		1,500 lb 6,672 N	3,260 lbf 14,501 N	60 in/sec 1,524 mm/sec	96 in 2,438 mm

RODLESS STYLE BELT ACTUATORS

	MXB-U <i>Pre-assembled compact linear belt solution for use in applications with existing guides & supports</i>	MAX. LOAD	MAX. THRUST	MAX. SPEED	MAX. STROKE
PAGE 14		—	418 lbf 1,859 N	200 in/sec 5,080 mm/sec	230 in 5,842 mm
	MXB-P <i>Recirculating ball linear bearings support moderate to heavy load and moment applications</i>	MAX. LOAD	MAX. THRUST	MAX. SPEED	MAX. STROKE
PAGE 16		2,583 lb 11,490 N	418 lbf 1,859 N	150 in/sec 3,810 mm/sec	230 in 5,842 mm
	B3W <i>Internal belt with the same bearing design as B3S, supporting high speed and long stroke applications</i>	MAX. LOAD	MAX. THRUST	MAX. SPEED	MAX. STROKE
PAGE 18 (M3W, B3WD, M3WD)		8,032 lb 35,728 N	325 lbf 1,446 N	200 in/sec 5,080 mm/sec	292 in 7,417 mm
	TKB <i>Table style actuator with the highest accuracy, flatness and straightness specifications</i>	MAX. LOAD	MAX. THRUST	MAX. SPEED	MAX. STROKE
PAGE 20		1,500 lb 6,672 N	245 lbf 1,090 N	100 in/sec 2,540 mm/sec	96 in 2,438 mm

NOTE: Actuators may not deliver ALL the maximum ratings in one application; (e.g., maximum speed is generally not recommended with maximum load)

Sold & Serviced By:

 **ELECTROMATE**

Toll Free Phone (877) SERV098

Toll Free Fax (877) SERV099

www.electromate.com

sales@electromate.com

STYLE YOU NEED...

ROD STYLE SCREW ACTUATORS

	<p>ERD</p> <p>PAGE 22</p>	<p><i>Economical rod-style electric actuator with solid nut/screw in a compact package</i></p> <table border="1"> <thead> <tr> <th>MAX. LOAD</th> <th>MAX. THRUST</th> <th>MAX. SPEED</th> <th>MAX. STROKE</th> </tr> </thead> <tbody> <tr> <td>—</td> <td>4,500 lbf</td> <td>40 in/sec</td> <td>24 in</td> </tr> <tr> <td>—</td> <td>20,017 N</td> <td>1,016 mm/sec</td> <td>610 mm</td> </tr> </tbody> </table>	MAX. LOAD	MAX. THRUST	MAX. SPEED	MAX. STROKE	—	4,500 lbf	40 in/sec	24 in	—	20,017 N	1,016 mm/sec	610 mm
MAX. LOAD	MAX. THRUST	MAX. SPEED	MAX. STROKE											
—	4,500 lbf	40 in/sec	24 in											
—	20,017 N	1,016 mm/sec	610 mm											
	<p>ICR</p> <p>PAGE 24</p>	<p><i>Integral motor controller design with ball screw for medium force applications in a compact package</i></p> <table border="1"> <thead> <tr> <th>MAX. LOAD</th> <th>MAX. THRUST</th> <th>MAX. SPEED</th> <th>MAX. STROKE</th> </tr> </thead> <tbody> <tr> <td>—</td> <td>720 lbf</td> <td>25 in/sec</td> <td>24 in</td> </tr> <tr> <td>—</td> <td>3,203 N</td> <td>635 mm/sec</td> <td>609 mm</td> </tr> </tbody> </table>	MAX. LOAD	MAX. THRUST	MAX. SPEED	MAX. STROKE	—	720 lbf	25 in/sec	24 in	—	3,203 N	635 mm/sec	609 mm
MAX. LOAD	MAX. THRUST	MAX. SPEED	MAX. STROKE											
—	720 lbf	25 in/sec	24 in											
—	3,203 N	635 mm/sec	609 mm											
	<p>RSA (RSM)</p> <p>PAGE 26</p>	<p><i>Traditional pneumatic or hydraulic cylinder style operation for externally supported and guided loads</i></p> <table border="1"> <thead> <tr> <th>MAX. LOAD</th> <th>MAX. THRUST</th> <th>MAX. SPEED</th> <th>MAX. STROKE</th> </tr> </thead> <tbody> <tr> <td>—</td> <td>7,350 lbf</td> <td>123 in/sec</td> <td>60 in</td> </tr> <tr> <td>—</td> <td>32,695 N</td> <td>3,124 mm/sec</td> <td>1,524 mm</td> </tr> </tbody> </table>	MAX. LOAD	MAX. THRUST	MAX. SPEED	MAX. STROKE	—	7,350 lbf	123 in/sec	60 in	—	32,695 N	3,124 mm/sec	1,524 mm
MAX. LOAD	MAX. THRUST	MAX. SPEED	MAX. STROKE											
—	7,350 lbf	123 in/sec	60 in											
—	32,695 N	3,124 mm/sec	1,524 mm											
	<p>GSA (GSM)</p> <p>PAGE 28</p>	<p><i>Self-contained guided cylinder style operation for loads requiring guidance and support</i></p> <table border="1"> <thead> <tr> <th>MAX. LOAD</th> <th>MAX. THRUST</th> <th>MAX. SPEED</th> <th>MAX. STROKE</th> </tr> </thead> <tbody> <tr> <td>1,200 lb</td> <td>2,700 lbf</td> <td>123 in/sec</td> <td>36 in</td> </tr> <tr> <td>5,338 N</td> <td>12,010 N</td> <td>3,124 mm/sec</td> <td>914 mm</td> </tr> </tbody> </table>	MAX. LOAD	MAX. THRUST	MAX. SPEED	MAX. STROKE	1,200 lb	2,700 lbf	123 in/sec	36 in	5,338 N	12,010 N	3,124 mm/sec	914 mm
MAX. LOAD	MAX. THRUST	MAX. SPEED	MAX. STROKE											
1,200 lb	2,700 lbf	123 in/sec	36 in											
5,338 N	12,010 N	3,124 mm/sec	914 mm											
	<p>IMA</p> <p>PAGE 30</p>	<p><i>Integral motor design with roller or ball screw for high force applications in a compact package</i></p> <table border="1"> <thead> <tr> <th>MAX. LOAD</th> <th>MAX. THRUST</th> <th>MAX. SPEED</th> <th>MAX. STROKE</th> </tr> </thead> <tbody> <tr> <td>—</td> <td>6,875 lbf</td> <td>52.5 in/sec</td> <td>18 in</td> </tr> <tr> <td>—</td> <td>30,594 N</td> <td>1,334 mm/sec</td> <td>457 mm</td> </tr> </tbody> </table>	MAX. LOAD	MAX. THRUST	MAX. SPEED	MAX. STROKE	—	6,875 lbf	52.5 in/sec	18 in	—	30,594 N	1,334 mm/sec	457 mm
MAX. LOAD	MAX. THRUST	MAX. SPEED	MAX. STROKE											
—	6,875 lbf	52.5 in/sec	18 in											
—	30,594 N	1,334 mm/sec	457 mm											

...COMPLETE YOUR SOLUTION

ADD ANY MOTION SYSTEM TO OUR ACTUATOR



CUSTOM MOTOR MOUNTS. 15 DAYS

• Select a high-performance Tolomatic electric actuator and we'll provide a motor-specific interface for your motor. With our online database, you can select from over 60 motor manufacturers and hundreds of models.

Visit www.tolomatic.com/yjh today to find your motor/actuator match!

OR

SELECT A COMPLETE SYSTEM FROM TOLOMATIC



- MOTORS
- DRIVES
- CONTROLLERS
- GEARBOXES

Tolomatic offers digital servo or stepper drives with motors matched to provide optimal performance with Tolomatic actuators.

NOTE: Actuators may not deliver ALL the maximum ratings in one application; (e.g., maximum speed is generally not recommended with maximum load)

Sold & Serviced By:

 **ELECTROMATE**

Toll Free Phone (877) SERV098

Toll Free Fax (877) SERV099

www.electromate.com

sales@electromate.com

DEDICATED TO LINEAR MOTION SOLUTIONS



Since 1985, with the introduction of our pneumatic rodless band cylinder, Tolomatic has been a market leader for linear motion solutions. In 1992, we introduced screw and belt driven rodless actuators for users demanding solutions controlled by electric motors. Today, Tolomatic's electric product family has grown to include a broad range of rod and rodless style actuators and actuators with integral motors and built-in position sensors. All standard products are built to order and shipped directly to you in 15 days or less! From single actuators to complete systems, turn to Tolomatic for your linear motion solutions.

COMMITTED TO THE HIGHEST QUALITY



Our commitment to quality is legendary. From stringent process controls in our manufacturing facility to the best customer support, we stand behind our products.

ENDURANCE TECHNOLOGYSM

Years of application experience focused on linear actuators means every component and material is designed to produce the best value and best performing actuators in the market today. We call this philosophy Endurance Technology.

APPLICATION: Position, Fill, Assemble

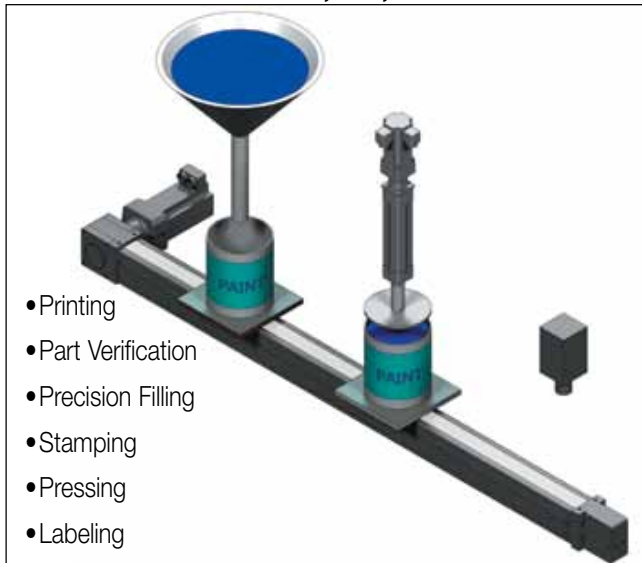

APPLICATION: Gating, Sorting

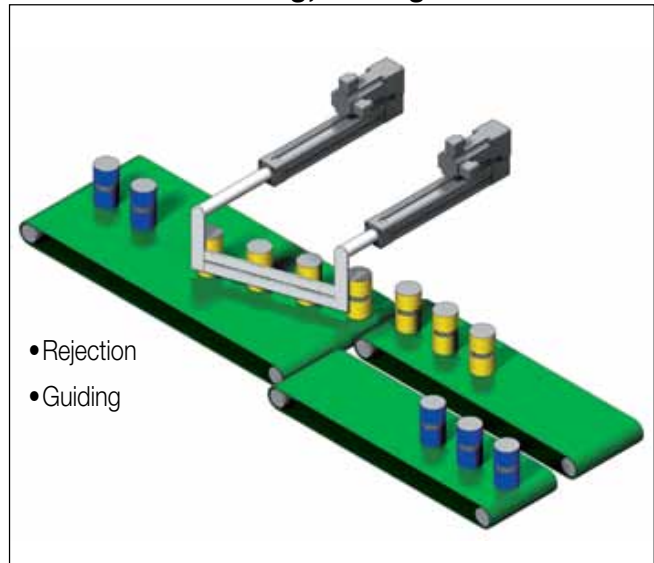

Sold & Serviced By:

 **ELECTROMATE**

Toll Free Phone (877) SERV098

Toll Free Fax (877) SERV099

www.electromate.com

sales@electromate.com

UNDERSTANDING THE DIFFERENCES

ROD ACTUATORS

OPERATING ENVELOPE

The load (or end effector) is able to fully retract out of the work zone, allowing clearance for other operations.

STROKE LENGTH

Stroke length limitations exist due to the mass and support requirements when the actuator thrust tube is extended. A max. stroke length of 5 feet is normal.

LOAD SUPPORT

External load support and guidance is typically required.

SPEED AND THRUST

Installations with a ball or roller screw can provide high forces via the thrust tube.

MASS AND INERTIA

Higher weight and moment of inertia are typical due to the mass of the thrust tube.

RODLESS ACTUATORS

The load and carrier traverse the body of the actuator itself, providing up to 50% space savings when compared to an equivalently sized rod actuator.

Applications requiring longer stroke lengths can easily be accommodated; lengths of 24 feet are available as standard product.

The actuator body supports the load and associated moments; actuator bearing designs accommodate load requirements.

Belt drive rodless actuators are capable of high speeds, up to 200 in/sec. (5m/sec.)

Lower total mass and lower reflected inertia are typical when compared to rod style actuators.

ADVANTAGES OF ELECTRIC ACTUATORS

- Provides precise control of acceleration, speed, position and/or torque
- Accurately positions the load at variable and repeatable locations within the full stroke
- Synchronizes multiple axes for coordinated moves
- Programs or configurations can quickly be changed for multiple applications
- Ability to synchronize with other machine operations
- Quiet, clean and energy efficient operation

APPLICATION: Applying, Dispensing

- Spraying
- Cutting
- Slitting

- Test Fixtures
- Inspection

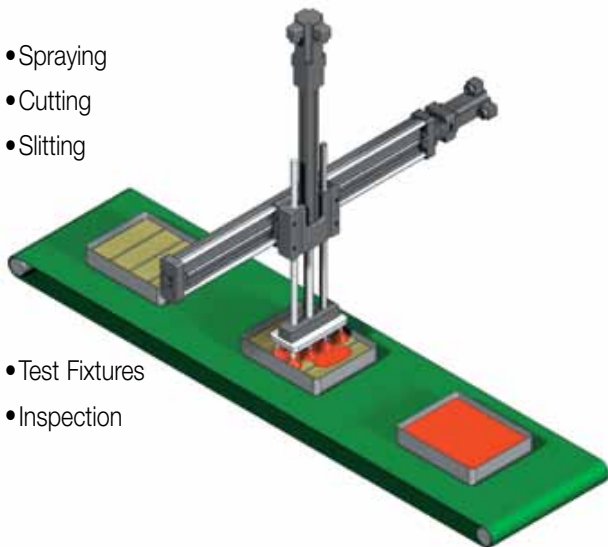

APPLICATION: Storage & Retrieval

- Parts Transfer
- Pick & Place
- Stacking
- Sorting

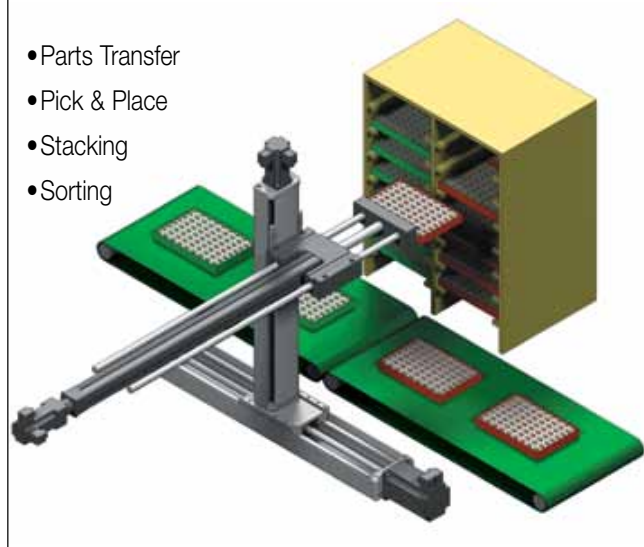

Sold & Serviced By:

 **ELECTROMATE**

Toll Free Phone (877) SERV098

Toll Free Fax (877) SERV099

www.electromate.com

sales@electromate.com

MXE-S SOLID BEARING SCREW ACTUATOR

ENDURANCE TECHNOLOGYSM

Endurance Technology features are designed for maximum durability to provide extended service life.

The MXE-S rodless electric screw-drive actuator is designed for applications requiring moderate load carrying and guidance. The MXE-S actuator utilizes two field replaceable solid bearings that optimize stress distribution for optimal performance. Built-to-order in stroke lengths up to 178 inches.

LIGHTWEIGHT ALUMINUM DESIGN

- Clear anodized extrusion design is optimized for rigidity and strength

STAINLESS STEEL BAND

- Exterior dust band made of fatigue resistant, durable, flexible and corrosion resistant stainless steel

RETAINED DUST BAND

- Retained dust band keeps contaminants from entering the actuator interior, protecting components for reduced maintenance and increased uptime

LARGE FLEXIBLE MOUNTING PATTERN

- Carrier gives more load stability
- Compatibility with existing BCS applications
- More fastening options

DUST WIPER

- Formed end cap and side dust wipers keep contaminants from entering the actuator's internal area

MULTIPLE SCREW TECHNOLOGIES

YOU CAN CHOOSE:

- Solid nuts of engineered resins for quiet performance at the lowest cost - 5 choices
- Ball nuts offer positioning accuracy and repeatability with longer life, low-backlash available - 3 choices



NON-WEAR BAND RETENTION

- Magnetically retained band is not subject to wear as are mechanically retained systems

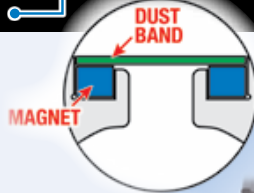

15 DAYS BUILT-TO-ORDER

MXE-S

SPECIFICATIONS: pg. 32
SIZES



MAXIMUM
STROKE: 178"
THRUST: 4,300 lbf
SPEED: 60 in/sec
LOAD: 1,040 lb

Sold & Serviced By:

ELECTROMATE

Toll Free Phone (877) SERV098
Toll Free Fax (877) SERV099
www.electromate.com
sales@electromate.com

• INCH OR METRIC MOUNTING •

- Your choice of inch (US standard) or metric mounting to the carrier

• YOUR MOTOR HERE •

YOU CAN CHOOSE:

- Motor or gearbox supplied and installed by Tolomatic
- Specify the device to be installed and actuator ships with proper mounting hardware - MXE is a "Your Motor Here" actuator for easy in-line motor installation. Check our website (www.tolomatic.com/yhm) for complete YMH information
- Specify and ship your device to Tolomatic for factory installation

• MOTOR ORIENTATION •

YOU CAN CHOOSE:

- In-line option directly couples the driving shaft and is a one-piece housing construction for optimum alignment and support of the motor
- Reverse-parallel option minimizes the overall length and offers a 1:1 or 2:1 belt ratio

• NON-BINDING BEARING ARMS •

- Bearings are tensioned indirectly, providing bind free adjustment

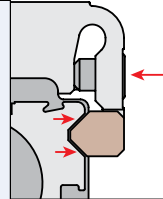

• TRAPEZOIDAL BEARINGS •

- Trapezoidal design maximizes bearing surface area for less pressure on bearing surfaces; less pressure results in less wear
- Engineered bearing material has low static and dynamic friction with low wear properties for long lasting, smooth operation
- Bearings are field replaceable for extended service life

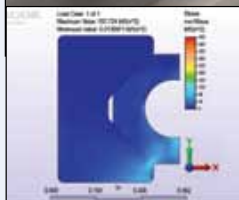

NOTE: Boxed letters indicate ordering codes

OPTIONS



AUXILIARY CARRIER DC

- 2X higher Fz (load) capacity
- High bending moment capacity



FLOATING MOUNT FL

- Compensates for non-parallelism between MX actuator and externally guided load



TUBE CLAMPS TC

- Used for intermediate support
- Flush with bottom of actuator to retain low profile
- Drop-in, adjustable mounting locations (MXE16 uses T-nuts with mounting plates)



MOUNTING PLATES MP

- To provide clearance for motor and mount
- Use in conjunction with tube clamps



SWITCHES

- Wide variety of sensing choices: Reed, Solid State PNP or NPN, all available normally open or normally closed
- Flush mount, drop-in installation
- Bright LEDs, power & signal indication
- CE rated, RoHS compliant

• INTERNAL MAGNETS •

- Standard feature that allows sensor installation on the open side or bottom of the extrusion

Sold & Serviced By:



Toll Free Phone (877) SERV098
Toll Free Fax (877) SERV099
www.electromate.com
sales@electromate.com

MXE-**P** PROFILED RAIL SCREW ACTUATOR

ENDURANCE TECHNOLOGYSM

Endurance Technology features are designed for maximum durability to provide extended service life.

The MXE-P rodless electric screw-drive actuator is designed for applications requiring moderate to heavy load carrying and guidance. The MXE-P actuator features a profiled rail system with recirculating ball linear guides for optimal performance. Built-to-order in stroke lengths up to 178 inches.

DUST WIPER

- Formed end cap and side dust wipers keep contaminants from entering the actuator's internal area

INTERNAL MAGNETS

- Standard feature that allows sensor installation on the open side or bottom of the extrusion

STAINLESS STEEL BAND

- Exterior dust band made of fatigue resistant, durable, flexible and corrosion resistant stainless steel

RECIRCULATING BALL BEARINGS

- Recirculating ball bearings are used to reduce friction and extend actuator life
- Designed with a grease pocket between ball elements to reduce friction, noise and maintenance
- Large permissible moment loads
- High speed operation, low heat generation
- High precision, smooth, low friction motion

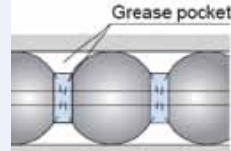

LIGHTWEIGHT ALUMINUM DESIGN

- Clear anodized extrusion design is optimized for rigidity and strength

INCH OR METRIC MOUNTING

- Your choice of inch (US standard) or metric mounting to the carrier

MXE-P

SPECIFICATIONS: pg. 32
SIZES

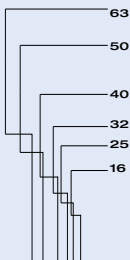

MAXIMUM

STROKE: 178"
THRUST: 4,300 lbf
SPEED: 60 in/sec
LOAD: 2,583 lb

Sold & Serviced By:

ELECTROMATE

Toll Free Phone (877) SERV098
Toll Free Fax (877) SERV099
www.electromate.com
sales@electromate.com

• LOW CARRIER HEIGHT •

- Reduces overall actuator envelope
- Large mounting pattern for excellent load stability

• YOUR MOTOR HERE •

YOU CAN CHOOSE:

- Motor or gearbox supplied and installed by Tolomatic
- Specify the device to be installed and actuator ships with proper mounting hardware - MXE is a "Your Motor Here" actuator for easy in-line motor installation. Check our website (www.tolomatic.com/yjh) for complete information
- Specify and ship your device to Tolomatic for factory installation

• MOTOR ORIENTATION •

YOU CAN CHOOSE:

- In-line option directly couples the driving shaft and is a one-piece housing construction for optimum alignment and support of the motor
- Reverse-parallel option minimizes the overall length and offers a 1:1 or 2:1 belt ratio

• NON-WEAR BAND RETENTION •

- Magnetically retained band is not subject to wear as are mechanically retained systems
- Immediate band engagement and release results in less drag on carrier for lower friction force during initial carrier movement

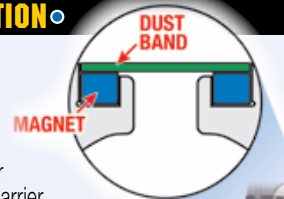

• RETAINED DUST BAND •

- Retained dust band keeps contaminants from entering the actuator interior, protecting components for reduced maintenance and increased uptime

• MULTIPLE SCREW TECHNOLOGIES •

YOU CAN CHOOSE:

- Solid nuts of engineered resins offer quiet performance at the lowest cost - 5 choices
- Ball nuts offer positioning accuracy and repeatability with longer life, low-backlash available - 3 choices



NOTE: Boxed letters indicate ordering codes

OPTIONS



AUXILIARY CARRIER **D****C**

- 2X higher Fz (load) capacity
- High bending moment capacity



TUBE CLAMPS **T****C**

- Used for intermediate support
- Flush with bottom of actuator to retain low profile
- Drop-in, adjustable mounting locations (MXE16 uses T-nuts with Mounting Plates)



MOUNTING PLATES **M****P**

- To provide clearance for motor and mount
- Use in conjunction with tube clamps



SWITCHES

- Wide variety of sensing choices: Reed, Solid State PNP or NPN, all available normally open or normally closed
- Flush mount, drop-in installation
- Bright LEDs, power & signal indication
- CE rated, RoHS compliant



Sold & Serviced By:

ELECTROMATE

Toll Free Phone (877) SERV098

Toll Free Fax (877) SERV099

www.electromate.com

sales@electromate.com

B3S RODLESS SCREW DRIVE ACTUATOR

ENDURANCE TECHNOLOGYSM

Endurance Technology features are designed for maximum durability to provide extended service life.

The B3S rodless style actuator is designed for carrying moderate to heavy loads and accommodating the associated bending and dynamic moments. The B3S features a patented integral recirculating ball bearing guidance system that is protected by a stainless steel sealing band. Built-to-order in stroke lengths up to 179 inches with your choice of screw technology.

LOAD-BEARING CARRIER DESIGN

- Recirculating ball bearing system provides guidance, high efficiency and durability
- Load and moments are transmitted directly to the actuator body

FORMED END CAP WIPERS

- Prevent contaminants from entering the sealing band area to protect internal components

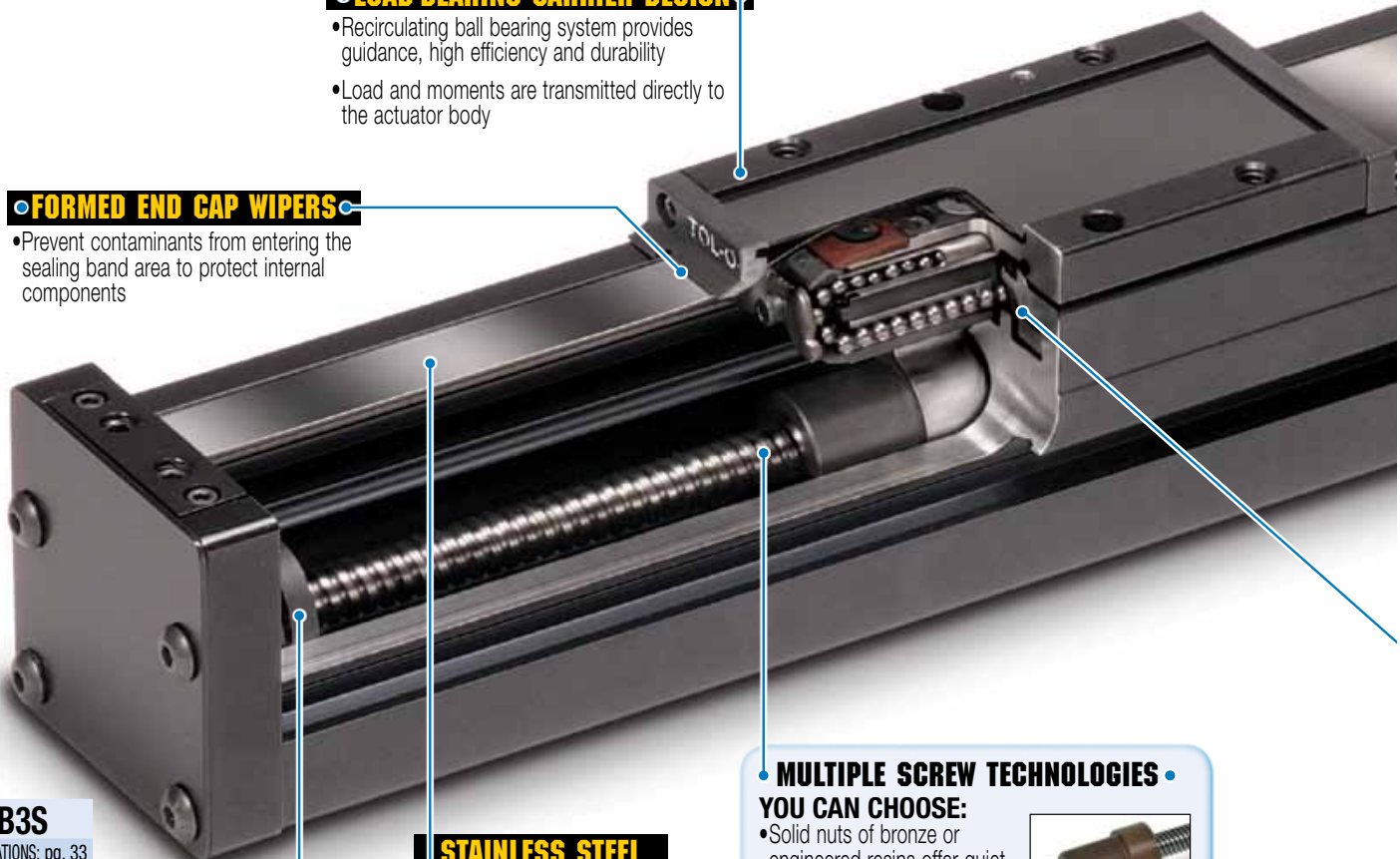

B3S

SPECIFICATIONS: pg. 33
SIZES

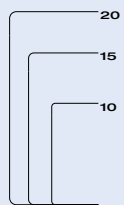

MAXIMUM
STROKE: 179"
THRUST: 2,700 lbf
SPEED: 60 in/sec
LOAD: 8,032 lb

INTERNAL BUMPERS

- Bumpers protect the screw and nut assembly from damage at end of stroke

STAINLESS STEEL SEALING BAND

- Prevents contaminants from entering the screw and nut area for extended performance
- Fatigue resistant stainless steel bands are specifically made to offer long life and will not elongate
- Provides IP44 protection for bearings and screw nut

MULTIPLE SCREW TECHNOLOGIES YOU CAN CHOOSE:

- Solid nuts of bronze or engineered resins offer quiet performance at the lowest cost; anti-backlash available
- Ball nuts offer positioning accuracy and repeatability with longer life; low-backlash available



15 DAYS
BUILT-TO-ORDER

Sold & Serviced By:

ELECTROMATE

Toll Free Phone (877) SERV098
Toll Free Fax (877) SERV099
www.electromate.com
sales@electromate.com

SCREW SUPPORT BEARINGS

- Unique high thrust bearing assembly design eliminates runout and isolates the linear forces from the drive shaft

LIGHTWEIGHT ALUMINUM DESIGN

- Black anodized extrusion design is optimized for rigidity and strength
- External switch channels on both sides allow easy placement and adjustment of position indicating switches

PATENTED WEDGE BEARING SYSTEM



- Unique design incorporates hardened steel raceways integral to the aluminum extrusion
- Bearing surfaces are adjusted at the factory for optimum preload and smooth performance



MOTOR ORIENTATION YOU CAN CHOOSE:

- Inline option directly couples the driving shafts and is a one-piece housing construction for optimum alignment and support of the motor
- Reverse-parallel option minimizes the overall length and offers a 1:1 or 2:1 belt ratio

YOUR MOTOR HERE YOU CAN CHOOSE:

- Motor or gearbox supplied and installed by Tolomatic
- Specify the device to be installed and actuator ships with proper mounting hardware
- Specify and ship your device to Tolomatic for factory installation

OPTIONS



CARRIER OPTIONS

- **AUXILIARY CARRIER** doubles the load capacity and increases pitch and yaw bending moment capacities
- **DUAL 180° CARRIER** doubles the load capacity, increases roll and yaw bending moment capacities and offers a wide mounting platform



MOUNTING OPTIONS

- **SURFACE MOUNT** two t-slots are integral on the entire underside of the actuator body for direct mounting
- **TUBE SUPPORTS** provide intermediate support of the actuator body throughout long stroke lengths



METRIC OPTION

Provides metric tapped holes for mounting of load to carrier and of actuator to mating surfaces

SWITCHES

Styles include: reed, hall-effect or triac. Select either 15ft potted cable with flying leads or 6in to quick-disconnect coupler with mating 15ft cable



Sold & Serviced By:



Toll Free Phone (877) SERV098
Toll Free Fax (877) SERV099
www.electromate.com
sales@electromate.com

TKS PRECISION SCREW DRIVE ACTUATOR

ENDURANCE TECHNOLOGYSM

Endurance Technology features are designed for maximum durability to provide extended service life.

The TKS linear table style actuator is designed for applications carrying moderate load and requiring high precision in parameters such as flatness, straightness and accuracy. The TKS actuator utilizes two parallel profiled rails with four recirculating ball linear guides to provide consistent and precise performance. Built-to-order in stroke lengths up to 96 inches with your choice of screw technology.

PRECISION MACHINED TABLE DESIGN

- A low profile design accommodates multiple mounting designs and assures a rigid and secure load



SCREW SUPPORT BEARINGS

- Unique high thrust bearing assembly design eliminates runout and isolates the linear forces from the drive shaft

MULTIPLE SCREW TECHNOLOGIES YOU CAN CHOOSE:

- Solid nuts of bronze or engineered resins offer quiet performance at the lowest cost; anti-backlash available
- Ball nuts offer positioning accuracy and repeatability with longer life; low-backlash available



TWIN LINEAR RAILS AND BEARINGS

- The industry leading bearing system is installed for consistent tracking, low friction and extended performance
- Superior straightness and flatness is verified at the factory below 0.0002 inches per inch
- Four bearing blocks provide rigid support of the carrier with the lowest possible deflection

INTERNAL SWITCHES

- End of travel and home positioning sensors are integral into the body of the actuator for clean and easy management



TKS

SPECIFICATIONS: pg. 33
SIZES

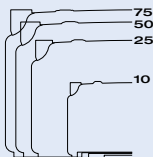

MAXIMUM

STROKE: 96"
THRUST: 3,260 lbf
SPEED: 160 in/sec
LOAD: 1,500 lb

**15 DAYS
BUILT-TO-ORDER**

Sold & Serviced By:

ELECTROMATE

Toll Free Phone (877) SERV098
Toll Free Fax (877) SERV099
www.electromate.com
sales@electromate.com

INTERNAL BUMPERS

- Bumpers protect the screw and nut assembly from damage at end of stroke

INTERNAL COUPLER

- Integral motor coupling for inline mounts provides a more compact package size

LIGHTWEIGHT ALUMINUM DESIGN

- Clear anodized extrusion design is optimized for rigidity and strength
- Mounting holes placed evenly throughout the stroke maintain rigidity



REMOVABLE COVER

- Provides rapid access to internal components and protects mechanisms from incidental damage



YOUR MOTOR HERE

YOU CAN CHOOSE:

- Motor or gearbox supplied and installed by Tolomatic
- Specify the device to be installed and actuator ships with proper mounting hardware
- Specify and ship your device to Tolomatic for factory installation

MOTOR ORIENTATION

YOU CAN CHOOSE:

- Inline option directly couples the driving shafts and is a one-piece housing construction for optimum alignment and support of the motor
- Reverse-parallel option minimizes the overall length and offers a 1:1 or 2:1 belt ratio

OPTIONS



CARRIER OPTIONS

- **AUXILIARY CARRIER** Doubles the load capacity and increases pitch and yaw bending moment capacities



SEALING OPTIONS

- **BELLOWS** provides additional protection of mechanical components in dirty environments



SWITCHES

- Styles include: reed or hall-effect. 15ft potted cable with flying leads

Sold & Serviced By:

ELECTROMATE

Toll Free Phone (877) SERV098

Toll Free Fax (877) SERV099

www.electromate.com

sales@electromate.com

MXB-U UNGUIDED BELT DRIVE ACTUATOR

ENDURANCE TECHNOLOGYSM

Endurance TechnologySM features are designed for maximum durability to provide extended service life.

The MXB-U rodless style actuator is a pre-assembled compact linear belt solution for use in applications with existing guides & supports. This economical actuator features speeds up to 200 in/sec and thrusts up to 418 lbf. Built-to-order in stroke lengths up to 200 inches.

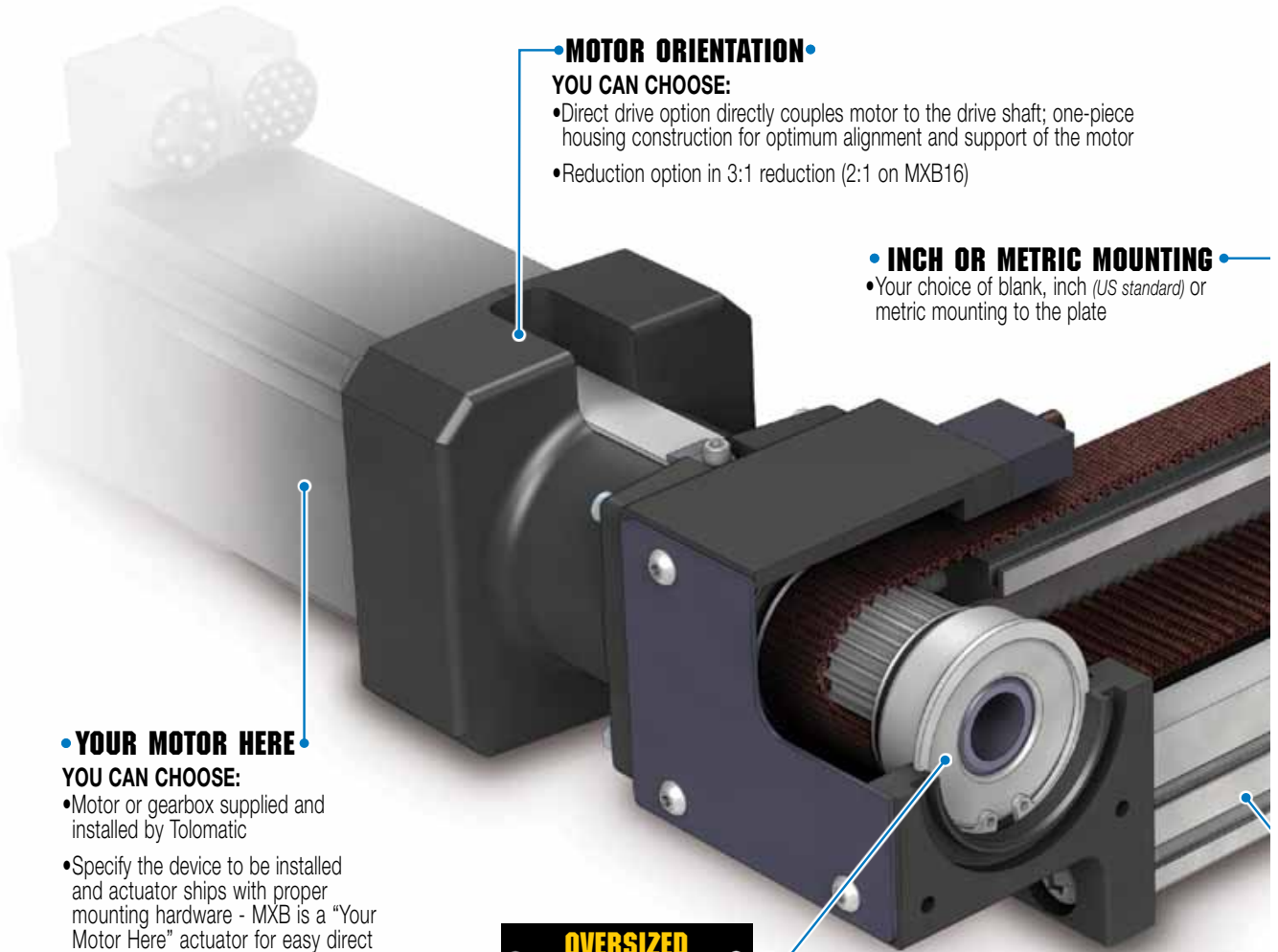

• MOTOR ORIENTATION •

YOU CAN CHOOSE:

- Direct drive option directly couples motor to the drive shaft; one-piece housing construction for optimum alignment and support of the motor
- Reduction option in 3:1 reduction (2:1 on MXB16)

• INCH OR METRIC MOUNTING •

- Your choice of blank, inch (US standard) or metric mounting to the plate

• YOUR MOTOR HERE •

YOU CAN CHOOSE:

- Motor or gearbox supplied and installed by Tolomatic
- Specify the device to be installed and actuator ships with proper mounting hardware - MXB is a "Your Motor Here" actuator for easy direct drive motor installation. Check our website (www.tolomatic.com/ymh) for complete information
- Specify and ship your device to Tolomatic for factory installation

• OVERSIZED PULLEY BEARINGS •

- Drive shaft assembly incorporates oversized shielded/sealed ball bearings for long life and high speeds

• **MXB-U**
SPECIFICATIONS: pg. 34
SIZES

MAXIMUM
STROKE: 200"
THRUST: 418 lbf
SPEED: 200 in/sec

**15 DAYS
BUILT-TO-ORDER**

Sold & Serviced By:

ELECTROMATE

Toll Free Phone (877) SERV098
Toll Free Fax (877) SERV099
www.electromate.com
sales@electromate.com

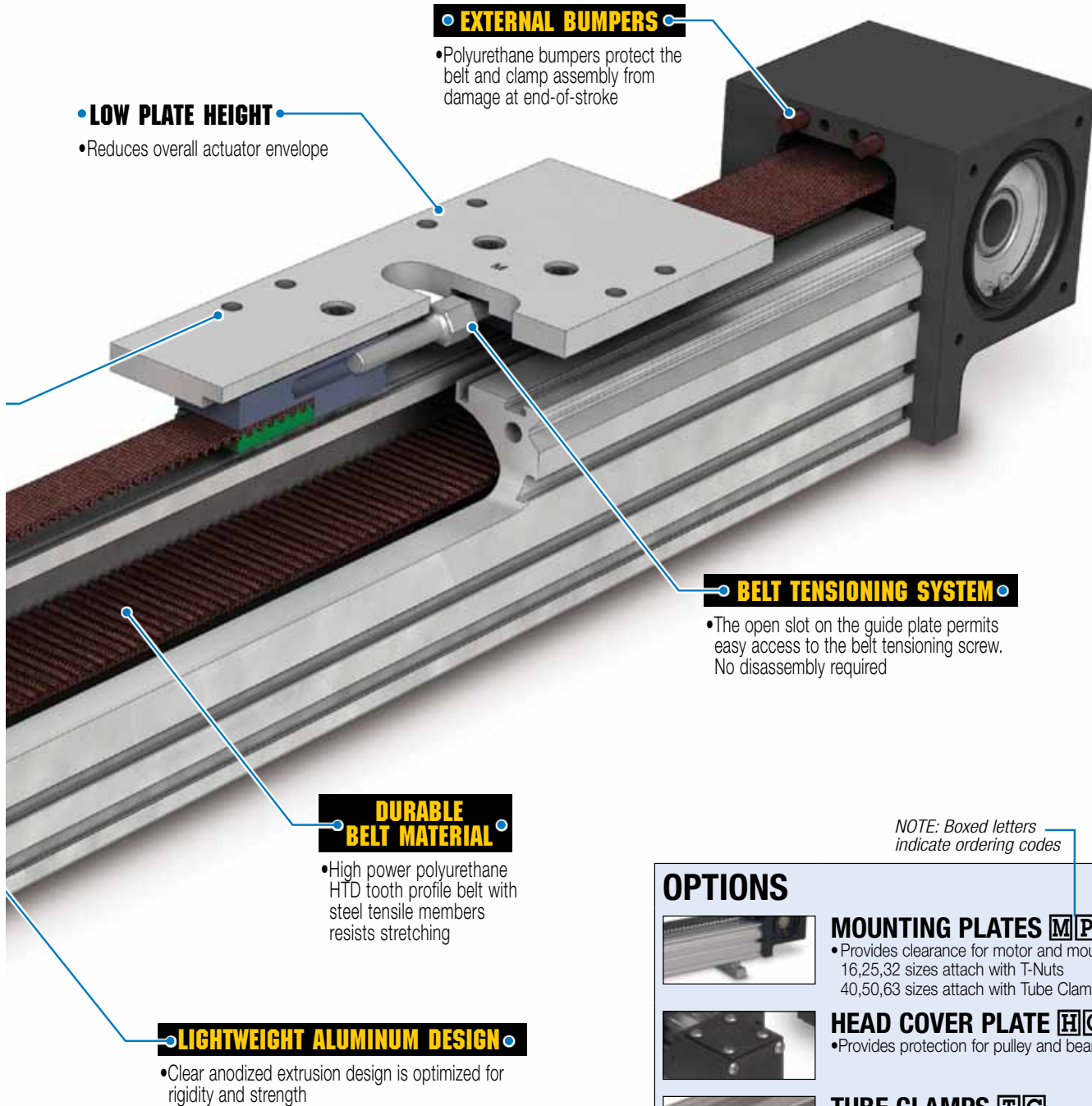

EXTERNAL BUMPERS

- Polyurethane bumpers protect the belt and clamp assembly from damage at end-of-stroke

LOW PLATE HEIGHT

- Reduces overall actuator envelope

BELT TENSIONING SYSTEM

- The open slot on the guide plate permits easy access to the belt tensioning screw. No disassembly required

DURABLE BELT MATERIAL

- High power polyurethane HTD tooth profile belt with steel tensile members resists stretching

LIGHTWEIGHT ALUMINUM DESIGN

- Clear anodized extrusion design is optimized for rigidity and strength

NOTE: Boxed letters indicate ordering codes

OPTIONS



MOUNTING PLATES MP

- Provides clearance for motor and mount
- 16,25,32 sizes attach with T-Nuts
- 40,50,63 sizes attach with Tube Clamps



HEAD COVER PLATE HCP

- Provides protection for pulley and bearing



TUBE CLAMPS TC

- Used for intermediate support
- Flush with bottom of actuator to retain low profile
- Drop-in, adjustable mounting locations (Not available on the MXB16U)

Sold & Serviced By:



Toll Free Phone (877) SERV098
 Toll Free Fax (877) SERV099
www.electromate.com
sales@electromate.com

MXB-P PROFILED RAIL BELT DRIVE ACTUATOR

ENDURANCE TECHNOLOGYSM

Endurance TechnologySM features are designed for maximum durability to provide extended service life.

The MXB-P rodless electric belt-drive actuator is designed for applications requiring moderate to heavy load carrying and guidance. The MXB-P actuator features a profiled rail system with recirculating ball linear guides for optimal performance. The MXB-P belt-driven actuator features speeds up to 150 in/sec and thrusts up to 418 lbf. Built-to-order in stroke lengths up to 200 inches.

LOW CARRIER HEIGHT

- Reduces overall actuator envelope
- Large mounting pattern for excellent load stability

DURABLE BELT MATERIAL

- High power polyurethane HTD tooth profile belt with steel tensile members resists stretching

OVERSIZED PULLEY BEARINGS

- Drive shaft assembly incorporates oversized shielded/sealed ball bearings for long life and high speeds

MOTOR ORIENTATION

YOU CAN CHOOSE:

- Direct drive option directly couples motor to the drive shaft; one-piece housing construction for optimum alignment and support of the motor
- Reduction option in 3:1 reduction (2:1 on MXB16)

YOUR MOTOR HERE

YOU CAN CHOOSE:

- Motor or gearbox supplied and installed by Tolomatic
- Specify the device to be installed and actuator ships with proper mounting hardware - MXB is a "Your Motor Here" actuator for easy direct drive motor installation. Check our website (www.tolomatic.com/ymh) for complete information
- Specify and ship your device to Tolomatic for factory installation

15 DAYS BUILT-TO-ORDER

INCH OR METRIC MOUNTING

- Your choice of inch (US standard) or metric mounting to the carrier

MXB-P

SPECIFICATIONS: pg. 34

SIZES

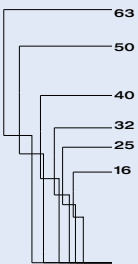

MAXIMUM
STROKE: 200"
THRUST: 418 lbf
SPEED: 150 in/sec
LOAD: 2,583 lb

COMPLETE INFORMATION:
www.tolomatic.com

Sold & Serviced By:

ELECTROMATE

Toll Free Phone (877) SERV098
Toll Free Fax (877) SERV099
www.electromate.com
sales@electromate.com

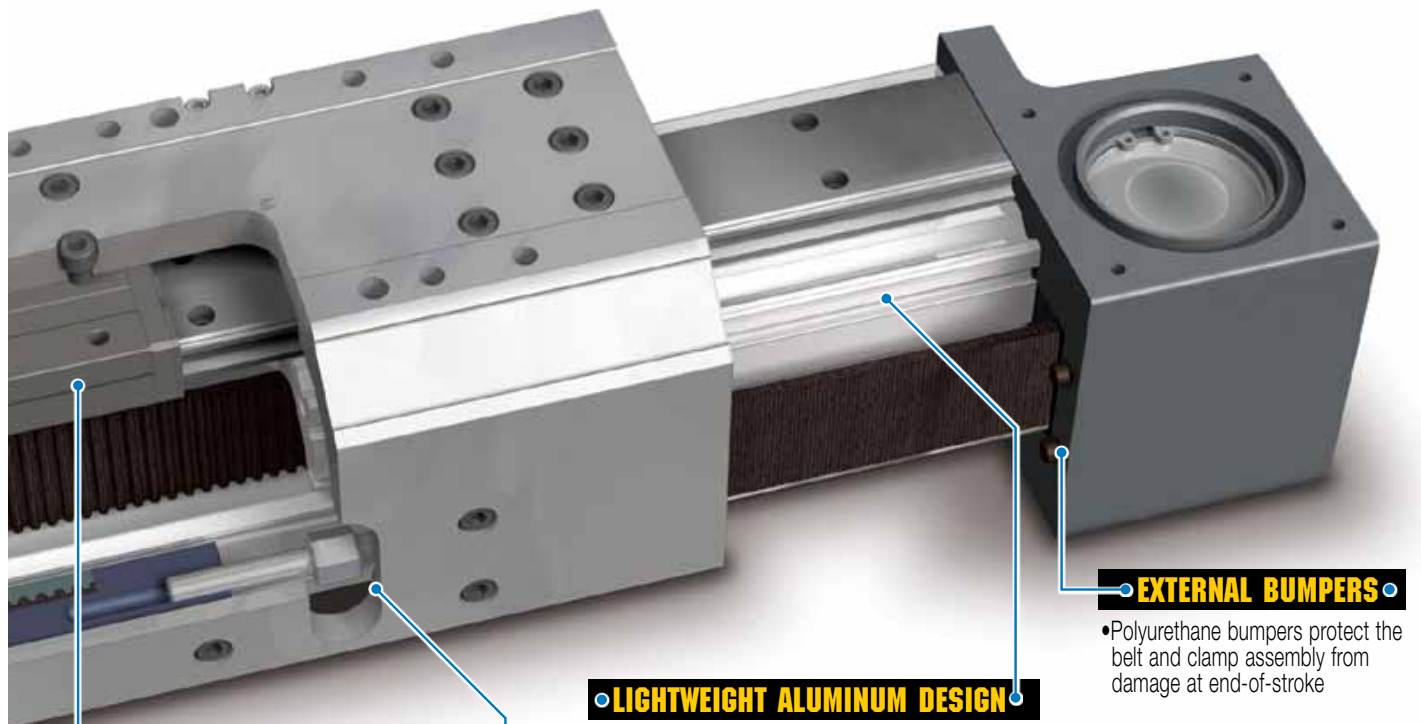

BELT TENSIONING SYSTEM

- The open slot on the carrier side permits easy access to the belt tensioning screw. No disassembly required and no need to remove the load from the carrier

LIGHTWEIGHT ALUMINUM DESIGN

- Clear anodized extrusion design is optimized for rigidity and strength

EXTERNAL BUMPERS

- Polyurethane bumpers protect the belt and clamp assembly from damage at end-of-stroke

RECIRCULATING BALL BEARINGS

- Recirculating ball bearings are used to reduce friction and extend actuator life
- Designed with a grease pocket between ball elements to reduce friction, noise and maintenance
- Large permissible moment loads
- High speed operation, low heat generation
- High precision, smooth, low friction motion



NOTE: Boxed letters indicate ordering codes

OPTIONS



AUXILIARY CARRIER DC

- 2X higher Fz & Fy (load) capacity
- High bending moment capacity



MOUNTING PLATES MP

- Provides clearance for motor and mount
- 16,25,32 sizes attach with T-Nuts
- 40,50,63 sizes attach with Tube Clamps



TUBE CLAMPS TC

- Used for intermediate support
- Flush with bottom of actuator to retain low profile
- Drop-in adjustable mounting locations
- (Not available on the 16, 25 or 32 MXB-P sizes)



HEAD COVER PLATE HCP

- Provides protection for pulley and bearing

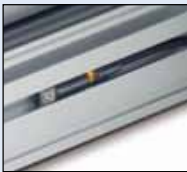

SWITCHES

- Wide variety of sensing choices: Reed, Solid State PNP or NPN, available normally open or normally closed
- Flush mount, drop-in installation
- Bright LEDs, power & signal indication
- CE rated, RoHS compliant

B3W RODLESS BELT DRIVE ACTUATOR

ENDURANCE TECHNOLOGYSM

Endurance Technology features are designed for maximum durability to provide extended service life.

The B3W rodless style actuator is designed for carrying moderate to heavy loads at moderate to high speeds with large bending moment capacity. Based upon our BC3 pneumatic band cylinder, it utilizes a patented integral recirculating ball bearing guidance system that provides consistent and durable performance. The B3W belt-driven actuator features speeds up to 200 in/sec. and thrusts up to 325 lbf. Built-to-order in stroke lengths up to 292 inches.

• YOUR MOTOR HERE

YOU CAN CHOOSE:

- Motor or gearbox supplied and installed by Tolomatic
- Specify the device to be installed and actuator ships with proper mounting hardware
- Specify and ship your device to Tolomatic for factory installation

• MOTOR ORIENTATION

YOU CAN CHOOSE:

- Direct drive option directly couples the driving shafts and is a one-piece housing construction for optimum alignment and support of the motor
- Reduction drive option offers the ability to reduce the reflected inertia and lower the motor torque requirements

• LIGHTWEIGHT ALUMINUM DESIGN

- Black anodized extrusion design is optimized for rigidity and strength
- External switch channels on both sides allow easy placement and adjustment of position indicating switches

• OVERSIZED PULLEY BEARINGS

- Drive shaft assembly incorporates sealed ball bearings for complete support of the increased belt tension at high speeds

• MULTIPLE BELT TECHNOLOGIES

YOU CAN CHOOSE:

- Polyurethane steel-cord reinforced HTD style belt (standard)
- Polyurethane Kevlar reinforced HTD style belt

• INTERNAL BUMPERS

- Bumpers protect the belt and clamp assembly from damage at end of stroke

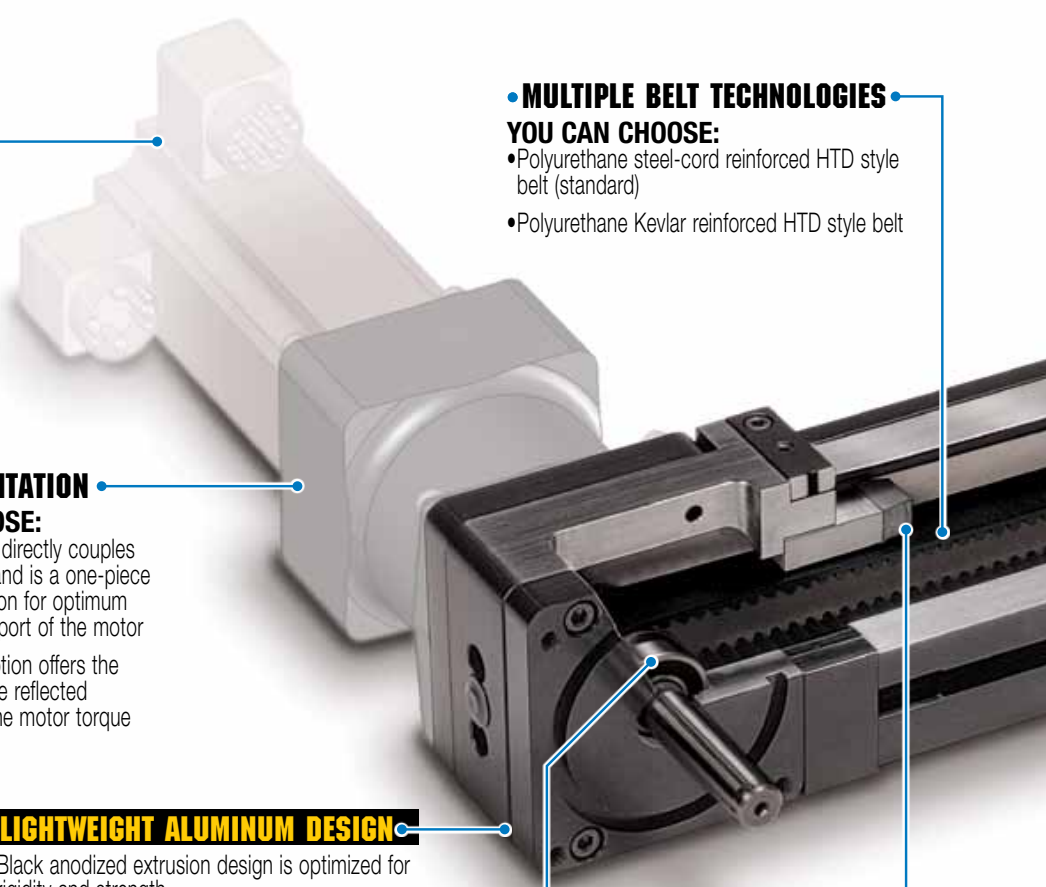

• B3W

SPECIFICATIONS: pg. 34
SIZES

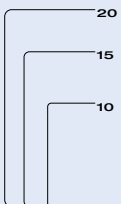

MAXIMUM
STROKE: 292"
THRUST: 325 lbf
SPEED: 200 in/sec
LOAD: 8,032 lb

Sold & Serviced By:

ELECTROMATE

Toll Free Phone (877) SERV098
Toll Free Fax (877) SERV099
www.electromate.com
sales@electromate.com

PATENTED WEDGE BEARING SYSTEM



- Unique design incorporates hardened steel raceways integral to the aluminum extrusion
- Bearing surfaces are adjusted at the factory for optimum preload and smooth performance



FORMED END-CAP WIPERS

- Prevent contaminants from entering the sealing band area to protect internal components

BELT TENSIONING SYSTEM

- Full access to the idle pulley allows ease of adjustment for alignment and tensioning
- Dual adjustment screws and field tensioning kit provide simple maintenance

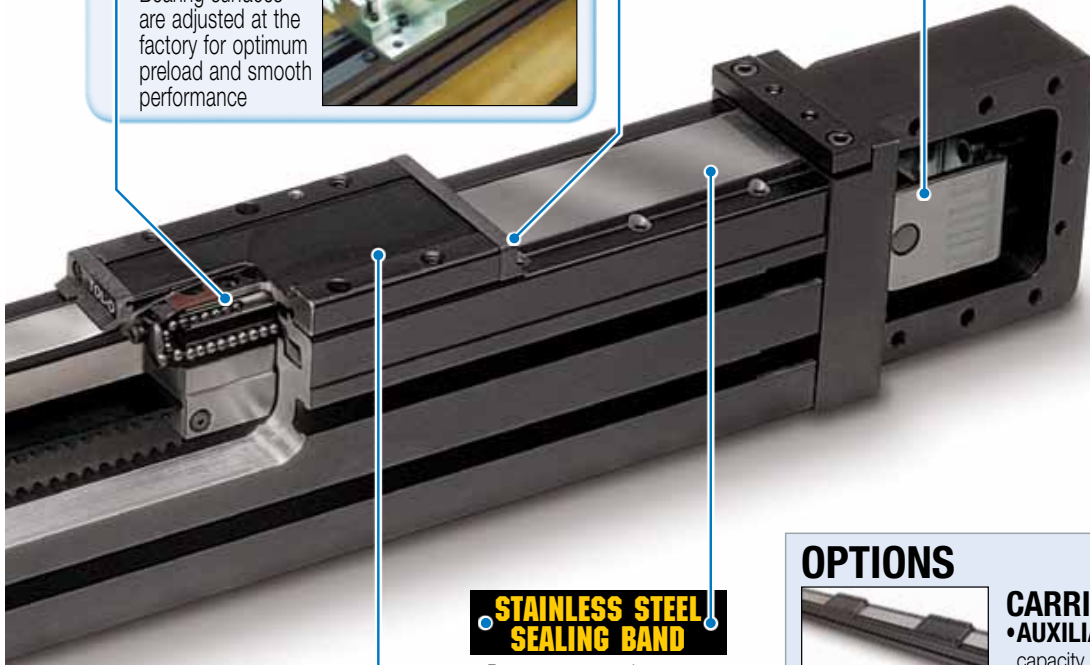

LOAD-BEARING CARRIER DESIGN

- Recirculating ball bearing system provides guidance, high efficiency and long life
- Load and moments are transmitted directly to the actuator body

STAINLESS STEEL SEALING BAND

- Prevents contaminants from entering the belt and pulley area for extended performance
- Fatigue resistant stainless steel bands are specifically made to offer long life and will not elongate
- Provides IP44 protection for bearings and interior components

OPTIONS



CARRIER OPTIONS

- **AUXILIARY CARRIER** doubles the load capacity and increases pitch and yaw bending moment capacities
- **DUAL 180° CARRIER** doubles the load capacity, increases roll and yaw bending moment capacities and offers a wide mounting platform



MOUNTING OPTIONS

- **SURFACE MOUNT** two t-slots are integral on the entire underside of the actuator body for direct mounting
- **TUBE SUPPORTS** provide intermediate support of the actuator body throughout long stroke lengths



METRIC OPTION

Provides metric tapped holes for mounting of load to carrier and of actuator to mating surfaces

SWITCHES

Styles include: reed, hall-effect or triac



Sold & Serviced By:

ELECTROMATE

Toll Free Phone (877) SERV098
 Toll Free Fax (877) SERV099
www.electromate.com
sales@electromate.com

TKB PRECISION BELT DRIVE ACTUATOR

ENDURANCE TECHNOLOGYSM

Endurance Technology features are designed for maximum durability to provide extended service life.

The TKB linear table style actuator is designed for high speed applications requiring high precision in parameters such as flatness and straightness. This unique actuator utilizes two parallel profiled rails with four recirculating ball linear guides to provide wide and stable mounting surface with consistent and precise performance. The TKB belt-driven actuator features speeds up to 100 in/sec. and thrusts up to 245 lbf. Built-to-order in stroke lengths up to 96 inches.

REMOVABLE COVER

- Provides rapid access to internal components and protects mechanisms from incidental damage



INTERNAL SWITCHES

- End of travel and home positioning sensors are integral into the body of the actuator for clean and easy management



MULTIPLE BELT TECHNOLOGIES YOU CAN CHOOSE:

- Polyurethane steel-cord reinforced HTD style belt (standard)
- Polyurethane Kevlar reinforced HTD style belt

PRECISION MACHINED TABLE DESIGN

- A wide and low profile design accommodates multiple mounting designs and assures a rigid and secure load



TKB

SPECIFICATIONS: pg. 35
SIZES

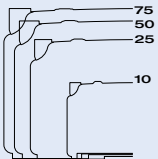

MAXIMUM

STROKE: 96"
THRUST: 245 lbf
SPEED: 100 in/sec
LOAD: 1,500 lb

Sold & Serviced By:

ELECTROMATE

Toll Free Phone (877) SERV098
Toll Free Fax (877) SERV099
www.electromate.com
sales@electromate.com



YOUR MOTOR HERE

YOU CAN CHOOSE:

- Motor or gearbox supplied and installed by Tolomatic
- Specify the device to be installed and actuator ships with proper mounting hardware
- Specify and ship your device to Tolomatic for factory installation

MOTOR ORIENTATION

YOU CAN CHOOSE:

- Direct drive option directly couples the driving shafts and is a one-piece housing construction for optimum alignment and support of the motor
- Reduction drive option offers the ability to reduce the reflected inertia and lower the motor torque requirements

EXTERNAL BUMPERS

- External bumpers, both ends, are standard
- Protect actuator and load from damage

LIGHTWEIGHT ALUMINUM DESIGN

- Clear anodized extrusion design is optimized for rigidity and strength
- Mounting holes placed evenly throughout the stroke maintain rigidity



TWIN LINEAR RAILS AND BEARINGS

- The industry leading bearing system is installed for consistent tracking, low friction and extended performance
- Superior straightness and flatness is verified at the factory below 0.0002 inches per inch
- Four bearing blocks provide rigid support of the carrier with the lowest possible deflection

OPTIONS



CARRIER OPTIONS

- **AUXILIARY CARRIER** Doubles the load capacity and increases pitch and yaw bending moment capacities



SEALING OPTIONS

- **BELLOWS** provides additional protection of mechanical components in dirty environments



SWITCHES

- Styles include: reed or hall-effect. 15ft potted cable with flying leads



Sold & Serviced By:

ELECTROMATE

Toll Free Phone (877) SERV098

Toll Free Fax (877) SERV099

www.electromate.com

sales@electromate.com

ERD – ELECTRIC ROD-STYLE ACTUATOR

• ENDURANCE TECHNOLOGYSM •

Endurance Technology features are designed for maximum durability to provide extended service life.

The ERD is an economical rod-style electric actuator designed as an alternate to pneumatic cylinders and an option for automating manual processes. The ERD is compatible with many NEMA & metric mount stepper and servo motors to create a flexible, powerful electric actuator solution. Built-to-order in stroke lengths up to 24 inches.



• PATENT PENDING •

• MULTIPLE SCREW TECHNOLOGIES •

YOU CAN CHOOSE:

• Solid nuts of engineered resins offer quiet performance at the lowest cost



• Ball nuts offer positioning accuracy and repeatability with longer life



• THREADED NOSE MOUNT WITH JAM NUT

- Metric threads
- Convenient mounting for many applications



• MALE THREADED ROD END

- Standard metric threads
- Compatible with many commercially available metric rod end accessories

• NOSE BEARING

- Engineered resins for smooth operation
- Provides critical support of thrust rod

• STAINLESS-STEEL THRUST TUBE

- 300 series stainless-steel thrust tube provides high rigidity and corrosion resistance

• INTEGRAL GUIDE RODS AND BEARINGS

- Stainless-steel guide rods provide high rigidity and low deflection
- Four composite bearings support the load for smooth consistent motion

• ERD

SPECIFICATIONS: pg. 35
SIZES



MAXIMUM

STROKE: 24"
THRUST: 500 lbf
SPEED: 40 in/sec

Sold & Serviced By:



Toll Free Phone (877) SERV098
Toll Free Fax (877) SERV099
www.electromate.com
sales@electromate.com

300 SERIES STAINLESS-STEEL MAIN TUBE

- 300 Series stainless-steel main tube provides high rigidity and corrosion resistance

INTERNAL MAGNET

- This standard feature accommodates reed and solid state switches anywhere on the main tube

GUIDE (GD2 OPTION)

- Load guidance, tooling plate and anti-rotate

NEMA MOTOR MOUNT

- ERD06: NEMA11 • ERD10: NEMA17
- ERD15: NEMA23

YOUR MOTOR HERE

- ERD15 & 20: Over 500 motor mounts available with 5 day delivery.
 - ERD15: NEMA23 or 60mm metric
 - ERD20: NEMA23 or 60mm metric & NEMA34 or 80mm metric

METRIC MOTOR MOUNT (OPTION)

- ERD10: 40mm Frame
- Made of aluminum
- ⊗ Not available for 06, 15 & 20 sizes

OVERSIZED MAIN BEARING

- Oversized for long life
- Accommodates high thrust load

OPTIONS



TRR – TRUNNION MOUNT

For applications that require pivoting, 300 series stainless steel construction



FM2 – FOOT MOUNT*

For applications that require bottom mounting, 300 series stainless steel construction



FFG – FRONT FLANGE MOUNT*

For front mounting applications, 300 series stainless steel construction



SWITCHES*

Choose from: Reed, Solid State PNP or NPN, all available in normally open

IP67 – IP67

An IP67 upgrade (static rating) for protection against water and dust ingress (see page ERD_6)

SS1 – STAINLESS STEEL

Same ERD actuator made of all 300 series stainless steel for corrosion resistance. Available on all sizes.

SS2 – STAINLESS STEEL

SS1 option plus IP67 and protective motor enclosure (see page ERD_6) ⊗ Not available for ERD06 & ERD20

GD2 – GUIDE

For applications that require anti-rotation, or guidance and load bearing. Made of lightweight aluminum

***NOTE:** Foot Mount, Front Flange Mount and Switches are shipped together with the actuator but are not installed by Tolomatic.

Sold & Serviced By:

ELECTROMATE

Toll Free Phone (877) SERV098

Toll Free Fax (877) SERV099

www.electromate.com

sales@electromate.com

SmartActuator ICR PLUS

INTEGRATED CONTROL ROD-STYLE ACTUATOR

ENDURANCE TECHNOLOGYSM

Endurance Technology features are designed for maximum durability to provide extended service life. This endurance technology symbol indicates our durability design features.

The SmartActuator is a controller, drive and motor integrated into one compact, durable, lightweight actuator. Designed for simple extend and retract operation the ICR Basic can easily be installed and set up by anyone familiar with pneumatic or hydraulic cylinders. For flexibility, the Plus offers indexer programming and network communication capabilities for a wide variety of demanding applications. Built-to-order in stroke lengths up to 24 inches.

**15 DAYS
BUILT-TO-ORDER**

ICR PLUS - EXCLUSIVE OPTION

COMMUNICATION PORTS



- DeviceNet – daisy chain up to 63 actuators
- Two ports for easy daisy chain wiring
- Optional CANopen – daisy chain up to 127 actuators (CANopen device profile DSP-402)

MOTOR ORIENTATION

YOU CAN CHOOSE

- **LM1** In-line option directly couples the driving shaft and is a one-piece housing construction for optimum alignment and support of the motor
- **RP** Reverse-parallel option minimizes the overall length and offers 1:1 or 2:1 belt ratio

BALL SCREW TECHNOLOGY

- Oversized ball screw selection for extremely long service life
- Lubricated for life of actuator at the factory with the highest quality synthetic grease



THRUST TUBE

- Hardened nickel plated steel rod ground and polished for greater durability than stainless steel
- Excellent corrosion resistance from many chemicals and resists incidental contact damage

INTERNAL BUMPER

- Bumper protects the screw and nut assembly from damage at the end of stroke

THREADED ROD END

- Nickel plated aluminum for corrosion resistance
- Provides a common interface to multiple rod end options

ANTI-ROTATE BEARING

- Engineered resin guide bearings provide anti-rotation of the thrust rod
- Support the thrust tube and nut assembly through entire stroke length

BEARING

- Unique nose bearing material allow smooth operation and support of the thrust rod

ROD WIPER

- Prevents contaminants from entering the housing for extended life of the actuator

ICR

SPECIFICATIONS: pg. 35
SIZES



MAXIMUM

STROKE: 24"

THRUST: 720 lbf

SPEED: 25 in/sec

Sold & Serviced By:

ELECTROMATE

Toll Free Phone (877) SERV098

Toll Free Fax (877) SERV099

www.electromate.com

sales@electromate.com

ICR PLUS - EXCLUSIVE FEATURE

DIGITAL DRIVE

- Advanced indexer programming environment for maximum flexibility to solve the most demanding applications
- CANopen and DeviceNet communications allow daisy chain of up to 127 units. RS-232 port included
- Full suite of software for setup, diagnostics & debug

DIGITAL ENCODER

- For closed loop control

CONNECTORS

- Standard
- Optional IP65



ALUMINUM MOTOR ENCLOSURE

- Fins provide thermal heat dissipation for higher performance

SERVO MOTOR

- 100% duty cycle for demanding applications
- Internal thermal protection

HIGH THRUST BEARING

- Oversized bearing supports the leadscrew and motor
- Large shaft and bearings for longer life and tolerance of radial and axial loads

LIGHTWEIGHT ALUMINUM DESIGN

- Clear anodized extrusion design is optimized for rigidity and strength
- External switch channels and mounting channels along full length on both sides allow easy placement of position indicating switches and tube clamps/mounting plates

FLEXIBLE MOUNTING

- Front face and bottom mounting holes are standard
- Options: front flange, plates, tube clamps, trunnions, rear clevis (RP models only)

OPTIONS

MOUNTING



- Plate (MIP or EM2)
- Tube Clamps
- Front Flange
- Trunnion
- Clevis

ROD END



- External Threads
- Clevis
- Eye
- Alignment Coupler

BRAKE



For vertical applications and energy savings when ICR is not in use

IP65



For protection against water and dust ingress

COMM. PORTS

For DeviceNet & CANopen, see above

CABLES



- Signal Cable (5m, IP40 or IP65)
- Power Cable (5m, IP40 or IP65)
- Communication cable (1m or 5m)

STARTER KIT

USB to CANopen converter and comm. cables

SWITCHES



Styles include: Reed, Solid State PNP or NPN, all available in normally open or normally closed. RoHs compliant, CE rated

Sold & Serviced By:

ELECTROMATE

Toll Free Phone (877) SERV098

Toll Free Fax (877) SERV099

www.electromate.com

sales@electromate.com

RSA ROD-STYLE ACTUATOR

ENDURANCE TECHNOLOGYSM

Endurance Technology features are designed for maximum durability to provide extended service life.

The RSA rod screw actuator is ideal for medium to high thrust applications of guided loads. The compact design and cylinder style operation make this solution ideal for applications that were historically solved with pneumatic or hydraulic power. Many mounting options are available allowing the actuator to be installed in numerous applications. Built-to-order in stroke lengths up to 60 inches with your choice of screw technology.

**15 DAYS
BUILT-TO-ORDER**

MULTIPLE SCREW TECHNOLOGIES

YOU CAN CHOOSE:

- Solid nuts of bronze or engineered resins offer quiet performance at the lowest cost; anti-backlash available
- Ball nuts offer efficiency at a cost effective price; low-backlash available
- Roller nuts provide the highest thrust and life ratings available



SCREW SUPPORT BEARING

- Engineered resin bearing provides continuous support of screw

THRUST TUBE

- Steel thrust tube supports extremely high force capabilities
- Salt bath nitride treatment provides excellent corrosion resistance, surface hardness and is very resistant to adherence of potential contaminants

INTERNAL BUMPERS

- Bumpers protect the screw and nut assembly from damage at both ends of stroke

THREADED ROD END

- Provides a common interface to multiple rod end options

RSA

SPECIFICATIONS: pg. 35
SIZES



MAXIMUM

STROKE: 60"
THRUST: 7,350 lbf
SPEED: 123 in/sec

OPTIONAL GREASE ZERK

- Provided with roller nut/screw this relubrication system provides extended screw service life
- Convenient lubrication without disassembly



ROD WIPER

- Prevents contaminants from entering the housing for extended life of the actuator

NOSE BEARING

- Support the thrust tube and nut assembly through entire stroke length
- Unique nose bearing material allows for smooth operation and support of the thrust rod

Sold & Serviced By:

ELECTROMATE

Toll Free Phone (877) SERV098
Toll Free Fax (877) SERV099
www.electromate.com
sales@electromate.com

YOUR MOTOR HERE

YOU CAN CHOOSE:

- Specify the device to be installed and actuator ships with proper mounting hardware
- Specify and ship your device to Tolomatic for factory installation
- Motor or gearbox supplied and installed by Tolomatic

MOTOR ORIENTATION

YOU CAN CHOOSE:

- Inline option directly couples the driving shaft and is typically a one-piece housing construction for optimum alignment and support of the motor
- Reverse-parallel option minimizes the overall length and offers a belt reduction drive with a 1:1 or 2:1 ratio

HIGH THRUST BEARING

- Unique high thrust bearing assembly design eliminates runout and isolates the linear forces for the drive shaft

INTERNAL NUT BEARINGS

- Engineered resin guide bearings provide anti-rotation of the thrust rod
- Support the thrust tube and nut assembly through entire stroke length

LIGHTWEIGHT ALUMINUM DESIGN

- Black anodized extrusion design is optimized for rigidity and strength
- External switch channels on all sides allow easy placement of position indicating switches

INGRESS PROTECTION

- Gasket Kits available upon request for ingress protection against splashing water and dust

OPTIONS

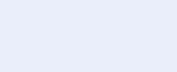
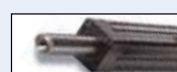
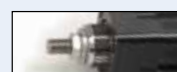
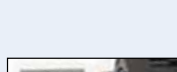

MOUNTING

- Plate
- Foot
- Front Flange
- Rear Flange
- Clevis
- Eye
- Trunnion

ROD END

- External Threads
- Clevis
- Eye
- Alignment Coupler
- Rod Extension

METRIC OPTION

Provides metric tapped holes for mounting of load to rod end and of actuator to mating surfaces

SWITCHES

Choose from: Reed, Solid State PNP or NPN, all available normally open or normally closed

Sold & Serviced By:



Toll Free Phone (877) SERV098
Toll Free Fax (877) SERV099
www.electromate.com
sales@electromate.com

GSA GUIDED ROD-STYLE ACTUATOR

ENDURANCE TECHNOLOGYSM

Endurance Technology features are designed for maximum durability to provide extended service life.

The GSA guided screw actuator is ideal for medium to high thrust applications. The self-contained guided rod design and cylinder slide style operation make this solution ideal for applications requiring guidance and support of the load. A robust, wide tooling plate allows easy mounting of the required end effectors for many applications. Built-to-order in stroke lengths up to 36 inches with your choice of screw technology.

MULTIPLE SCREW TECHNOLOGIES

YOU CAN CHOOSE:

- Solid nuts of bronze or engineered resins offer quiet performance at the lowest cost; anti-backlash available
- Ball nuts offer efficiency at a cost effective price; low-backlash available
- Roller nuts (available on request) provide the highest thrust and life ratings available



LIGHTWEIGHT ALUMINUM DESIGN

- Black anodized bearing block provides solid structural support and multiple mounting options
- Black anodized tube extrusion design is optimized for rigidity and strength
- External switch channels on all sides allow easy placement of position indicating switches

ROD WIPER

- Prevents contaminants from entering the housing for extended life of the actuator

ANODIZED ALUMINUM THRUST TUBE

- Lightweight design directly provides thrust with minimal additional inertia
- Corrosion resistant plating provides excellent protection from many chemicals

INTEGRAL GUIDE RODS AND BEARINGS

- Hardened steel guide rods provide high rigidity and low deflection
- Four composite or linear ball bearings support the load for smooth, consistent motion
- Lubrication wick supplies lube for life of actuator
- Oversized rods available for higher load capacity
- Stainless steel shafting option available for corrosion resistance

GSA

SPECIFICATIONS: pg. 35
SIZES



MAXIMUM

STROKE: 36"
THRUST: 2,700 lbf
SPEED: 123 in/sec
LOAD: 1,200 lb

**15 DAYS
BUILT-TO-ORDER**

Sold & Serviced By:

ELECTROMATE

Toll Free Phone (877) SERV098
Toll Free Fax (877) SERV099
www.electromate.com
sales@electromate.com

**• YOUR MOTOR HERE •
YOU CAN CHOOSE:**

- Specify the device to be installed and actuator ships with proper mounting hardware
- Specify and ship your device to Tolomatic for factory installation
- Motor or gearbox supplied and installed by Tolomatic

**• MOTOR ORIENTATION •
YOU CAN CHOOSE:**

- Inline option directly couples the driving shafts and is typically a one-piece housing construction for optimum alignment and support of the motor
- Reverse-parallel option minimizes the overall length and offers a 1:1 or 2:1 belt ratio

• SCREW SUPPORT BEARINGS •

- Unique high thrust bearing assembly design eliminates runout and isolates the linear forces for the drive shaft
- Engineered resin bearing provides continuous support of screw

• PRECISION MACHINED SURFACES •

- Extruded bearing housing is precision machined on two surfaces for true and easily aligned linear motion
- Tooling plate is aligned and assembled to provide a precise mounting surface

• INGRESS PROTECTION •

- Gasket Kits available upon request for ingress protection against splashing water and dust

OPTIONS

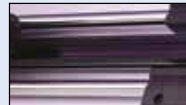

• OVERSIZED GUIDE RODS

Available for increased load capacity or decreased deflection



• STOP COLLARS

Provide a positive stop mechanism when required



• CORROSION RESISTANCE

Includes 316 stainless steel guide rods and fasteners for better environmental protection



• METRIC OPTION

Provides metric tapped holes for mounting of load to tooling plate and of actuator to mating surfaces

• SWITCHES

Choose from: Reed, Solid State PNP or NPN, all available normally open or normally closed

Sold & Serviced By:



Toll Free Phone (877) SERV098
Toll Free Fax (877) SERV099
www.electromate.com
sales@electromate.com

IMA INTEGRATED MOTOR ACTUATOR

ENDURANCE TECHNOLOGYSM

Endurance Technology features are designed for maximum durability to provide extended service life.

The IMA is a compact, durable, high force rod-style actuator. The IMA integrates a servo motor into a ball or roller screw-driven actuator to provide efficient high force in a compact lightweight design envelope. Our patent-pending design allows for easy re-lubrication without disassembly for extremely long service life. Built-to-order in stroke lengths up to 18 inches with your choice of screw technology.

MULTIPLE SCREW TECHNOLOGIES YOU CAN CHOOSE:

- Ball nuts offer efficiency at a cost effective price
- Roller nuts provide the highest thrust and life ratings available



HIGH POSITIONAL ACCURACY

SCREW ACCURACY

Roller Nut	± 0.0004"/ft.	± 0.0102mm/300mm
Ball Nut	± 0.002"/ft.	± 0.051mm/300mm

INTERNAL BUMPERS

- Bumpers protect the screw and nut assembly from damage at end of stroke

REPLACEABLE BEARING CARTRIDGE

- Doubles as a locating pilot for positioning actuator

ROD WIPER

- Prevents contaminants from entering the actuator for extended life

GREASE PORT

- Patent pending screw relubrication system provides extended screw service life
- Convenient lubrication without disassembly

INTEGRAL MOUNTING

- Four metric threaded holes on front face are available for direct mounting or addition of customized options

THREADED ROD END

- Zinc plated alloy steel construction for corrosion resistance
- Provides a common interface to multiple rod end options

THRUST TUBE

- Steel thrust tube supports extremely high force capabilities
- Salt bath nitride treatment provides excellent corrosion resistance, surface hardness and is very resistant to adherence of weld slag, water and other potential contaminants

LIGHTWEIGHT ALUMINUM DESIGN

- Black anodized extrusion design is optimized for rigidity and strength

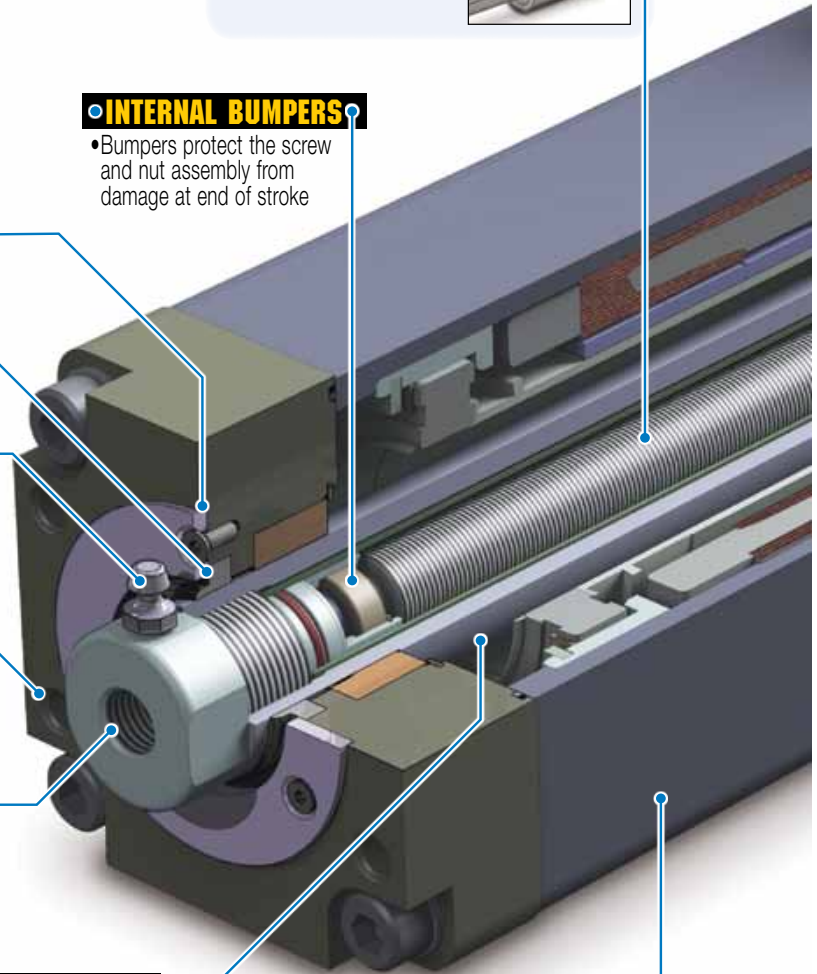

IMA

SPECIFICATIONS: pg. 35
SIZES

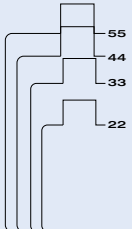

MAXIMUM

STROKE: 18"
THRUST: 6,875 lbf
SPEED: 52.5 in/sec

Sold & Serviced By:

ELECTROMATE

Toll Free Phone (877) SERV098
Toll Free Fax (877) SERV099
www.electromate.com
sales@electromate.com

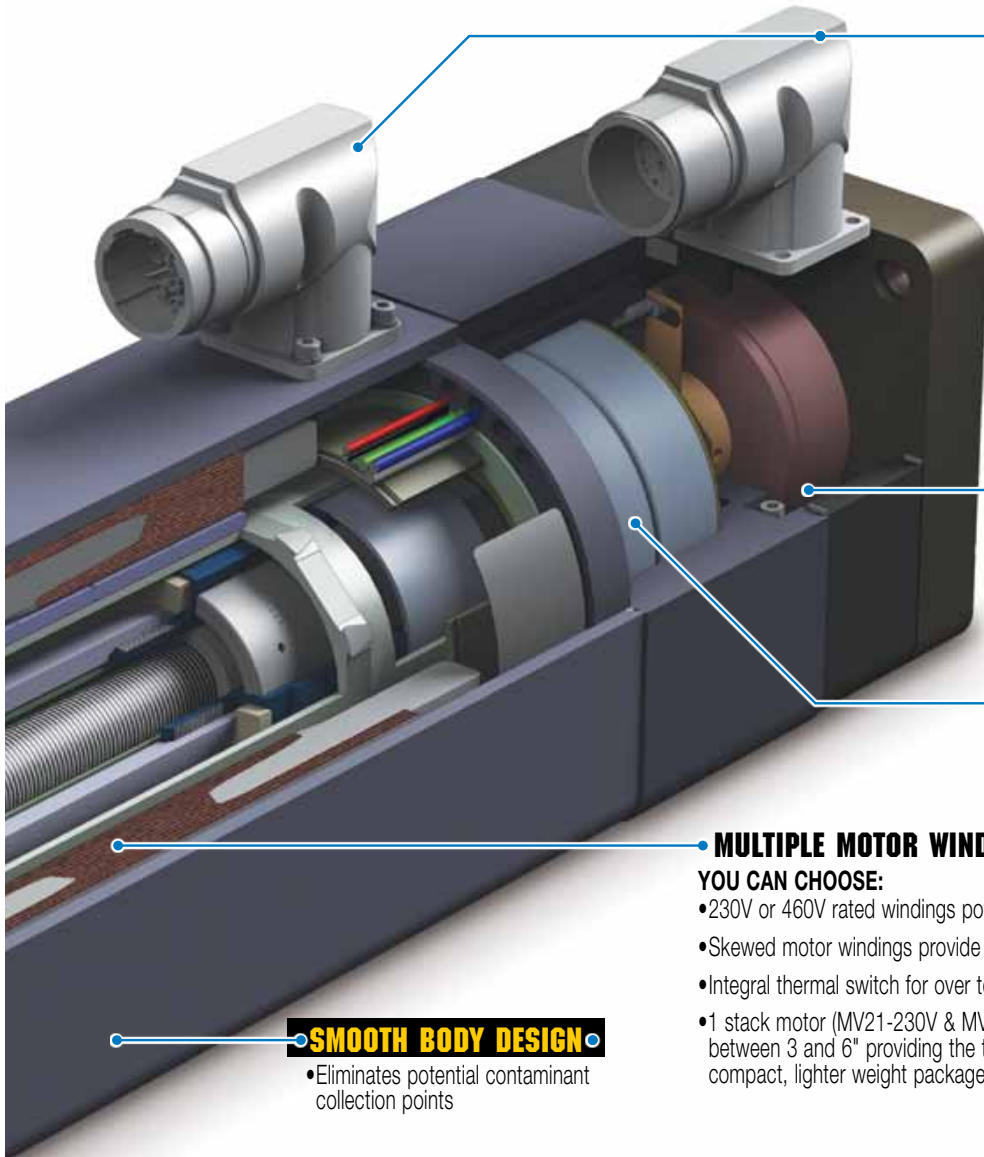

CONNECTORS

YOU CAN CHOOSE FROM:

- Connector choice and wiring emulates popular motor manufacturers for compatibility:
 - Tolomatic Standard
 - Bosch Rexroth MSK Series
 - Emerson FM & NT Series
 - Lenze MCA Series
 - more to come...

- STAGGERED CONNECTORS for convenient installation

- 270° Rotatable & Box mount options available

HIGH RESOLUTION FEEDBACK

YOU CAN CHOOSE:

- Digital encoder
- Multi-turn absolute encoder
- Resolver

HIGH THRUST BEARING

- Provides complete support of screw and protects the feedback device from linear forces

MULTIPLE MOTOR WINDINGS

YOU CAN CHOOSE:

- 230V or 460V rated windings potted directly into actuator housing
- Skewed motor windings provide minimal torque ripple for smooth linear motion
- Integral thermal switch for over temperature protection
- 1 stack motor (MV21-230V & MV41-460V) available for the IMA33, allows strokes between 3 and 6" providing the thrust needed for many applications in a more compact, lighter weight package

SMOOTH BODY DESIGN

- Eliminates potential contaminant collection points



Modifications:

- Contact Tolomatic for white epoxy, stainless steel, food grade or mil-spec versions of the IMA

OPTIONS

MOUNTING

- Front Face - Standard
- Side Mounting Holes, 2 sides & bottom (no photo)
- Mounting Plates
- Rear Clevis
- Front Flange
- Trunnion, Rear or Front

ROD END

- Internal Thread - Standard
- External Threads
- Clevis
- Spherical Eye
- Alignment Coupler

BRAKE

- 24V Spring held / electronically released

IP67 • For protection against water and dust ingress

CABLES

- Signal Cable (6m)
- Power Cable (6m)

ARO • Anti-Rotate

Sold & Serviced By:





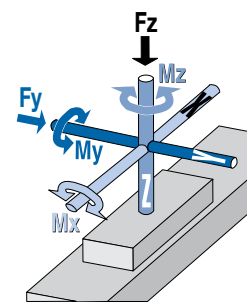

Toll Free Phone (877) SERV098
Toll Free Fax (877) SERV099
www.electromate.com
sales@electromate.com

MOMENT & LOAD CAPACITY



RODLESS SCREW DRIVE ACTUATORS

MODEL	SERIES	BENDING MOMENTS						LOAD				MAX. THRUST		MAX. SPEED		MAX. STROKE	
		Mx		My		Mz		Fy		Fz		lbf	N	in/sec	mm/sec	in	mm
		in-lbs	N-m	in-lbs	N-m	in-lbs	N-m	lb	N	lb	N						
 Standard	16	22	2.5	19	2.1	25	2.8	—	—	35	156	45	200	42	1,067	31	787
	25	60	6.8	110	12.4	34	3.8	—	—	70	311	170	756	60	1,524	134	3,404
	32	100	11.3	350	39.5	140	15.8	—	—	150	667	170	756	60	1,524	133	3,378
	40	275	31.1	600	67.8	220	24.9	—	—	225	1,001	800	3,559	60	1,524	131	3,327
	50	315	35.6	1,155	131	341	38.5	—	—	315	1,401	2,700	12,010	60	1,524	178	4,521
	63	585	66.1	2,340	264	520	58.8	—	—	520	2,313	4,300	19,127	50	1,270	125	3,175
 Auxiliary Carrier	16-DC	44	5.0	175	19.8	175	19.8	—	—	70	311	45	200	42	1,067	26	660
	25-DC	120	13.6	420	47.5	420	47.5	—	—	140	623	170	756	60	1,524	78	1,981
	32-DC	200	22.6	1,050	119	1,050	119	—	—	300	1,335	170	756	60	1,524	126	3,200
	40-DC	550	62.1	1,913	216	1,913	216	—	—	450	2,002	800	3,559	60	1,524	122	3,099
	50-DC	630	71.2	2,709	306	2,709	306	—	—	630	2,802	2,700	12,010	60	1,524	169	4,293
	63-DC	1,170	132	6,760	764	6,760	764	—	—	1,040	4,626	4,300	19,127	50	1,270	112	2,845

 Standard	16	39	4.4	339	38.3	339	38.3	217	965	217	965	45	200	42	1,067	31	787
	25	126	14.2	502	56.7	377	42.6	449	1,997	449	1,997	170	756	60	1,524	134	3,404
	32	226	25.5	1,344	152	1,344	152	569	2,531	569	2,531	170	756	60	1,524	133	3,378
	40	600	67.8	1,913	216	1,913	216	736	3,274	736	3,274	800	3,559	60	1,524	131	3,327
	50	811	92	3,483	394	3,483	394	1,014	4,511	1,014	4,511	2,700	12,010	60	1,524	178	4,521
	63	1,019	115	5,339	603	5,339	603	1,292	5,747	1,292	5,747	4,300	19,127	50	1,270	125	3,175
 Auxiliary Carrier	16-DC	79	8.9	620	70.1	620	70.1	434	1,931	434	1,931	45	200	42	1,067	26	660
	25-DC	252	28.5	1,613	182	1,613	182	898	3,995	898	3,995	170	756	60	1,524	78	1,981
	32-DC	457	51.6	2,202	249	2,202	249	1,138	5,062	1,138	5,062	170	756	60	1,524	126	3,200
	40-DC	1,200	136	3,601	407	3,601	407	1,472	6,548	1,472	6,548	800	3,559	60	1,524	122	3,099
	50-DC	1,623	183	4,966	561	4,966	561	2,028	9,021	2,028	9,021	2,700	12,010	60	1,524	169	4,293
	63-DC	2,038	230	9,508	1,074	9,508	1,074	2,583	11,490	2,583	11,490	4,300	19,127	50	1,270	112	2,845

The values listed are independent maximums for each force or moment load acting upon the actuator carrier. In applications where more than one force is acting upon the carrier, a loading combination factor must be used to determine if the forces are excessive. The Tolomatic sizing software properly applies the loading factor after entering the application's loads and forces. Contact your local distributor or Tolomatic for more information.

Sold & Serviced By:

 **ELECTROMATE**

Toll Free Phone (877) SERV098

Toll Free Fax (877) SERV099





www.electromate.com

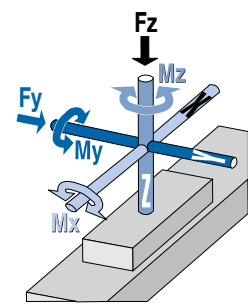

sales@electromate.com

MOMENT & LOAD CAPACITY



RODLESS SCREW DRIVE ACTUATORS

MODEL	SERIES	BENDING MOMENTS						LOAD				MAX. THRUST		MAX. SPEED		MAX. STROKE		
		Mx		My		Mz		Fy		Fz		lbf	N	in/sec	mm/sec	in	mm	
		in-lbs	N-m	in-lbs	N-m	in-lbs	N-m	lb	N	lb	N							
 Standard	B3S / M3S 10	250	28.2	269	30.4	156	17.6	341	1,517	591	2,629	170	756	60	1,524	136	3,454	
	15	859	97	1,033	117	596	67.3	840	3,737	1,454	6,468	800	3,559	60	1,524	133	3,378	
	20	1,662	188	1,472	166	850	96	1,159	5,156	2,008	8,932	2,700	12,010	60	1,524	179	4,547	
 Auxiliary Carrier	10-DC	500	56.5	2,825	319	1,630	184	682	3,034	1,182	5,258	170	756	60	1,524	131	3,327	
	15-DC	1,718	194	11,734	1,326	6,779	766	1,680	7,473	2,908	12,936	800	3,559	60	1,524	125	3,175	
	20-DC	3,324	376	16,265	1,838	9,388	1,061	2,318	10,311	4,016	17,864	2,700	12,010	60	1,524	171	4,343	
 Standard	B3SD / M3SD D10	657	74.2	312	35.3	538	60.8	1,182	5,258	682	3,034	170	756	60	1,524	136	3,454	
	D15	2,468	279	1,192	135	2,066	233	2,908	12,936	1,680	7,473	800	3,559	60	1,524	133	3,378	
	D20	4,527	512	1,700	192	2,944	333	4,016	17,864	2,318	10,311	2,700	12,010	60	1,524	179	4,547	
	 Auxiliary Carrier	D10-DC	1,314	149	3,328	376	5,768	652	2,364	10,516	1,364	6,067	170	756	60	1,524	131	3,327
		D15-DC	4,936	558	13,558	1,532	23,468	2,652	5,816	25,871	3,360	14,946	800	3,559	60	1,524	125	3,175
		D20-DC	9,054	1,023	18,776	2,122	32,530	3,676	8,032	35,728	4,636	20,622	2,700	12,010	60	1,524	171	4,343

 Standard	TKS 10	85	9.6	234	26.4	234	26.4	100	445	100	445	230	1,023	30	762	96	2,438
	25	721	82	1,014	115	915	103	250	1,112	250	1,112	1,590	7,073	30	762	96	2,438
	50	971	110	1,442	163	1,301	147	500	2,224	500	2,224	2,830	12,589	60	1,524	96	2,438
	75	1,151	130	1,477	167	1,332	151	750	3,336	750	3,336	3,260	14,501	40	1,016	96	2,438
 Auxiliary Carrier	10-DC	170	19.2	563	63.6	563	63.6	200	890	200	890	230	1,023	30	762	88	2,235
	25-DC	1,442	163	1,733	196	1,733	196	500	2,224	500	2,224	1,590	7,073	30	762	88	2,235
	50-DC	1,942	219	3,810	431	3,810	431	1,000	4,448	1,000	4,448	2,830	12,589	60	1,524	88	2,235
	75-DC	2,302	260	3,875	438	3,875	438	1,500	6,672	1,500	6,672	3,260	14,501	40	1,016	88	2,235

The values listed are independent maximums for each force or moment load acting upon the actuator carrier.

In applications where more than one force is acting upon the carrier, a loading combination factor must be used to determine if the forces are excessive. The Tolomatic sizing software properly applies the loading factor after entering the application's loads and forces. Contact your local distributor or Tolomatic for more information.

Sold & Serviced By:

 **ELECTROMATE**

Toll Free Phone (877) SERV098

Toll Free Fax (877) SERV099

www.electromate.com



sales@electromate.com

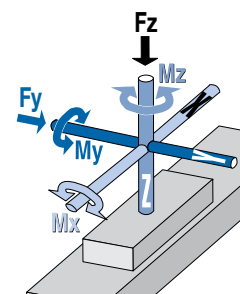



MOMENT & LOAD CAPACITY



RODLESS BELT DRIVE ACTUATORS

MODEL	SERIES	BENDING MOMENTS						LOAD				MAX. THRUST		MAX. SPEED		MAX. STROKE	
		Mx		My		Mz		Fy		Fz							
		in-lbs	N-m	in-lbs	N-m	in-lbs	N-m	lb	N	lb	N	lbf	N	in/sec	mm/sec	in	mm
	16	—	—	—	—	—	—	—	—	—	—	38	169	200	5,080	230	5,842
	25	—	—	—	—	—	—	—	—	—	—	151	672	200	5,080	200	5,080
	32	—	—	—	—	—	—	—	—	—	—	209	930	200	5,080	200	5,080
	40	—	—	—	—	—	—	—	—	—	—	250	1,112	200	5,080	200	5,080
	50	—	—	—	—	—	—	—	—	—	—	325	1,446	200	5,080	200	5,080
	63	—	—	—	—	—	—	—	—	—	—	418	1,859	200	5,080	100	2,540

	16	39	4.4	339	38.3	339	38.3	217	965	217	965	38	169	150	3,810	230	5,842
	25	126	14.2	502	56.7	377	42.6	449	1,997	449	1,997	151	672	150	3,810	200	5,080
	32	226	25.5	1,344	152	1,344	152	569	2,531	569	2,531	209	930	150	3,810	200	5,080
	40	600	67.8	1,913	216	1,913	216	736	3,274	736	3,274	250	1,112	150	3,810	200	5,080
	50	811	92	3,483	394	3,483	394	1,014	4,511	1,014	4,511	325	1,446	150	3,810	200	5,080
	63	1,019	115	5,339	603	5,339	603	1,292	5,747	1,292	5,747	418	1,859	150	3,810	100	2,540
	16-DC	79	8.9	620	70.1	620	70.1	434	1,931	434	1,931	38	169	150	3,810	225	5,715
	25-DC	252	28.5	1,613	182	1,613	182	898	3,995	898	3,995	151	672	150	3,810	194	4,927
	32-DC	457	51.6	2,202	249	2,202	249	1,138	5,062	1,138	5,062	209	930	150	3,810	193	4,902
	40-DC	1,200	136	3,601	407	3,601	407	1,472	6,548	1,472	6,548	250	1,112	150	3,810	191	4,851
	50-DC	1,623	183	4,966	561	4,966	561	2,028	9,021	2,028	9,021	325	1,446	150	3,810	191	4,851
	63-DC	2,038	230	9,508	1,074	9,508	1,074	2,583	11,490	2,583	11,490	418	1,859	150	3,810	87	2,209

	10	250	28.2	269	30.4	156	17.6	341	1,517	591	2,629	150	667	200	5,080	292	7,417
	15	859	97	1,033	117	596	67.3	840	3,737	1,454	6,468	250	1,112	200	5,080	204	5,182
	20	1,662	188	1,472	166	850	96	1,159	5,156	2,008	8,932	325	1,446	200	5,080	156	3,962
	10-DC	500	56.5	2,825	319	1,630	184	682	3,034	1,182	5,258	150	667	200	5,080	287	7,290
	15-DC	1,718	194	11,734	1,326	6,779	766	1,680	7,473	2,908	12,936	250	1,112	200	5,080	196	4,978
	20-DC	3,324	376	16,265	1,838	9,388	1,061	2,318	10,311	4,016	17,864	325	1,446	200	5,080	148	3,759
	D10	657	74.2	312	35.3	538	60.8	1,182	5,258	682	3,034	150	667	200	5,080	292	7,417
	D15	2,468	279	1,192	135	2,066	233	2,908	12,936	1,680	7,473	250	1,112	200	5,080	204	5,182
	D20	4,527	512	1,700	192	2,944	333	4,016	17,864	2,318	10,311	325	1,446	200	5,080	156	3,962
	D10-DC	1,314	149	3,328	376	5,768	652	2,364	10,516	1,364	6,067	150	667	200	5,080	287	7,290
	D15-DC	4,936	558	13,558	1,532	23,468	2,652	5,816	25,871	3,360	14,946	250	1,112	200	5,080	196	4,978
	D20-DC	9,054	1,023	18,776	2,122	32,530	3,676	8,032	35,728	4,636	20,622	325	1,446	200	5,080	148	3,759

The values listed are independent maximums for each force or moment load acting upon the actuator carrier.

In applications where more than one force is acting upon the carrier, a loading combination factor must be used to determine if the forces are excessive. The Tolomatic sizing software properly applies the loading factor after entering the application's loads and forces. Contact your local distributor or Tolomatic for more information.

Sold & Serviced By:

 **ELECTROMATE**

Toll Free Phone (877) SERV098

Toll Free Fax (877) SERV099



www.electromate.com

sales@electromate.com

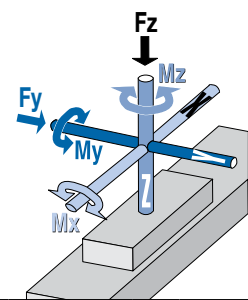
MOMENT & LOAD CAPACITY





RODLESS BELT DRIVE ACTUATORS

MODEL	SERIES	BENDING MOMENTS						LOAD				MAX. THRUST		MAX. SPEED		MAX. STROKE	
		Mx		My		Mz		Fy		Fz		lbf	N	in/sec	mm/sec	in	mm
		in-lbs	N-m	in-lbs	N-m	in-lbs	N-m	lb	N	lb	N						
 Standard	10	85	9.6	234	26.4	234	26.4	100	445	100	445	75	334	100	2,540	96	2,438
	15	721	82	1,014	115	915	103	250	1,112	250	1,112	120	534	100	2,540	96	2,438
	50	971	110	1,442	163	1,301	147	500	2,224	500	2,224	195	867	100	2,540	96	2,438
	75	1,151	130	1,477	167	1,332	151	750	3,336	750	3,336	245	1,090	100	2,540	96	2,438
 Auxiliary Carrier	10-DC	170	19.2	563	63.6	563	63.6	200	890	200	890	75	334	100	2,540	88	2,235
	25-DC	1,442	163	1,733	196	1,733	196	500	2,224	500	2,224	120	534	100	2,540	88	2,235
	50-DC	1,942	219	3,810	431	3,810	431	1,000	4,448	1,000	4,448	195	867	100	2,540	88	2,235
	75-DC	2,302	260	3,875	438	3,875	438	1,500	6,672	1,500	6,672	245	1,090	100	2,540	88	2,235

ROD STYLE SCREW DRIVE ACTUATORS

MODEL	SERIES	MAX. THRUST		MAX. SPEED		MAX. STROKE	
		lbf	N	in/sec	mm/sec	in	mm
 ERD	06	20	89	40	1,016	8	203
	10	100	445	40	1,016	10	254
	15	200	890	40	1,016	24	610
	20	500	2,224	20	508	24	610
	25	3,300	14,679	40	1,016	36	914
	30	4,500	20,017	40	1,016	36	914

 ICR	20	720	3,203	24	609	24	609
--	----	-----	-------	----	-----	----	-----

 RSA	12	130	578	123	3,124	18	457
	16	471	2,095	123	3,124	18	457
	24	1,700	7,562	29	737	24	610
	32	3,300	14,679	50	1,270	36	914
	50	4,109	18,278	50	1,270	48	1,219
	64	7,350	32,695	58	1,473	60	1,524

 GSA	12	130	578	123	3,124	18	457
	16	471	2,095	123	3,124	24	609
	24	850	3,781	29	737	30	762
	32	2,670	11,877	50	1,270	36	914

 IMA	22	325	1,446	28	711	18	457
	33	1,700	7,562	48	1,219	18	457
	44	3,300	14,679	52.5	1,334	18	457
	55	6,875	30,594	31.4	787	18	457

The values listed are independent maximums for each force or moment load acting upon the actuator carrier.

In applications where more than one force is acting upon the carrier, a loading combination factor must be used to determine if the forces are excessive. The Tolomatic sizing software properly applies the loading factor after entering the application's loads and forces. Contact your local distributor or Tolomatic for more information.

Sold & Serviced By:

 **ELECTROMATE**

Toll Free Phone (877) SERV098

Toll Free Fax (877) SERV099

www.electromate.com

sales@electromate.com